

# P 524X

Product no: 970 60 15-01

## Husqvarna P 524X

Husqvarna P 524X is a front-mounted petrol ride-on lawn mower, built for commercial use. Compact and versatile with articulated steering, All-Wheel Drive and a powerful engine from Kawasaki. An electric attachment lift enables efficient and comfortable work. Intended for facility management companies, sports clubs and for contractors who want a manoeuvrable ride-on solution for year-round duties in complex areas. Delivered deck-less, can be equipped with 112 and 122 cm Combi cutting decks.

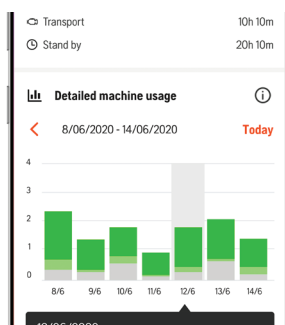

### Integrated connectivity

The model has a built-in connectivity module which easily can be connected with Husqvarna Fleet Services™. Allowing you to see the single product as well as your entire fleet of connected product's last known location, its usage stats and service history – and much more. This also facilitates updates of the product's firmware, so that it's always compatible with the latest functions in Husqvarna Fleet Services™.



### All-Wheel Drive (AWD)

The machine's low centre of gravity in combination with the high-performing AWD-system gives excellent slope and hillside stability.

### Articulated steering

The unique articulated steering system allows the rear pair of wheels to swing in underneath the machine. The result is superior manoeuvrability with a minimum turning radius at full lock.



### Durable ladder frame

Heavy-duty steel ladder frame with reinforcements combined with an open design for excellent serviceability.

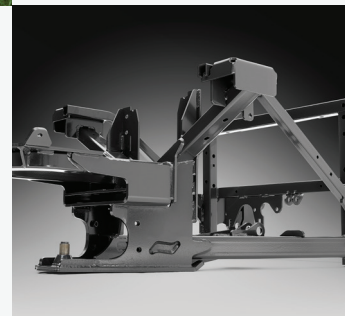

## FEATURES

- Min. clearance circle by articulated steering
- Excellent hillside driving performance
- The model has a built-in connectivity module which easily can be connected with Husqvarna Fleet Services™.
- Heavy-duty, durable steel ladder frame
- Hydraulic power steering for increased comfort
- Equipped with a Kawasaki V-twin engine with overhead 90° valves and a high performance lubrication system.
- Accessories for versatile year/round usage
- Easy tool exchange by unique quick coupling
- Front-mounted cutting deck for precise trimming
- Unbeatable mowing accessibility
- Ergonomic operator's interface
- Operator environment design around the user. The control panel is raised with all controls ergonomically positioned for easy access.
- Equally sized wheels for a comfortable ride
- Dual LED lights for enlarged lighted area and safer operation in darker conditions.
- Parking brake with electric engagement enables safe handling.
- Equipped with a Roll Over Protective Structure (ROPS). Ensures a safe ride for the operator.
- Electrical front- and rear outlets for power and control of attachments (available as separate accessory).
- Commercial graded transmission
- Durable cast iron rear wagon
- The X series facelift features several improvements, like an upgraded PTO belt system, a hardwearing foot plate made of corrugated steel sheet and a more compliant and robust pedal system.
- Greasable mandrels for easy maintenance
- Service position for easy deck maintenance.
- Designed to deliver a cutting result in top-class, offering two cutting methods in one deck; mulching or rear discharge (mulch plug removed).

### Technical Specifications

BATTERY	
Battery capacity	24 Ah
Battery manufacturer	Global
Battery type	Lead-Acid
Battery voltage	12 V
Quantity of batteries/battery pack	1 pcs
CAPACITY	
Net power at preset rpm	3000 rpm
Net power at preset rpm Energy	13.9 kW
Power output	13.9 kW
Speed forward max	13 km/h
Speed reverse max	9 km/h
DIMENSIONS	
Article gross weight	516000 g
Article net weight	433000 g
Base machine. height	122 cm
Base machine. length	206 cm
Base machine. width	98 cm
Gross weight towed	200 kg
Ground clearance	130 mm
Seat back height	High
Tyre manufacturer	Kenda
Weight	433 kg
Weight (excl. cutting equipment)	433 kg
Wheelbase	100 cm
ENGINE	
Cylinder displacement	726 cm <sup>3</sup>
Cylinders	2
Engine cooling	Air
Engine name	FX Series V-Twin
Motor/engine manufacturer	Kawasaki
Motor/engine model	FX691V
Transmission type	Hydrostatic
EQUIPMENT	
12V outlet	Yes
Air filter type	Heavy-Duty Canister Style
Blade engagement	Electric clutch
Cargo holder	Yes
Cup holder	Yes
Drive method	Dual pedal-operation
Drive system	All-wheel drive
Foldable seat	Yes
Headlights	Yes
Hour meter type	Digital
Hydraulic equipment lift	Yes
Optional cutting decks	Combi 112, Combi 122
Parking brake. type	Disc
Pivoting rear axle	Yes

<b>Technical Specifications</b>	
Power steering	Yes
Seat suspension	Yes
Seat type	Professional
Service position	Yes
Wheelbase	100 cm
<b>LUBRICANTS</b>	
Fuel consumption	334 g/kWh
Fuel tank location	Side (Single)
Lubricant type (Engine)	SAE 10 W-40
Oil cooler	Yes
Oil filter	Yes
Power/fuel type	Petrol
Engine cooling	Air
<b>MATERIALS</b>	
Master pack: Paper + Cardboard	0 g
Metal total	0 g
Paper + Cardboard total	0 g
PE total	0 g
PET total	0 g
Plastic foil	0 g
Plastic rigid	0 g
Plastic total	0 g
PS/EPS/HIPS total	0 g
Seat material	Vinyl
<b>PACKAGING</b>	
Packaging height	1470 mm
Packaging length	2250 mm
Packaging width	1250 mm
Packaging volume	4134 dm <sup>3</sup>
Quantity in Master pack	1
<b>EMISSION DATA EU</b>	
Exhaust emissions (CO2 EU V)	792 g/kWh
<b>SOUND AND NOISE</b>	
Sound power level, guaranteed (LWA)	105 dB(A)
Sound power level, measured	104 dB(A)
Sound pressure level at operators ear	90 dB(A)
<b>VIBRATIONS</b>	
Vibration level seat	0.5 m/s <sup>2</sup>
Vibration level steering wheel	2.5 m/s <sup>2</sup>

Husqvarna is a registered trademark. Copyright © 2023 HUSQVARNA. All rights reserved.

Husqvarna New Zealand Ltd  
P O Box 76 437, Manukau City 2241  
Customer Service Phone: 09 920 2410 Email: customer.service@husqvarna.co.nz

[husqvarna.com](https://www.husqvarna.com)