

Contents

Select Language ▼

Powered by **Translate**

Tip-Out Glass Windshield Kit

P/N 2889020

Before You Begin

Read these instructions and check to be sure all parts and tools are accounted for. Please retain these installation instructions for future reference and parts ordering information.

Application

Verify accessory fitment at www.polaris.com.

Kit Contents

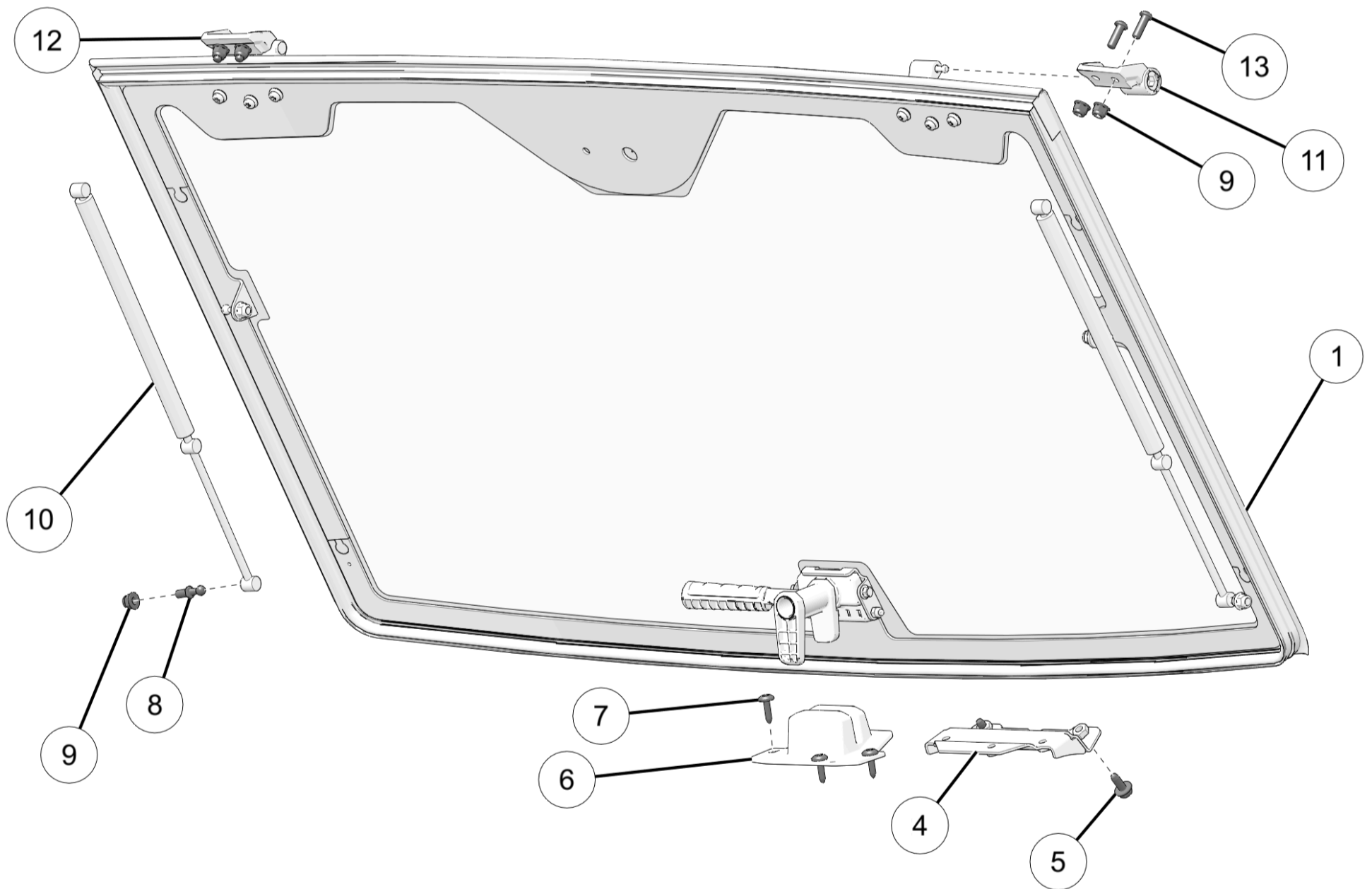

Ref	Qty	Part Description	P/N Available Separately	Available Service Kit
1	1	Windshield Assembly - Glass, Tip-out	2638581	n/a
2	1	Not Used	n/a	n/a
3	1	Not Used	n/a	n/a
4	1	Bracket - Backer, Handle Base	5265266	n/a
5	2	Screw - Hex Flange, (M8 x 1.25 x 20 mm)	7518555	n/a
6	1	Base, Handle	n/a	2207450

Ref	Qty	Part Description	P/N Available Separately	Available Service Kit
7	3	Screw – Torx® Truss Head, (M6 x 1.0 x 25 mm)	7519650	n/a
8	2	Fitting – Ball End, (M8 x 1.25 mm)	n/a	2207158
9	4 2	Nut – Hex Flange, (M8 x 1.25 mm) Nut – Hex Flange, (M8 x 1.25 mm)	n/a n/a	2207159 2207158
10	2	Shock – Gas, Tip-out	n/a	2207158
11	1	Mount – Windshield, Glass, Tip-out, Right	5633879	n/a
12	1	Mount – Windshield, Glass, Tip-out, Left	5633878	n/a
13	4	Screw – Torx® Button Head, (M8 x 1.25 x 25 mm)	n/a	2207159
14	1	Windshield Seal Kit (not shown)	n/a	2209472

Tools Required

- Safety Glasses
- Drill
- Drill Bit:
 - 3/8 in (9 mm)
- Pliers, Push Pin Rivet
- Screwdriver, Slotted
- Screwdriver Set, Torx®
- Socket Set, Metric
- Wrench Set, Metric

Important

Your Tip-Out Glass Windshield Kit is exclusively designed for your vehicle. Please read the installation instructions thoroughly before beginning. Installation is easier if the vehicle is clean and free of debris. For your safety, and to ensure a satisfactory installation, perform all installation steps correctly in the sequence shown.

Installation Instructions

Vehicle Preparation

General

1. Park vehicle on a flat surface.
2. Shift vehicle into PARK.
3. Turn key to OFF position and remove key.

Cup Holder Removal (if equipped)

1. Remove two push-pin rivets from cup holder.

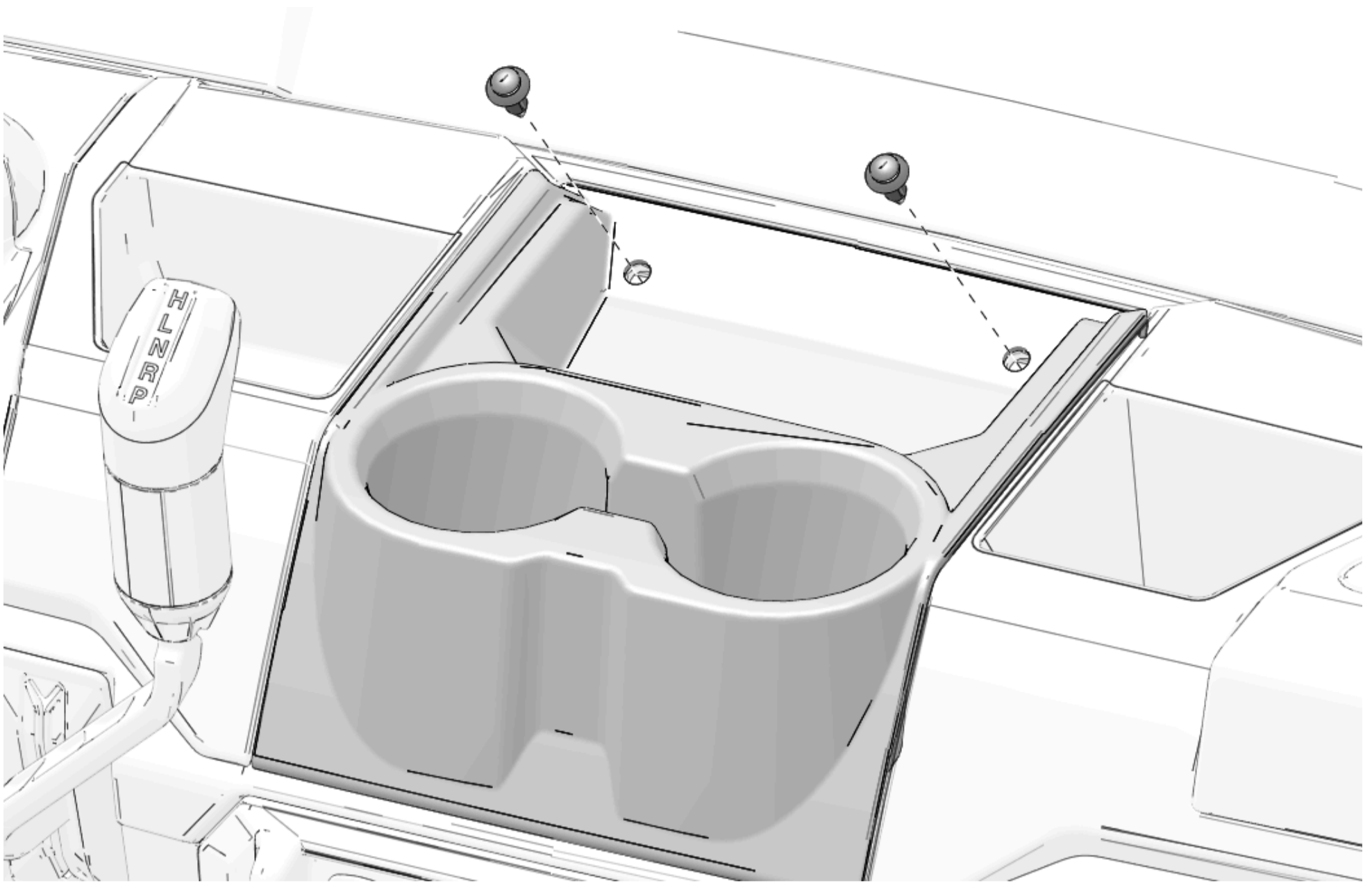

2. Remove cup holder from dashboard.

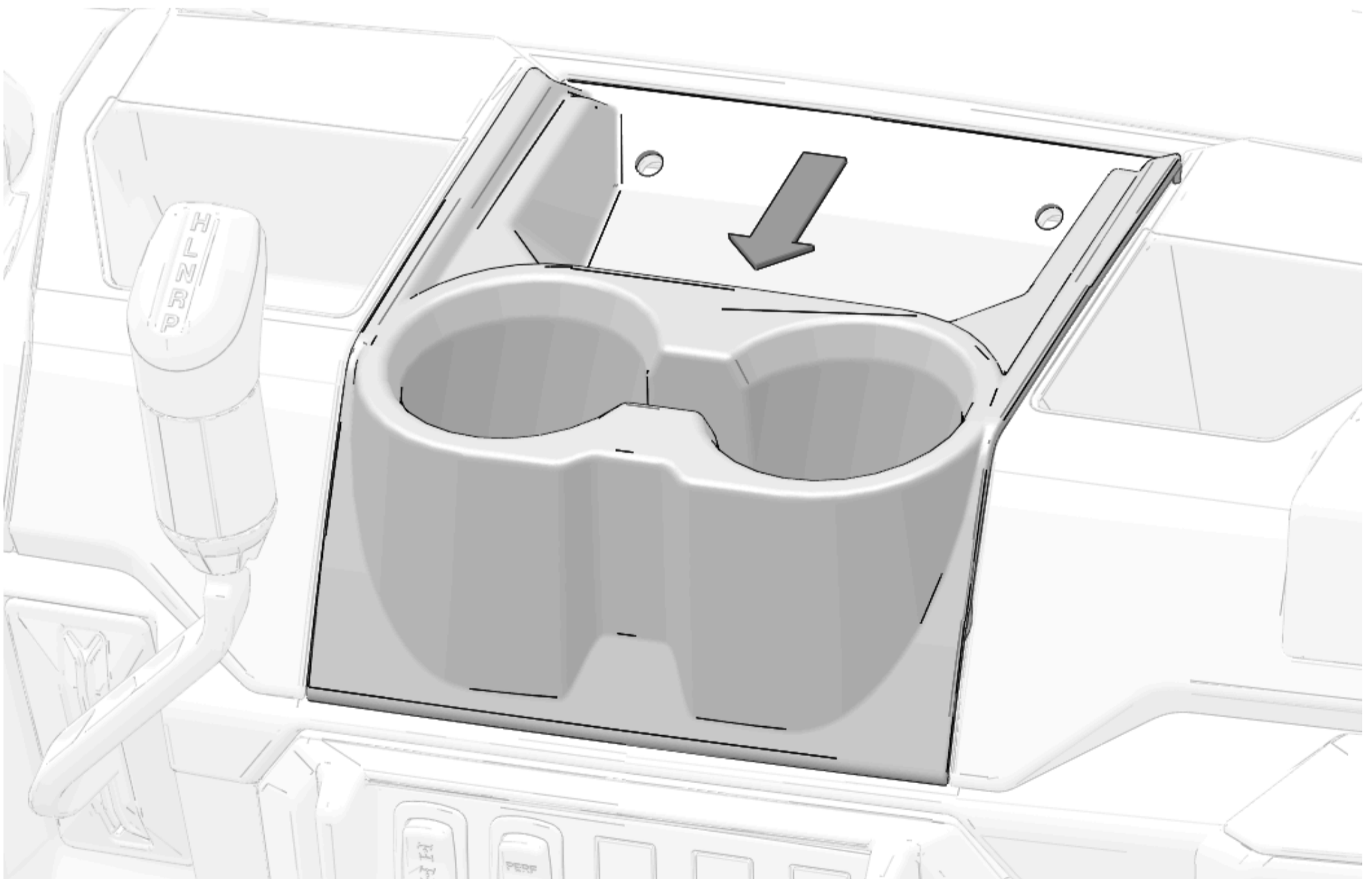

Prepare Cup Holder

1. Align handle base (6) with edge of angle on cupholder, as shown.

NOTICE

Match angle on cup holder with angle on windshield bracket.

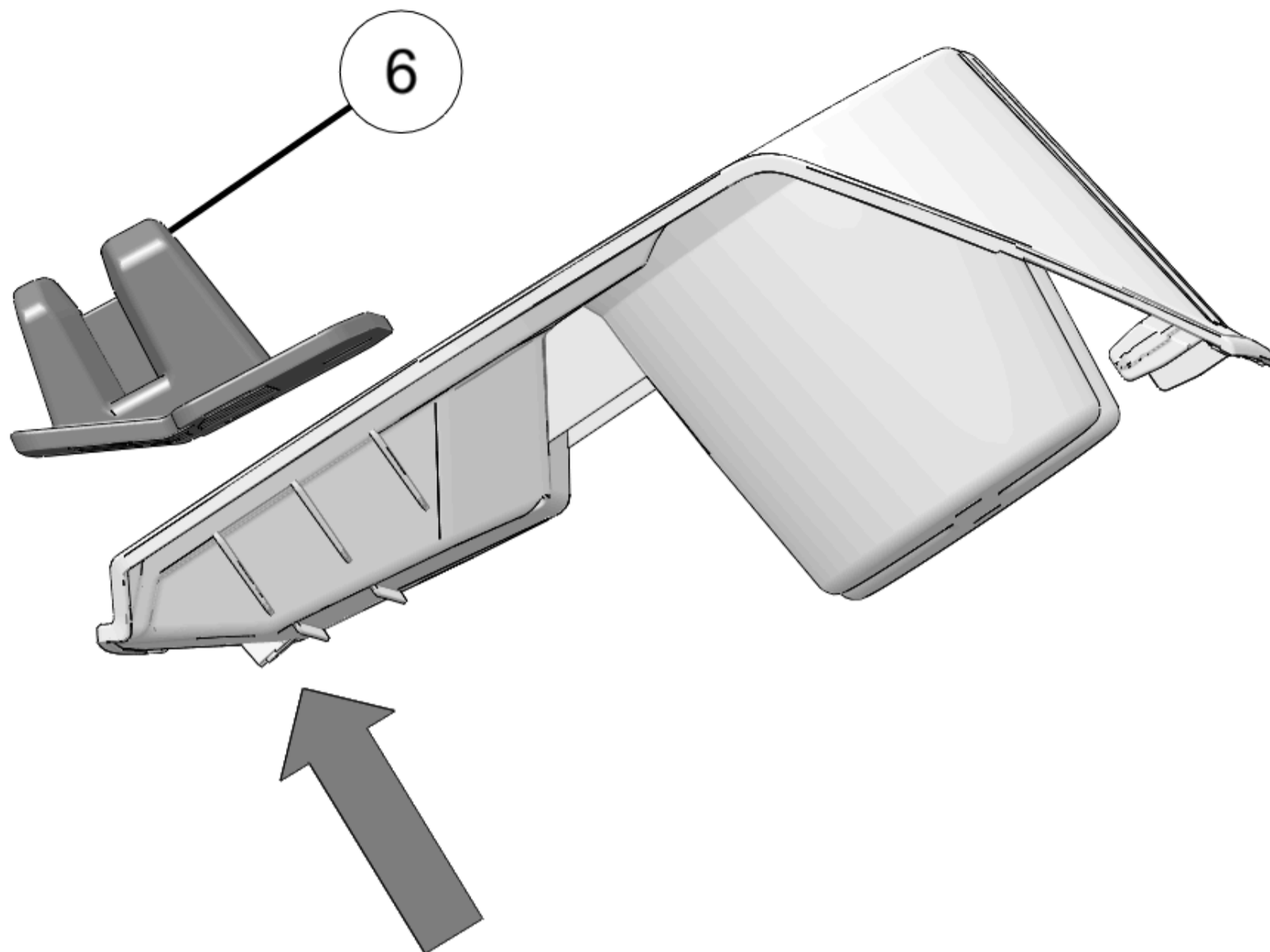

2. Use handle base ⑥ as a template to mark three holes on cup holder.

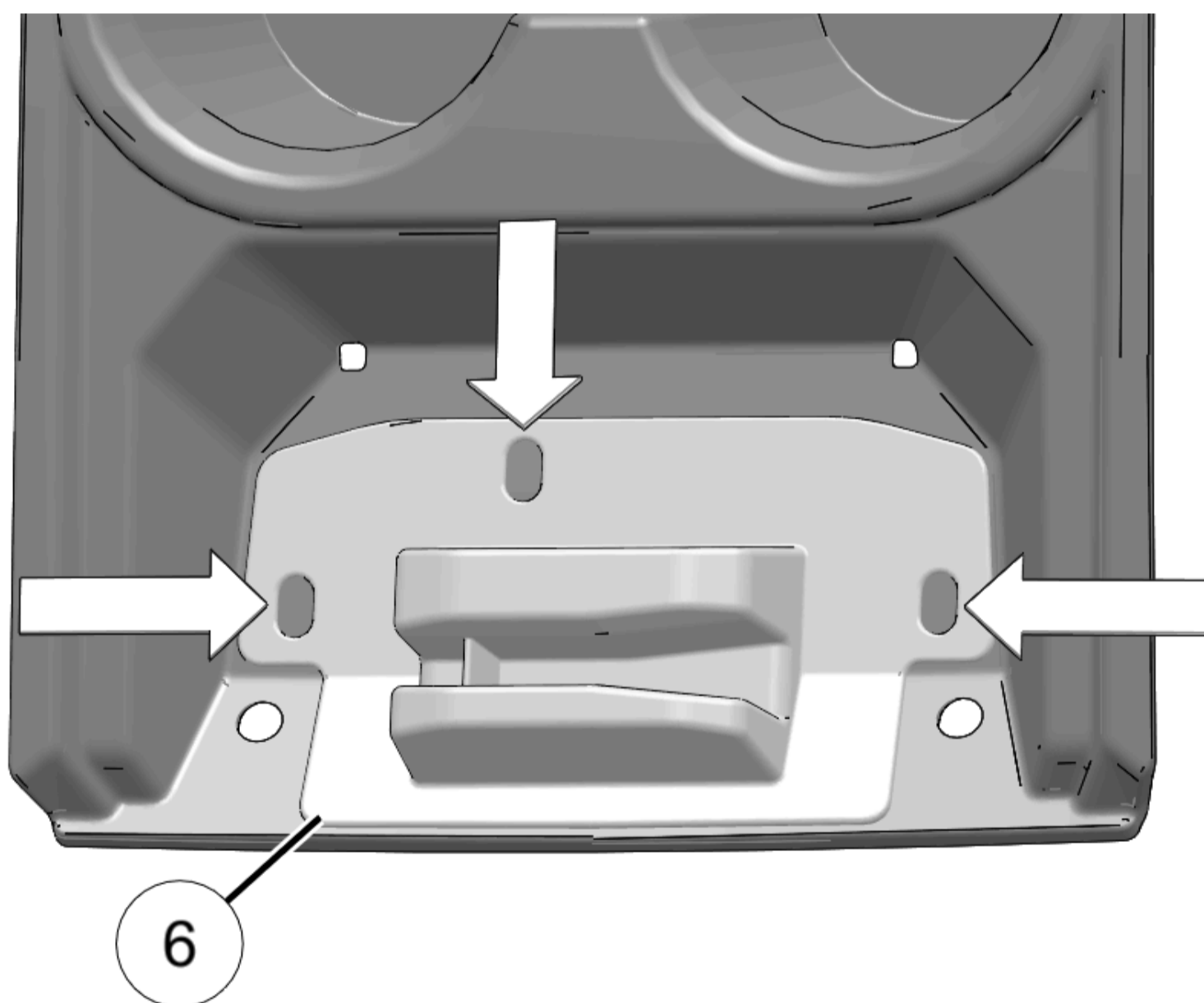

3. Put cup holder in vehicle.

4. Drill three holes.

IMPORTANT

Control drill depth to prevent damage to underlying structure or components.

MEASUREMENT

Drill Bit Size:

3/8 in (9 mm)

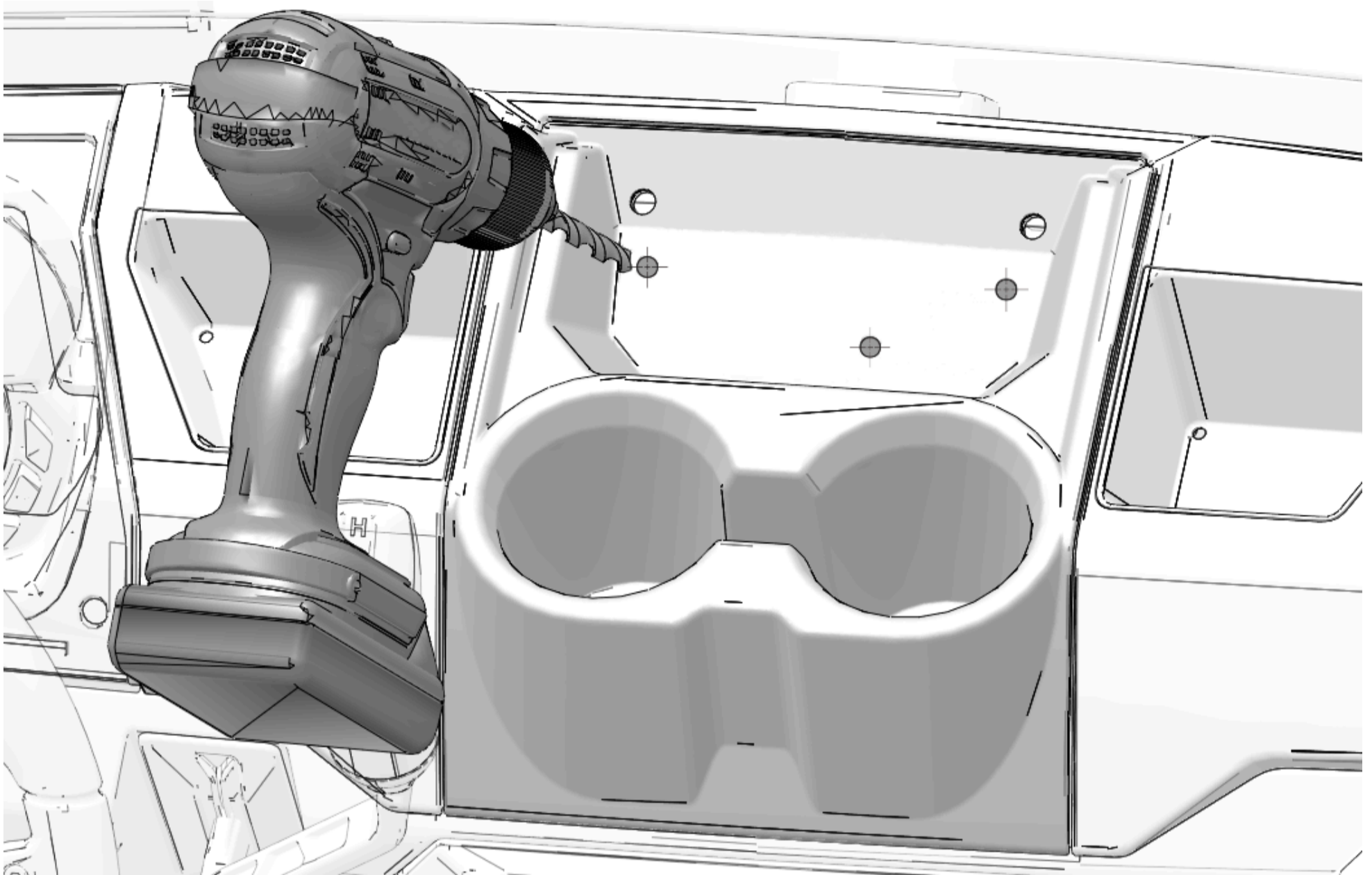

5. Remove cup holder.

Accessory Installation

Windshield Seal Installation

1. Install windshield seal kit (14).

NOTICE

Follow instructions included with seal kit for correct installation.

Backer Bracket Installation

1. Put backer bracket (4) through cup holder opening.

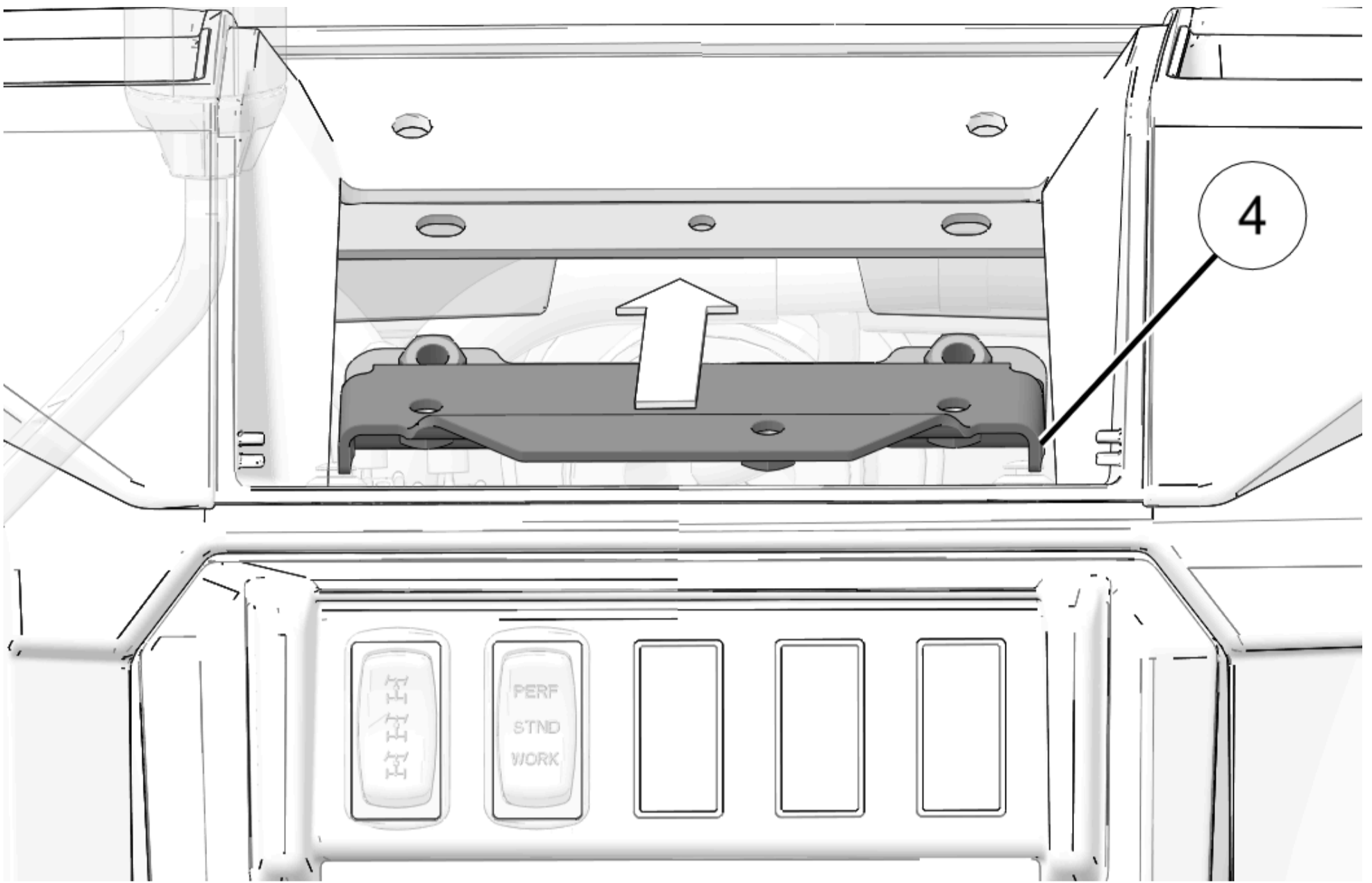

2. Install backer bracket (4) to upper chassis bar with two screws (5).

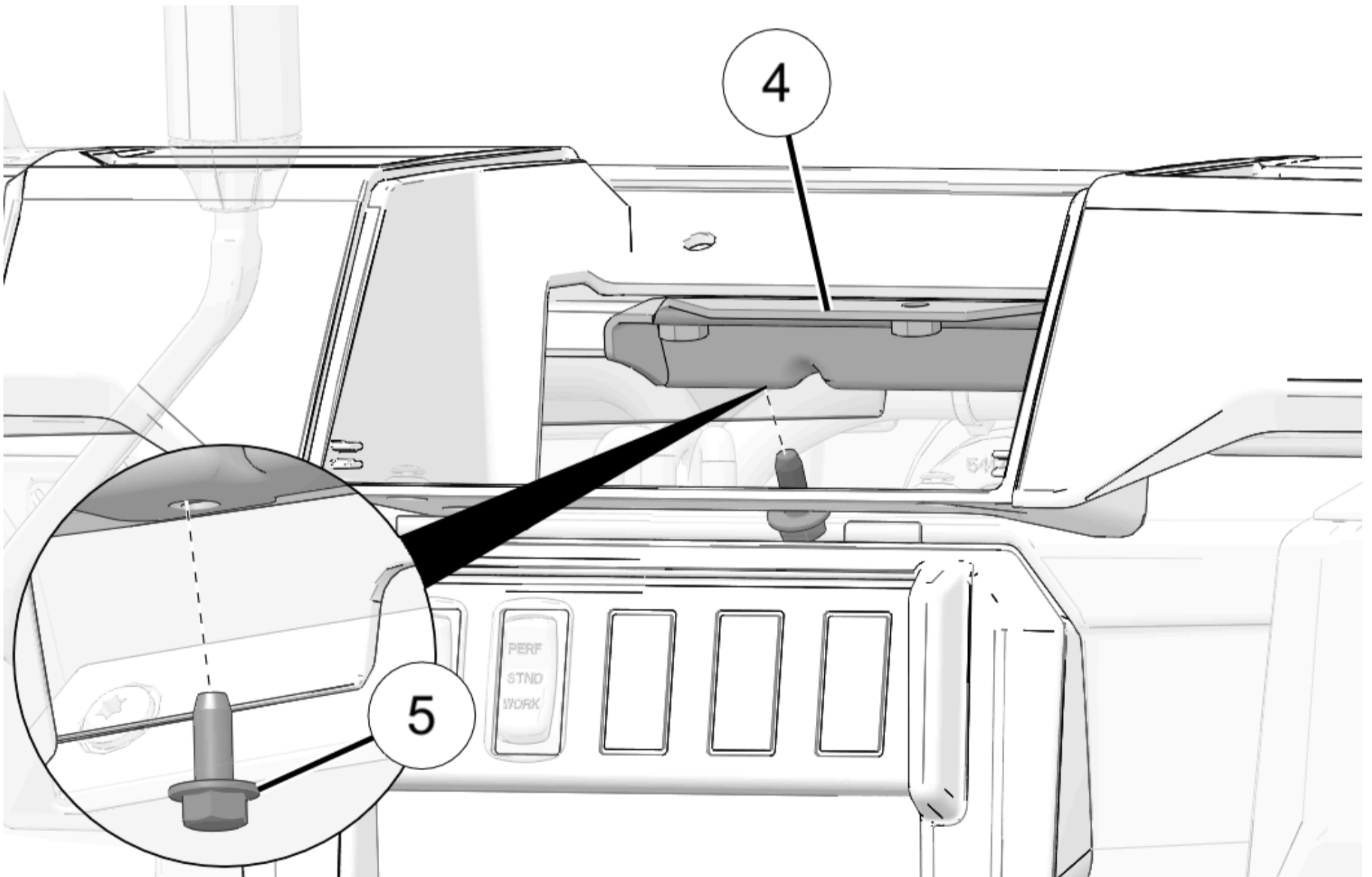

NOTICE

Dash has been hidden to show backer bracket installation location on chassis bar.

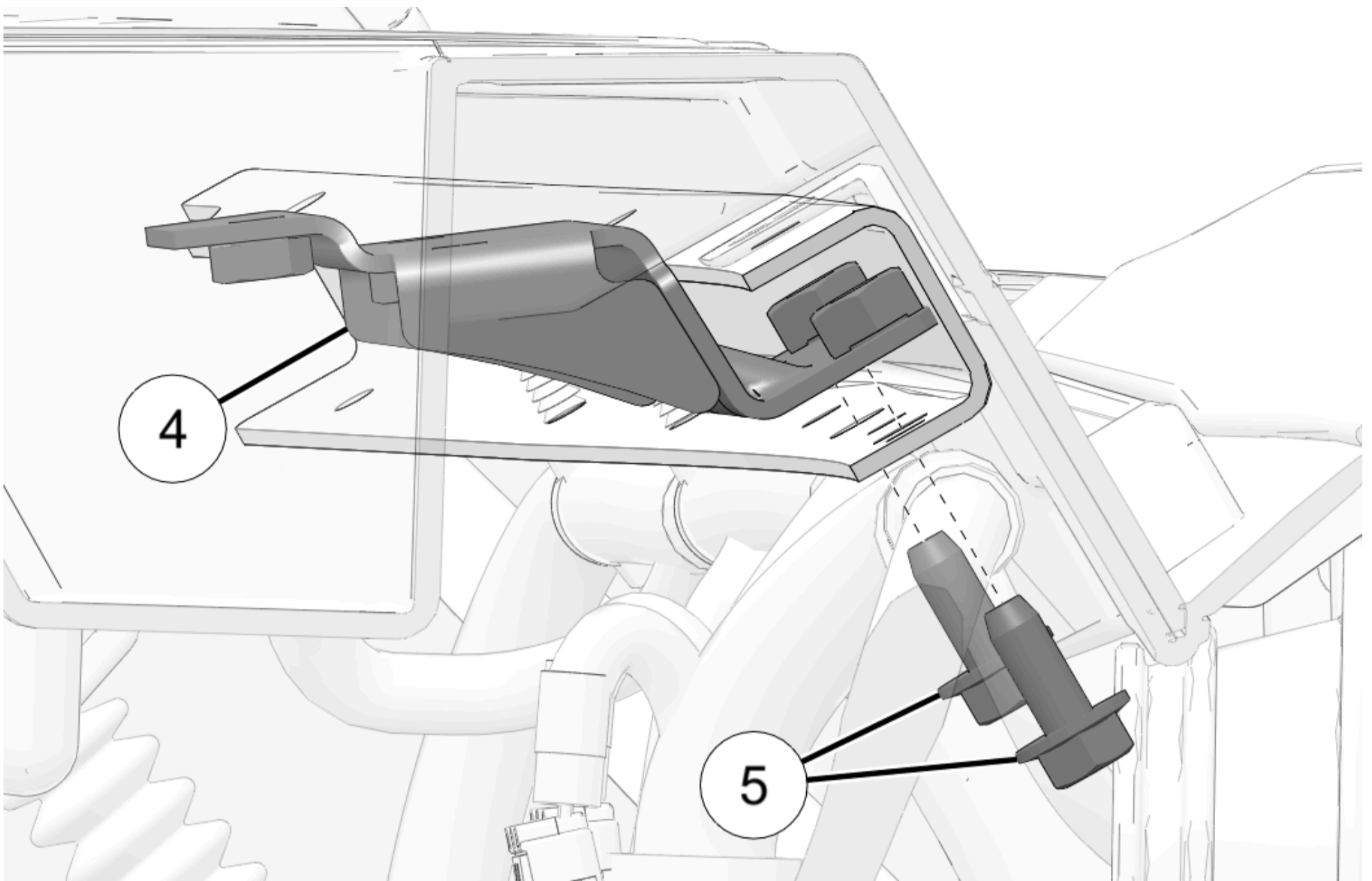

3. Torque screws to specification.

TORQUE

Backer Bracket Screws (5):

20 ft-lbs (27 N·m)

Cup Holder Installation

1. Put cup holder in vehicle.

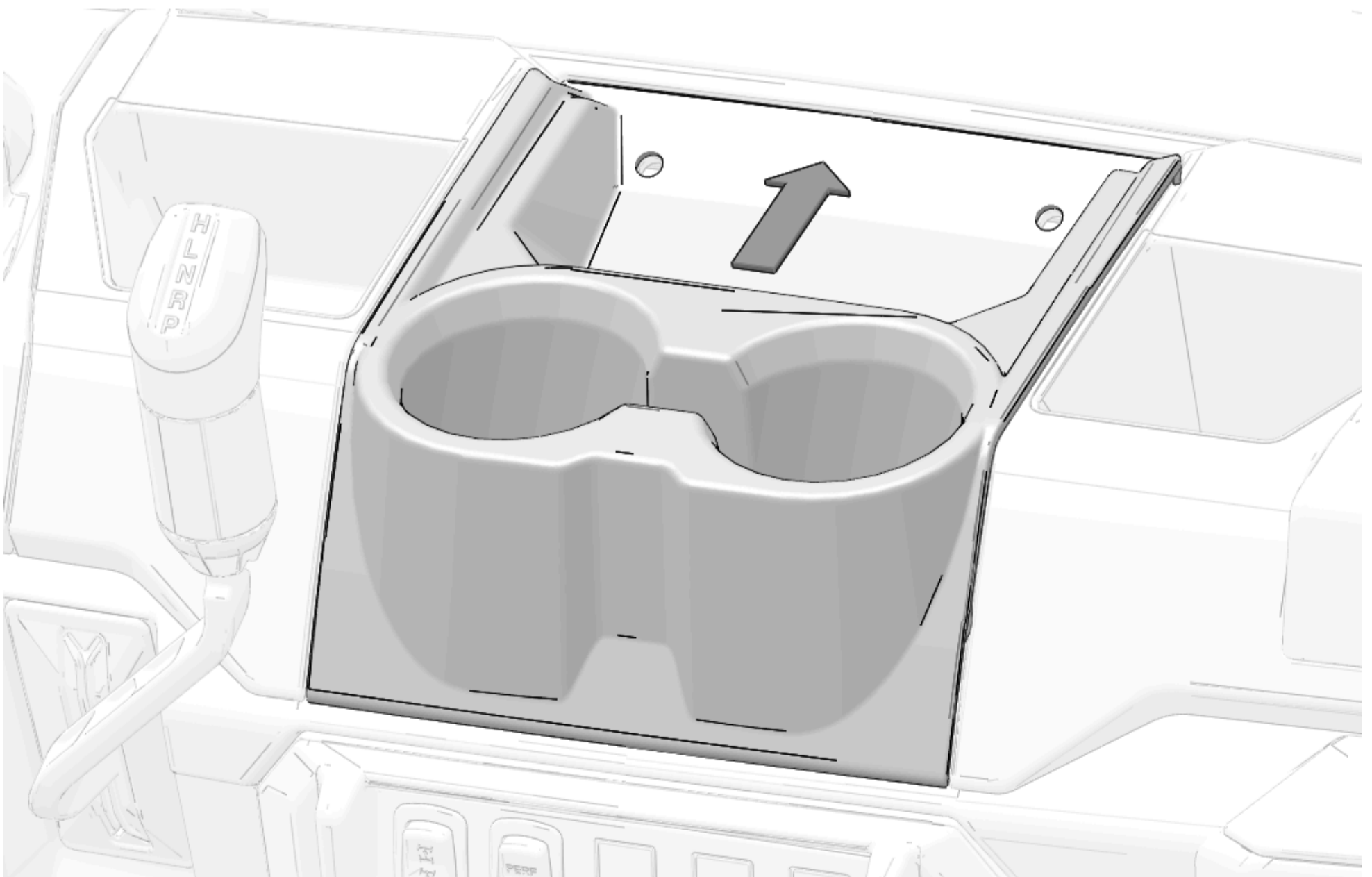

2. Install cup holder with two retained push-pin rivets.

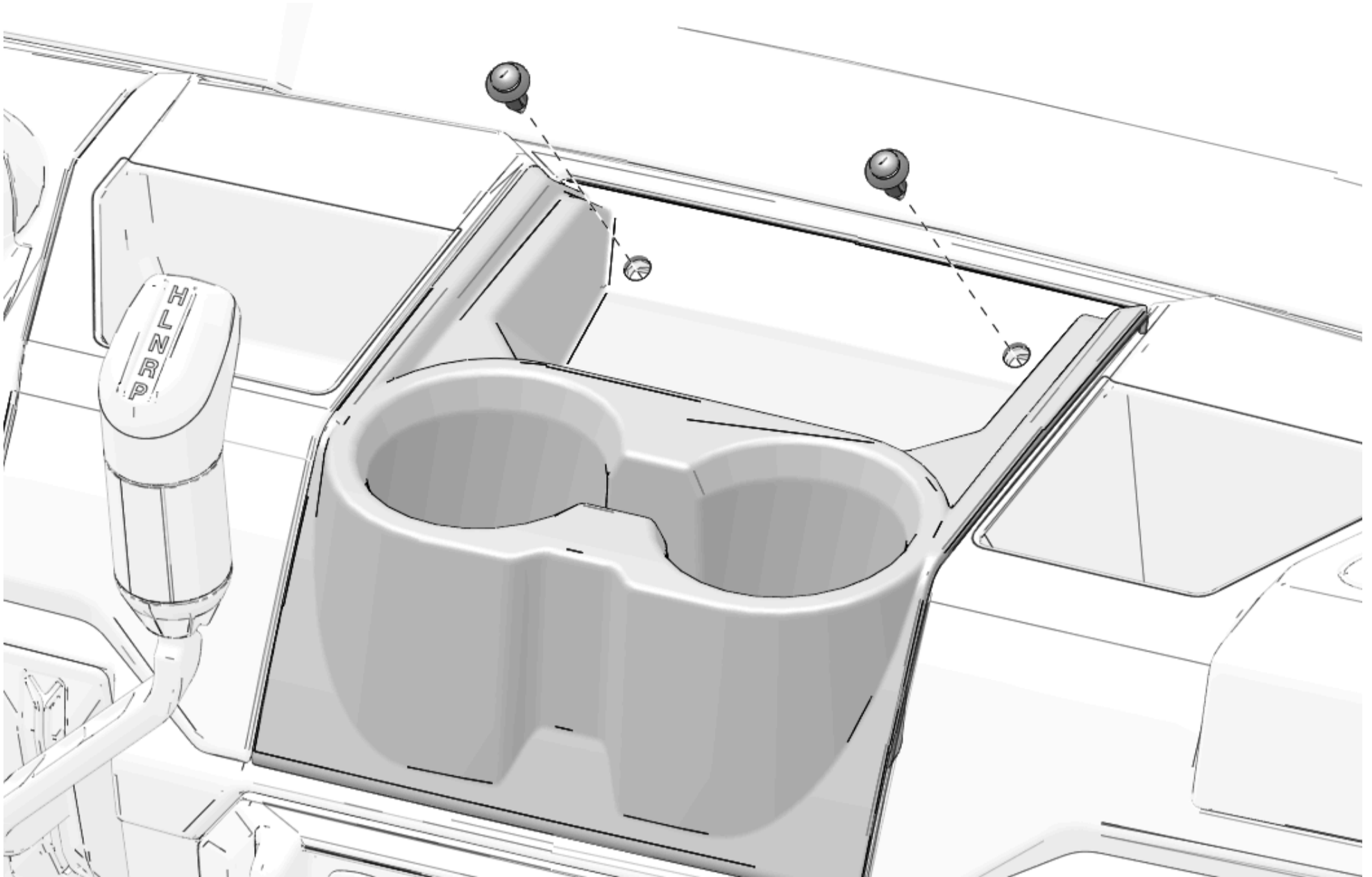

Handle Base Installation

1. Align holes on handle base ⑥ with drilled holes in cup holder.

NOTICE

If necessary, enlarge pre-drilled cup holder holes so they align with the holes on the handle base.

2. Install handle base ⑥ to cup holder with three screws ⑦.

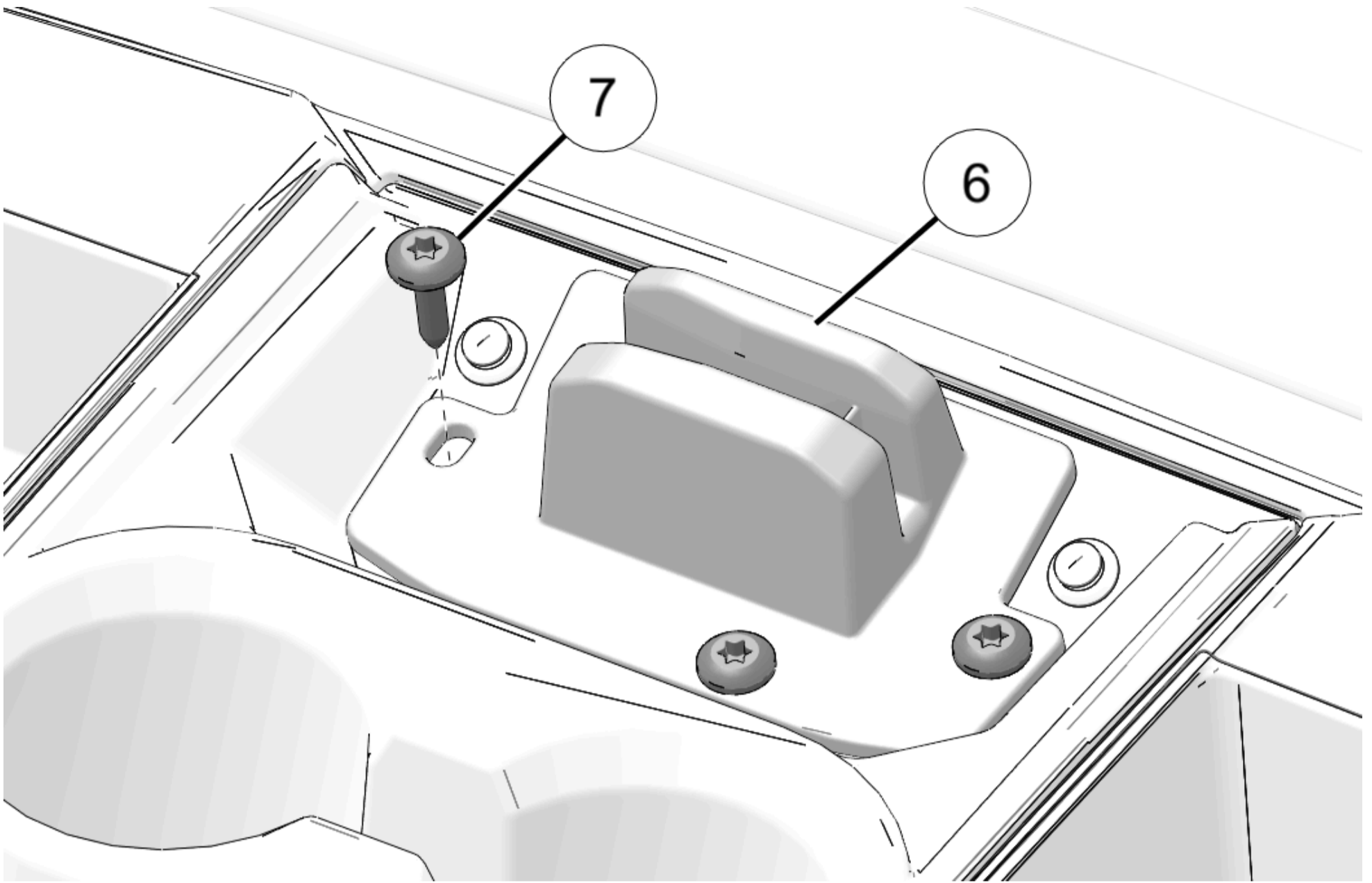

3. Torque screws to specification.

TORQUE

Handle Base Screws (7):

88 in-lbs (10 N·m)

Windshield Mount Installation

⚠ CAUTION

It is recommended that two people install the windshield onto the vehicle. The windshield is large and may be difficult for one person to easily handle. Failure to have two people install the windshield onto the vehicle could result in possible personal injury.

1. Loosely install left side windshield mount (12) to upper ROPS bar with two screws (13) and two nuts (9).

Do not torque nuts at this time.

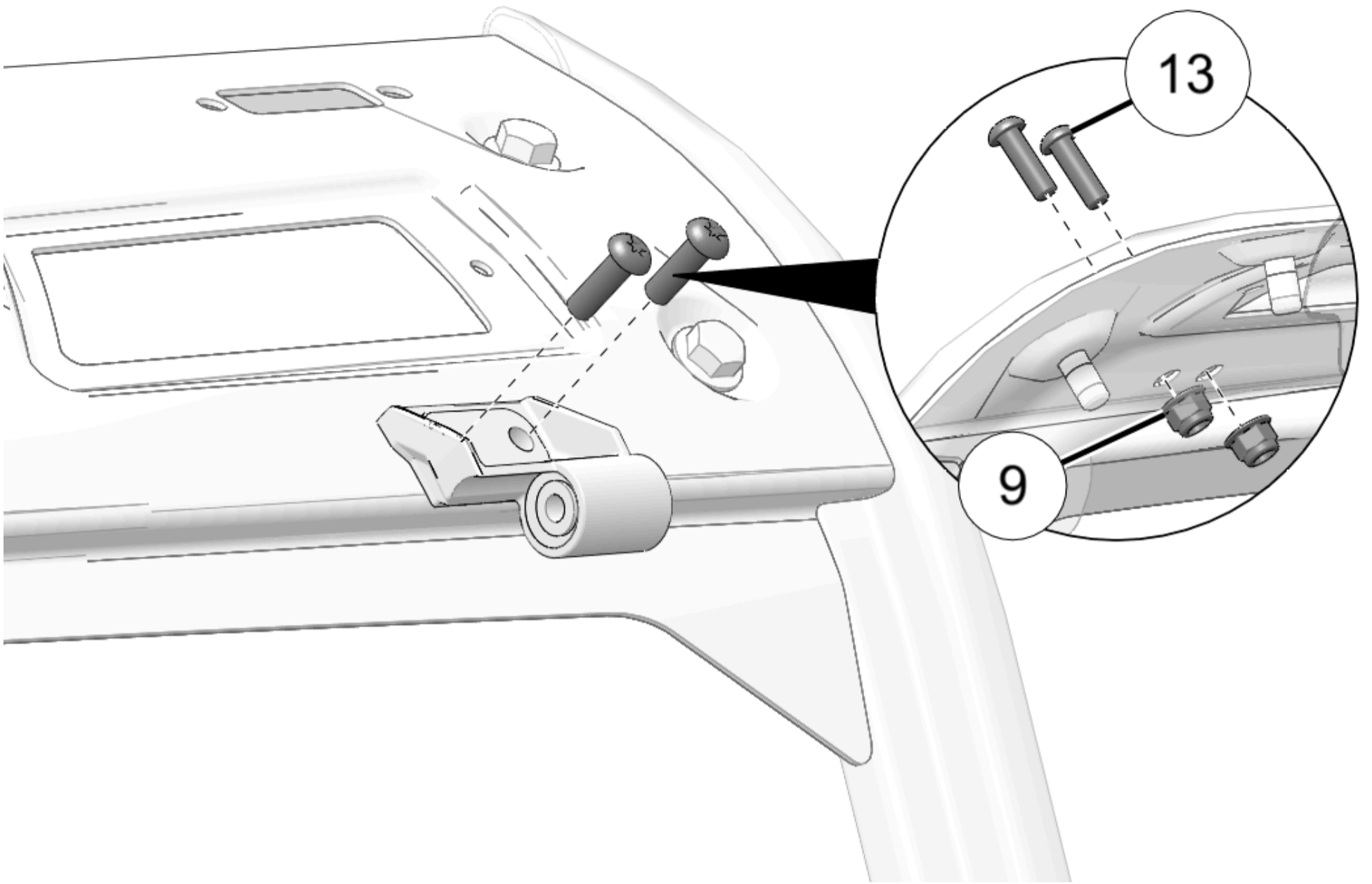

2. Set windshield ① onto vehicle.

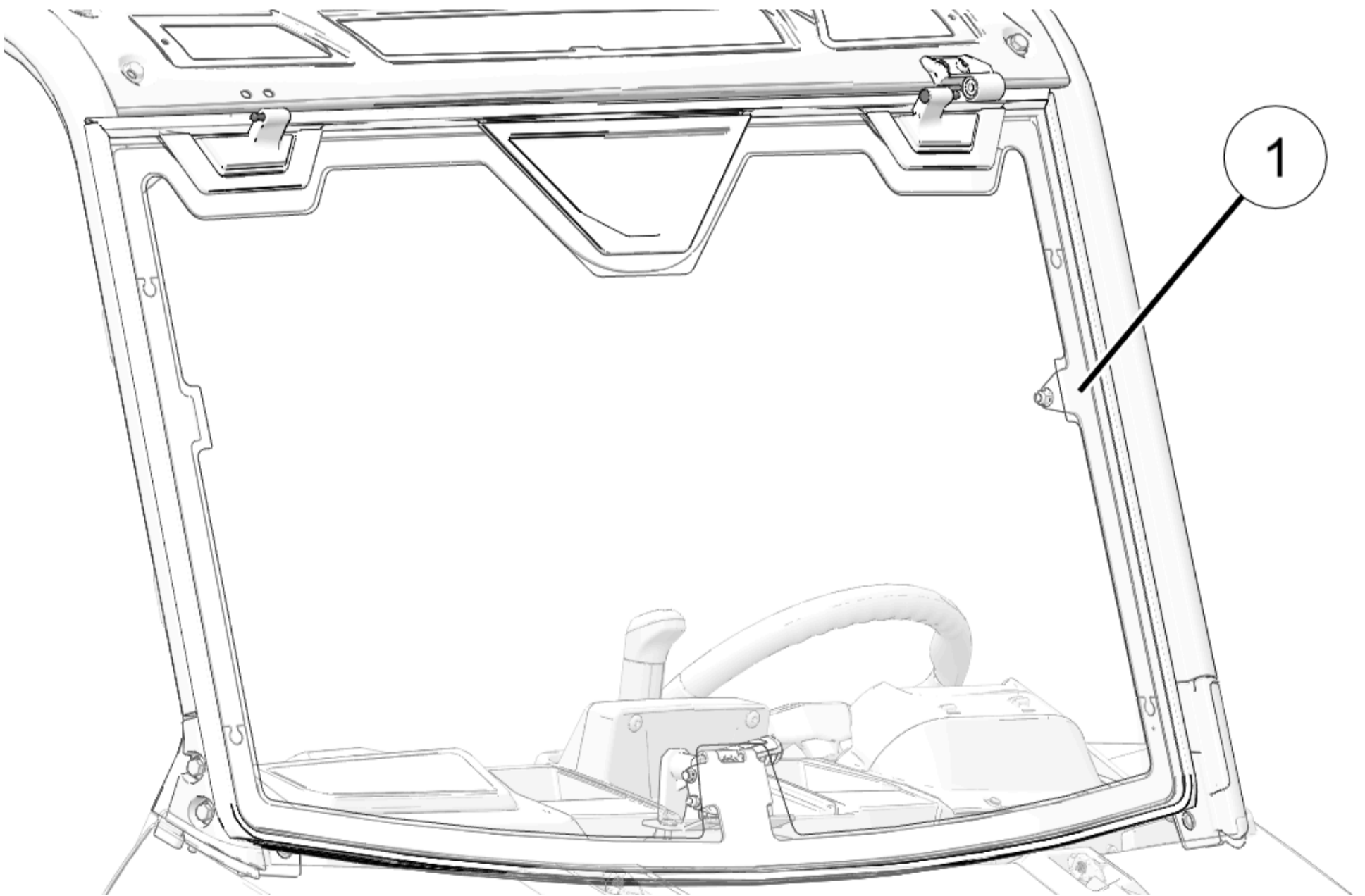

3. Move pin on left side windshield hinge into bushing on left side windshield mount ⑫.

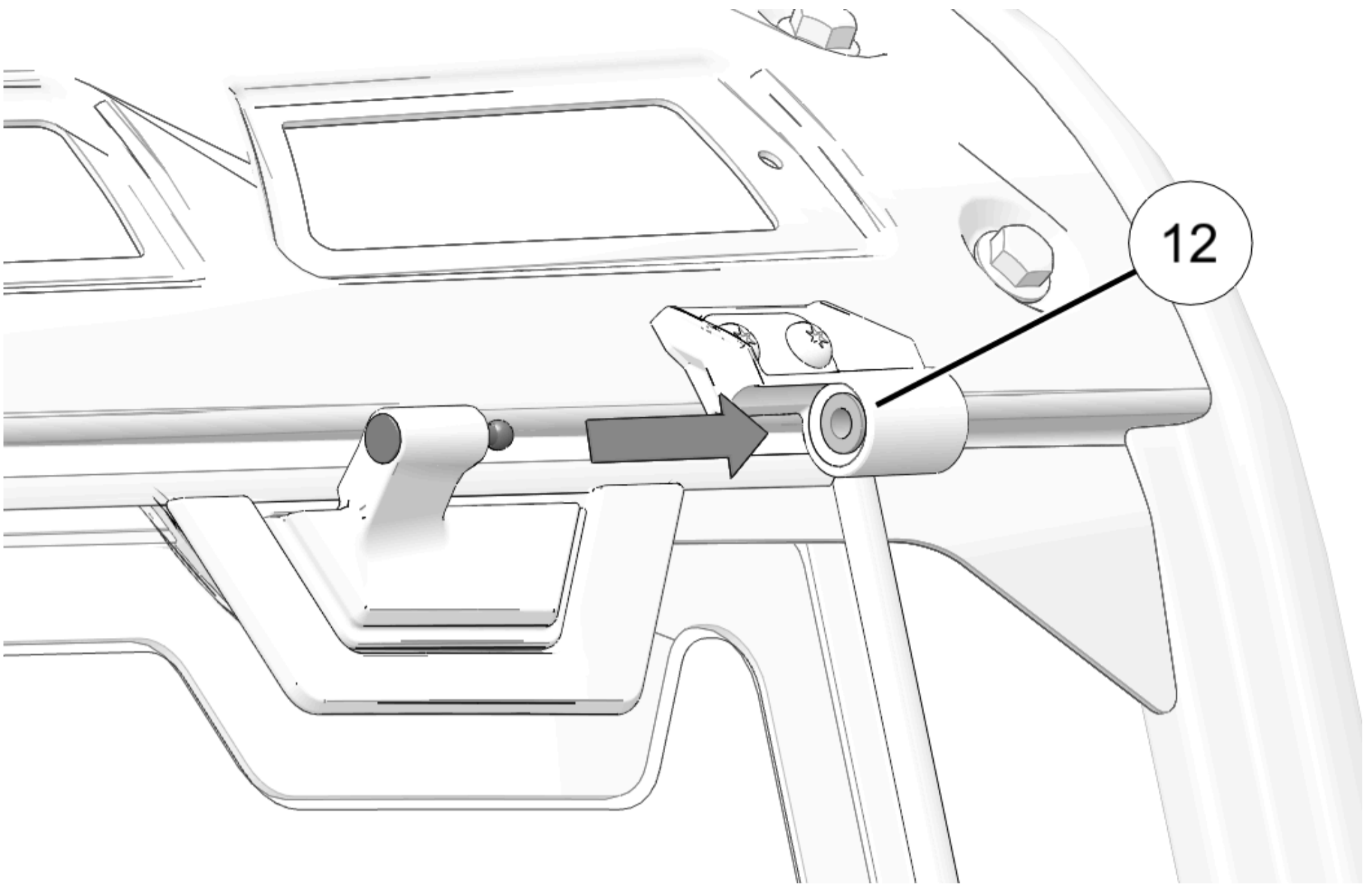

4. Install right side windshield mount bushing (11) onto right side windshield hinge pin.

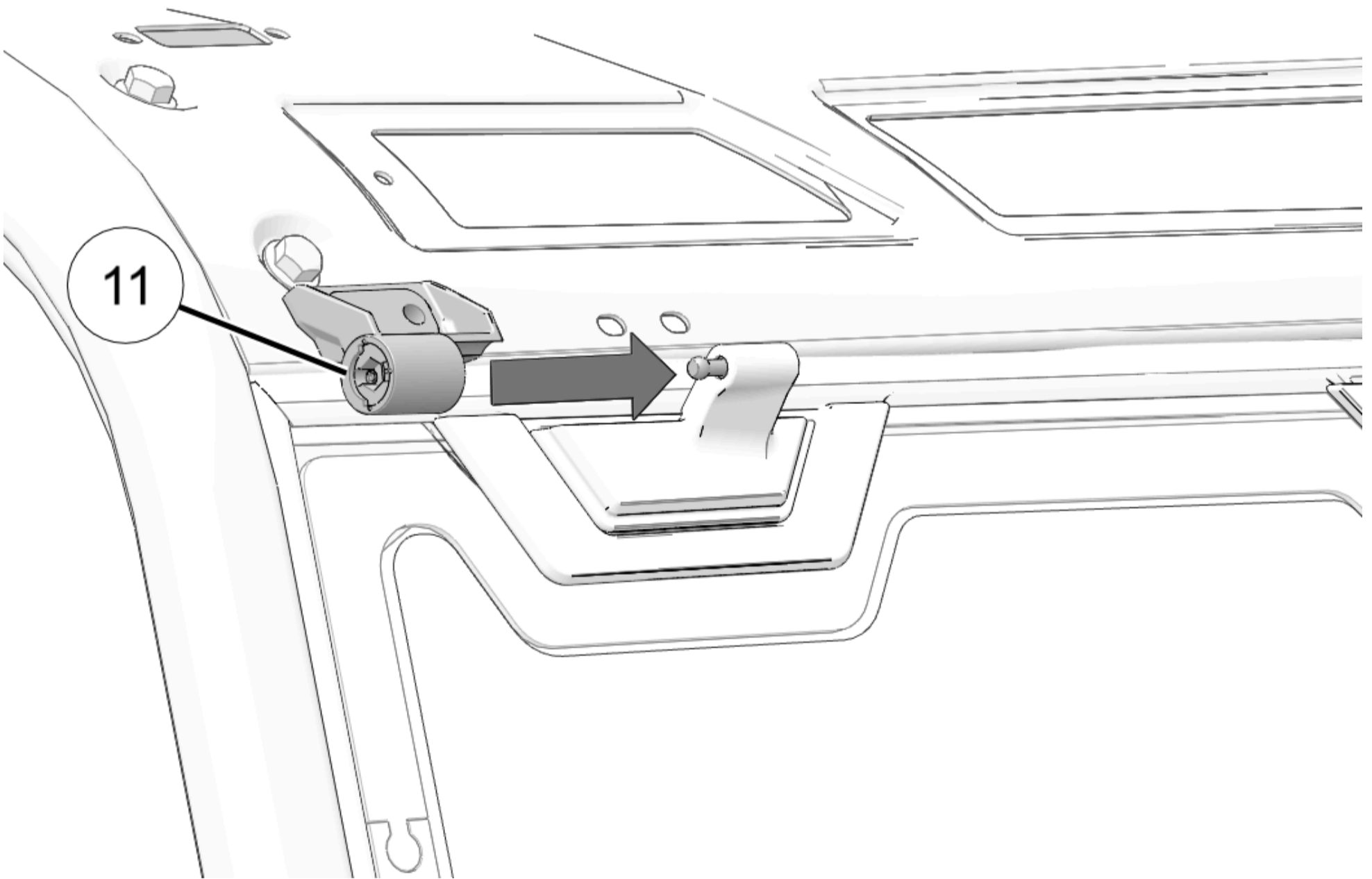

5. Install right side windshield mount (11) to upper ROPS with two screws (13) and two nuts (9).

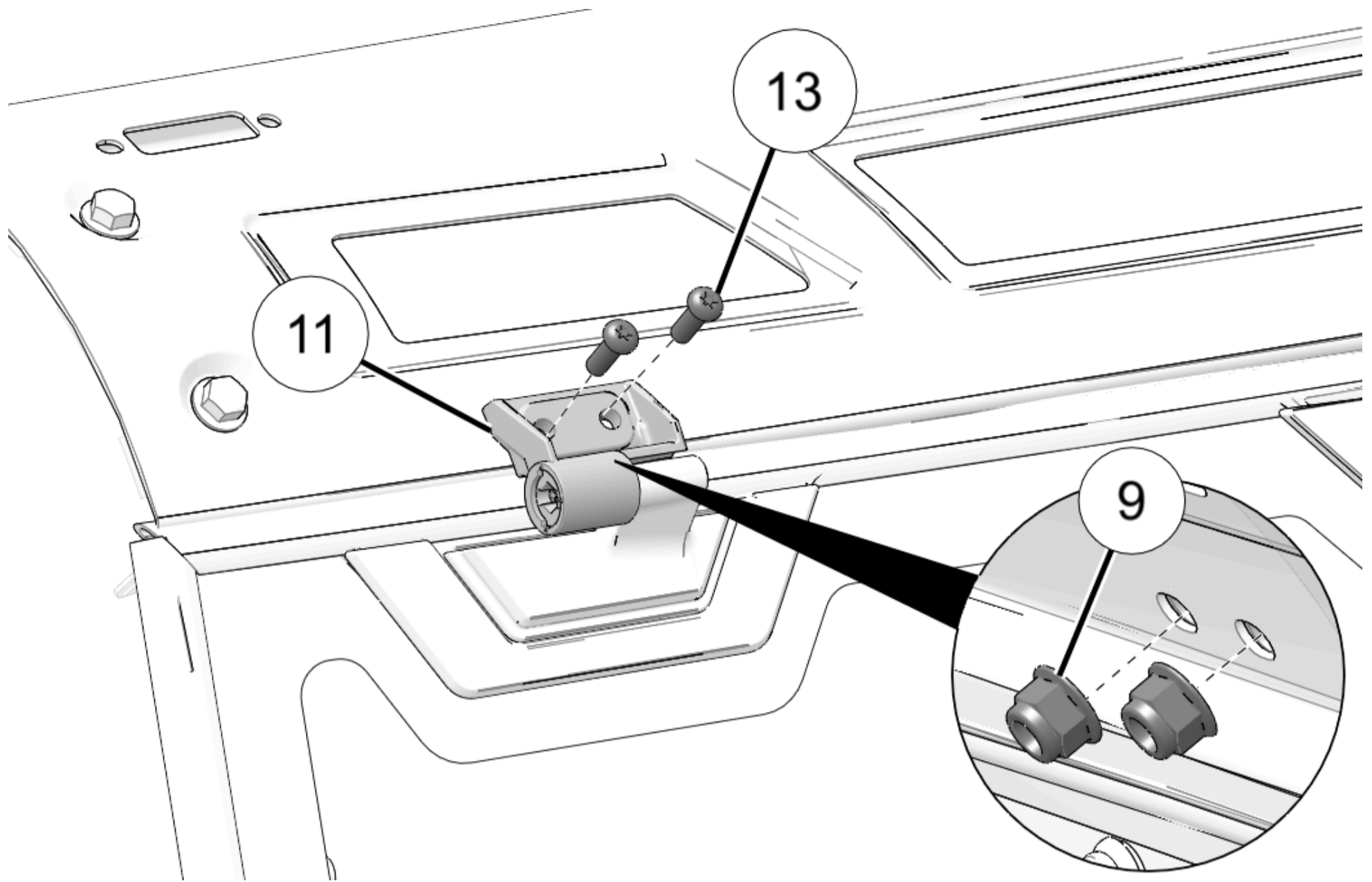

6. Torque two left side and two right side windshield mount nuts ⑨ to specification.

TORQUE

Windshield Mount Nuts ⑨:
20 ft-lbs (27 N·m)

Windshield Alignment

NOTICE

Left side shown; right side similar.

1. Loosen set screw ① on left side windshield mount ⑫.

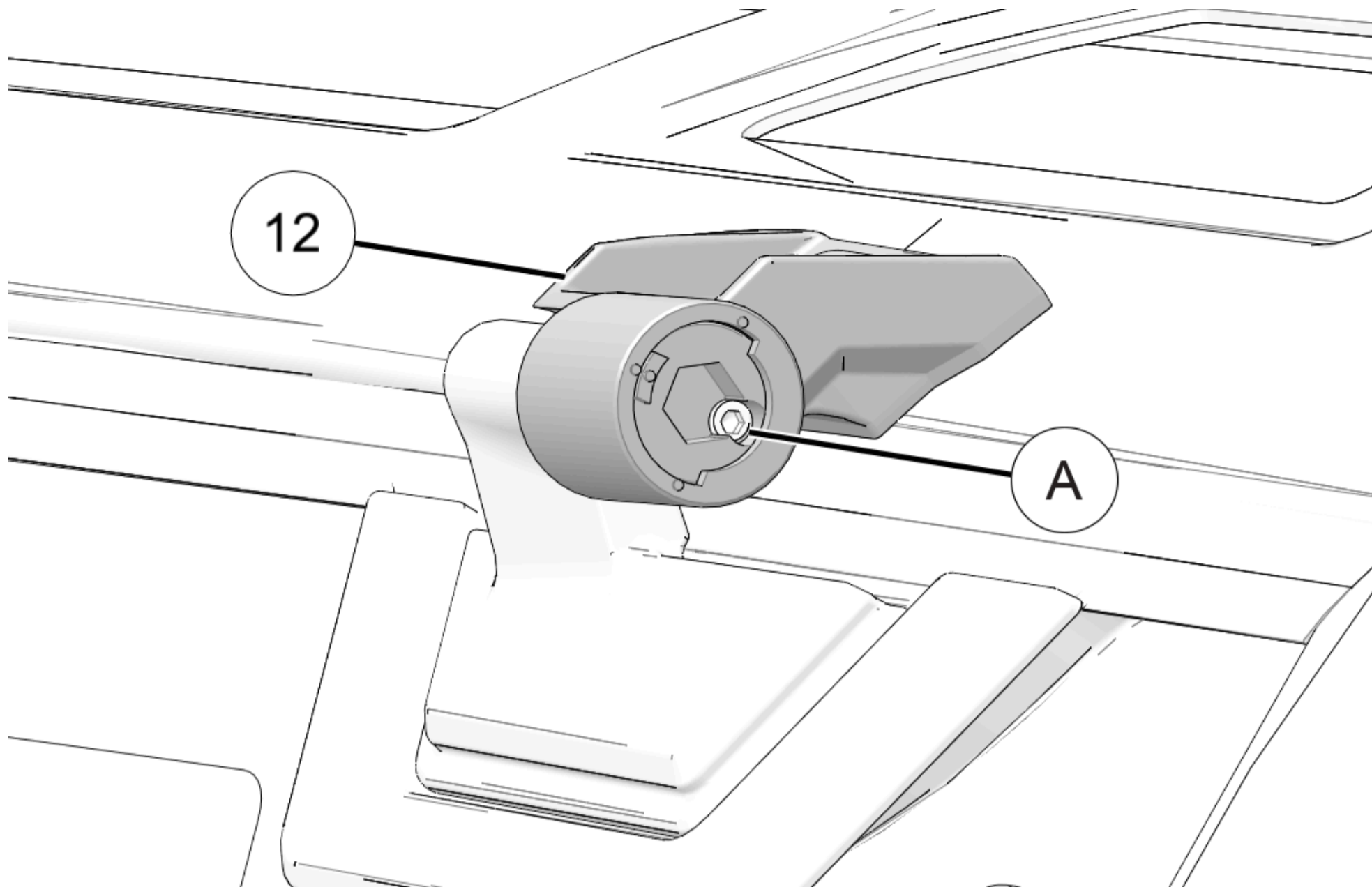

2. Turn hinge pin cam (B) in either direction to center the windshield on the vehicle.

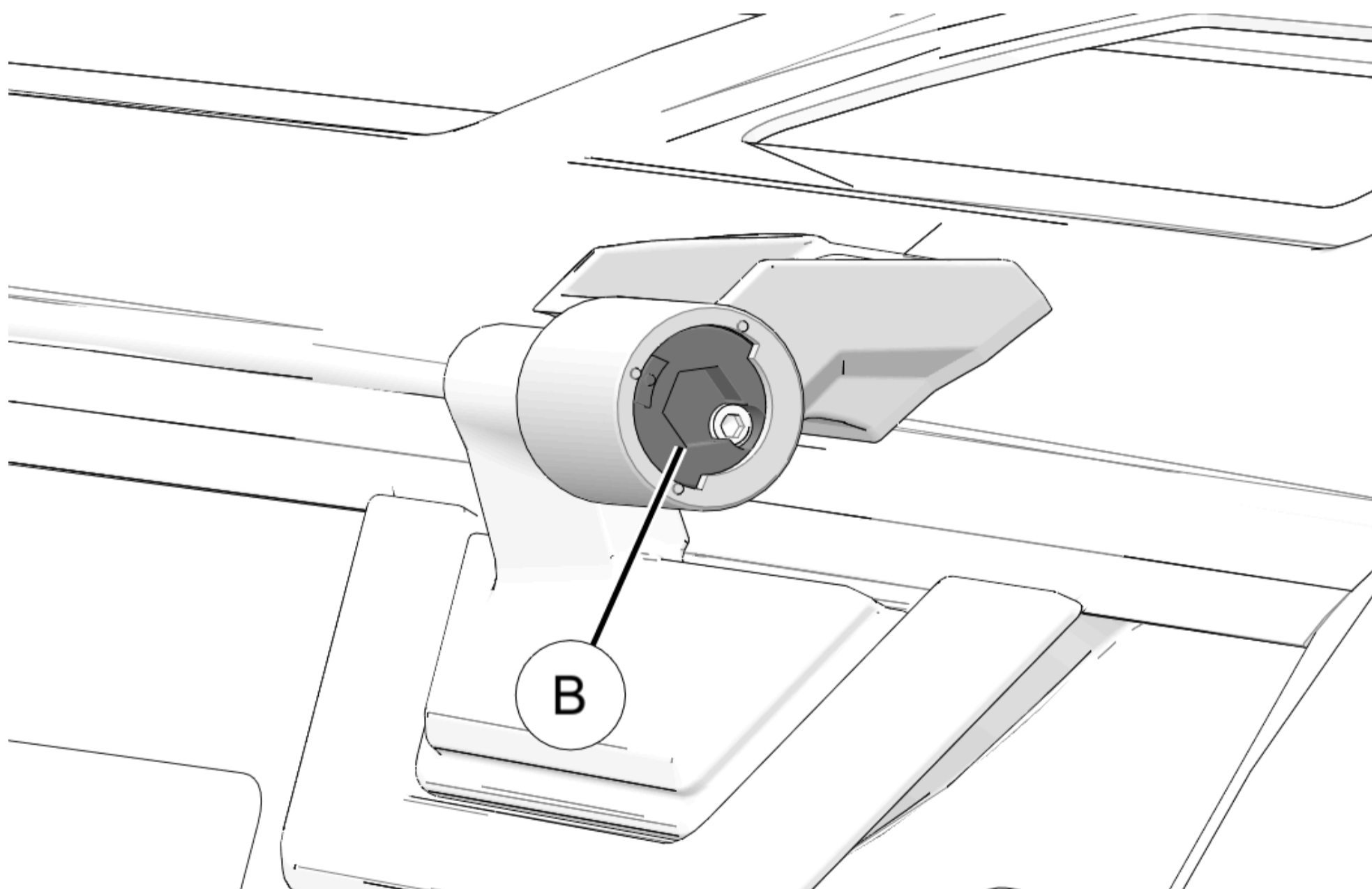

3. Tighten set screw (A) on left side windshield mount (12).

IMPORTANT

Do not over-tighten set screws.

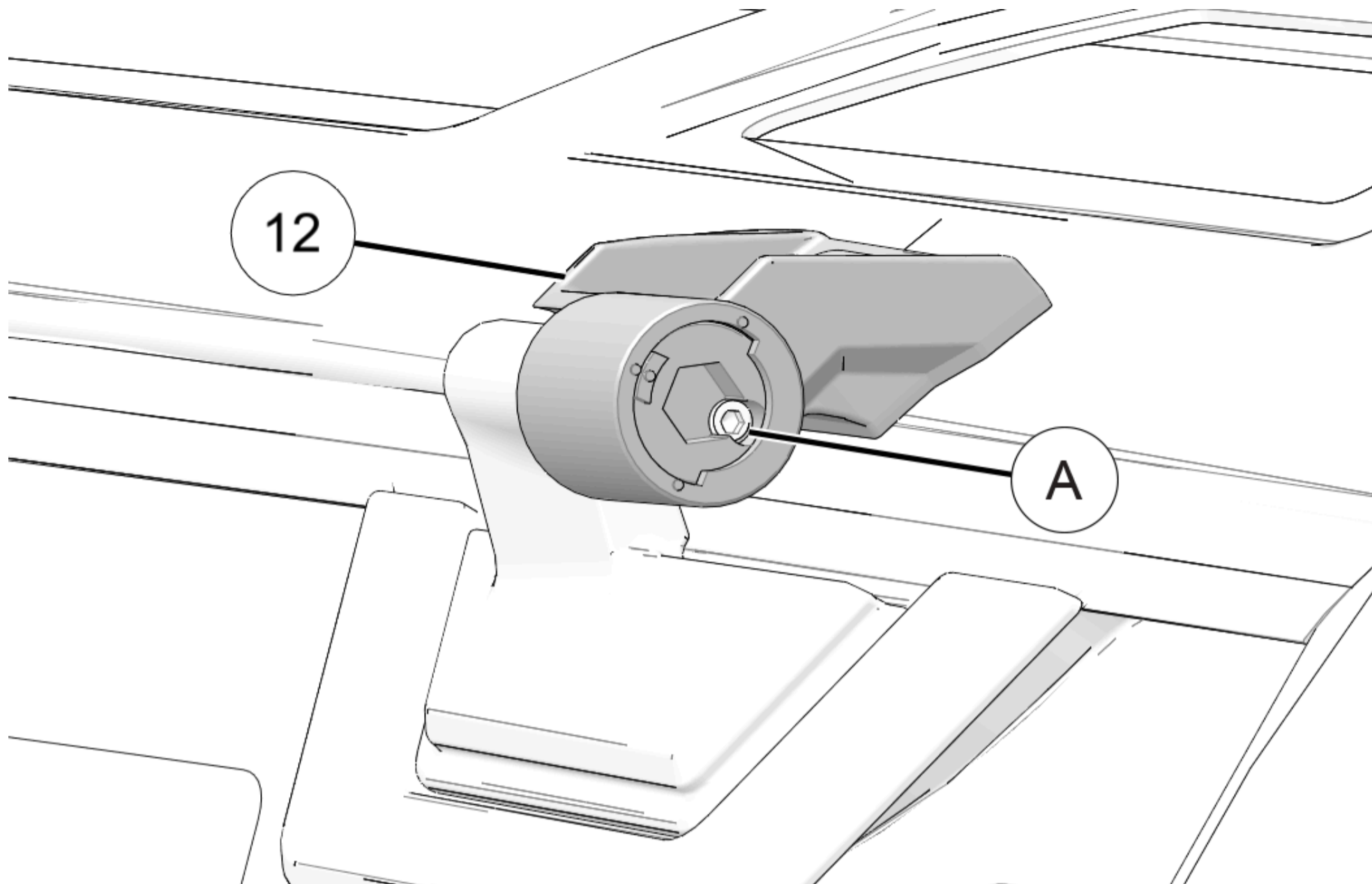

Shock Installation

NOTICE

Left side shown; right side similar.

1. Install ball fitting (8) to lower A-pillar with nut (9), as shown.

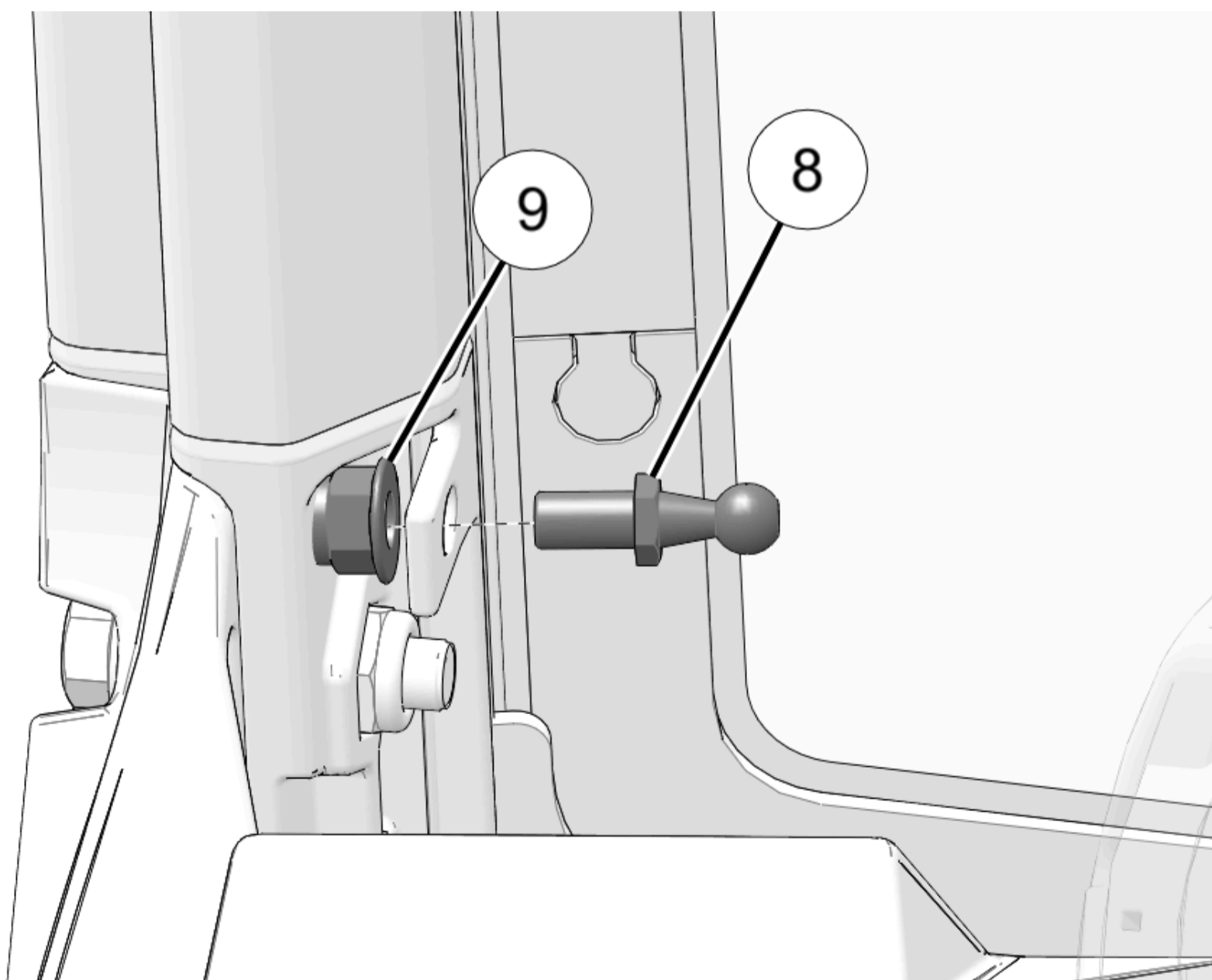

2. Tighten until fully seated.
3. Push lower shock rod (10) into lower ball fitting (8).

NOTICE

Retention clip will snap into place when shock is fully seated.

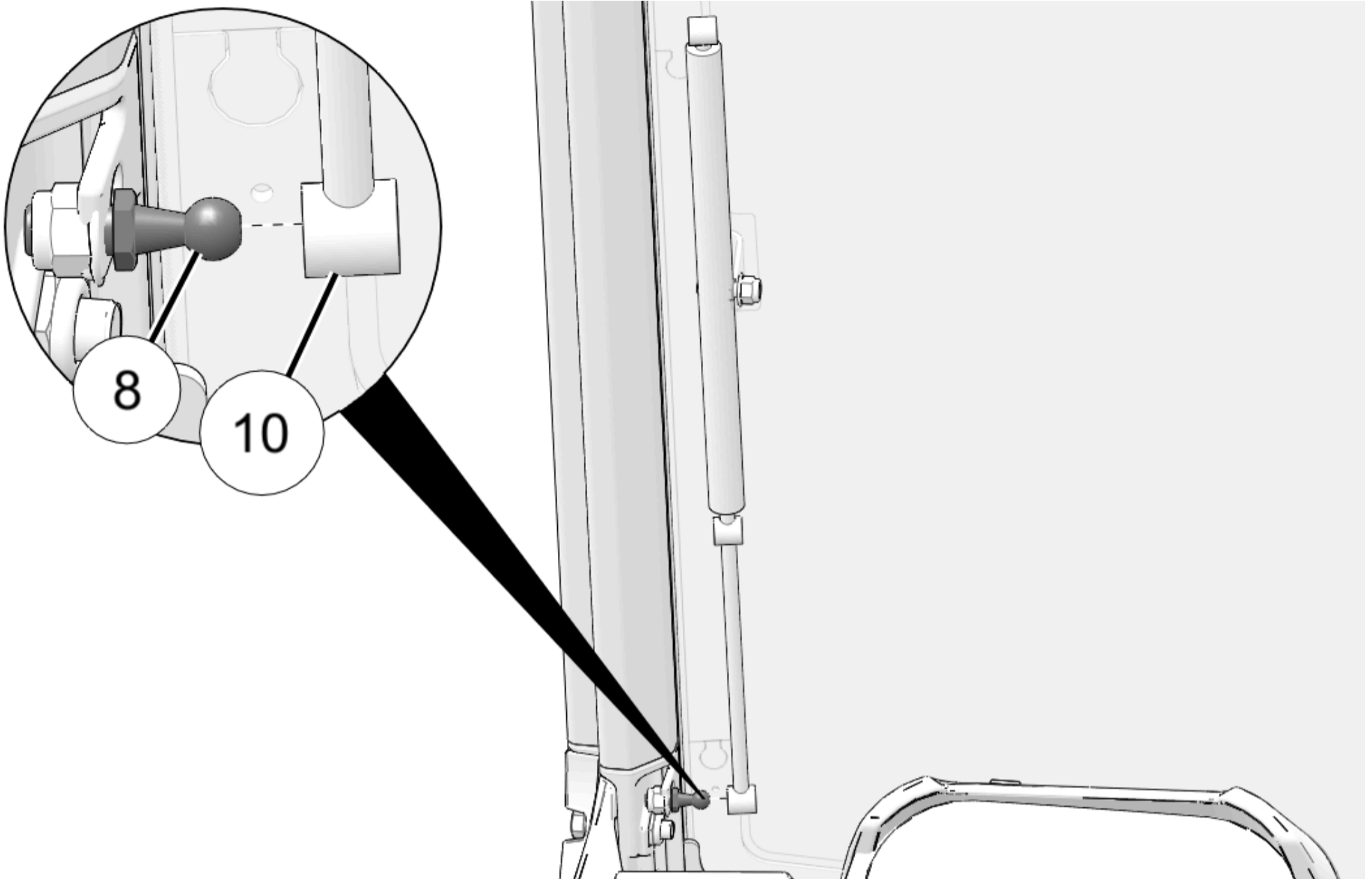

4. Open windshield and push upper shock cylinder (10) into upper ball fitting (8).

NOTICE

Retention clip will snap into place when shock is fully seated.

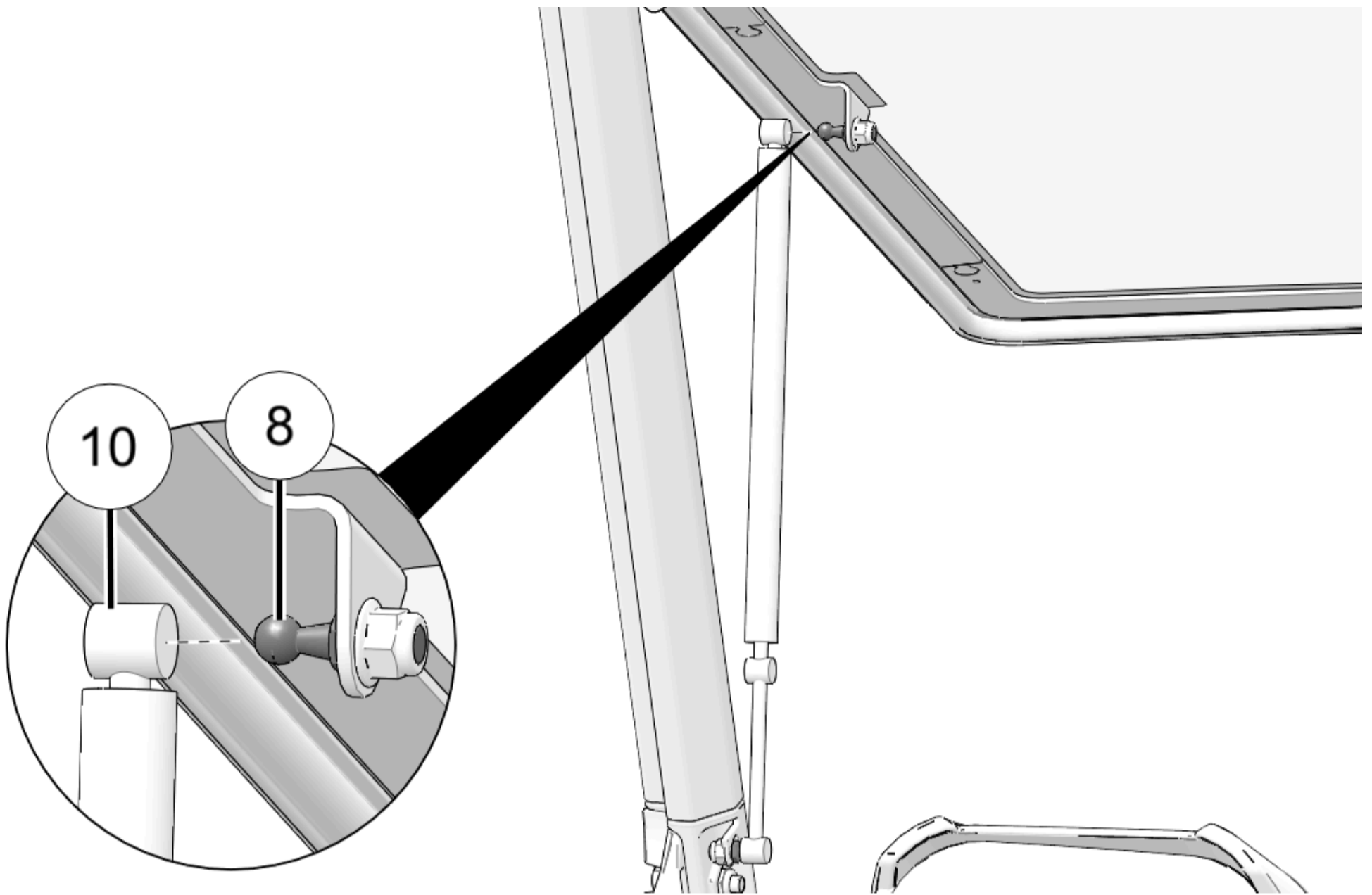

Shock Removal (optional)

1. If necessary to remove shock from ball fitting:

- put flat edge of screwdriver into opening beneath retention clip (E),
- turn to disengage clip ends from ball fitting while gently pulling shock away.

IMPORTANT

Do not remove clip. Lift clip just enough to disengage clip ends from ball fitting.

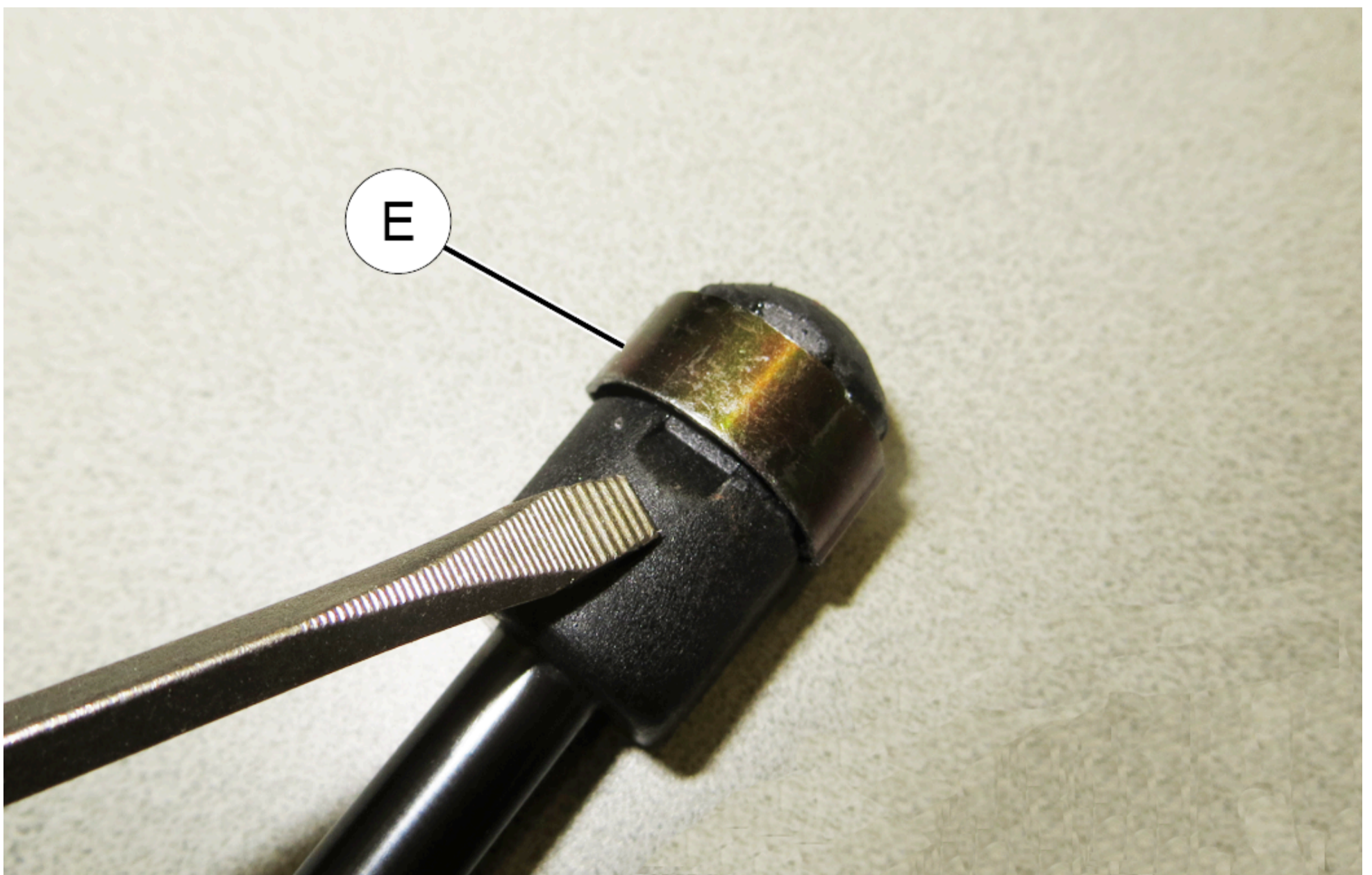

Operation

⚠ WARNING

If transporting vehicle in non-enclosed trailer, vehicle must FACE FORWARD and windshield must be FULLY CLOSED and LOCKED. Otherwise, windshield must be removed. Failure to comply may allow airflow, vibration, or other factors to separate windshield from vehicle and cause an accident, resulting in serious personal injury or death.

Open Windshield

1. Unlock windshield handle from handle base ⑥.

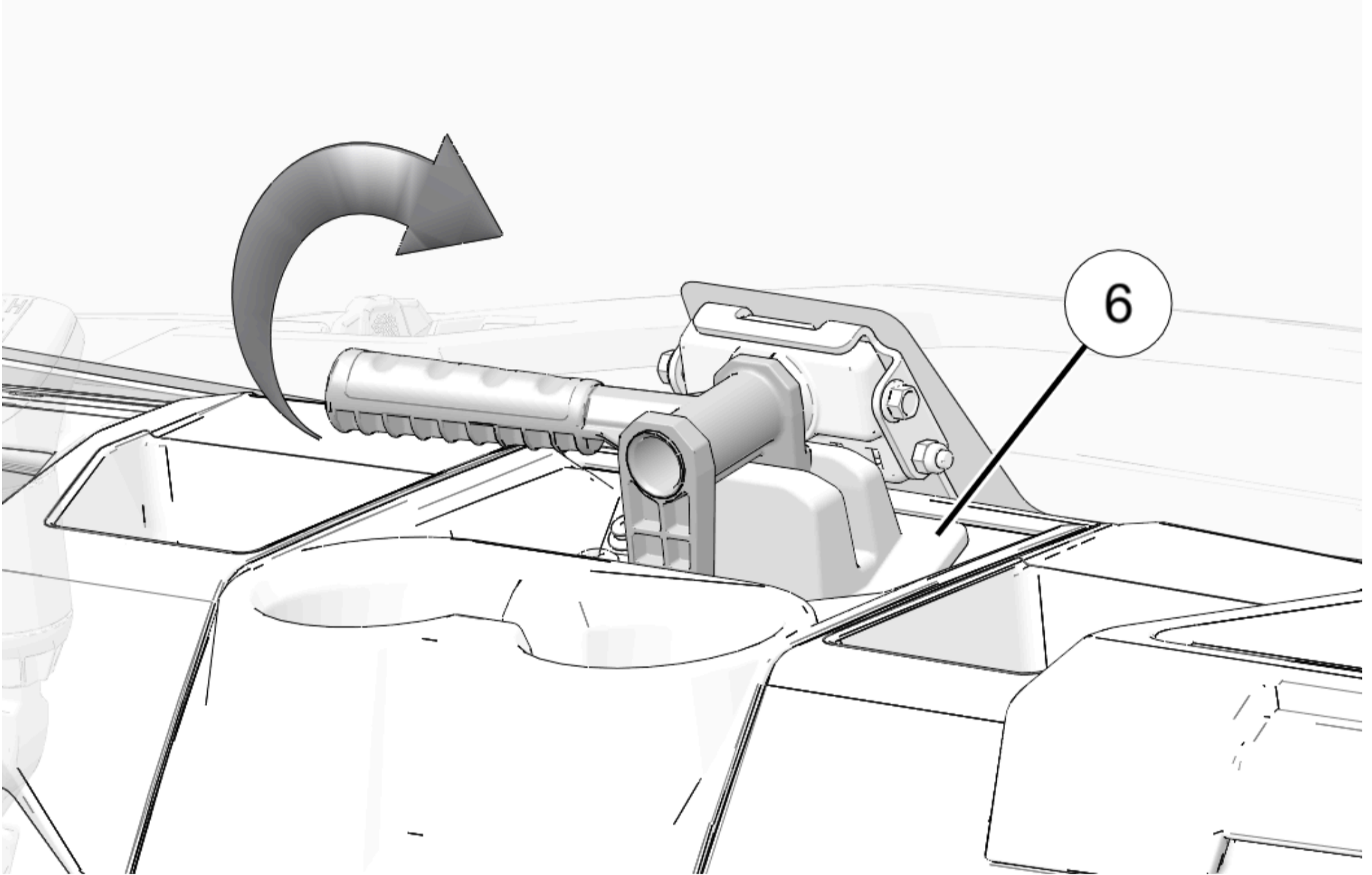

2. Open windshield.

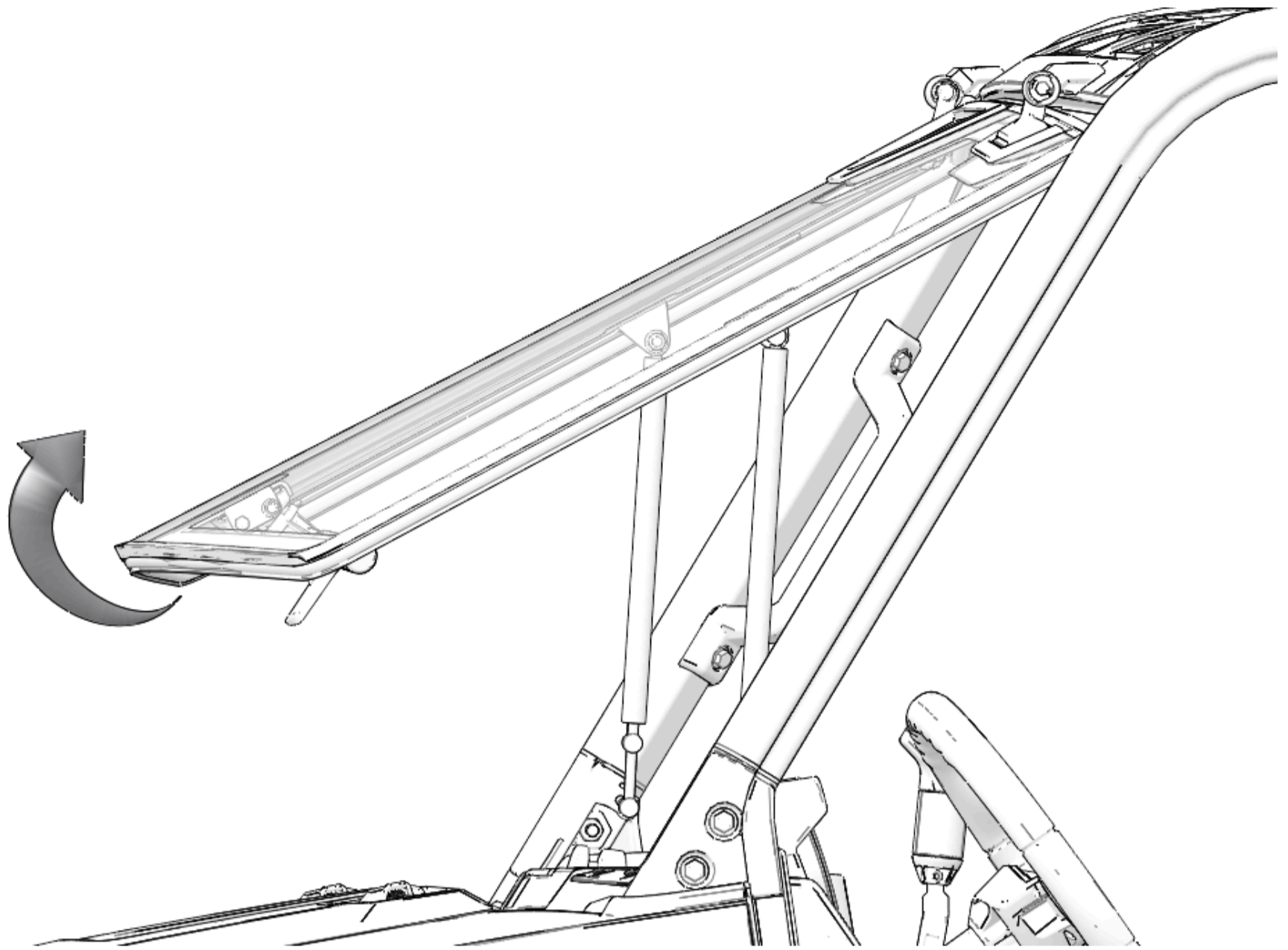

Vent Windshield

1. Unlock windshield handle from handle base ⑥.

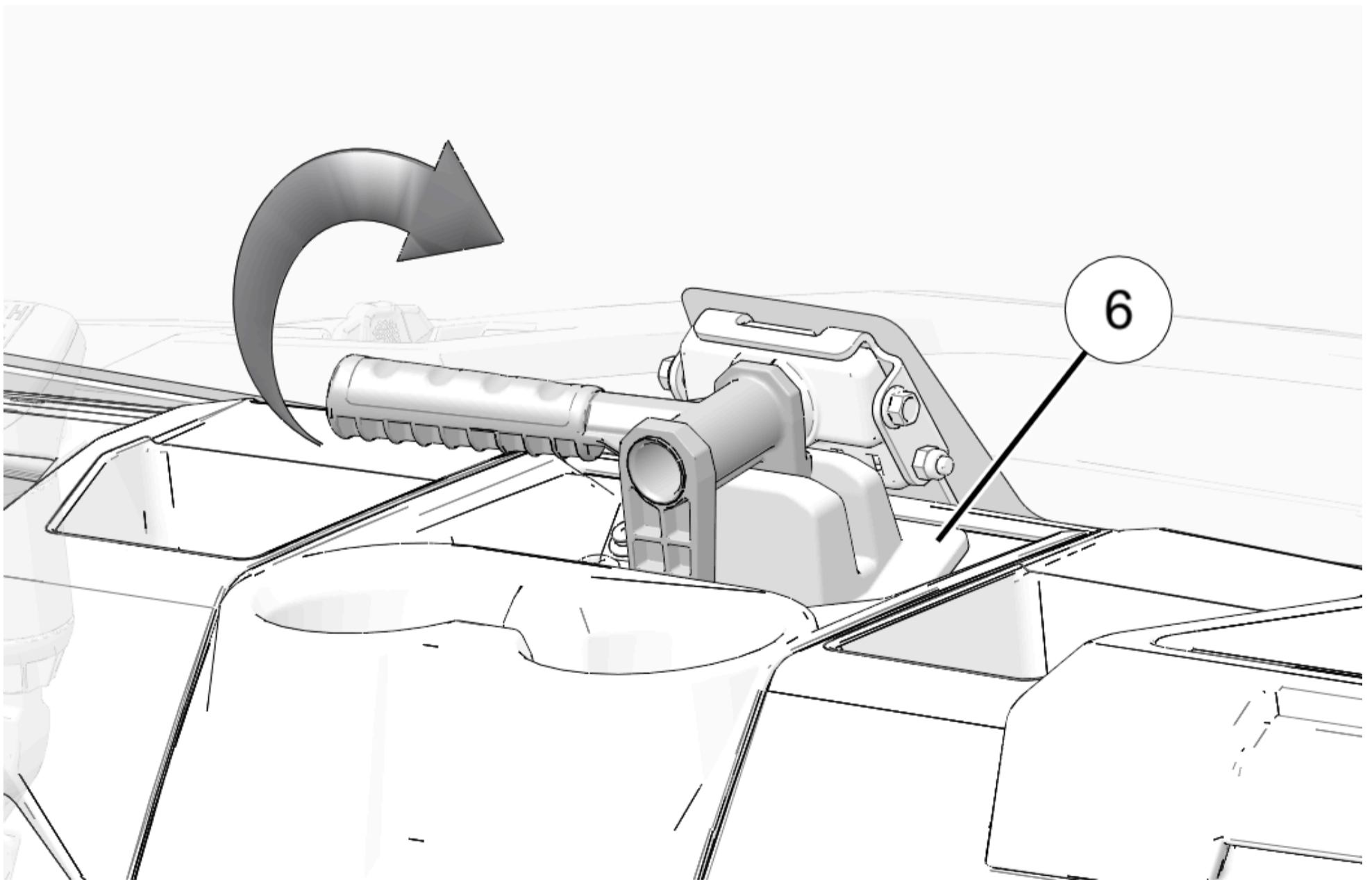

2. Move windshield handle forward and align handle legs over handle base ⑥ in the vented position, as shown.

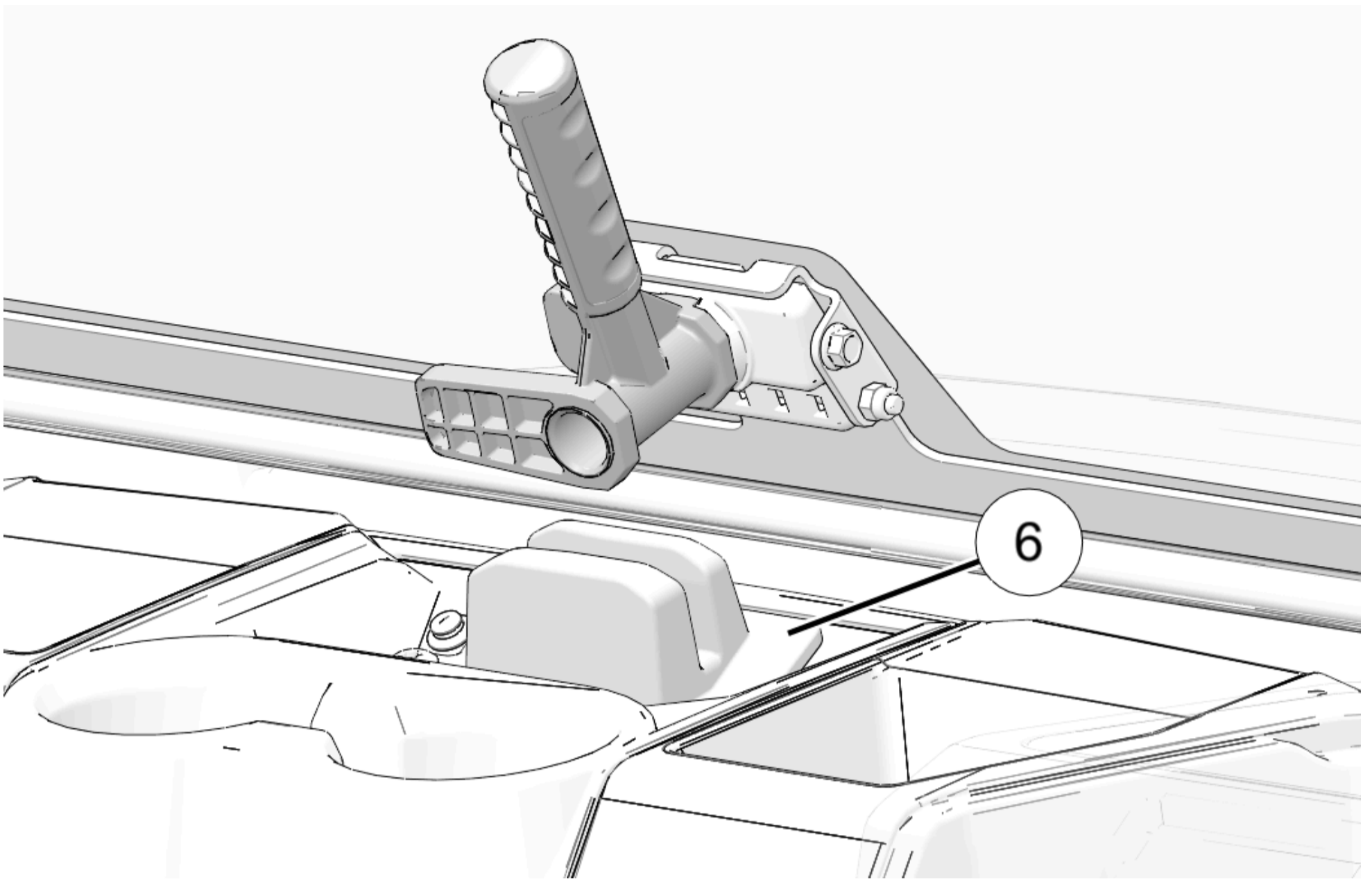

3. Lock windshield handle into handle base ⑥.

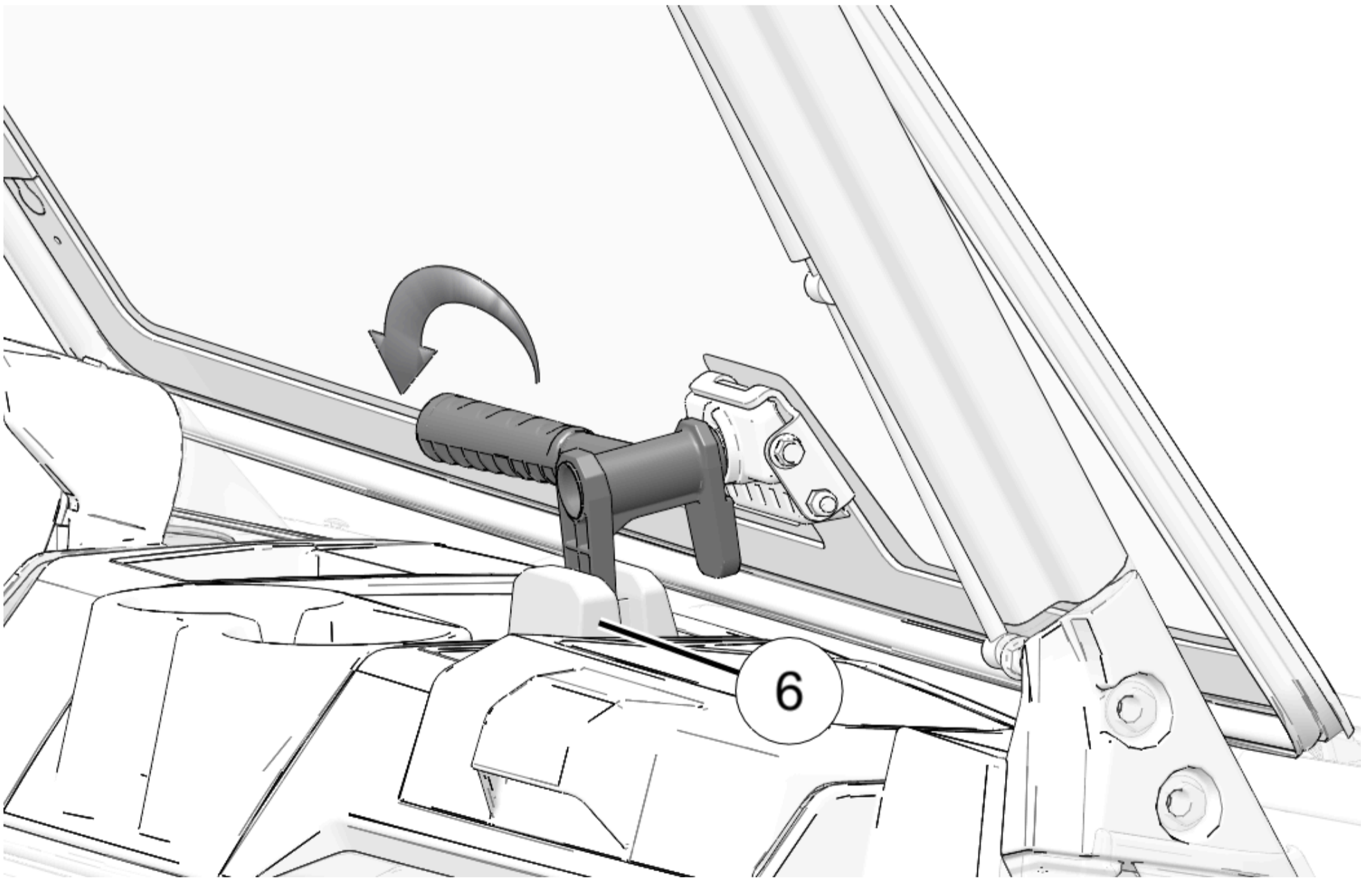

Close Windshield

1. Close windshield.

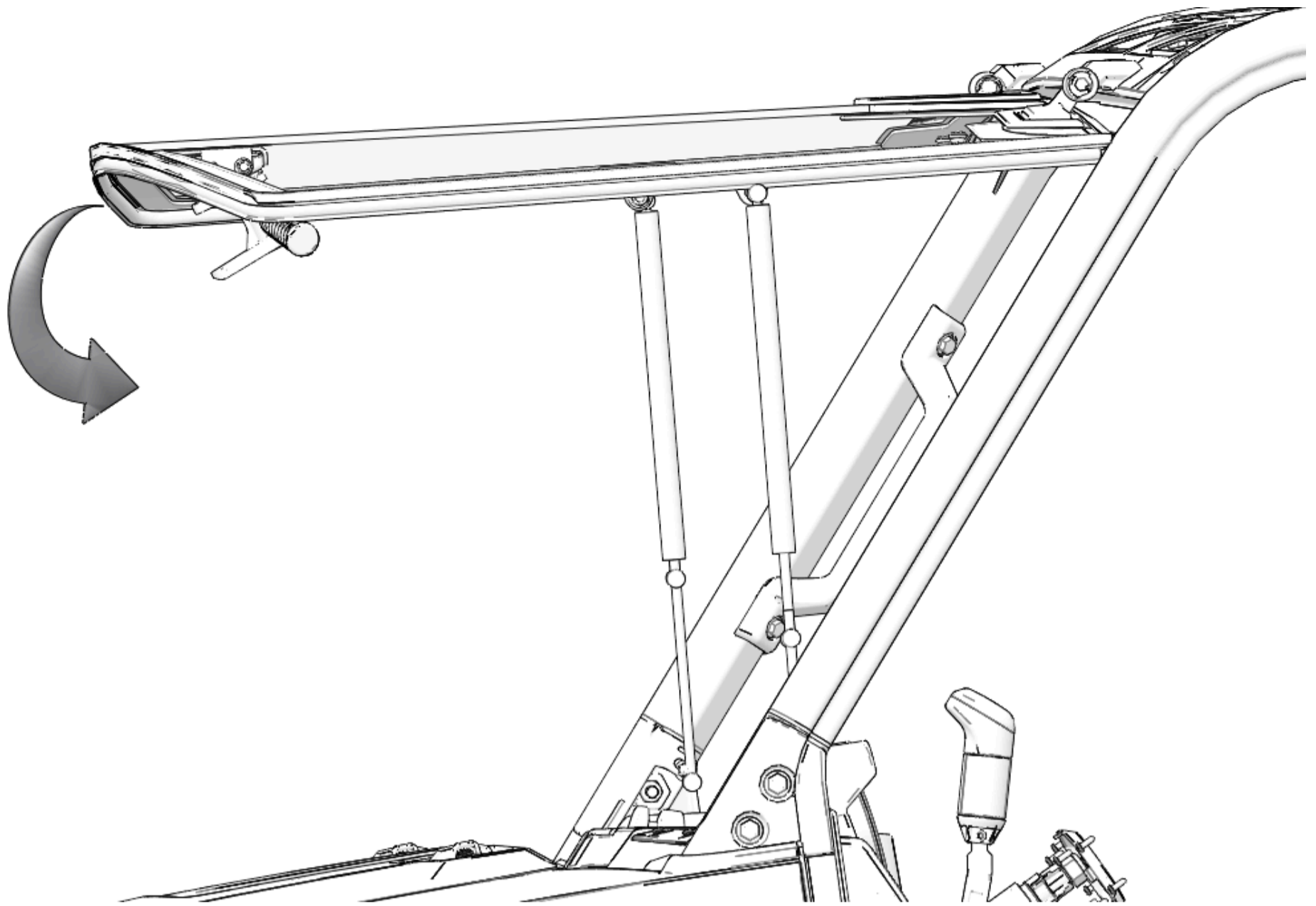

2. Lock windshield handle into handle base ⑥.

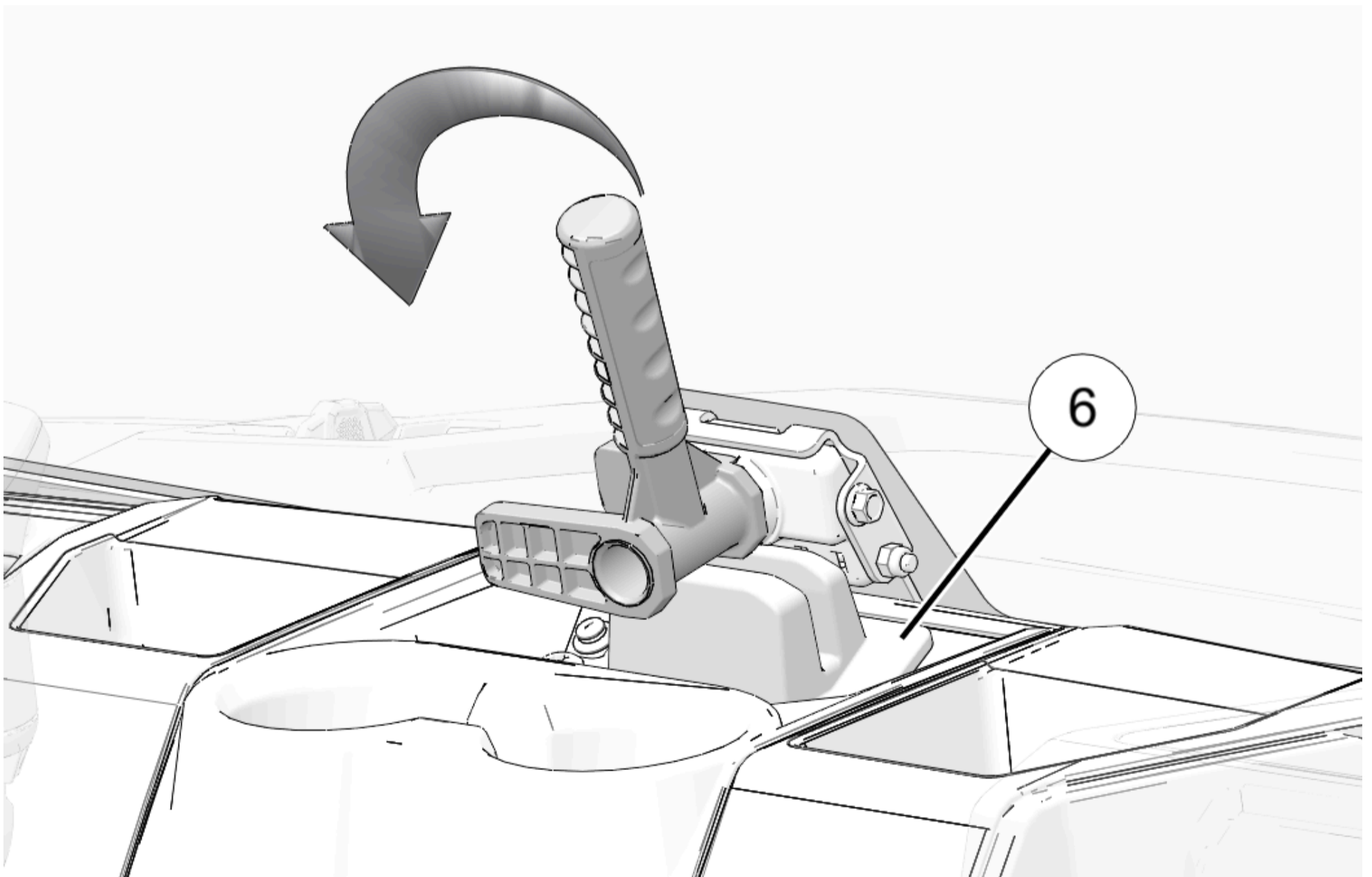

3. Make sure windshield seals are compressed and that the windshield opens and closes correctly. See Windshield Alignment section if adjustments are needed.

Instruction Feedback Form

A feedback form has been created for the installer to provide any comments, questions or concerns about the installation instructions. The form is viewable on mobile devices by scanning the QR code or by clicking [HERE](#) if viewing on a PC.



[Site Map](#)

[Privacy Policy](#)

[Accessibility](#)

© 2024 Polaris Inc.