

2023



For Maintenance and Safety

OWNER'S MANUAL

**RZR Turbo R
RZR Turbo R 4**

POLARIS
Think Outside



WARNING

Read, understand, and follow all of the instructions and safety precautions in this manual and on all product labels.

Failure to follow the safety precautions could result in serious injury or death.



WARNING

Operating, servicing, and maintaining a passenger vehicle or off-road vehicle can expose you to chemicals including engine exhaust, carbon monoxide, phthalates, and lead, which are known to the State of California to cause cancer and birth defects or other reproductive harm. To minimize exposure, avoid breathing exhaust, do not idle the engine except as necessary, service your vehicle in a well-ventilated area and wear gloves or wash your hands frequently when servicing your vehicle.

For more information go to www.P65Warnings.ca.gov/passenger-vehicle.



*For videos and more information
about a safe riding experience with
your Polaris vehicle, scan this QR
code® with your smartphone
or visit: www.polaris.com/en-us/safety/*

POLARIS

RZR

2023 RZR Owner's Manual

Turbo R

Sport

Premium

Ultimate

Turbo R 4

Sport

Premium

Ultimate

Unless noted, trademarks are the property of Polaris Industries Inc.

Recreational Off-Highway Vehicle Association® and ROHVA® are registered trademarks of the Recreational Off-Highway Vehicle Association. WALKER EVANS RACING® is a registered trademark of Walker Evans Enterprises Incorporated. Tread Lightly® is a registered trademark of the United States Department of Agriculture. BatteryMINDer® is a registered trademark of VDC Electronics Inc. Loctite® is a registered trademark of Henkel Corporation. NYOGEL® is a registered trademark of Nye Lubricants, Inc. WD-40® is registered to WD-40 Manufacturing Company. QR Code® is a registered trademark of DENSO WAVE INCORPORATED. Sandisk® is a registered trademark of SANDISK LLC. Google Play® is a registered trademark of Google, LLC. Apple® and App Store® is a registered trademark of Apple Inc. NGK® is a registered trademark of NGK Spark Plug Co., Ltd. OSHA® is a registered trademark of the Occupational Safety and Health Administration, U. S. Dept. of Labor. FOX® is a registered trademark of Fox Factory Inc. Bluetooth® is a registered trademark of Bluetooth Sig, Inc. exFAT® is a registered trademark of Microsoft Corporation. ANSI® is a registered trademark of American National Standards Institute, Inc. Sachs® is a registered trademark of ZF Friedrichshafen AG.

Copyright 2022 Polaris Industries Inc. All information contained within this publication is based on the latest product information at the time of publication. Due to constant improvements in the design and quality of production components, some minor discrepancies may result between the actual vehicle and the information presented in this publication. Depictions and/or procedures in this publication are intended for reference use only. No liability can be accepted for omissions or inaccuracies. Any reprinting or reuse of the depictions and/or procedures contained within, whether whole or in part, is expressly prohibited.

The original instructions for this vehicle are in English. Other languages are provided as translations of the original instructions.

Printed in U.S.A.

9954282 R01



Thank you for purchasing a POLARIS vehicle, and welcome to our world-wide family of POLARIS enthusiasts. Be sure to visit us online at www.polaris.com for the latest news, new product introductions, upcoming events, career opportunities and more.

Here at POLARIS we proudly produce an exciting line of utility and recreational products. We believe POLARIS sets a standard of excellence for all utility and recreational vehicles manufactured in the world today. Many years of experience have gone into the engineering, design, and development of your POLARIS vehicle.

For safe and enjoyable operation of your vehicle, be sure to follow the instructions and recommendations in this owner's manual. Your manual contains instructions for minor maintenance, but information about major repairs is outlined in the POLARIS Service Manual and can be performed by a factory certified Master Service Dealer (MSD) technician.

Your POLARIS dealer knows your vehicle best and is interested in your total satisfaction. Your POLARIS dealership can perform all of your service needs during and after the warranty period.

For the most up-to-date owner's manual visit <https://www.polaris.com/en-us/owners-manuals>.

SAFETY SYMBOLS AND SIGNAL WORDS

The following signal words and symbols appear throughout this manual and on your vehicle. Your safety is involved when these words and symbols are used. Become familiar with their meanings before reading the manual.

DANGER

DANGER indicates a hazardous situation which, if not avoided, WILL result in death or serious injury.

WARNING

WARNING indicates a hazardous situation which, if not avoided, COULD result in death or serious injury.

CAUTION



CAUTION indicates a hazardous situation which, if not avoided, COULD result in minor to moderate injury.

NOTICE

NOTICE provides key information by clarifying instructions.

IMPORTANT

IMPORTANT provides key reminders during disassembly, assembly, and inspection of components.

ICON	DESCRIPTION
	The Prohibition Safety Sign indicates an action NOT to take in order to avoid a hazard.
	The Mandatory Action Sign indicates an action that NEEDS to be taken to avoid a hazard.

Introduction	7
Safety	9
Features and Controls	31
Ride Command Display (if equipped)	71
Operation	83
Emission Control Systems	87
Maintenance	89
Specifications	151
Polaris Products	157
Troubleshooting	159
Warranty	183
Maintenance Log	193

INTRODUCTION

TOOLS FOR SAFE RIDING

To safely operate this vehicle, it is important to become familiar with its features, controls, and characteristics. Review the Safety Briefings for this vehicle that apply to you:

- Operators
- Riders
- Owners
- Trailering the Vehicle
- Maintaining the Vehicle

Additionally, read the product safety labels on the vehicle and follow all rules and regulations concerning the operation of this vehicle in your area.

POLARIS recommends anyone who will be operating this vehicle to take a training course. ROHVA® (Recreational Off-Highway Vehicle Association®) provides both an online safety e-course and a hands-on safety course. To access this training, visit www.rohva.org.

Other sources of safety information include the POLARIS Safety Video. The POLARIS Help Center also has additional information: <https://RZR.polaris.com/en-us/self-help>

VEHICLE TESTING

This Off-Road Vehicle was subjected to the following tests of the National Standard for Recreational Off-Highway Vehicles, ANSI®/ROHVA® 1-2016:

- Maximum Speed Capability
- Service Brake Performance
- Parking Brake/Mechanism Performance
- Lateral Stability
- Pitch Stability
- Vehicle Handling
- Roll Over Protective Structure (ROPS)
- Occupant Retention System (ORS)
- Sound Level Limits

INTRODUCTION

VEHICLE IDENTIFICATION NUMBERS

Record your vehicle's identification number ①, engine serial number ②, and key number in the spaces provided. Remove the spare key and store it in a safe place. An ignition key can be duplicated only by ordering a POLARIS key blank (using your key number) and mating it with one of your existing keys. The ignition switch must be replaced if all keys are lost.

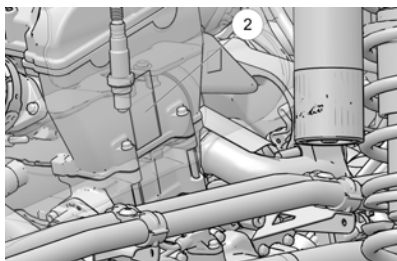
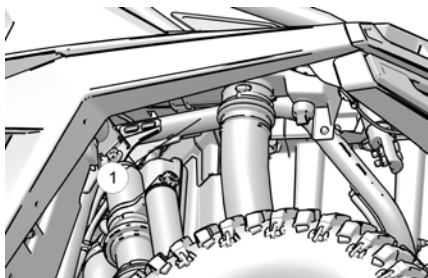

Vehicle Model Number:	
Vehicle Identification Number:	
Engine Serial Number:	
Key Number:	

SAFETY

OWNER REQUIREMENTS

Improper use, maintenance, or modification of this vehicle can lead to serious injury or death.

Require proper use of your vehicle. Do not allow anyone to operate your vehicle or ride as a passenger unless they are properly instructed and you are sure they are willing to ride responsibly. To prevent unauthorized use, always remove the ignition key when the vehicle is not in use.



Any modifications or installation of non-POLARIS-approved accessories could increase the risk of injury. While you may find aftermarket products similar in design and quality to POLARIS accessories, recognize that some aftermarket accessories or modifications are not suitable because of potential safety hazards to you or others. It is never appropriate to install any additional seating.

Check with the manufacturer to determine any potential effect of a modification or accessory on the safe use of your vehicle. You are responsible for injuries related to modifications to the vehicle. Modifications or accessories may:

- Damage machine components - especially modifications that increase speed or power.
- Make the vehicle less stable at higher speeds.
- Add weight, reducing the amount of cargo and total weight you can carry, and raise the vehicle's center of gravity.
- Overload the vehicle's electrical system capacity. Blowing a fuse may cause a loss of lights or engine power.
- Reduce the effectiveness of occupant protection systems, including the seatbelts and the Rollover Protective Structure (ROPS).
- Make it illegal to own or operate your vehicle. POLARIS-authorized spark arresters, mufflers, and emissions control components are mandatory for ownership or operation in many areas.
- Void your warranty.

The vehicle ROPS, when used with the seat belts and doors, provides a structure to help protect occupants. The structure will not protect occupants in all rollovers or accidents.

DRIVER AND PASSENGER QUALIFICATIONS

Make sure operators are 16 or older with a valid driver's license. Just because a teenager has a license does not mean that they will make good judgments about driving and avoid risk taking.



POLARIS recommends that you supervise younger drivers. Set rules and put limits on how, when, and where they are allowed to use this vehicle. For example, young drivers may need to have an adult in the vehicle with them and not be allowed to drive with their friends in the vehicle.

Make sure all riders fit the vehicle. Be sure that the driver and all passengers are able to:

- sit with their backs against their seat,
- adjust the seat belt to fit properly,
- have both feet flat on the floor, and
- have both hands on the steering wheel or on a passenger hand hold.

Do not allow children who need child safety seats or booster seats to ride in the vehicle. The vehicle is not designed to restrain automotive child safety seats.

You are responsible for your passengers. Be sure passengers are seated properly, belted, holding the passenger hand hold, and ready to brace. Unrestrained riders can fall out or be thrown around and from a moving vehicle.

Every person must be properly seated and belted in their own seat. Two people should never be belted into a single seat belt. People belted together can crash into one another in a collision and be seriously injured. Never carry passengers in the cargo bed as they could be thrown against or out of the vehicle or come into contact with moving parts.

Do not let people drive or ride after using alcohol or drugs.

PREPARE VEHICLE FOR THE RIDE

Before starting off, always perform the Pre-Ride Inspection. Failure to inspect and verify that the vehicle is in safe operating condition increases the risk of an accident, which can lead to serious injury or death.



ITEM	REMARK	REFERENCE
Brake Fluid	Ensure proper level and condition	page 126
Front and rear suspension	Inspect, lubricate if necessary	page 95
Steering	Ensure free operation	page 95
Tires	Inspect condition and pressure	page 29 page 134
Wheels/Lug Nuts	Inspect, ensure fastener tightness	page 135
Fuel and oil	Ensure proper levels and condition	page 98
Coolant	Ensure proper level and condition	page 114
Indicator lights/switches	Ensure proper operation	page 37 page 59
Air Filter	Inspect, replace as needed	page 121
Engine intake pre-filter	Inspect, clean	page 120
PVT intake pre-filter	Inspect, clean	page 116
Headlights	Check operation	–
Brake lights/taillights	Check operation	–
Seat Latches	Push down on both seat backs to ensure the latches are secure	page 41

SAFETY

ITEM	REMARK	REFERENCE
Seat Belts	Check length of belt for damage, check latches for proper operation	page 46
Exhaust	Inspect spark arrester and clean if needed.	page 122
Vehicle Debris	Remove grass, leaves, and other flammable material or debris, especially near the exhaust system.	-
Passenger Hand Hold	Always adjust the hand hold to a comfortable position for your passenger before operating. Make sure the clasps are fully locked after making adjustments.	-
Lock adjustable steering wheel	Do not adjust the steering wheel while the vehicle is moving.	-

Improper tire maintenance can lead to loss of control and an accident, which could result in serious injury or death. To reduce your risk of injury:

- Maintain POLARIS recommended tire pressure. Check pressure before operating. Even if your vehicle has only been driven a short distance, the tire pressure readings can become higher.
- Make sure tire pressures match the specifications listed in the table below.
- Only use the size and type of tires specified for this vehicle.
- Do not operate your vehicle with worn or damaged tires.
- Always follow your tire manufacturer's instructions for maintenance.

MEASUREMENT	SPECIFICATION	
Model	RZR Turbo R	RZR Turbo R 4
Maximum Cargo Box Load	300 lbs (136 kg)	300 lbs (136 kg)
Tire Pressure in PSI (kPa)	Front: 15 (103) Rear: 15 (103)	Front: 18 (124) Rear: 18 (124)
Maximum Weight Capacity Includes weight of operator, passenger, cargo, and accessories	730 lbs (331 kg)	1160 lbs (526 kg)

PREPARE YOURSELF, PASSENGERS, AND CARGO FOR THE RIDE

Wear an approved helmet. Riding in this vehicle without wearing an approved helmet increases the risk of serious injury. For example, a helmet reduces your risk of injury from head strikes with the vehicle or other objects even if there is no crash.

Approved helmets in the USA and Canada bear a U.S. Department of Transportation (DOT) label. Approved helmets in Europe, Asia, and Oceania bear the ECE 22.05 label. The ECE mark consists of a circle surrounding the letter E, followed by the distinguishing number of the country which has granted approval. The approval number and serial number will also be displayed on the label.



Use shatterproof goggles or a shatterproof helmet face shield. Such protective eyewear may reduce the risk of foreign material getting in your eyes and help prevent loss of vision.

POLARIS recommends wearing approved Personal Protective Equipment (PPE) that have markings indicating they are designed to standards such as:

- VESC 8
- V-8
- Z87.1
- CE



Additional protective clothing and gear that may be appropriate for your riding conditions includes:

- Always wear shoes when operating. Consider wearing sturdy over-the-ankle boots suitable for the terrain you will be riding in.
- Full-finger gloves can protect against wind, sun, cold, and objects. Choose gloves that fit snugly and allow fingers to move freely and grip on the steering wheel or hand holds.
- Consider long sleeves and long pants to help protect arms and legs.
- Long-term exposure to wind and engine noise can cause permanent hearing loss. Properly worn hearing protective devices such as earplugs can help prevent hearing loss. Check local laws or the rules of the riding area you are in before wearing hearing protection to make sure its use is permitted.

Always stay completely inside the vehicle and hold the steering wheel or hand holds. Body parts outside of the vehicle can be struck by passing objects or crushed during a rollover. Do not put any part of your body outside of the vehicle for any reason. Do not hold onto the ROPS frame or put any part of your body on the door.

Riding in this vehicle without closed and latched cab doors increases the risk of serious injury or death in the event of an accident or rollover. Always make sure all cab doors are closed and latched while riding in this vehicle.

Be sure riders pay attention and plan ahead. If you think or feel the vehicle may tip or roll, reduce your risk of injury:

- Keep a firm grip on the steering wheel or hand holds and brace yourself.
- Do not put any part of your body outside of the vehicle for any reason.

This vehicle is not designed to carry unrestrained pets. An unrestrained pet can be thrown about and injure riders, even during normal operation. When transporting pets, use a pet crate suitable for off-road use that is secured to the vehicle.

Fuels such as gasoline can be extremely flammable. To reduce the risk of serious injury or death, never carry fuel or other flammable liquids on this vehicle. Rollovers, crashes, rough riding, or changes in elevation or temperature may lead to fuel spilling or vapor release from portable containers. Hot vehicle parts can cause fires, even after the engine has been turned off.

Never exceed vehicle weight capacities. Overloading the vehicle or carrying cargo improperly will cause changes in stability and handling, which could cause loss of control or an accident. See the Specifications chapter for weight capacities.

Secure cargo in the cargo box as far forward, centered and as low as possible. When cargo cannot be positioned and secured in this way, operate with extra caution. Unsecured cargo can strike and injure riders, affect vehicle handling, and result in loss of control.

The weight of riders and cargo changes vehicle braking, handling, and stability. To avoid loss of control, turn gradually, operate at slower speeds, and avoid rougher or steeper terrain.

DRIVING GUIDELINES

Drive Responsibly. This vehicle has higher ground clearance and other features to handle rugged terrain. It can be overturned in situations where some other vehicles may not. Abrupt maneuvers or aggressive driving, even on flat, open areas, can cause loss of control, rollovers, severe injury or death. To avoid loss of control and rollovers:



- Avoid abrupt maneuvers, sideways sliding, skidding, or fishtailing, and never do donuts.
- Slow down before entering turn.
- Avoid hard acceleration when turning, even from a stop.

High speed off-road operation

Driving off-road vehicles to test the limits of your skills or abilities can be very dangerous to you, passengers, and bystanders. Basic skills for driving a car, ATV, or other off-road vehicles do not equip drivers to safely attempt high speed off-road operation. Develop your skill gradually through training, practice, and experience with the various driving modes of this vehicle and the terrain in which you are operating. Always do a low speed reconnaissance run (prerun) to become aware of anything you may encounter.

High speed off-road operation can lead to loss of control, crashes, or hard landings that can seriously injure occupants (even without rolling the vehicle or damaging it).

If you plan on using the vehicle for high speed, off-road competition, additional safety equipment may be necessary. Check the rules that apply to your competition.

Do not go over jumps — going airborne can lead to serious injury or death.

Going airborne can cause loss of control, rollovers, or crashing into the ground and may damage the vehicle. Even without crashing, landings can be hard enough to cause any vehicle suspension to fully compress (e.g., bottom out). Serious injuries, including spinal injuries, can occur even if riders are properly harnessed, wearing helmets and the vehicle is not damaged and remains upright.

You may encounter slopes, "jumps", or other terrain features that could send the vehicle airborne, depending on your speed. These may be defectively designed, poorly maintained, or not suitable for this vehicle. Slow down, use extra care, and avoid going airborne. Never take this vehicle over jumps.

Watching someone else go over a jump or go airborne does not mean you can safely do so. Polaris cannot determine whether any jump you may encounter is appropriate for this vehicle. Any jump, even a small one, could be poorly maintained, designed, or not suitable for this vehicle and may cause serious injury or death.



Plan for hills, rough terrain, ruts, and other changes in traction and terrain.

Proceed slowly and with extra care on unfamiliar terrain. Avoid paved surfaces. Sudden changes in terrain such as holes, depressions, banks, softer or harder ground, or other irregularities may cause loss of control or rollover. Give yourself time to react to rocks, bumps, or holes that may be hard to see. Operating in deep snow or tall grass may make it harder to see obstacles.

If you cannot go around an obstacle, such as a fallen tree or a ditch, stop the vehicle in a safe place. Get out to inspect the area thoroughly. Look from both your approach side and exit side. If you are reasonably confident you can continue safely, choose the path that will allow you to go straight over the obstacle to minimize the vehicle tipping sideways. Go only fast enough to maintain your momentum, but still give yourself plenty of time to react to changes in conditions. If there is any question about your ability to maneuver safely over the obstacle, you should turn around if the ground is flat and you have the room, or back up until you find a less difficult path.

Abrupt application of the accelerator pedal can cause the tires to lose traction, reducing control of the vehicle and increasing the possibility of an accident, especially while on sloped terrain or while crossing obstacles such as rocks or logs.

Avoid Operating on Public Roads (Paved or Otherwise). This vehicle does not have highway safety features that on-road vehicles may have (air bags, anti-lock brakes, stability control, etc.). If another vehicle collides with you, the likelihood of a serious injury or death may be greater. Also, you may not be able to avoid a crash or rollover if you make sudden or abrupt maneuvers such as swerving or emergency braking.

While it may be legal locally to drive on some public roads in specific parts of the country, your vehicle was not designed or certified as an on-road motor vehicle. Polaris does not support public road use except as may be necessary to cross-roads designated for connecting off highway vehicle trail segments. If you must drive on-road, drive slowly and defensively. Your vehicle may lack the features needed to comply with state or local laws that permit limited public road use. Modifications you make to your vehicle to meet these requirements may void the vehicle warranty. In addition, refer to tire manufacturer's instructions or limitations for on-road operation, including speed limits and premature tire wear.

SAFETY

Improperly operating on hills can cause loss of control, rollover, or accident, which can lead to serious injury or death. Use extra care when operating on hills. Plan for rough terrain, ruts, and other changes in traction and terrain.

Driving up hills

Check the terrain before ascending a hill and make sure it is not too slippery or loose. Engage all-wheel drive for hills. Drive straight uphill, keeping speed and throttle steady. Avoid steep hills which can cause the vehicle to overturn.

Recovering from stalling on a hill

If the vehicle loses forward speed, apply the brakes gradually and stop. Do not attempt to turn the vehicle around. Instead, shift to reverse and allow the vehicle to slowly roll straight downhill. Apply light brake pressure to control speed.

Overtopping a hill

Slow down when you reach the crest of a hill. Never blindly go over the crest of a hill or a drop off at high speed. An obstacle, a sharp drop, or another vehicle or person could be on the other side of the hill.

Driving down hills

Check the terrain before descending a hill and make sure it is not too slippery or loose. Engage all-wheel drive and proceed slowly, applying the brakes lightly. Never descend a hill with the transmission in neutral or if the engine is turned off.

Avoid side hilling (riding across slopes)

If unavoidable, proceed slowly and with extra caution. Avoid obstacles and changes in terrain that could cause the vehicle to tip or slide. If it feels like the vehicle begins to tip or slide, immediately turn downhill.

Riding near wooded areas or brush

Use extra caution when operating near trees, particularly when operating on narrow trails. Tree branches or brush can be driven into the cab striking or stabbing occupants.



Riding in snow

Always keep the brake and accelerator pedals free of snow and ice. Apply the brakes frequently to prevent ice or snow accumulation on the brake pads which can reduce brake performance.

Riding on ice

Never operate the vehicle on a frozen body of water unless you have verified that the ice can support the weight of the vehicle. Severe injury or death can result if the vehicle falls through the ice.

Riding in water / Falling into water

Operating through deep or fast-flowing water can cause loss of traction, loss of control, overturning, or being swept away in water. You can be seriously injured or killed from entrapment and drowning. Never operate the vehicle in fast-flowing water or in water that exceeds the floor level of the vehicle. Avoid sharp drop-offs and large rocks. Choose a path that provides an entrance and exit point with gradual inclines. Wet brakes may have reduced stopping ability. After leaving water, test the brakes. Apply them lightly several times while driving slowly. The friction will help dry out the pads.

Riding on sand dunes

Use extra caution when operating on or near dunes. Be alert for changes in terrain. Never blindly go over the crest of a hill or a drop-off at high speed. An obstacle, a sharp drop, or another vehicle or a person could be on the other side of the hill.

Riding in low-visibility conditions

Use extra caution and drive slowly in conditions of reduced visibility such as fog, rain, and darkness.

Plan ahead to avoid the need for evasive maneuvers, such as swerving.

Hitting an obstacle — including wildlife — you are not ready for can be dangerous. Choosing to swerve instead can be even more dangerous because it can lead to loss of control, rollover, or collisions.

When operating in areas with possibility of wildlife appearing in your path, plan ahead to avoid swerving for animals if doing so could result in collisions or rollovers. Go slowly or avoid driving during seasons or times of day when animals such as deer are more likely to cross your path without warning.

SAFETY

Avoid Collisions With Other Vehicles

When following another vehicle or operating in the same area as others, keep a safe distance to avoid collisions. Allow extra space when sight distances are limited by dust, snow, curves, hills, or other conditions. Plan ahead to avoid having to swerve or leave the trail to avoid a collision.

On trails, be prepared to make space for other vehicles to pass. If you need to stop on a trail, move your vehicle to the edge of the path to allow others to pass safely.

Correct a skid by turning the steering wheel in the direction of the skid.

Never apply the brakes during a skid.

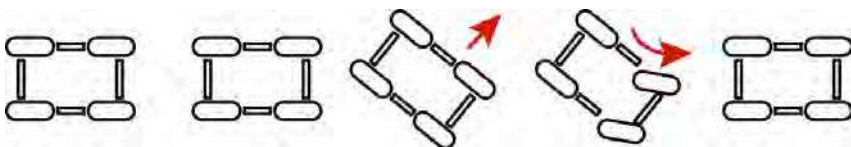

If the vehicle begins to slide downhill or you feel it may tip, turn downhill immediately and stop. Maneuver slowly and carefully until you can drive straight downhill.

Do not continue driving if your vehicle may be damaged or if you were in a crash or rollover.

Operating the vehicle while damaged or after a crash or rollover can cause loss of control, rollover, or accident, which can lead to serious injury or death. If you cannot safely transport the vehicle on your own, contact a recovery and towing service.

After any crash, rollover, or other accident, have a POLARIS dealer inspect the vehicle for possible damage, including seat belts, ROPS, brakes, suspension, and steering systems.

Be prepared in case your vehicle becomes damaged or disabled, especially in remote areas. Consider in advance how to get help and stay safe until it arrives whenever you ride.

The vehicle does not have a tow hitch and is not designed to tow another vehicle for any distance.

Towing can alter vehicle handling and may cause loss of control.

There is a recovery tow loop at the front and back of the vehicle to attach a winch or strap.

Use these loops to recover this vehicle if it is stuck, to pull it onto a tow truck, trailer, or to use this vehicle to recover another vehicle. These loops are for emergency recovery only and are not for towing vehicles to another location.

Improper recovery may lead to loss of control or vehicle damage. Only attach straps to specified locations. Do not attach to any other point on the vehicle. Only recover a vehicle of equal or lesser size and weight. When recovering a disabled vehicle, place the disabled vehicle's transmission in neutral. Do not move a disabled RZR faster than 10 mph (16 km/h).

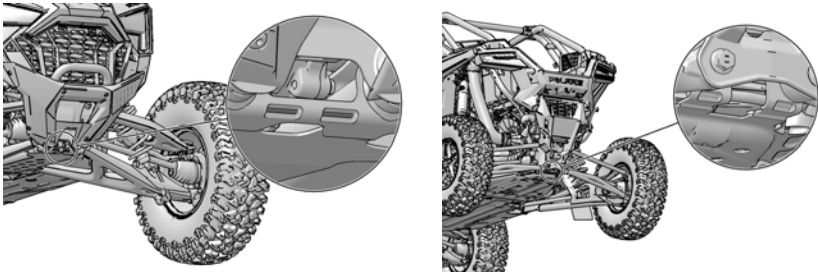
**Operating, Idling, Or Parking Near Combustible Materials**

Engine, exhaust, and other vehicle components can be very hot during and after use. Do not idle or park the vehicle over anything that could contact the exhaust system and catch on fire, such as tall grass, weeds, brush, leaves, debris, or other tall ground cover. Do not let mud, grass, or other debris accumulate on the engine or exhaust system. Inspect and remove as needed.

Vehicle rollaway can cause serious injury or death. This vehicle can roll whenever the gear selector is not in the PARK (P) position. Always shift to PARK (P) when stopping the engine or leaving the vehicle. When leaving the vehicle on an incline is unavoidable, use extra care. If leaving the vehicle unattended, block the rear wheels on the downhill side and keep children, pets, and others away from the gear selector.

Before shifting into reverse, use extra care to make sure the area is clear of people or obstacles. When it's safe to proceed, back slowly.

SAFETY

After operation, inspect the vehicle for damage and debris to make sure the vehicle can be safely stored and operated again. Some things to inspect include:

- Debris that could catch fire, such as mud/grass near the engine or exhaust system
- Damage to the suspension, steering, or any other part of the vehicle
- Tire condition, such as tread and sidewall damage
- Shock absorber assembly condition

Be sure to have any issues checked and problems fixed before operating again.

All engine exhaust contains carbon monoxide, a deadly gas. Breathing carbon monoxide can cause headaches, dizziness, drowsiness, nausea, confusion, and eventually death. Carbon monoxide is a colorless, odorless, tasteless gas which may be present even if you do not see or smell any engine exhaust. Deadly levels of carbon monoxide can collect rapidly, and you can quickly be overcome and unable to save yourself. Also, deadly levels of carbon monoxide can linger for hours or days in enclosed or poorly ventilated areas. If you experience any symptoms of carbon monoxide poisoning, leave the area immediately, get fresh air, and **SEEK MEDICAL TREATMENT**.

- Do not run engine indoors. Even if you try to ventilate engine exhaust with fans or open windows and doors, carbon monoxide can rapidly reach dangerous levels.
- Do not run engine in poorly ventilated or partially enclosed areas such as barns, garages, or carports. If you start a vehicle in one of these, drive it out and close the door as soon as possible. If you drive it into one of these, turn it off as soon as possible.
- Do not run engine outdoors where engine exhaust can be drawn into a building through openings such as windows and doors.

SAFETY LABELS AND LOCATIONS

Warning labels have been placed on the vehicle for your protection. Read and follow the instructions of the labels on the vehicle carefully. If any of the labels depicted in this manual differ from the labels on your vehicle, always read and follow the instructions of the labels on the vehicle.

Never remove any labels from your vehicle. If an informational or graphic label becomes illegible or comes off, contact your POLARIS dealer to purchase a replacement. Replacement safety labels are provided by POLARIS at no charge. The part number is printed on the label.

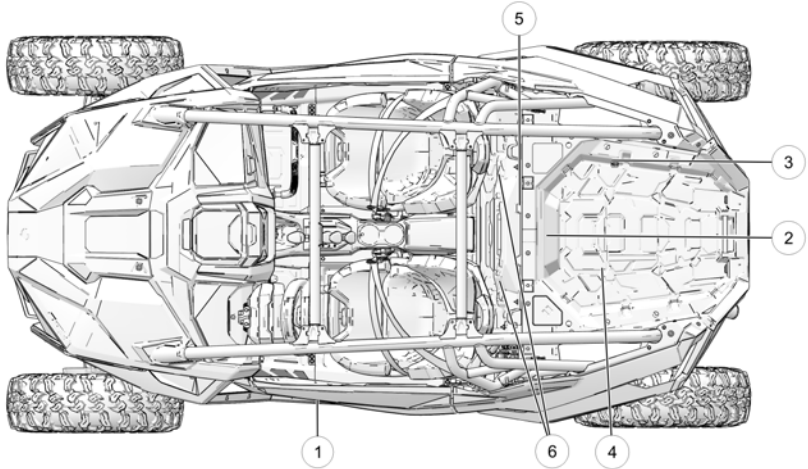

① Driver Information Warning

④ Belt Debris Warning (On Clutch Cover)

② Tire Pressure Warning

⑤ Air Box Caution (On Air Box)

③ Fuel Transport Warning

⑥ Rear Seat Warning (Turbo R 4 Only)

SAFETY

DRIVER INFORMATION WARNING (TURBO R)

WARNING

FOLLOW ALL INSTRUCTIONS AND WARNINGS.

Improper vehicle use can result in SEVERE INJURY or DEATH.

Be Prepared

- Fasten seat belts.
- Wear an approved helmet and protective gear.
- **ALWAYS** use cab nets and/or doors.
- Each rider must be able to sit with back against seat, feet flat on the floor, and hands on steering wheel or hand holds. Stay completely inside the vehicle.

Drive Responsibly

Avoid loss of control and rollovers:

- Avoid abrupt maneuvers, sideways sliding, skidding or fishtailing, and never do donuts.
- Slow down before entering a turn.
- Avoid hard acceleration when turning, even from a stop.
- Plan for hills, rough terrain, ruts and other changes in traction and terrain. Avoid paved surfaces.
- Avoid sidehilling (riding across slopes).

Rollovers have caused severe injuries and death, even on flat, open areas.

Require Proper Use of Your Vehicle

Do your part to prevent injuries:

- Do not allow careless or reckless driving.
- Make sure operators are 16 or older with a valid driver's license.
- Do not let people drive or ride after using alcohol or drugs.
- Do not allow operation on public roads (unless designated for off-highway vehicle access) - collisions with cars and trucks can occur.
- Do not exceed seating capacity: 1 passenger.

Be Sure Riders Pay Attention and Plan Ahead

If you think or feel the vehicle may tip or roll, reduce your risk of injury:

- Keep a firm grip on the steering wheel or hand holds and brace yourself.
- Do not put any part of your body outside of the vehicle for any reason.

Part Number: 7300045

DRIVER INFORMATION WARNING (TURBO R 4)

WARNING

FOLLOW ALL INSTRUCTIONS AND WARNINGS.

Improper vehicle use can result in SEVERE INJURY or DEATH.

Be Prepared

- Fasten seat belts.
- Wear an approved helmet and protective gear.
- **ALWAYS** use cab nets and/or doors.
- Each rider must be able to sit with back against seat, feet flat on the floor, and hands on steering wheel or hand holds. Stay completely inside the vehicle.

Drive Responsibly

Rollovers have caused severe injuries and death, even on flat, open areas.

Avoid loss of control and rollovers:

- Avoid abrupt maneuvers, sideways sliding, skidding or fishtailing, and never do donuts.
- Slow down before entering a turn.
- Avoid hard acceleration when turning, even from a stop.
- Plan for hills, rough terrain, ruts and other changes in traction and terrain.
- Avoid paved surfaces.
- Avoid sidehilling (riding across slopes).

Require Proper Use of Your Vehicle

Do your part to prevent injuries:

- Do not allow careless or reckless driving.
- Make sure operators are 16 or older with a valid driver's license.
- Do not let people drive or ride after using alcohol or drugs.
- Do not allow operation on public roads (unless designated for off-highway vehicle access) - collisions with cars and trucks can occur.
- Do not exceed seating capacity: 3 passenger.

Be Sure Riders Pay Attention and Plan Ahead

If you think or feel the vehicle may tip or roll, reduce your risk of injury:

- Keep a firm grip on the steering wheel or hand holds and brace yourself.
- Do not put any part of your body outside of the vehicle for any reason.

Part Number: 7300166

SAFETY

FUEL TRANSPORT WARNING

NEVER carry fuel or other flammable liquids on this vehicle.
Failure to follow this instruction could lead to serious burn injuries or death.



REAR SEAT WARNING

WARNING

Do not ride in rear cabin area when seat back or seat base is not installed in riding position.

Part Number: 7300168

AIR BOX CAUTION

CAUTION:

Use a Polaris approved air filter. The use of a non-Polaris approved air filter may cause engine damage. Before installing filter, ensure there is no dirt or debris in the clean side of the intake tube. The air filter must be properly seated before the lid is reinstalled. Please reference your owner's manual for additional information regarding air filter service.

① Air Box Caution

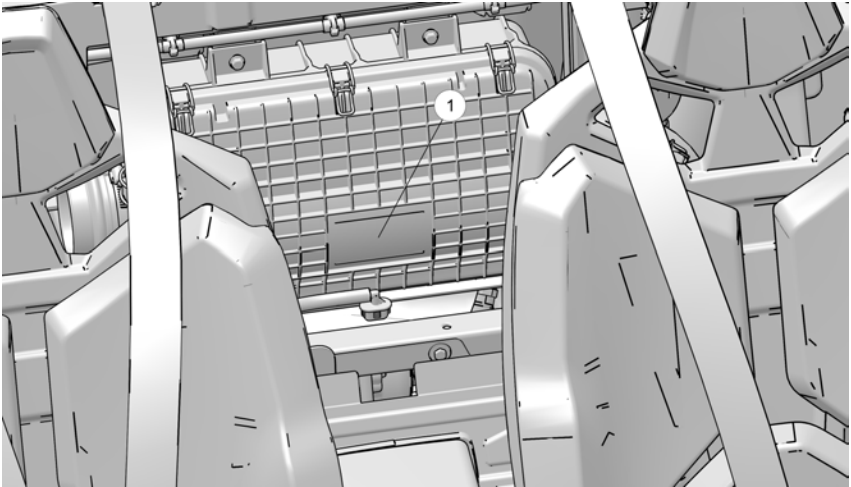

SAFETY

BELT DEBRIS WARNING

- Improper service or maintenance of this PVT system can result in vehicle damage, SEVERE INJURY or DEATH.
- Always look for and remove debris inside and around the clutch and vent system when replacing the belt.
- Read owner's manual or see authorized dealer.

① Belt Debris Warning

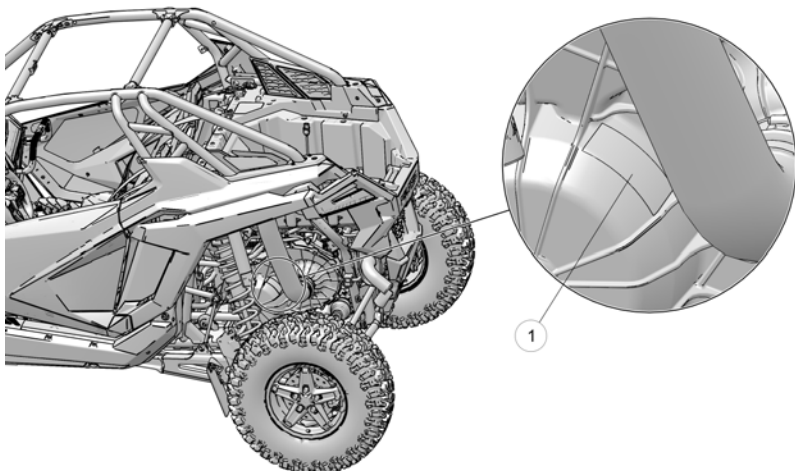

LOAD / PASSENGER / TIRE PRESSURE WARNING

The Load / Passenger / Tire Pressure Warning ① is located at the rear of the vehicle in the cargo box.

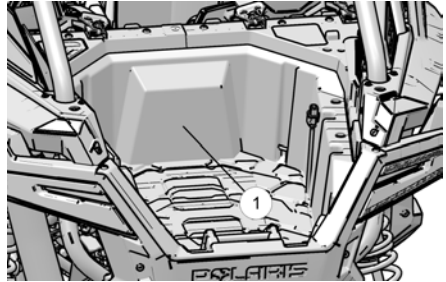

- Never carry passengers in cargo box.
- Passengers can be thrown off. This can cause serious injury or death.

IMPROPER TIRE PRESSURE OR OVERLOADING CAN CAUSE LOSS OF CONTROL RESULTING IN SERIOUS INJURY OR DEATH.

- Reduce speed and allow greater distance for braking when carrying cargo.
- Overloading or carrying tall, off-center, or unsecured loads will increase your risk of losing control. Loads should be centered and carried as low as possible in box.
- For stability on rough or hilly terrain, reduce speed and cargo.

	TURBO R	TURBO R 4 SEAT
MAXIMUM CARGO BOX LOAD	300 lbs. (136 kg)	
TIRE PRESSURE IN PSI (KPa)	FRONT 15 (103) REAR 15 (103)	FRONT 18 (124) REAR 18 (124)
MAXIMUM WEIGHT CAPACITY INCLUDES WEIGHT OF OPERATOR, PASSENGERS, CARGO AND ACCESSORIES	730 lbs. (331 kg)	1160 lbs. (526 kg)
Read Operation and Maintenance Manual for more detailed loading information.		

FEATURES AND CONTROLS

NEAR-FIELD COMMUNICATION (NFC) (IF EQUIPPED)

Some Polaris vehicles come equipped with a near-field communication (NFC) chip. The NFC chip is embedded in the Polaris emblem located at the front of the vehicle and seamlessly connects you to a digital platform of vehicle information and tools. See your dealer for more information.

IMPORTANT

Not all devices are equipped with an NFC reader. Additionally, some devices require third party applications to access NFC content. For questions regarding the NFC reader on your device, refer to the device's user manual.

On models equipped with NFC, place your smartphone directly over the Polaris emblem to do the following:

- View vehicle-specific information
- Access your Polaris Garage
- Download and view the owner's manual
- View accessory instructions
- Watch how-to videos
- Access warranty information
- Check for service notifications



RIDE COMMAND WITH NFC

Additional NFC features are available when using the Ride Command mobile app. To access these features, do the following:

1. Download the Ride Command mobile app from the Apple App Store® or Google Play® store.
2. Create or log in to an existing account.
3. From the Ride Command mobile app home screen, select **Add Vehicle**.
4. On the vehicle, tap the NFC-enabled badge with the phone to scan the vehicle.
5. Confirm information, name your vehicle, and tap add to garage.

SYSTEM REQUIREMENTS

Refer to device manufacturer's instructions to verify NFC read capability, and/or NFC-capable add-ons.

COMPONENT LOCATIONS

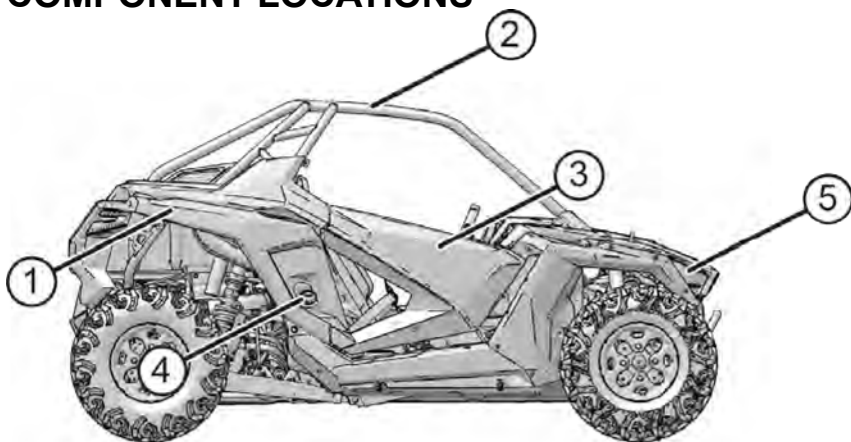

- ① Cargo Box
- ② ROPS Frame
- ③ Cab Door
- ④ Fuel Tank Cap
- ⑤ Radiators

STANDARD STEERING WHEEL (IF EQUIPPED)

The steering wheel can be tilted upward or downward for rider preference. Lift and hold the steering wheel adjustment lever ① while moving the steering wheel upward or downward. Release the lever when the steering wheel is at the desired position.

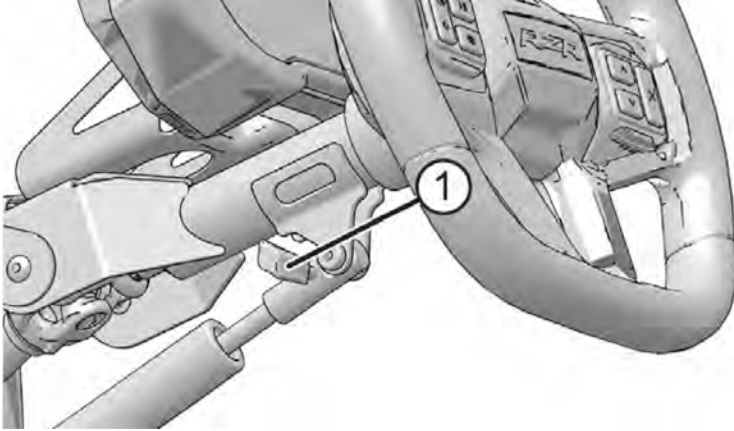

TELESCOPE STEERING WHEEL (IF EQUIPPED)

The telescoping steering wheel can be adjusted by pressing the release lever ① downward. Once released, the steering wheel can be tilted up/down and telescoped in/out freely. When desired position is found, hold the steering wheel in place with one hand and pull the release lever back up with the other. The release lever will catch into place when it is locked.

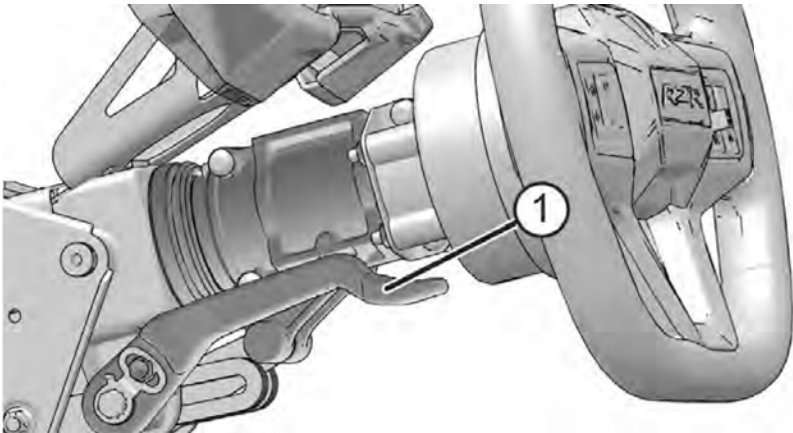

STEERING WHEEL CONTROLS

RIDE MODE CONTROLS (IF EQUIPPED)

If equipped, Ride Mode controls can be found on the right-hand side of the steering wheel. There are 4 available modes to select from: Baja, Rock, Track, and Comfort. The UP and DOWN arrow buttons are used to cycle through the different modes.

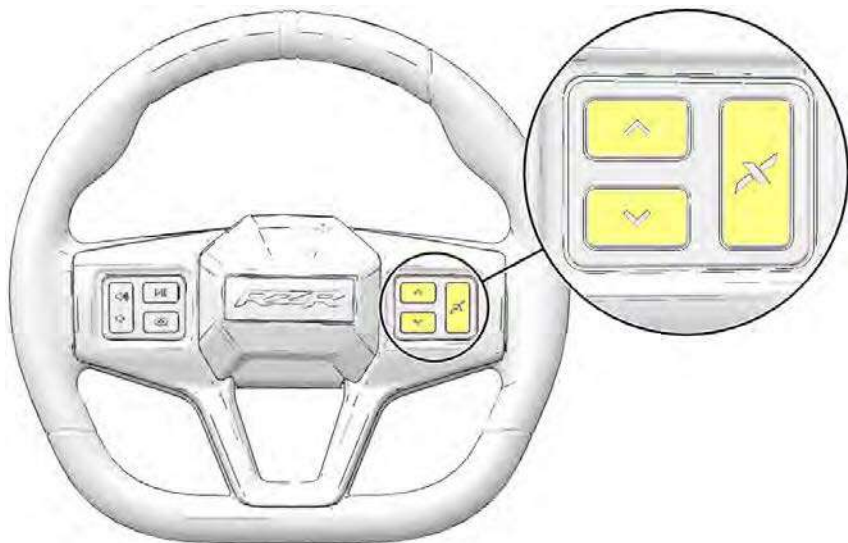

The momentary MAX FIRM button is on the right. When this button is pressed, the suspension will immediately switch to maximum compression damping. The vehicle will maintain this setting if the button is continuously pressed. Once the button is released, maximum compression damping will persist temporarily, and then revert back to the previous setting.

NOTICE

The system will prevent mode transitions when a current vehicle state is present (cornering, braking, or accelerating).

FEATURES AND CONTROLS

MODE	SUSPENSION DESCRIPTION	POWER STEERING DESCRIPTION
Baja Mode	High compression and low rebound damping for large and aggressive suspension events.	Good feeling of the front wheels with excellent bump rejection.
Rock Mode	High compression and low rebound with angle based damping adjustments for maneuvering through rockier terrain. At higher vehicle speeds, damping becomes similar to Comfort Mode.	High assist level and bump rejection for low steering effort when maneuvering in rocks.
Track Mode	Medium compression and high rebound damping for frequent cornering events.	Best feeling of the front wheels for frequent cornering events.
Comfort Mode	Low compression and rebound damping to allow the shock to move and absorb smaller suspension events.	High assist level and bump rejection for low steering effort and maximum comfort.
"Demo" Mode	"Demo" Mode allows the operator to experience the feel associated with each Ride Mode before actual use. Activate "Demo" Mode by placing the vehicle in Park (P) and turning off the engine, then turn the ignition key switch to ON position. The operator can cycle through the different Ride Modes using the UP or DOWN arrow buttons, then use the throttle, brakes, and steering wheel to assess the feel of each Ride Mode.	

FEATURES AND CONTROLS

AUDIO CONTROLS (IF EQUIPPED)

If equipped, audio controls can be found on the left-hand side of the steering wheel. Volume can be adjusted by pressing the bottom (lower volume) or the top (higher volume) of the button.

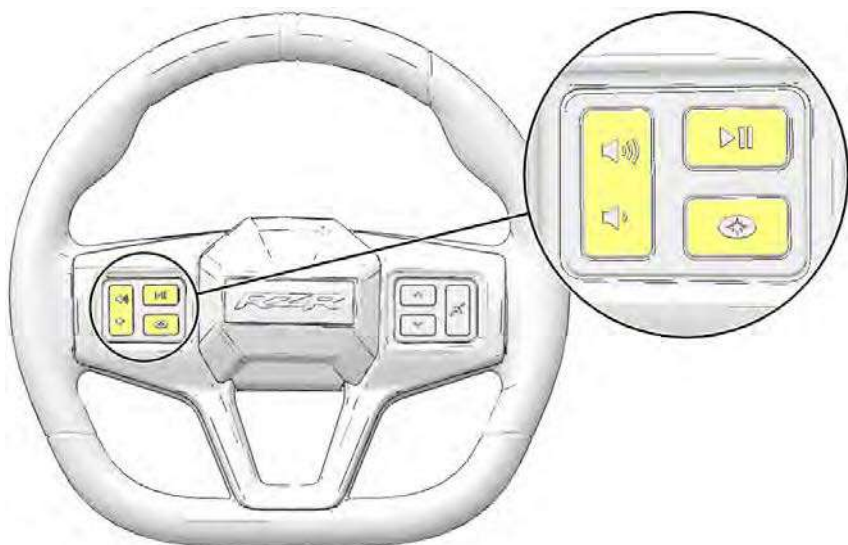

Audio can be paused or resumed by pressing the pause button.

Refer to the Ride Command manual for operating the third Polaris button.

SWITCHES

IGNITION SWITCH

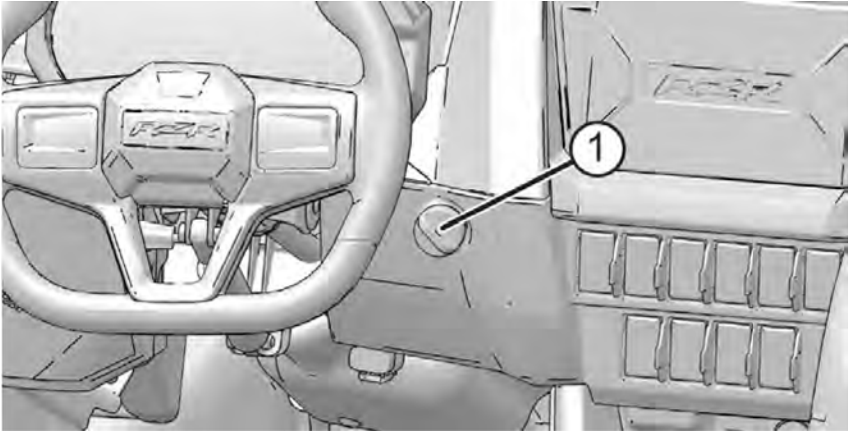

The ignition switch ① is a four-position, key-operated switch. Use the ignition switch to start the engine. See the Starting the Engine section for starting procedures.

POSITION	FUNCTION
OFF	The engine is off. Electrical circuits are off, except accessory 12V.
ACCESSORY	The engine is off. Powers the display, terminal block, and front/rear accent lights. Check engine and power steering warning indicators will appear on the display in this mode but will turn off when the vehicle is started if no issues are present.
ON	Electrical circuits are on. Electrical equipment can be used.
START	The vehicle must be in PARK or NEUTRAL before the engine can start. To start the vehicle, press the brake pedal, turn the key to the start position, and then release. The engine will turn over for about 5 seconds or until started.

The key can be removed from the switch when it is in the OFF position.

FEATURES AND CONTROLS

HEADLIGHT SWITCH

The ignition switch key must be in the ON/RUN position to operate the headlights. The headlight switch is a toggle and has three positions:

UP – High Beam

CENTER – Low Beam

DOWN – Headlights Off



DRIVELINE MODE (AWD) SWITCH

The ignition switch key must be in the ON/RUN position to operate the Driveline Mode system. The Driveline Mode switch is a toggle and has two positions:

UP – All Wheel Drive (AWD)

CENTER – Two Wheel Drive (2WD)

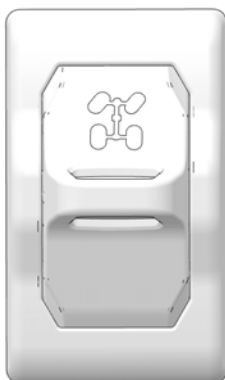

AUXILIARY OUTLETS

⚠ WARNING

To avoid electric shock, do not touch power outlets with wet hands or insert any object that the power outlet is not designed to receive. Close the lid when not in use.

NOTICE

The front console accessory outlet is always active. The accessory outlet in the armrest storage bin is only active when the ignition switch is set to ON.

The vehicle is equipped with two 12-volt accessory outlets. One is in the front portion of the center console, in front of the gear selector. The other is in the armrest storage bin. Use the outlets to power an auxiliary light or other optional accessories.



ELECTRONIC POWER STEERING (EPS)

Electronic power steering engages when the ignition key is turned to the ON position. EPS remains engaged whether the vehicle is moving or idle.

The EPS warning indicator briefly illuminates when the key is turned to the ON position. See the Indicator Lamps section for details.

If the engine is off but the ignition switch remains in the ON position, the EPS will shut down after 5 minutes of engine inactivity. The EPS warning indicator will illuminate to indicate the EPS has shut down.

NOTE
The EPS shuts down automatically to conserve the battery power of your vehicle.

If the EPS warning indicator remains on after turning the ignition switch to OFF and then starting the engine, the EPS system is inoperative. See your POLARIS dealer, or another qualified person, as soon as possible for repair. Continued operation could result in permanent damage to the EPS unit and increased steering effort.

SEATS



Prolonged sun exposure can cause excessive heating of the steering wheel and seats. Use caution when handling hot surfaces to avoid burns.

Before operating the vehicle, always push down on all seat backs to ensure the latches are secure.

SEAT REMOVAL

To adjust the seat, do the following:

1. Pull up on the seat latch lever ① located under the front edge of the seat.
2. Tilt the seat forward.
3. Lift the seat upward to remove it from the vehicle.

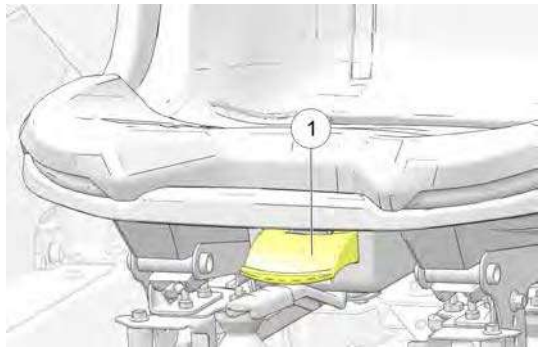

4. Reverse this procedure to reinstall the seat. Make sure the seat tabs at the front edge of the seat slide onto the seat retainer tubes.
5. Press down firmly at the rear of the seat to engage the rear latches.

SEAT ADJUSTMENTS

DRIVER'S SEAT ADJUSTMENT

On seats equipped with an adjustment lever ① under the front edge of the seat, pull the lever to the left. Slide the seat forward or rearward to the desired position. Release the lever. The seat will lock into the new position.

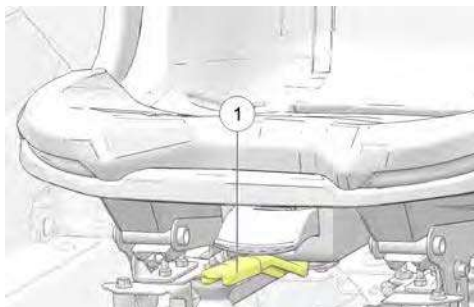

To adjust seat tilt, adjustment bolts can be removed and re-installed at a different tilt setting. The driver side has two adjustment bolts ②, one on each side, and has three tilt hole options. Re-install the bolts to specification when finished with adjustments.

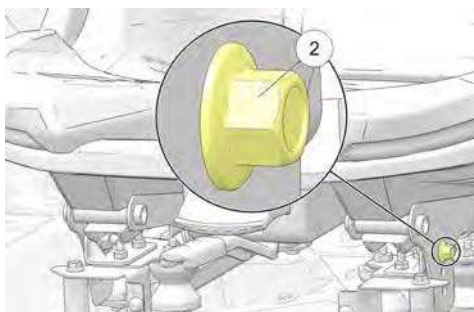

TORQUE

Seat Adjustment Bolts:
15 ft-lbs (20 N·m)

PASSENGER SEAT ADJUSTMENT

To adjust the passenger seat position, remove the seat and remove the four bolts ③ located on the two seat frame members. The seat frame members can be moved forward (or backward) to the desired position.

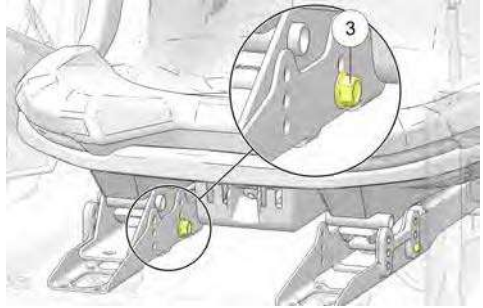

The passenger seat can also be tilted up/down (similar to the driver seat) using the three tilt hole options. Choosing which set of tilt holes to use is dependent on whether the seat position has been moved forward or backward. Re-install the bolts to 15 ft-lbs (20 N·m) of torque when finished with adjustments.

TORQUE

Seat Adjustment Bolts:
15 ft-lbs (20 N·m)

PASSENGER HAND HOLD

Always adjust the hand hold to a comfortable position for your passenger before operating. Make sure the clasps ① are fully locked after making adjustments.

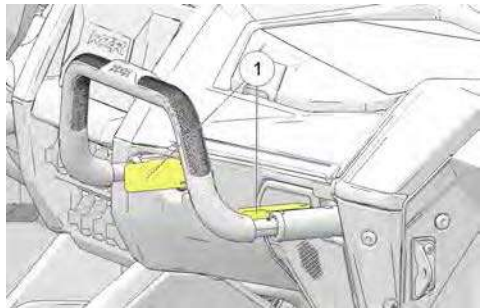

To adjust the passenger hand hold, do the following:

1. Unlock the two passenger hand hold clasps ①.
2. Pull or Push the bar to desired position.
3. Lock both clasps back into place.

FEATURES AND CONTROLS

FUEL LEVEL

The fuel tank filler cap ① is located on the right side of the vehicle near the passenger seat.

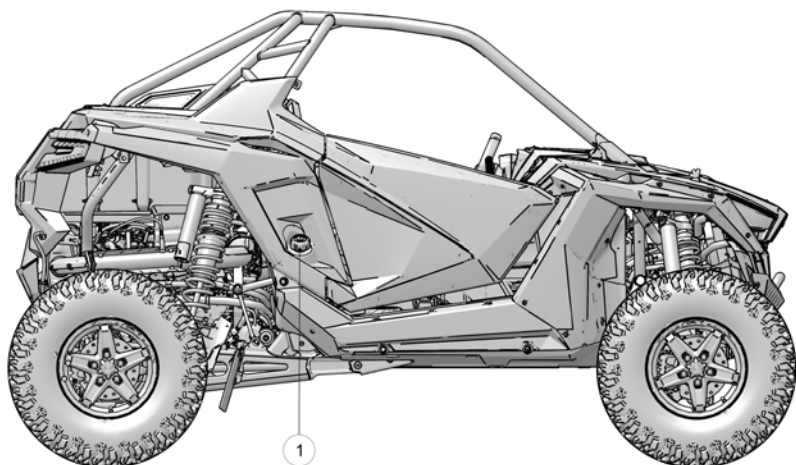

The fuel symbol and the last fuel bar on the MFD gauge will blink when the fuel level reaches 1/8th tank. There will be approximately one gallon of fuel remaining. Refuel as soon as possible. *Do not allow the vehicle to run out of fuel.*

NOTICE

Damage to the fuel pump will occur if the vehicle is operated with an empty fuel tank. Do not allow the vehicle to run out of fuel. Always refuel when the level is low.

NOTICE

Operating with obstructed fuel systems will result in serious engine damage. Perform maintenance as recommended.

NOTICE

Prolonged exposure to petroleum based products may damage paint. Always protect painted surfaces when handling fuel.

FUEL RECOMMENDATIONS

- Use ONLY 91 octane (or higher) unleaded fuel (minimum pump octane number of 91 R+M/2)
- Do not use any fuel lower than 91 octane
- Do not use fuel containing more than 10% ethanol (including E85)

FEATURES AND CONTROLS

SEAT BELTS

This POLARIS vehicle is equipped with seat belts for all riders. Always make sure the seat belts are secured for the operator and all passengers before riding. The driver's seat belt is equipped with a seat belt interlock. Vehicle speed will be limited to 15 mph (24 km/h) if the seat belt is not secured.

MULTI-POINT SEAT BELT

This vehicle is equipped with an IMMI safety harness with built-in interlock. The safety harness requires proper adjustment for each rider and will need to be adjusted when riders change seats.

WARNING

Improper use or adjustment of the harness can cause serious injury or death. For example, you can slide under the harness in an accident if the lap belt portion of the harness is not pressed against the pelvic bones. Always adjust the harness for each rider to make sure it fits them.

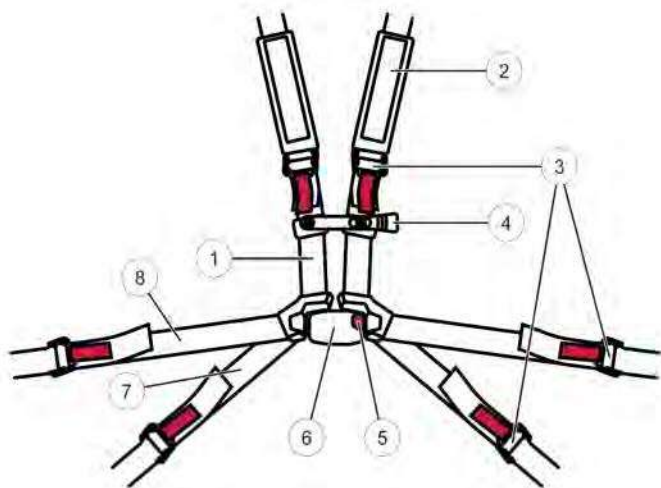

- | | |
|-----------------|-------------------------|
| ① Shoulder Belt | ⑤ Buckle Release Button |
| ② Harness Pads | ⑥ Harness Buckle |
| ③ Tilt-locks | ⑦ Thigh Belt |
| ④ Chest Clip | ⑧ Lap Belt |

INSPECTING THE HARNESS

WARNING

Failure to perform regular inspection can reduce the effectiveness of the seat belt during a crash and could result in serious injury or death.

Before each ride, perform the following inspection:

1. Inspect belt fabric on entire system for cuts, fraying, extreme or unusual wear. Most common areas of belt wear include the buckle/ tongue area, the shoulder guide area and any place where the belt makes contact with vehicle or seat.

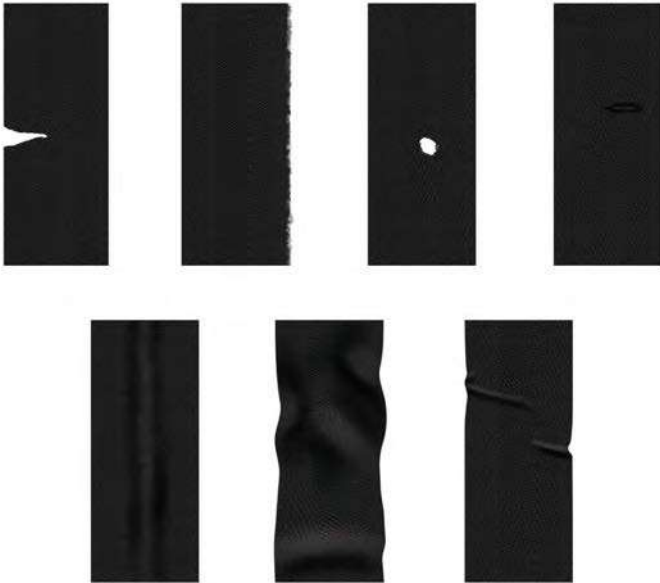

Corrective Action: Replace entire belt system

2. Inspect buckle for proper operation by inserting tongue and listening for an audible click. Verify buckle is not damaged, cracked or broken.

Corrective Action: Replace entire belt system

3. Inspect electrical wires (optional component). Internal cable wires must not be exposed, frayed or broken.

Corrective Action: Replace entire belt system

FEATURES AND CONTROLS

4. Inspect tongue for proper operation by inserting into buckle. Tongue must insert smoothly and you must hear an audible click. Verify proper latching by tugging on belt. Tongue must not be worn, deformed or corroded.

Corrective Action: Replace entire belt system

5. Inspect shoulder web guide. Seat belt must move freely through shoulder web guide. Shoulder web guides must be free of obstructions and must not snag or wear webbing fabric.

Corrective Action: Adjust shoulder web guide hardware and/or remove obstruction.

6. Inspect retractor operation (if equipped). When pulled and released slowly, seat belt must spool out and retract without locking.

Corrective Action: Replace entire belt system

7. Inspect mounting hardware on all belt system attachment points. Hardware should be tight. Hardware must not be missing, rusted, corroded or damaged.

Corrective Action: Replace defective or missing hardware with authorized parts and or tighten hardware.

8. If a harness is used to restrain a rider during an accident, that entire harness system must be replaced. Inspect non-retractable harness pads containing controlled deceleration technology for evidence of a blown fuse (e.g., exposed threading).

Corrective Action: Replace entire belt system

PUTTING ON THE HARNESS

To prepare the rider:

1. Do not wear heavy clothing that may interfere with proper fit of the harness. Make sure there are no rigid or breakable items (e.g., eye glasses, pens, jewelry, keys) under the harness.
2. Before entering the vehicle, your helmet should be off, but accessible from the seat.
3. Adjust the seat to the desired position.
4. Unbuckle the harness and loosen all manually adjustable belts:
 - Lap belts
 - Thigh belts (equipped on 6-pt harnesses)
 - Shoulder belts (not adjustable on retractable 6-pt harness)

How to use the red straps and tilt-lock feature to tighten and loosen the belts:

When the tilt-lock is down ①, the belt resists being tightened or loosened. The red straps are provided so that you can lift the tilt-lock to the up position ② and unlock it so that you can pull the seat belt through. To tighten or loosen a belt, grasp the red strap and pull up on the red strap in one hand and pull the belt with the other. Adjust the angle of the tilt-lock until the belt pulls more easily.

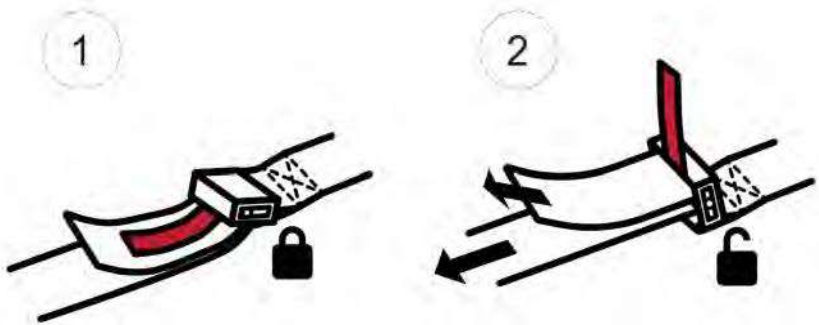

- ① Down, locked position
- ② Up, unlocked position

FEATURES AND CONTROLS

To adjust the harness:

1. Put your arms through the shoulder belts. The belts should lay flat and not be twisted. The shoulder belt should not rub against your neck or fall off your shoulder.

2. Buckle the harness and check the fit of the lap belt. It should be as short as possible and pressed against your pelvic bones so that you cannot lift yourself from the seat bottom at all. Unbuckle and tighten the lap belts as needed until the seat belt is properly adjusted – it is easier to adjust the belts while unbuckled. Finally, buckle the harness and listen for a click. Check fit and make sure buckle is secure.



3. Tighten shoulder belts. If your harness is equipped with non-retracting, adjustable shoulder belts, tighten the shoulder belts until they are snug across your chest when your back is against the seat. When tightening the shoulder belts, be sure to keep the harness buckle centered and below your belly button. The lap belt must remain pressed against your pelvic bones.



4. Tighten thigh belts. If your harness is equipped with thigh belts, adjust them for comfort and be sure to keep the harness buckle centered and below your belly button. The lap belt must remain pressed against your pelvic bones.

5. Attach the chest clip between the shoulder belts.

6. Put on your helmet.



To take off the harness:

1. Unlatch the chest clip.
2. Push the red button to release the buckle.
3. Remove your arms from the shoulder belt.
4. After exiting the vehicle, buckle the harness to prevent damage which can occur if it is slammed in the door or hangs out of the vehicle.

SUB ZERO SEAT BELT HARNESS

CAUTION

If the red warning section of the safety label becomes visible at all times, this harness must be replaced.

On models equipped with a Sub Zero seat belt harness, the harness is designed to extend in the event of accident to absorb the impact. The harness must be replaced if the red section on the label appears outside the shoulder pad.

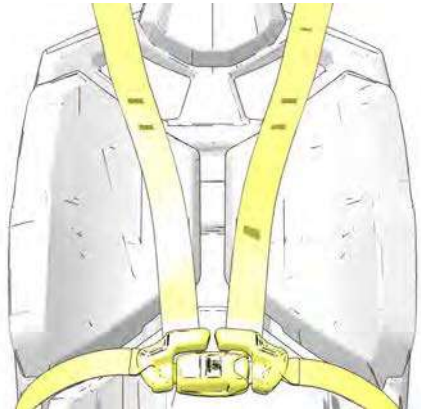

FEATURES AND CONTROLS

SERVICE ACCESS PANELS

ENGINE ACCESS PANEL

The engine access panel is located behind the seats. Adjust or remove the seats, then remove the panel to reach serviceable engine components. Remove the panel by turning the close-off knobs ① 1/4 turn.

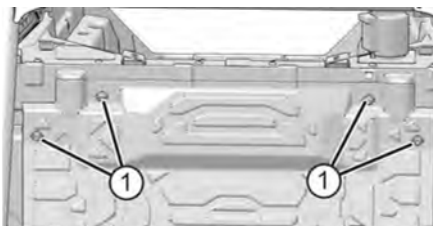

CARGO BOX ACCESS

⚠ CAUTION

The cargo box rests directly above heat-generating vehicle components. Be careful when removing the cargo box immediately following operation. It will likely be hot and could cause burns.

The entire cargo box layer can be lifted to access the engine oil fill cap and spark plugs by removing the four rear-most screws ②.



CAB DOORS

This vehicle is equipped with cab doors. Riding in this vehicle without closed and latched cab doors increases the risk of serious injury or death in the event of an accident or rollover. Always make sure all cab doors are closed and latched when riding in this vehicle.

Always inspect doors and latches for wear and damage before each use of the vehicle.

Promptly replace any worn or damaged parts with new parts available from your authorized POLARIS dealer or qualified person.

GEAR SELECTOR

The gear selector is located between the driver and passenger seat ① To change gears, stop the vehicle and with the engine idling, move the lever to the desired gear. Do not attempt to shift gears with engine speed above idle or while the vehicle is moving.

- P: Park
- R: Reverse
- N: Neutral
- L: Low Gear
- H: High Gear

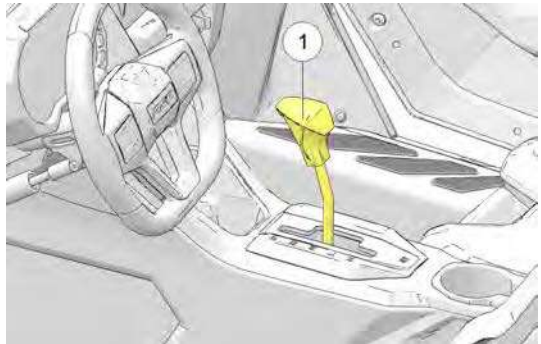

NOTICE

Maintaining shift linkage adjustment is important to assure proper transmission function. Your POLARIS dealer can assist in resolving any shifting problems.

NOTICE

Do not attempt to shift the transmission while the vehicle is moving or damage to the transmission could result. Always shift when the vehicle is stationary and the engine is at idle.

USING LOW RANGE

NOTICE

Using Low Gear during when conditions require it will prolong the life of your vehicle's drive belt.

Always shift into low gear for any of the following conditions:

- Operating in rough terrain or over obstacles
- Loading the vehicle onto a trailer
- When hauling or towing heavy cargo.
- When consistently operating at speeds less than 35 MPH (56 km/h) in hard-pulling terrain, such as mud, rocks, or sand/dune environments.

BRAKE AND THROTTLE PEDALS

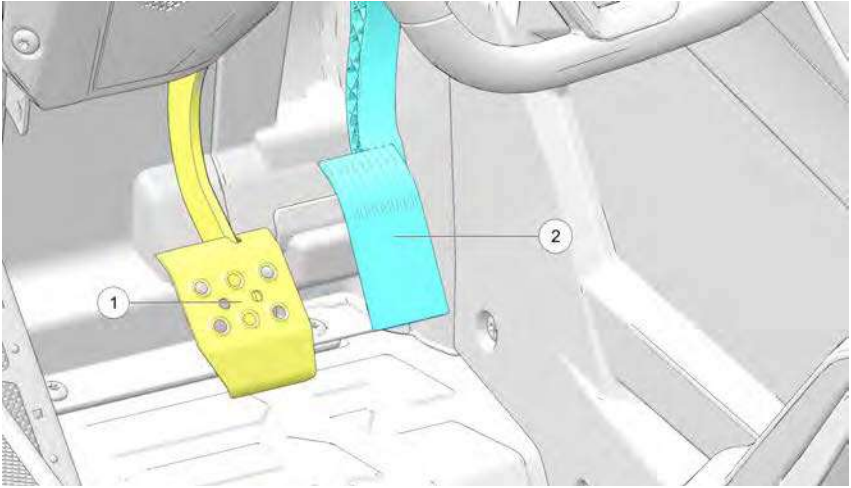

BRAKE PEDAL

Depress the brake pedal ① to slow or stop the vehicle. The brakes must be applied in order to start the engine.

THROTTLE PEDAL

Push the throttle pedal ② down to increase engine speed. Spring pressure returns the pedal to the rest position when released. Always check that the throttle pedal returns normally before starting the engine.

NOTICE

When traveling over 10 mph with the throttle pedal depressed, applying the brake for more than two seconds will disable the throttle pedal until the brake is released.

FEATURES AND CONTROLS

ROLLOVER PROTECTIVE STRUCTURE (ROPS)

The Rollover Protective Structure (ROPS) on this vehicle meets OSHASM 29CFR 1928.53 rollover performance requirements. Always have your authorized POLARIS dealer thoroughly inspect the ROPS if it ever becomes damaged in any way.

NOTE

Be mindful of the ROPS bars when boarding and exiting the vehicle.

① ROPS Label

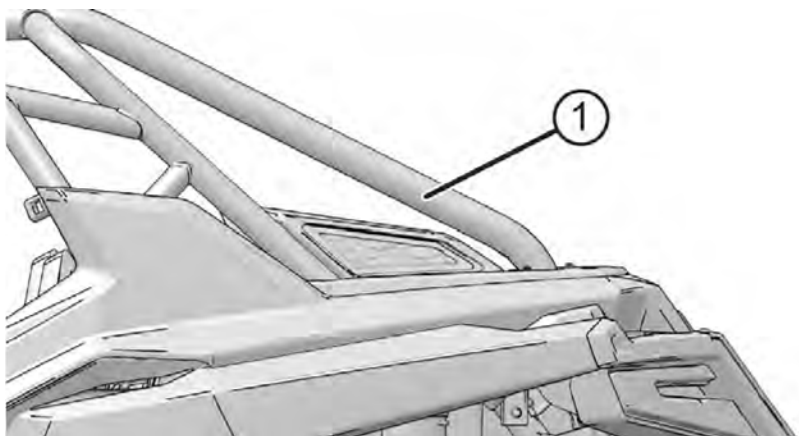



No device can assure occupant protection in the event of a rollover. When used with seat belts and cab nets or doors, the ROPS helps prevent occupants from being ejected from the vehicle. Always follow all safe operating practices outlined in this manual to avoid vehicle rollover.

WARNING

Vehicle rollover could cause severe injury or death. Always avoid operating in a manner that could result in vehicle rollover.

ALL WHEEL DRIVE (AWD) SYSTEM

The All Wheel Drive system is controlled by the AWD switch. Once the vehicle is in gear, the switch is set to one of two driveline modes.

ICON	DRIVELINE MODE	DESCRIPTION
	Two-Wheel Drive (2WD)	When the switch is set to 2WD the vehicle is in two-wheel drive at all times.
	All Wheel Drive (AWD)	<p>When the switch is set to AWD and the vehicle is in Drive or Reverse, the vehicle is in all wheel drive and the 4X4 indicator in the instrument cluster will be on</p> <p>When in AWD, the demand drive unit will automatically engage any time the rear wheels lose traction. When the rear wheels regain traction, the demand drive unit will automatically disengage.</p> <p>There is no limit to the speed or length of time the vehicle may remain in AWD.</p>

ENGAGING AWD

The AWD switch may be turned on or off while the vehicle is moving. Initially, the vehicle's electronic system will not enable the AWD until the engine RPM is below 3100 and the vehicle speed is below 15 mph (24 km/h). Once enabled, the AWD remains enabled until the AWD switch is turned off. If the switch is turned off while the demand drive unit is moving, it will not disengage until the rear wheels regain traction.

Engage the AWD switch before getting into conditions where all-wheel drive may be needed. If the rear wheels are spinning, release the throttle before switching to AWD.

NOTICE

Switching to AWD while the rear wheels are spinning or slipping may cause severe drive shaft, prop shaft, and gearcase damage. Always switch to AWD while the rear wheels have traction or are at rest.

INSTRUMENT CLUSTER

NOTICE

High water pressure may damage components. Wash the vehicle by hand or with a garden hose using mild soap. Certain products, including insect repellents and chemicals, will damage the speedometer lens and other plastic surfaces. Do not use alcohol or cleaning products containing alcohol to clean the instrument cluster. Do not allow insect sprays to contact the lens. Immediately clean off any gasoline that splashes on the instrument cluster.



- | | |
|-------------------|----------------------------|
| ① Speedometer | ④ Mode Button |
| ② Tachometer | ⑤ Toggle Buttons |
| ③ Indicator Lamps | ⑥ Rider Information Center |

SPEEDOMETER

The speedometer displays vehicle speed in either miles per hour (MPH) or kilometers per hour (km/h).

TACHOMETER

The tachometer displays engine speed in revolutions per minute (RPM).

MODE AND TOGGLE BUTTONS



Press and hold the MODE button ④ to enter or exit the settings menu. Press and release the MODE button to cycle through Area 1 modes and to select an item.

Press and release either toggle button ⑤ to cycle through the options menu or Area 2 modes. Press and hold either toggle button to reset an item. See page 64.







TIP

With the ignition key off, pressing the MODE button or either toggle button will power up the Rider Information Center for 10 seconds to allow viewing of the odometer and the clock.



INDICATOR LAMPS

INDICATOR	ICON	FUNCTION
Vehicle Speed	MPH	When standard mode is selected, speed displays in miles per hour.
	km/h	When metric mode is selected, speed displays in kilometers per hour.
Check Engine		This indicator appears if a fault occurs. Do not operate the vehicle if this warning appears. Serious engine damage could result. Your authorized POLARIS dealer can assist.
Chassis Warning		If a fault condition is detected, the light will remain on as long as the condition exists. Retrieve the error codes for diagnosis. This lamp is also known as an Amber Warning Lamp (AWL).
EPS Warning (if equipped)		This indicator illuminates briefly when the key is turned to the ON position. If the light remains on, the EPS system is inoperative. See your POLARIS dealer, or other qualified person, as soon as possible for repair. Continued operation could result in permanent damage to the EPS unit and increased steering effort. For more information, see the Electronic Power Steering (EPS) section.

FEATURES AND CONTROLS

INDICATOR	ICON	FUNCTION
Engine Hot		This lamp illuminates to indicate an overheated engine. If the indicator flashes, the overheating condition remains, and the system will automatically reduce engine power.
Check Battery		This warning usually indicates that the vehicle is operating at an RPM too low to keep the battery charged. It may also occur when the engine is at idle and high electrical load (lights, cooling fan, accessories) is applied. Drive at a higher RPM or recharge the battery to clear the warning.
PASS (PIN Activated Security System, if equipped)		The security indicator lamp illuminates when the security system is enabled.
Low Fuel		The low fuel indicator lamp illuminates when fuel level in the fuel tank is low.
Neutral		The neutral indicator lamp illuminates when the transmission is in neutral and the ignition key is in the ON position.
Helmet/Seat Belt		This lamp is a reminder to the operator to ensure all riders are wearing helmets and seat belts before operating. The driver's seat belt is equipped with a seat belt interlock. Vehicle speed will be limited to 15 MPH (24 km/h) if the seat belt is not secured.

FEATURES AND CONTROLS

INDICATOR	ICON	FUNCTION
High Beam		This lamp illuminates when the headlamp switch is set to high beam.
Park Brake (if equipped)		Lamp illuminates when the Park Brake is applied (if equipped).

FEATURES AND CONTROLS

RIDER INFORMATION CENTER

The rider information center is located in the instrument cluster. All segments will light up for one second at start-up.

If the instrument cluster fails to illuminate, a battery over-voltage may have occurred and the instrument cluster may have shut off to protect the electronic components within. If this occurs, your POLARIS dealer can provide proper diagnosis.

The information center is set to display standard units of measurement and a 12-hour clock at the factory. To change to metric and/or a 24-hour clock, see the Clock section.

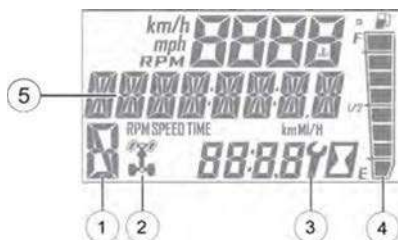

①	Gear Indicator	This indicator displays gear shifter position H = High Gear L = Low Gear N = Neutral R = Reverse Gear P = Park - = Gear Signal Error (or shifter between gears)
②	AWD Indicator	This indicator shows whether 2X4 or AWD is active when the vehicle is in gear.
③	Service Indicator	A flashing wrench symbol alerts the operator that the preset service interval has been reached. Your POLARIS dealer can provide scheduled maintenance. See page 67 for resetting instructions.
④	Fuel Gauge	The segments of the fuel gauge show the level of fuel in the fuel tank. When the last segment clears, a low fuel warning is activated. The outline of the fuel display will flash. Refuel immediately.
⑤	Speed Limitation (if equipped)	This vehicle may be equipped with a maximum speed limitation function. This would be displayed on the screen as "LIM" followed by the speed. "LIM 30" for example.

MODE INFORMATION DISPLAYS

The rider information center contains three areas that display mode information.

- ① Display Area 1
- ② Display Area 2
- ③ Display Area 3



DISPLAY AREA 1	DESCRIPTION
Engine Temperature	Temperature of engine coolant
Vehicle Speed	Speed of vehicle
Tachometer	Engine speed (RPM)

DISPLAY AREA 2	DESCRIPTION
Odometer	Records and displays the distance traveled by the vehicle.
Trip Meters (T1/T2)	Records the distance traveled by the vehicle if reset before each trip. To reset, see page 66.
Voltmeter	Displays the vehicle's electric output.
Engine Hours	Total hours of engine operation since manufacture.
Service Hours	A flashing wrench symbol indicates that the preset service interval has been reached. To reset, see page 67.
Engine Temperature	Temperature of engine coolant

DISPLAY AREA 3	DESCRIPTION
Clock	The clock displays time in a 12-hour or 24-hour format. To reset, see page 65.

FEATURES AND CONTROLS

ACCESSING MENUS AND OPTIONS

GAUGE SETTINGS MENU

Press and release the MODE button to cycle through the Area 1 modes until the desired default mode displays. See the Mode Information Displays section for details.

Press and hold the MODE button to enter the settings menu.

The OPTIONS screen will display for a few seconds.

1. Press and release either toggle button to cycle to the desired option.
2. Press MODE to select the option.
3. Press either toggle button to cycle to the desired setting.
4. Press MODE to save and exit to the settings menu.
5. Press and hold the MODE button to exit the settings menu.



BACKLIGHT COLOR

The information center backlight can be set to either blue or red.

1. Press and hold the MODE button to enter the settings menu.
2. Press either toggle button to cycle to the "BL COLOR" option. Press MODE to select.
3. Press either toggle button to cycle to the desired setting.
4. Press MODE to save and exit to the settings menu,



BACKLIGHT BRIGHTNESS

The information center backlight brightness can be adjusted.

1. Press and hold the MODE button to enter the settings menu.
2. Press either toggle button to cycle to the "BL LEVEL" option. Press MODE to select.
3. Press "UP" button to increase brightness. Press "DOWN" button to decrease brightness.
4. Press MODE to select and exit to the settings menu.



CLOCK

The clock must be reset any time the battery has been disconnected or discharged.

1. Press and hold the MODE button to enter the settings menu.
2. Press either toggle button to cycle to the "CLOCK" option. Press MODE to select.
3. Press either toggle button to cycle to the desired setting (12H or 24H). Press MODE to select.
4. Press either toggle button to change each segment of the clock. Press MODE to accept a change and advance to the next segment.



FEATURES AND CONTROLS

DISPLAY UNITS (STANDARD/METRIC)



1. Press and hold the MODE button to enter the settings menu.
2. Press either toggle button to cycle to the desired "UNITS" option (distance, temperature or volume). Press MODE to select.
3. Press either toggle button to cycle to the desired setting.
4. Press MODE to save and exit to the settings menu.

TRIP METER

Use a trip meter to track the distance traveled during a specific trip or period of time. Reset the meter to zero before traveling.

1. Press either toggle button to cycle to the desired trip meter option (T1 or T2).
2. Press and hold either toggle button until the meter resets to zero.



PROGRAMMABLE SERVICE INTERVAL

The service interval counter is programmed to 25 hours at the factory. As hours of engine operation increase, the counter decreases. The wrench icon will flash for about 10 seconds when the counter reaches zero (0), and each time the key is turned on thereafter, until the counter is reset.

When this feature is enabled, it provides a convenient reminder to perform routine maintenance. Refer to the Periodic Maintenance Chart for recommended service intervals.

Use the following procedure to reset or change the service interval.

1. Press and hold the MODE button to enter the settings menu.
2. Press either toggle button to cycle to the "Service Hours" option. Press MODE to select.
3. Press MODE to reset the existing value and exit, or press either toggle button to change the value. Press MODE to save and exit to the settings menu.



FEATURES AND CONTROLS

PIN ACTIVATED SECURITY SYSTEM (P.A.S.S.) (IF EQUIPPED) — INSTRUMENT CLUSTER

For vehicles with the Ride Command display, see page 76 for details.

The optional PIN Activated Security System (P.A.S.S.) is designed to prevent unauthorized use. When enabled, the vehicle cannot be operated until a valid passcode has been entered.

To enable/disable P.A.S.S., follow the procedures below.

ENABLE P.A.S.S.

NOTICE

After activating P.A.S.S. for the first time you must power down the vehicle and allow the electronic control module (ECM) to fully shutdown before restarting.

This may take up to three minutes.

Once a new passcode has been enabled, it cannot be changed unless you first disable the system. Then you can re-follow the steps outlined in the ENABLE P.A.S.S. section to enter a new passcode.

1. Press and hold the MODE button to enter the “OPTIONS” menu.
2. Use the UP/DOWN toggle buttons to cycle through options until “REQUIRE PIN TO START” appears. Press the MODE button to select.
3. If required, “ENTER NEW PIN” will appear. Use the UP/DOWN toggle buttons to cycle to your desired first digit. Press the MODE button to select the digit.
4. Continue until all four digits of your desired passcode have been selected. Once finished, “NEW PIN SET” will flash momentarily and then revert back to the “REQUIRE PIN TO START” screen.

Record your passcode for future reference.

5. To enable your new passcode, use the UP/DOWN toggle buttons to change the flashing “OFF” at bottom of screen to “ON”. **If this step is skipped, P.A.S.S. will not be enabled.**
6. Press the MODE button to re-enter the “OPTIONS” menu. The vehicle will now require passcode entry before next startup.

You can exit the “OPTIONS” menu three different ways.

- Toggle to “EXIT” and press the MODE button.
- Hold the MODE button for a few seconds.
- Do nothing, allowing the system to automatically revert back to the main screen.

NOTICE

If the battery becomes low while the P.A.S.S. system is enabled, the gauge may show "New Vehicle Detected" after the battery has been recharged/replaced. Leave the key in the ON position to allow system reconfirmation.

DISABLE P.A.S.S.

1. Press and hold the MODE button to enter the "OPTIONS" menu.
2. Use the UP/DOWN toggle buttons to cycle through options until "REQUIRE PIN TO START" appears. Press the MODE button to select.
3. Enter current passcode.
4. Use the UP/DOWN toggle buttons to change the flashing "ON" at bottom of screen to "OFF".
5. Press the MODE button to re-enter the "OPTIONS" menu. P.A.S.S. is now disabled.

You can exit the "OPTIONS" menu three different ways.

- Toggle to "EXIT" and press the MODE button.
- Hold the MODE button for a few seconds.
- Do nothing, allowing the system to automatically revert back to the main screen.

FEATURES AND CONTROLS

ENGINE ERROR CODES

The error screen displays only when the CHECK ENGINE indicator is on or when it goes on and off during one ignition cycle. Error codes are not stored. When the key is turned OFF, the code and message is lost, but will reappear if the fault reoccurs after restarting the engine.

If the CHECK ENGINE lamp or the EPS lamp illuminates, retrieve the active error codes from the display.

- ① Failure Mode Indicator (FMI)
- ② Suspect Parameter Number (SPN)
- ③ Code Count

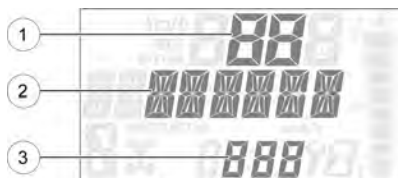

1. Press and hold the MODE button to enter the settings menu.
2. Press either toggle button to cycle to the "DIAGCODE" option. Press MODE to select.
3. More than one diagnostic code may be present. Press the toggle UP button to see if more codes are present. Press MODE to select a code.

NOTICE

If the displayed code is an engine fault code, the CHECK ENGINE lamp will blink. If the displayed code is an EPS fault code, the EPS lamp will blink.

4. Record the three (3) numbers displayed.
5. Press MODE to exit to the settings menu.

RIDE COMMAND DISPLAY (IF EQUIPPED)

BEFORE YOU RIDE

Before riding with your new display, do the following:

- Read this and the Ride Command User's Guide in their entirety.
- Familiarize yourself with the features and operations of the Display while the vehicle is stationary.
- Download the Polaris RIDE COMMAND App from the Apple® App Store® or Google Play® store and create your personalized account.
- Check your display to ensure you have the appropriate maps and trails visible for your area. To change or update maps/trails see page 82.
- Check <https://www.polaris.com/en-us/owners-manuals/> for the latest updates to the owner's manual.

NOTICE

Trails change often, and the trail data file is only considered valid for 90 days after the release date. Please keep your trail data up to date. Download the latest trails at <http://ridecommand.polaris.com>.

NOTICE

Using the display for an extended period of time while the vehicle's engine is off can drain the battery.

DEVICE OPERATING REQUIREMENTS

Phone functionality is dependent on the capabilities of your cell phone.

NOTICE

Some cell phones or operating systems will not work as shown in this manual.

RIDE COMMAND DISPLAY (IF EQUIPPED)

DEVICE COMPLIANCE STATEMENTS

USA RADIO COMPLIANCE

This vehicle contains the following radio equipment or components that contain radio equipment:

COMPONENT	COMPONENT ID	MANUFACTURER
9200 Series Display	RC-7	Polaris Industries Inc.

This device complies with part 15 of the FCC Rules. Operation is subject to the following two conditions: (1) This device may not cause harmful interference, and (2) this device must accept any interference received, including interference that may cause undesired operation.

CAUTION

Changes or modifications not expressly approved by the party responsible for compliance could void the user's authority to operate the equipment.

CANADA RADIO COMPLIANCE

This vehicle contains the following radio equipment or components that contain radio equipment:

COMPONENT	COMPONENT ID	MANUFACTURER
9200 Series Display	RC-7	Polaris Industries Inc.

This device contains license-exempt transmitter(s)/receiver(s) that comply with Innovation, Science and Economic Development Canada's license-exempt RSS (s). Operation is subject to the following two conditions:

1. This device may not cause interference.
2. This device must accept any interference, including interference that may cause undesired operation of the device.

IMPORTANT

For applications that use vehicle-to-vehicle (V2V) communication, radio transmitter IC 5966A-P001 has been approved by Innovation, Science and Economic Development Canada (ISED) to operate with Polaris antenna (part number 4018713) with gain of 3 dBi. Any antenna that has a gain greater than 3 dBi is prohibited for use with this device.

RIDE COMMAND DISPLAY (IF EQUIPPED)

EUROPEAN UNION (EU) RADIO COMPLIANCE

This vehicle contains the following radio equipment or components that contain radio equipment:

Component	9200 Series Display
Component ID	RC-7
Manufacturer	Polaris Industries Inc.
*Transmitting Frequency	2402 - 2480 MHz
Max RF Transmitting PWR	0.2432 W
*Other transmitting radio frequencies may exist outside of EU markets.	

Hereby, Polaris Industries Inc. declares that the above radio equipment is in compliance with Directive 2014/53/EU.

The full text of the EU declaration of conformity is available at the following internet address:

<https://www.polaris.com/en-us/radio-conformity/>

RIDE COMMAND DISPLAY (IF EQUIPPED)

OVERVIEW



① Ride Command Buttons

② Driveline Mode

③ Widgets

④ Settings



⑤ Icon Bar

⑥ Gauge View Mode





⑦ Speedometer/Tachometer

⑧ Gear Status

RIDE COMMAND BUTTONS

BUTTON	DESCRIPTION	FUNCTION
	Menu Button	Press the Menu button to access the settings. To reboot the display, press and hold for 5 seconds.
	Gauge Screen Button	Press the Gauge Screen button to select from available screens.

RIDE COMMAND DISPLAY (IF EQUIPPED)

BUTTON	DESCRIPTION	FUNCTION
	Map Button	Press the Map button to access the map, manage your rides and waypoints, and to see your friends on the map with Group Ride.
	Phone Button	Press the Phone button to access your Bluetooth® connected phone, including recent calls, contacts, dialer, and messages.
	Audio Button	Press the Audio button to access the Radio, Weather, USB, and connected Bluetooth® music interface
	Volume Decrease Button	Press the Volume Decrease button to decrease the volume. Press and hold to mute volume.
	Volume Increase Button	Press the Volume Increase button to increase the volume.

RIDE COMMAND DISPLAY (IF EQUIPPED)

PIN ACTIVATED SECURITY SYSTEM (P.A.S.S.) (IF EQUIPPED) — RIDE COMMAND

The optional PIN Activated Security System (P.A.S.S.) is to prevent unauthorized use. When enabled, the vehicle cannot be operated until a valid passcode has been entered using the Ride Command display screen.

ENABLE P.A.S.S.

NOTICE

After activating P.A.S.S. for the first time you must power down the vehicle and allow the electronic control module (ECM) to fully shutdown before restarting. This may take up to three minutes.

1. Go to the settings menu by pressing the Menu button.
2. Select Vehicle Settings from the left toolbar.
3. Select Engine Start Lockout.
4. If this your first time activating P.A.S.S. you will be prompted to enter a new passcode. Enter and verify new passcode.
Record your passcode for future reference.
5. Turn Engine Start Lockout from No to Yes.
6. Turn off the vehicle using the key ignition switch.

NOTICE



If the battery becomes low while the P.A.S.S. system is enabled, the gauge may show "New Vehicle Detected" after the battery has been recharged/replaced. Leave the key in the ON position to allow system reconfirmation.

DISABLE P.A.S.S.

1. Go to the settings menu by pressing the Menu button.
2. Select Vehicle Settings from the left toolbar.
3. Select Engine Start Lockout.
4. Enter passcode to disable P.A.S.S.
5. Turn Engine Start Lockout from Yes to No.

RIDE COMMAND DISPLAY (IF EQUIPPED)

DRIVELINE MODE

INDICATOR	DESCRIPTION	FUNCTION
	2WD	When the switch is on 2X4, the vehicle is in two-wheel drive at all times.
	AWD	When in All-Wheel Drive, the demand drive unit will automatically engage any time the rear wheels lose traction. When the rear wheels regain traction, the demand drive unit will automatically disengage. There is no limit to the length of time the vehicle may remain in 4X4. The vehicle automatically engages 4X4 when operating in reverse if the switch is set to 4X4 position.
	Turf Mode (if equipped)	When operating in TURF mode, the inside rear wheel will rotate independently from the outside wheel during turns. Operate in TURF mode only as needed to protect smooth, level surfaces from tire damage. DO NOT operate in TURF mode when climbing or descending hills, when sidehilling, or when operating on uneven, loose, or slippery terrain such as sand, gravel, ice, snow, obstacles, and water crossings. Always operate in AWD on these types of terrain.

RIDE COMMAND DISPLAY (IF EQUIPPED)

GAUGE SCREENS

Press the Gauge Screen button to toggle between gauge screens. The display comes loaded with two different gauge screens. Additional gauge screens can be added or deleted.

Each gauge screen is customizable and can be set up in the following configurations:

- Four round widgets
- Two round widgets and a list of three data values
- A list of five data values

To customize your gauge screens, press the gear icon located in the lower right corner of the display.



SETTINGS

From the setting menu you can view vehicle information, manage Bluetooth® devices, update display software, and more.

To access the Setting menu, press the Menu button ①.

You can also navigate to the settings menu by pressing the POLARIS logo at the top of the display screen ②. This will open the Control Panel. From the Control Panel, select the settings tab, then press the **All Settings** button located in the lower right corner of the display screen.



GAUGE VIEW MODE

Press ① to toggle between the two available gauge view modes, **Analog** and **Digital**.

While in the digital gauge view mode, press ② to invert the MPH and RPM units.



DISPLAY MODE

From the Control tab ③, select the display mode from the available options ④.

The display mode can be set to Day, Night, or AUTO mode.

Day Mode



Night Mode



RIDE COMMAND DISPLAY (IF EQUIPPED)

ICON BAR



ICON	DESCRIPTION	FUNCTION
①	Headset	Displays icon if headset is connected
②	Signal Strength	Displays current cell signal strength
③	Wireless Internet Signal Strength (if equipped)	Displays current wireless internet signal strength (if equipped)
④	Fuel Level	Displays current fuel capacity percentage
⑤	Vehicle Direction	Displays vehicle direction
⑥	Ambient Temperature	Displays ambient temperature
⑦	Clock	Displays current time

UPDATE SOFTWARE

NOTICE

Before updating the Display, always export your existing rides and waypoints to a USB drive to avoid losing them.

To update the software, do the following:

ON YOUR PERSONAL COMPUTER

1. Go to ridecommand.polaris.com/update.
2. Log into your account, or create a new account.
3. Using the Vehicle Identification Number (VIN), add your new Polaris vehicle to your Garage.
4. Locate and download the latest software to a USB flash drive (8+ GB).

ON YOUR VEHICLE

1. Connect the USB flash drive to the USB cable and power up your vehicle.
2. On the RIDE COMMAND display, select the Settings menu on your display by pressing the POLARIS icon at the top of the screen.
3. Select General Settings, then Update Software.
4. Select the file you wish to load (use date listed in the file name to determine most recent file).
5. Select Yes to restart display (restart required).

ERROR MESSAGES

If an error occurs while updating your software, perform one or all of the following actions to resolve the issue:

1. Remove and reconnect the USB flash drive securely.
2. Make sure the display files are not inside a folder on the flash drive.
3. Make sure only display files are on the flash drive. Remove any other files if necessary.
4. Try using a different USB flash drive.

RIDE COMMAND DISPLAY (IF EQUIPPED)

UPDATE MAPS

To update the maps on your display, do the following:

1. Go to ridecommand.polaris.com/update and download the map update to a USB flash drive.
2. Insert USB flash drive into the USB port on your vehicle.
3. Press the Update maps in the General Settings.
4. Select the file you want to install by pressing the corresponding down arrow icon.
5. This will update the display's map which will automatically restart the display once the update is complete. Do not remove the USB flash drive until the display has fully restarted.

USB HARDWARE

SOFTWARE UPDATES

For software update, POLARIS recommends using a SanDisk® or similar USB flash drive with a minimum of 4GB in available memory, formatted using the FAT32 or exFAT® file systems. For best results remove all files from the flash drive before starting the update process.

MAP UPDATES

For Map updates, a 32GB USB drive is required (USB 3.0 drive is highly recommended) USB drive must be formatted to exFAT® before copying the map file onto it.

TRAIL UPDATES

For Trail updates, a 4GB drive formatted to FAT32 can be used.

OPERATION

VEHICLE BREAK-IN

ENGINE AND DRIVETRAIN BREAK-IN

1. Fill the fuel tank with the recommended fuel. See the Refueling section for details. Always exercise extreme caution whenever handling fuel.
2. Check the oil level. See the Oil Check section for details. Add the recommended oil as needed to maintain the oil level in the safe operating range.
3. Avoid aggressive use of the brakes.
4. Vary throttle positions. Do not operate at sustained idle.
5. Perform regular checks on fluid levels, controls and areas outlined on the daily pre-ride inspection checklist.
6. Carry only light loads.
7. During the break-in period, change both the oil and the filter at 25 hours, one month, or 500 miles, whichever comes first.
8. Check fluid levels of transmission and all gearcases after the first 25 hours of operation and every 50 hours thereafter.

BRAKE SYSTEM BREAK-IN

Apply only moderate braking force for the first 50 stops. Aggressive or overly forceful braking when the brake system is new could damage brake pads and rotors.

OPERATION

PVT BREAK-IN (CLUTCHES / BELT)

A proper break-in of the clutches and drive belt will ensure a longer life and better performance. If a belt fails, always clean any debris from the duct and from the engine compartment.

STANDARD BREAK-IN

Drive at slower speeds for the first 50 miles (80 km) of operation. Carry only light loads. Avoid aggressive acceleration, high-speed operation and prolonged operation at a specific RPM during this period.

SAND / DUNE BREAK-IN

Drive in low gear for the first 5 miles (8 km) of operation. Avoid prolonged low speed operation at high throttle. Avoid aggressive acceleration, high-speed operation and prolonged operation at a specific RPM during this period.

BELT LIFE

To extend belt life, use low gear in the following conditions:

- When hauling or towing heavy cargo
- When consistently operating at speeds less than 35 MPH (56 km/h) in hard-pulling terrain, such as mud, rocks or sand/dune environments.

OPERATING GUIDELINES

STARTING THE ENGINE

NOTICE

Operating the vehicle immediately after starting could cause engine damage. Allow the engine to warm up for several minutes before operating the vehicle.

1. Position the vehicle on a level surface outdoors or in a well-ventilated area.
2. Sit in the driver's seat and fasten the seat belt. Always make sure all cab doors are closed and latched when riding in this vehicle.
3. Place the transmission in PARK.
4. Apply the brakes. Do not press the throttle pedal while starting the engine.
5. Turn the ignition key past the ON/RUN position and release immediately to START. The engine will turn over for a maximum five seconds until the vehicle has started.
6. If the engine does not start within five seconds, return the ignition switch to the OFF position and wait five seconds. Repeat steps 5 and 6 until the engine starts.
7. After starting the engine, wait 10 seconds before applying throttle.

BRAKING

1. Release the throttle pedal completely.

TIP

When the throttle pedal is released completely and engine speed slows to near idle, the vehicle has no engine braking.

2. Press on the brake pedal evenly and firmly.
3. Practice starting and stopping (using the brakes) until you're familiar with the controls.

OPERATION

DRIVING IN REVERSE

 WARNING

Before shifting into reverse, use extra care to make sure the area is clear of people or obstacles. When it's safe to proceed, back slowly.

Follow these precautions when operating in reverse:

1. Always check for obstacles or people behind the vehicle.
2. Apply the throttle *lightly*. Never open the throttle suddenly.
3. Back slowly.
4. Apply the brakes *lightly* for stopping.
5. Avoid making sharp turns.

STOPPING THE ENGINE AND PARKING THE VEHICLE

 WARNING

When leaving the vehicle on an incline is unavoidable, use extra care. Vehicle rollaway can cause serious injury or death. This vehicle can roll whenever the gear selector is not in the PARK (P) position. Always shift to PARK (P) when stopping the engine or leaving the vehicle. If leaving the vehicle unattended, block the rear wheels on the downhill side and keep children, pets, and others away from the gear selector.

To park the vehicle:

1. Stop the vehicle on a level surface.
2. Place the transmission in PARK (P). This vehicle can roll whenever the transmission is not in the PARK (P) position.
3. Stop the engine.
4. Engage the park brake (if equipped).
5. Remove the ignition key to prevent unauthorized use.

EMISSION CONTROL SYSTEMS

NOISE EMISSION CONTROL SYSTEM

Do not modify the engine, intake or exhaust components, as doing so may affect compliance with U.S.A. EPA noise control requirements (40 CFR 205) and local noise level requirements.

OPERATION ON PUBLIC LANDS IN THE U.S.A.

Your POLARIS vehicle has a spark arrester that was tested and qualified to be in accordance with the USFS standard 5100-1d. Federal law requires that this spark arrester be installed and functional when the vehicle is operated on public lands.

Operation of off-road vehicles on public lands in the U.S.A. is regulated by 43 CFR 420. Violations are subject to monetary penalties. Federal regulations can be viewed online at www.ecfr.gov.

CRANKCASE EMISSION CONTROL SYSTEM

This engine is equipped with a closed crankcase system. Blow-by gases are forced back to the combustion chamber by the intake system. All exhaust gases exit through the exhaust system.

EXHAUST EMISSION CONTROL SYSTEM

Exhaust emissions are controlled by engine design. An electronic fuel injection (EFI) system controls fuel delivery. The engine and EFI components are set at the factory for optimal performance and are not adjustable.

The emissions label is located on the left front frame of the vehicle.

ELECTROMAGNETIC INTERFERENCE

This spark ignition system complies with Canadian ICES-002.

This vehicle complies with EMC requirements of UN ECE Regulation 10 and European directives 97/24/EC and 2004/108/EC.

Non-ionizing Radiation: This vehicle emits some electromagnetic energy. People with active or non-active implantable medical devices (such as heart monitoring or controlling devices) should review the limitations of their device and the applicable electromagnetic standards and directives that apply to this vehicle.

MAINTENANCE

PERIODIC MAINTENANCE

 **WARNING**

Do not attempt any maintenance procedures that are not described in this manual or that you are not comfortable performing. Some maintenance procedures are more extensive and may require special training, tools, and equipment. An authorized POLARIS dealer can perform any service that may be necessary for your vehicle.

 **WARNING**

Be sure to properly reinstall all components that were removed during any maintenance. For example, some parts are made and positioned to deflect heat, and failing to reinstall heat shields properly can lead to a fire.

 **WARNING**

Hot parts can cause burns. To avoid burns, do not touch hot components or attempt maintenance before allowing to cool. Surfaces that could be hot during and after operation can include components of the:

- Engine and exhaust
- Brakes
- Shock absorbers

 **WARNING**

Before service or maintenance, make sure the transmission is in Park and the engine is off with the key removed. Moving parts can contact body parts or clothing. Running the engine while servicing can lead to serious injury, electric shock, burns, fire, carbon monoxide poisoning, and death.

 **WARNING**

Do not run engine with any covers removed. Contact with exposed belt or moving parts can cause serious injury.

MAINTENANCE

WARNING

Vehicle fluids such as oil or brake fluid can be hazardous. Wear gloves and avoid skin contact. Always follow the handling and disposal instructions provided by the fluid manufacturer.

SEVERE USE DEFINITION

Vehicles subjected to heavy or severe use patterns must be inspected and serviced more frequently. Vehicles subjected to severe use must be serviced at 50% of the stated interval. Examples of severe use include:

- Frequent immersion in mud, water, or sand
- Prolonged low speed, heavy load operation
- Extended idle
- Sustained high-RPM use
- Frequent short trip operation in cold weather (engine frequently does not operate long enough to reach full operating temperature)

IMPORTANT

Pay special attention to the oil level. A rise in oil level during cold weather can indicate contaminants collecting in the oil sump or crankcase. Change oil immediately if the oil level begins to rise. Monitor the oil level, and if it continues to rise, discontinue use and determine the cause. Your POLARIS dealer or other authorized person can assist.

POLARIS MAINTENANCE SCHEDULE

The intervals shown are based on vehicles operated under normal conditions.

Each interval is given in hours and miles (kilometers). Items should be serviced at whichever interval comes first following the **Initial Break-In Service**.

Continue to reference the following maintenance schedules at the given intervals as hours and miles (kilometers) increase on the vehicle.

Vehicles subjected to severe use must be serviced at 50% of the stated interval. Examples of Severe Use: Frequent immersion in mud, water, or sand, constant high RPM use, prolonged low-speed heavy load operation, extended idle, and short trip cold weather operation.

INITIAL BREAK-IN SERVICE FIRST 25 HOURS / 1 MONTH

Air Filter	Inspect air filter; replace as necessary. Ensure proper installation of filter and airbox cover. Inspect ducts and screens; clean as necessary.
Cooling System	Fluid level inspection; inspect for fluid leaks; add coolant if needed. Inspect coolant strength seasonally; pressure test system yearly.
General Lubrication	Locate all applicable fittings and grease.
Shift Cable / Linkage	Inspect; adjust as needed
Parking Brake (if applicable)*	Inspect and adjust as needed.
Battery	Check terminals; terminals should be tight and free of corrosion. Clean, test, and replace as necessary.
Engine Oil and Filter	Change the engine oil and filter.
Front Gearcase Fluid	Initial fluid level inspection; inspect for fluid leaks; add lubricant if needed.
Transmission Fluid	Initial fluid level inspection; inspect for fluid leaks; add lubricant if needed.
Spark Arrestor	Clean out.
<p>The break-in period consists of the first 25 hours of operation. Careful treatment of a new engine and drive components will result in more efficient performance and longer life for these components. The items outlined in this service interval only need to be performed at the first 25 hours of operation. They do not need to be performed every 25 hours.</p>	
<p>* It is recommended to have an authorized Polaris dealer perform these services.</p>	

MAINTENANCE

Vehicles subjected to severe use must be serviced at 50% of the stated interval. Examples of Severe Use: Frequent immersion in mud, water, or sand, constant high RPM use, prolonged low-speed heavy load operation, extended idle, and short trip cold weather operation.

EVERY 25 HOURS / 500 MILES (1600 KM) OR YEARLY FOLLOWING INITIAL BREAK-IN SERVICE

Air Filter	Inspect air filter; replace as necessary. Ensure proper installation of filter and airbox cover. Inspect ducts and screens; clean as necessary.
Battery	Check terminals; terminals should be tight and free of corrosion. Clean, test, and replace as necessary.
Brake System	Fluid level inspection; inspect for fluid leaks; add lubricant if needed. Inspect brake pad wear.
General Lubrication	Locate all applicable fittings and grease.
Radiator	Inspect; Clean external surfaces.
Tires	Inspect; Adjust pressure level as needed; Inspect wear and replace as needed.
* Have an authorized Polaris dealer or other qualified person perform these services.	

Vehicles subjected to severe use must be serviced at 50% of the stated interval. Examples of Severe Use: Frequent immersion in mud, water, or sand, constant high RPM use, prolonged low-speed heavy load operation, extended idle, and short trip cold weather operation.

EVERY 50 HOURS / 1000 MILES (3200 KM) OR YEARLY FOLLOWING INITIAL BREAK-IN SERVICE

Air Filter	Inspect air filter; replace as necessary. Ensure proper installation of filter and airbox cover. Inspect ducts and screens; clean as necessary.
Battery	Check terminals; terminals should be tight and free of corrosion. Clean, test, and replace as necessary.
Brake System	Fluid level inspection; inspect for fluid leaks; add lubricant if needed. Inspect brake pad wear.
General Lubrication	Locate all applicable fittings and grease.
Radiator	Inspect; Clean external surfaces.
Tires	Inspect; Adjust pressure level as needed; Inspect wear and replace as needed.
Engine Oil and Filter	Change the engine oil and filter.
Spark Plug	Replace as needed.
Wiring	Inspect for wear, routing, and retention.
Front Gearcase Fluid	Change fluid.
Transmission Fluid	Change fluid.
Drive Belt	Inspect; replace as needed.
Spark Arrestor	Clean out.
Suspension Components / Alignment*	Inspect front and rear suspension bushings, and ball joints for loose or worn components; replace as needed. Inspect shock absorbers for leaks or damage.
Cooling System	Fluid level inspection; inspect for fluid leaks; add coolant if needed. Inspect coolant strength seasonally; pressure test system yearly.

MAINTENANCE

EVERY 50 HOURS / 1000 MILES (3200 KM) OR YEARLY FOLLOWING INITIAL BREAK-IN SERVICE

Wheel Bearings	Inspect; replace as needed
Parking Brake (if applicable)*	Inspect and adjust as needed.
Fuel System*	Cycle key to pressurize fuel pump; check for leaks at fuel system connections, check for leaks at fill cap.
Throttle Body / Intake Ducts / Flanges	Inspect ducts for proper sealing / air leaks
Shift Cable / Linkage	Inspect; adjust as needed
Steering Components	Inspect; replace as needed.
* Have an authorized Polaris dealer or other qualified person perform these services.	

Vehicles subjected to severe use must be serviced at 50% of the stated interval. Examples of Severe Use: Frequent immersion in mud, water, or sand, constant high RPM use, prolonged low-speed heavy load operation, extended idle, and short trip cold weather operation.

ADDITIONAL MAINTENANCE INTERVALS

Every 2000 miles (3200KM) / 24 months / 2 years	Brake Fluid	Change fluid.
	Clutches*	Inspect bushings, rollers, wearable parts; clean; replace worn parts.
Every 2500 miles (4000KM)	Shock Absorbers*	Inspect; replace or rebuild (if applicable).
Every 4000 miles (6400KM)	Valve Clearance*	Inspect; adjust as needed.
Every 5000 miles (8900KM) / 60 months / 5 years	Coolant	Change fluid.
* Have an authorized Polaris dealer or other qualified person perform these services.		

LUBRICATION RECOMMENDATIONS

Check and lubricate all components at the intervals outlined in the Periodic Maintenance Chart beginning on page 89, or more often under severe use, such as wet or dusty conditions. Items not listed in the chart should be lubricated at the general lubrication interval.

ITEM	LUBE	METHOD
Engine Oil	PS-4 5W-50 4-Cycle Oil and PS-4 Extreme Duty 0W-50 4-Cycle Oil	See page 99.
Brake Fluid	DOT 4 Brake Fluid	Maintain level between fill lines. See page 126.
Transmission Oil (Main Gearcase)	AGL Gearcase Lubricant & Transmission Fluid	See page 102.
Front Gearcase Fluid (Demand Drive)	Demand Drive Fluid	See page 105.
Prop Shaft	U-Joint Grease	Grease the fitting.
Rear Stabilizer Bar Bushings	All Season Grease or grease conforming to NLGI No. 2	Remove engine access panel and grease 2 fittings (one on each side of vehicle).

MAINTENANCE

- ① Middle Prop Shaft Grease Fitting
- ② Rear Stabilizer Bar Bushings (one on each side of vehicle)

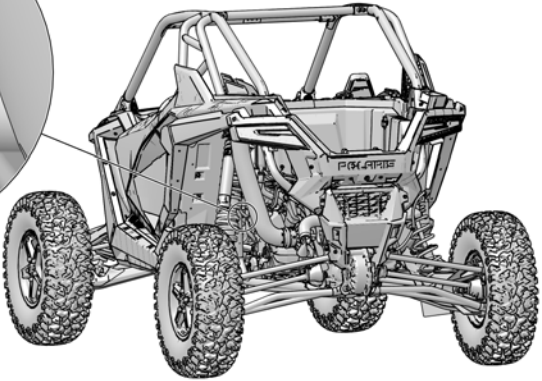
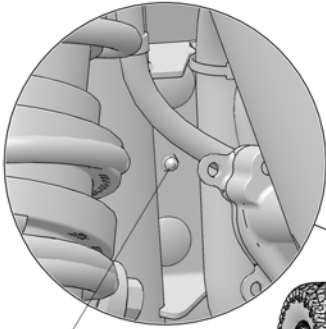
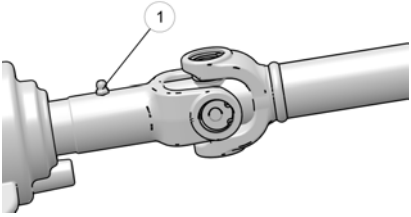

ENGINE OIL

OIL RECOMMENDATIONS

 **WARNING**

Vehicle operation with insufficient, deteriorated, or contaminated engine oil will cause accelerated wear and may result in engine seizure, accident, and injury. Always perform the maintenance procedures as outlined in the Periodic Maintenance Chart.

Ambient Temperature Range	Recommended Oil
-35 °F to +100 °F (-37 °C) to (+38 °C)	PS-4 5W-50 4-Cycle Oil
-45 °F to +130 °F (-43 °C) to (+54 °C)	PS-4 Extreme 0W-50 4-Cycle Oil

Oil may need to be changed more frequently if POLARIS oil is not used. Do not use automotive oil. Follow the manufacturer's recommendations for ambient temperature operation. Part numbers can be found in the POLARIS Products chapter.

NOTICE

Mixing brands or using a non-recommended oil may cause serious engine damage. Always use the recommended oil. Never substitute or mix oil brands.

Always check and change the oil at the intervals outlined in the Periodic Maintenance Chart. Always use the recommended engine oil.

MAINTENANCE

OIL CHECK

Always check the oil when the engine is cold and on a level surface. If the engine is hot when the oil is checked, the level will appear to be overfull.

Access the oil check dipstick ① through the right rear wheel well. Access the oil fill cap ② by removing the cargo box. See the Service Access Panels section for details.

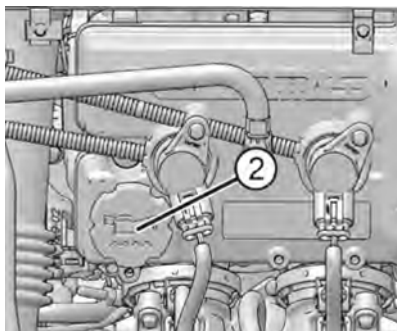
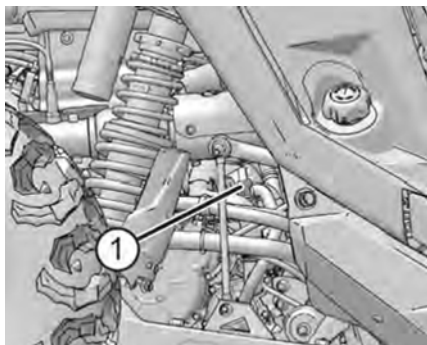

1. Position the vehicle on a level surface.
2. Place the transmission in PARK.
3. Start the engine. Allow the engine to idle for 30 seconds.
4. Stop the engine. Wait two (2) minutes to allow oil to drain back to the sump.
5. Remove the dipstick. Wipe it dry with a clean cloth.
6. Reinstall the dipstick completely. Remove the dipstick and check the oil level.
7. Remove the oil fill cap to add the recommended oil as needed. Maintain the oil level between the minimum and maximum marks on the dipstick. Do not overfill.
8. Reinstall the fill cap. Reinstall the dipstick.

OIL AND FILTER CHANGE

WARNING

Spilled oil left on engine components or in the engine area may pose a fire hazard. Use shop rags to clean any spilled oil. If needed, use a non-flammable solvent on the rag to aid the cleaning process. Do not use any device such as pressurized water or air as this may disperse the oil onto engine components and could pose a fire hazard.

Always change the oil and filter at the intervals outlined in the Periodic Maintenance Chart section.

1. Position the vehicle on a level surface. Place the transmission in PARK.
2. Allow engine to cool down before draining oil.
3. Place a drain pan under the engine crankcase and remove the drain plug ①.

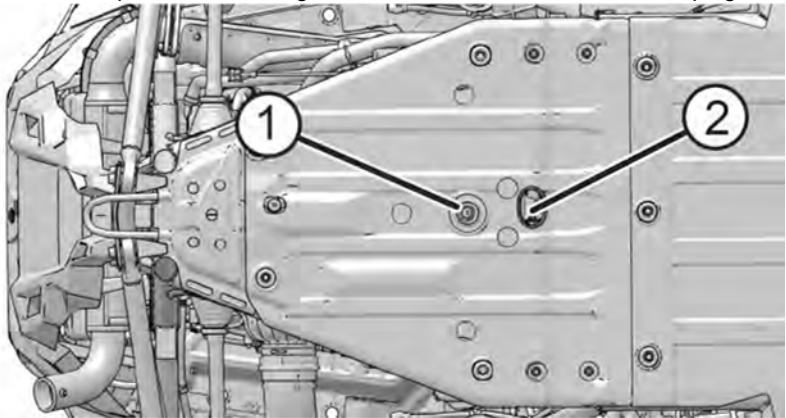

4. Access the oil filter through the access panel behind the seats. See the Service Access Panels section for details.

NOTE

The engine should be off for at least 2 minutes prior to removing the oil filter.

5. Place drain pan under filter drain ② to catch any spilled oil during removal. Using the Oil Filter Wrench, turn the oil filter counterclockwise to remove it. Tip the open end of the oil filter up to minimize oil spill.

MAINTENANCE

6. Clean the filter sealing surface on the engine crankcase with a clean rag and ensure the original oil filter o-ring is not stuck to the crankcase.

WARNING

Do not use a hose/pressure washer to clean up spilled oil on a vehicle. This may spread oil into surfaces that may get hot which may lead to a fire.

7. Lubricate the o-ring on the new oil filter with a film of clean engine oil. Check to make sure the o-ring is in good condition. Tighten to specification (Turn by hand until filter O-ring contacts sealing surface, then turn an additional 3/4 turn.)
8. Inspect the sealing washer on the drain plug for burrs or nicks. Replace the washer if it is damaged.
9. Reinstall the engine crankcase drain plug. Torque drain plug to specification [12 ft-lbs (16 Nm)].
10. Remove the cargo box. See the Service Access Panels section for details. Add engine oil through the oil fill cap  located on top of the engine valve cover.

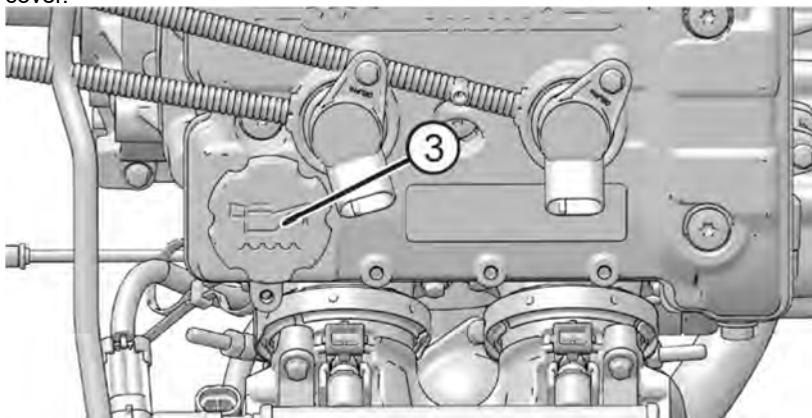

11. Fill the engine to the recommended specification.
12. Start engine and allow it to idle for 30 seconds.
13. Stop the engine and inspect for leaks. Wait at least 15 seconds before removing the oil dipstick.

14. Unlock the dipstick lever ④. Remove the dipstick and wipe it dry with a clean rag.

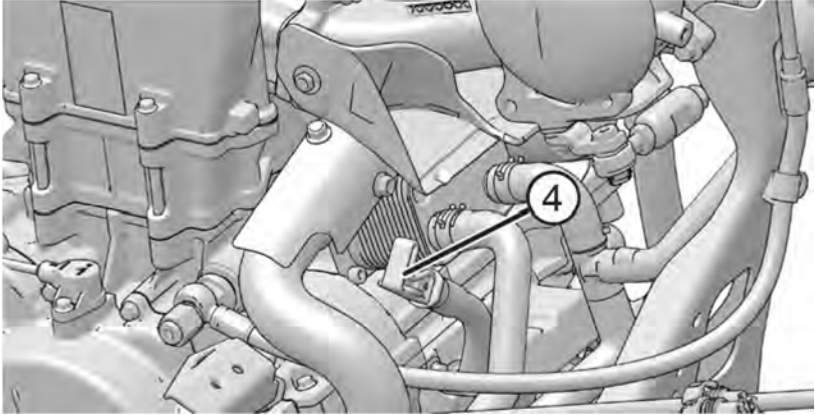

15. Reinstall the dipstick to fully seat it. Do not lock the dipstick.

NOTE

Make certain the dipstick is inserted all the way down to ensure an accurate reading.

16. Remove the dipstick and check the oil level.

17. Add the recommended oil as necessary to bring the oil level within the SAFE range (between the holes) on the dipstick. Do NOT overfill.

NOTE

A rising oil level between checks during cold weather operation can indicate contaminants such as gas or moisture collecting in the crankcase. If the oil level is over the upper mark, change the oil immediately.

18. When finished, reinstall dipstick and lock the lever.

19. Reinstall the cargo box.

20. Dispose of used oil, filter, and rags properly.

TRANSMISSION (MAIN GEARCASE)

Always check and change the fluid at the intervals outlined in the Periodic Maintenance Chart section. Refer to the Gearcase Specifications Chart section for recommended lubricants, capacities and torque specifications.

FLUID CHECK

The fill plug ① is located on the rear of the gearcase. Maintain the fluid level at the bottom of the fill plug hole.

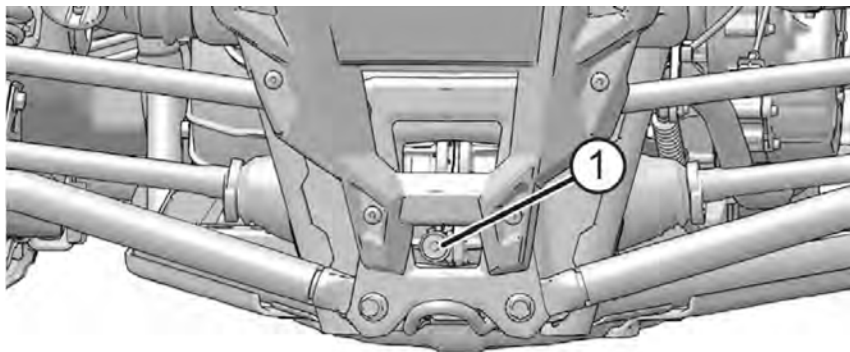

1. Position the vehicle on a level surface.
2. Remove the fill plug.
3. Check the fluid level.
4. Add the recommended fluid to the bottom of the fill plug hole. Do not overfill.
5. Reinstall the fill plug. Torque to specification.

FLUID CHANGE

The drain plug ① is located on the bottom of the gearcase. Access the drain plug through the drain hole in the skid plate.

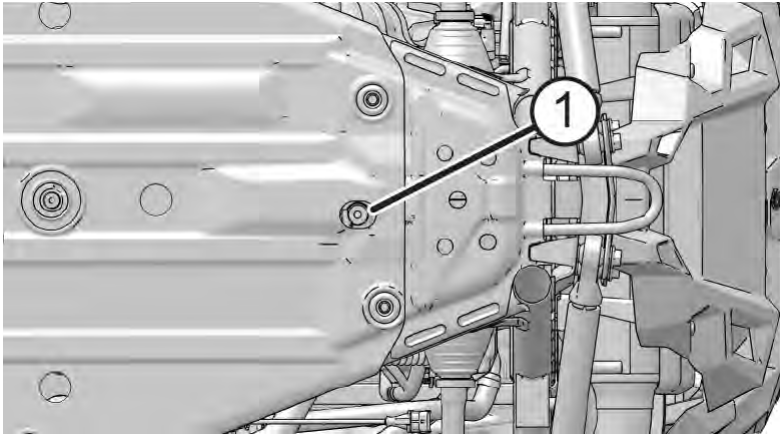

1. Remove the fill plug.
2. Place a drain pan under the drain plug.
3. Remove the drain plug. Allow the fluid to drain completely.
4. Clean the drain plug.
5. Reinstall the drain plug. Torque to specification (listed in the Gearcase Specification Chart of this manual).
6. Add the recommended fluid (listed in the Gearcase Specification Chart) to the bottom of the fill plug hole. Do not overfill.
7. Reinstall the fill plug. Torque to specification (listed in the Gearcase Specification Chart).
8. Check for leaks. Discard used fluid properly.

MAINTENANCE

DEMAND DRIVE UNIT (FRONT GEARCASE)

Always check and change the fluid at the intervals outlined in the Periodic Maintenance Chart section. Refer to the Gearcase Specifications Chart section for recommended lubricants, capacities and torque specifications.

Fill Plug Location

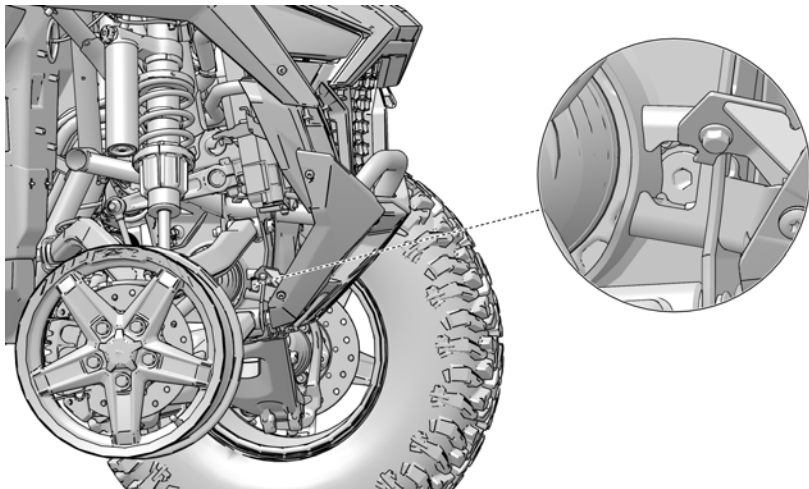

Drain Plug Location

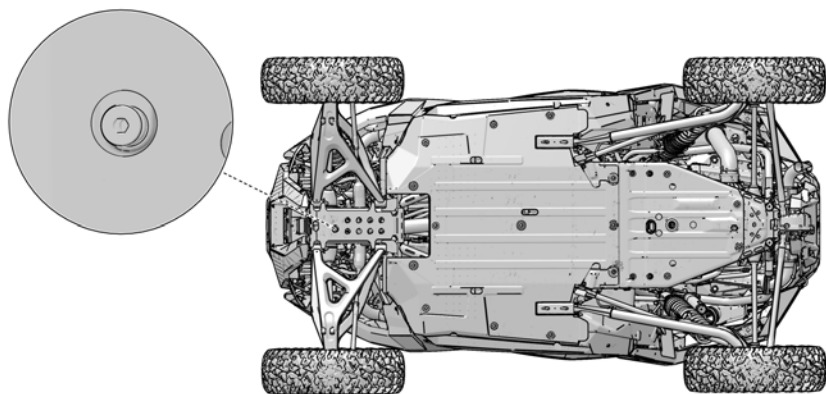

DEMAND DRIVE FLUID CHECK

The fill plug is located on the bottom right side of the demand drive unit. Maintain recommended fluid level at the bottom of the fill plug hole.

NOTE
See page 106 for demand drive unit torque and fluid specifications.

1. Position the vehicle on a level surface.
2. Remove the fill plug. Check the fluid level.
3. Add the recommended fluid.
4. Reinstall the fill plug. Torque to specification.

DEMAND DRIVE FLUID CHANGE

The demand drive drain plug is located on the bottom of the gearcase.

NOTE
See page 106 for demand drive unit torque and fluid specifications.

1. Remove the fill plug.
2. Place a drain pan under the drain plug.
3. Remove the drain plug. Allow the fluid to drain completely.
4. Clean the drain plug.
5. Reinstall the drain plug. Torque to specification.
6. Add the recommended fluid.
7. Reinstall the fill plug. Torque to specification.
8. Check for leaks. Discard used fluid properly and clean any excess oil residue.

MAINTENANCE

GEARCASE SPECIFICATION CHART

Use of other fluids may result in improper operation of components. See the Polaris Products section for the part numbers.

Gearcase	Lubricant	Capacity	Fill Plug Torque	Drain Plug Torque
Transmission (Main Gearcase)	AGL Gearcase Lubricant & Transmission Fluid	61 oz. (1800 ml)	10-14 ft. lbs. (14-19 N·m)	10-14 ft. lbs. (14-19 N·m)
Demand Drive Unit (Front Gearcase)	Demand Drive Fluid	9.47 oz. (280 ml)	8-10 ft. lbs. (11-14 N·m)	8-10 ft. lbs. (11-14 N·m)

SPARK PLUGS

SPARK PLUG GAP / TORQUE

Electrode Gap	Spark Plug Torque
0.7-0.8 mm	7 ft. lbs. (10 Nm)

NOTICE

Using non-recommended spark plugs can result in serious engine damage. Always use POLARIS-recommended spark plugs or their equivalent. Refer to the Specifications section for details.

Spark plug condition is indicative of engine operation. The spark plug firing end condition should be read after the engine is warmed up and the vehicle is driven at higher speeds. Immediately check the spark plug for correct color.

CAUTION

A hot exhaust system and engine can cause burns. Wear protective gloves when removing a spark plug for inspection.

SPARK PLUG REMOVAL AND REPLACEMENT

1. Remove the cargo box to access the spark plugs ①.

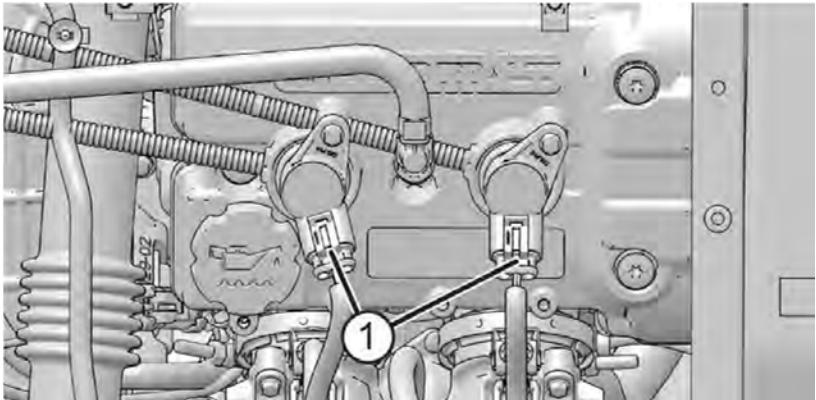

2. Clean the area around the spark plugs before removing the plugs. Unbolt the coils on the plugs.
3. Remove the coil assemblies.

MAINTENANCE

4. Using the spark plug wrench provided in the tool kit, remove the plugs by rotating them counterclockwise.
5. Reverse the procedure for spark plug installation. Torque to specification.

SPARK PLUG CONDITION

NORMAL PLUG

The normal insulator tip is gray, tan or light brown. There will be few combustion deposits. The electrodes are not burned or eroded. This indicates the proper type and heat range for the engine and the service.

NOTICE

The tip should not be white. A white insulator tip indicates overheating, caused by use of an improper spark plug or incorrect throttle body adjustments.

WET FOULED PLUG

The wet fouled insulator tip is black. A damp oil film covers the firing end. There may be a carbon layer over the entire nose. Generally, the electrodes are not worn. Fouling may be caused by excessive oil or by frequent short trips, especially in cold weather.

FUSE / RELAY CENTER

⚠ WARNING

Do not arrange fuses improperly or use replacement fuses with improper amperage values. This could lead to electrical overload, which can result in severe injury or death.

If the engine stops or will not start, if the power steering stops working (if equipped), or if you experience other electrical failures, a fuse may need replacement. Locate and correct any short circuits that may have caused the blown fuse, then replace the fuse.

There are two fuse/relay centers accessible on the vehicle. The primary fuse center ① is beneath the armrest and can be accessed by removing the bed of the armrest storage compartment.

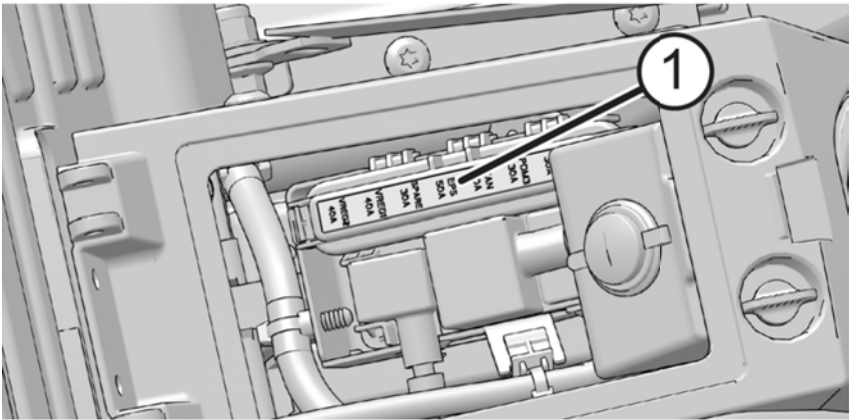

PRIMARY FUSE CENTER

LABEL	VALUE	FUNCTION
PDM 1	30A MCASE Fuse	Power to Secondary Fuse Center for Lights, Instrumentation, and Accessory Relay
PDM 2	30A MCASE Fuse	Power to Secondary Fuse Center for Auxiliary Outlets, Chassis, SCM, and Shock Fuse
PDM 3	30A MCASE Fuse	Power to Secondary Fuse Center for Fuel, LCAC, and EFI Fuse

MAINTENANCE

PRIMARY FUSE CENTER		
LABEL	VALUE	FUNCTION
FAN	30A MCASE Fuse	Engine Cooling Fan
EPS	50A MCASE Fuse	Electronic Power Steering
SPARE	30A MCASE Fuse	Spare fuse
VREG 1	40A MCASE Fuse	Voltage Regulator (Driver)
VREG 2	40A MCASE Fuse	Voltage Regulator (Passenger)
PULSE PWR	200A ZCASE Fuse	Battery Power to Polaris Pulse and 6AWG Cable

The secondary fuse center② is under the dash, near the operator's right knee area.

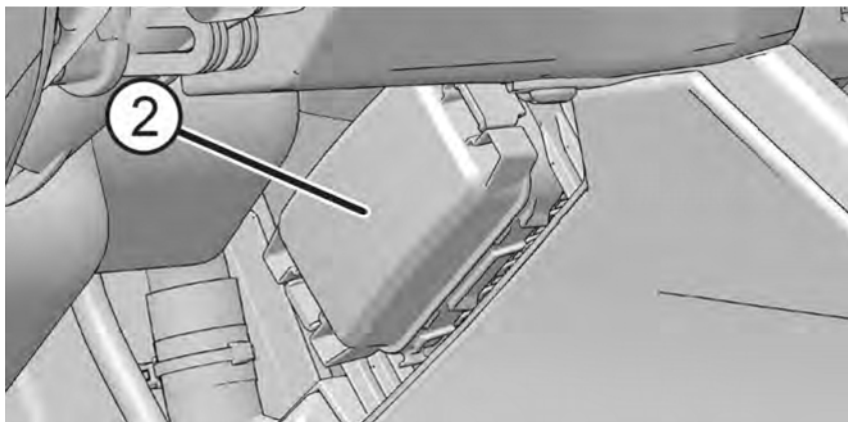

SECONDARY FUSE CENTER		
LABEL	VALUE	FUNCTION
LCAC	7.5A Fuse	Water Pump
FUEL	10A Fuse	Fuel Pump
TERM BLK	10A Fuse	Terminal Block Accessory

SECONDARY FUSE CENTER		
LABEL	VALUE	FUNCTION
INST ACCY	5A Fuse	Diagnostic Accessory, Interior LED Light, Display Accessory (optional)
PWR PT 1	10A Fuse	12V Socket (in front of gear selector)
INST UNSW	7.5A Fuse	Display (optional), Gauge, Diagnostic
LIGHTS	7.5A Fuse	Headlights, Taillights, Accent Lights (optional), Brake Lights
CHASSIS	7.5A Fuse	AWD Switch Light, Oxygen Sensor Heater, EPS Wake-Up, Vehicle Speed Sensor, Seat Belt Switch, SCM Wake-Up (optional), SCM Mode Switch (optional), AWD Coil, Gauge, Waste Gate
EFI	10A Fuse	Accessory Relay Coil, ECM Wake-Up, Pump Relay Coil, Chassis Relay Coil, Start Relay Coil, EFI Relay Coil, Injectors, SCM Relay Coil (optional), Lights Relay Coil, Ignition Coil, Starter Solenoid Coil, Brake Relay Coil
COIL	7.5A Fuse	Coil on Plug
CHARGE	15A Fuse	Charge Port
DYNAMIX Models		
SCM	10A Fuse	Shock Control Module
SHOCK	15A Fuse	Shock Power
AMP*	30A Fuse	Audio Amplifier
SUB*	40A Fuse	Audio Subwoofer

*For vehicles equipped with audio amplifiers and subwoofers, the fuses are located underneath the front storage compartment above the center console. Open the storage compartment and unlatch the four clips holding the storage tray in place to access the fuses③.

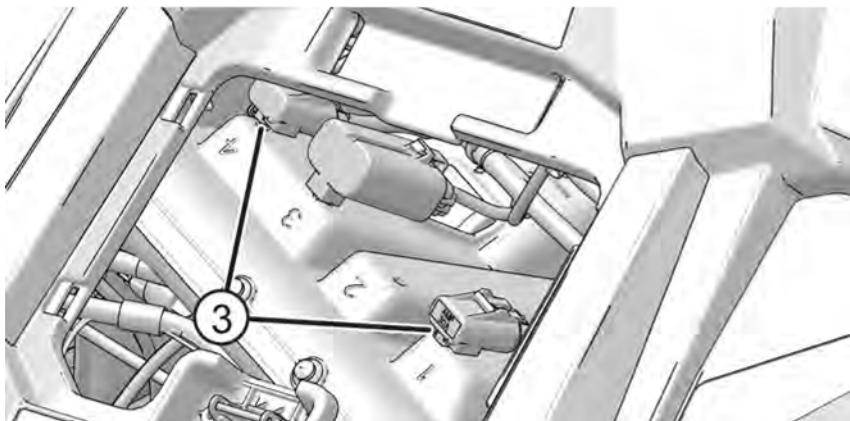

PDM FUSE TROUBLESHOOTING

IMPORTANT

In the event of faults or intermittent power to functions connected to more than just one fuse, a solution may be to replace one of the PDM fuses. This is because power routes from the PDM fuses to different “downstream” fuses. See the table below for details.

PDM FUSE	“DOWNSTREAM” FUSES
PDM 1 (30A)	INST UNSW (7.5A)
	LIGHTS (7.5A)
	INTR ACCY (10A)
	TREM BLK (10A)
PDM 2 (30A)	PWR PT1 (10A)
	CHASSIS (7.5A)
	SCM (10A)
	SHOCK (15A)
PDM 3 (30A)	EFI (10A)
	START (15A)
	FUEL (10A)

If you believe a PDM fuse may be causing intermittent power to its “downstream” fuses, follow the procedure for replacing and testing below.

1. Place the vehicle in PARK, turn off the engine, and then turn the ignition switch to the ON position.
2. Access the Primary Fuse Center in the driver-side rear wheel well.
3. Gently nudge the suspected PDM fuse by hand and check to see if intermittent power occurs to vehicle functions. This will simulate vehicle operation and help confirm which PDM is at issue. If intermittent power does not occur, perform the same nudge test on the remaining PDM fuses.
4. Once the correct PDM fuse is confirmed, turn the ignition switch to the OFF position.
5. Replace the PDM fuse using one of the SPARE fuses.

IMPORTANT

After removing a fuse, always check to ensure the two wire terminals that the fuse connects to are properly seated. Dislodged or misaligned wiring may also cause intermittent power to vehicle functions. If this is the case, adjust the wires by pushing up from the backside of the fuse block. If the problem persists, consult your dealer.

6. Turn the ignition switch to the ON position.
7. Gently nudge the SPARE fuse and check to see if intermittent power occurs to vehicle functions.

If power to vehicle functions appears consistent, the vehicle may resume operation. It is recommended that the vehicle be seen by a dealer for further assessment.

If power to vehicle functions remains inconsistent, do not operate the vehicle. Have the vehicle brought to a dealer immediately.

MAINTENANCE

COOLING SYSTEM

The engine coolant level is maintained by a remote pressurized tank system. The remote pressurized tank is connected to both radiators and provides a single pressure cap and fill point for the vehicle.

The pressure tank is designed to contain a volume of air above the coolant level. As coolant operating temperature increases the coolant level in the pressure tank will rise and push out air past the pressure cap. As the engine coolant temperature decreases the coolant level in the pressure tank will lower and draw air back into the tank through the pressure cap.

TIP

Some coolant level drop on new vehicles is normal as the system is purging itself of trapped air. Observe coolant levels and maintain cold coolant level as recommended by adding coolant to the pressure tank.

CAUTION

Escaping steam can cause burns. Never remove the pressure cap while the engine is warm or hot. Always allow the engine to cool before removing the pressure cap.

ADDING OR CHANGING COOLANT

POLARIS recommends the use of POLARIS Antifreeze 50/50 Premix. This antifreeze is already premixed and ready to use. Do not dilute with water. See the Polaris Products section for the part numbers.

To ensure that the coolant maintains its ability to protect the engine, we recommend that the system be completely drained every five (5) years and fresh Antifreeze 50/50 Premix added.

Any time the cooling system has been drained for maintenance or repair, replace the coolant with fresh Antifreeze 50/50 Premix.

RADIATORS AND COOLING FAN

Always check and clean the screens and radiator fins at the intervals outlined in the Periodic Maintenance Chart section. Do not obstruct or deflect air flow through the radiators by installing unauthorized accessories in front of the radiators or behind the cooling fan. Interference with radiator air flow can lead to overheating and consequent engine damage.

NOTICE

Washing the vehicle with a high-pressure hose could damage radiator fins and impair a radiator's effectiveness. Using a high-pressure system is not recommended.

RADIATOR COOLANT LEVEL / CHANGING COOLANT

The changing coolant procedure is required only if the cooling system has been drained for maintenance and/or repair. Ensure vehicle is parked on a level surface before servicing.

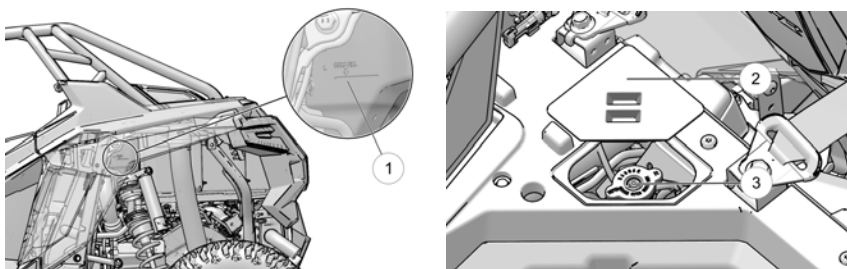

1. If only needing to check coolant level, there is a view ① from the driver-side rear fender. A flashlight may be needed. The coolant level can also be viewed by removing the cargo box.
2. To add coolant, begin by removing bottle access cover ② in rear of vehicle (driver-side).
3. Slowly remove the radiator pressure cap ③.
4. Remove the pressure cap and use a funnel to add coolant as needed. Maintain the coolant level at the cold fill mark on the side of the pressure tank (only when the fluid has cooled, if after operation).
5. Reinstall the pressure cap and the bottle access cover.

IMPORTANT

Use of a non-standard pressure cap will not allow the recovery system to function properly. Your authorized dealer can provide the correct replacement part.

IMPORTANT

If coolant must be added often, or if the pressure tank runs completely dry, there may be a leak in the system. Your authorized dealer can inspect the cooling system.

POLARIS VARIABLE TRANSMISSION (PVT) SYSTEM

WARNING

Failure to comply with the instructions in this warning can result in severe injury or death.

Do not modify any component of the PVT system. Doing so may reduce its strength so that a failure may occur at a high speed. The PVT system has been precision balanced. Any modification will cause the system to be out of balance, creating vibration and additional loads on components.

The PVT system rotates at high speeds, creating large amounts of force on clutch components. As the owner, you have the following responsibilities for your own safety and the safety of others:

- Always follow all recommended maintenance procedures. Always look for and remove debris inside and around the clutch and vent system when replacing the belt.
- See your dealer or other qualified service person as recommended in the owner's manual and on safety labels.
- This PVT system is intended for use on POLARIS products only. Do not install it in any other product.
- Always make sure the PVT housing is securely in place during operation.

Belt slip is responsible for creating excessive heat that destroys belts, wears clutch components and causes outer clutch covers to fail. Switch to low range while operating at slower speeds to extend the life of the PVT components (belt, cover, etc.).

BELT REPLACEMENT / DEBRIS REMOVAL

If a belt fails, always clean any debris from the outlet duct and from the clutch and engine compartments when replacing the belt.

⚠ WARNING

Failure to remove ALL debris when replacing the belt could result in vehicle damage, loss of control and severe injury or death.

1. Allow hot components to cool before performing this procedure.
2. Remove the engine access panel and thoroughly clean ALL debris from the engine compartment.

NOTE

If the vehicle is on solid ground, removal of the left rear wheel or shock is not necessary for belt replacement. If the vehicle is on a lift, the shock must be removed in order to remove the clutch cover.

3. Loosen the clamp ① retaining the PVT inlet duct to the outer clutch cover.
4. Remove the fourteen (14) clutch cover screws ②.

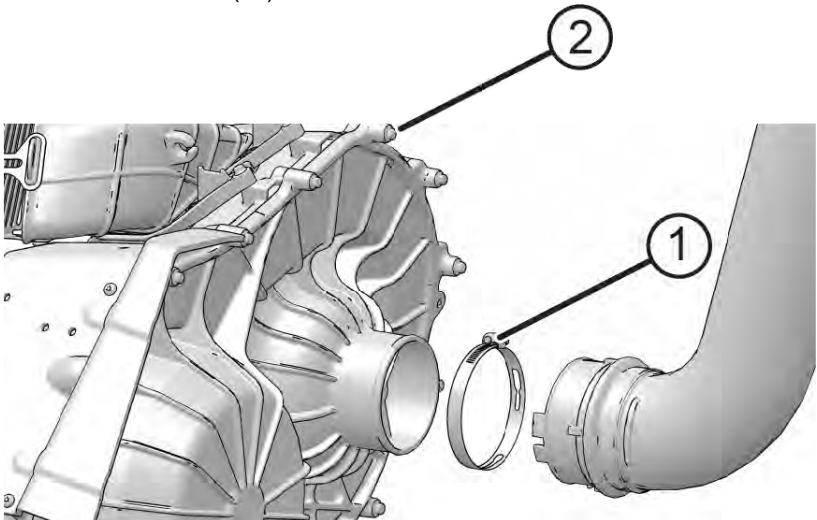

5. Maneuver the outer clutch cover outward to access the drive belt.
6. Mark the drive belt direction of rotation so that it can be installed in the same direction.

MAINTENANCE

7. Insert the clutch spreader tool ③ into the driven clutch. The tool is provided in the tool kit.

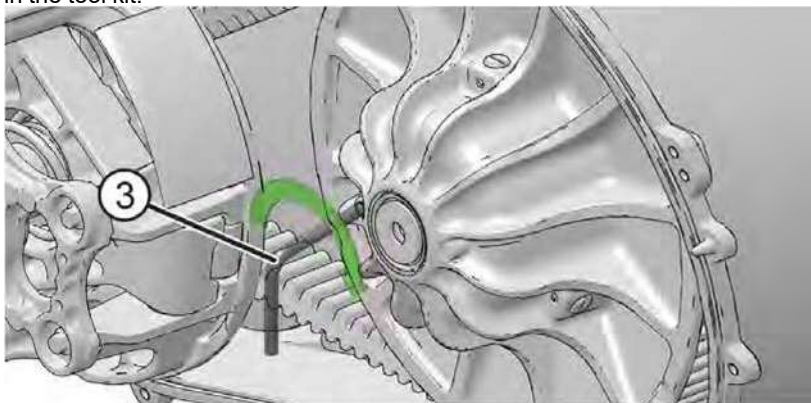

8. Turn the tool clockwise to open the sheaves on the driven clutch.
9. Walk the belt out of the driven and drive clutch. Remove the belt.
10. Remove **ALL** debris wrapped in and around the PVT system.
11. Remove **ALL** debris from the entire clutch air duct passage.
12. Check for signs of damage to seals on the transmission and engine. If any seals appear to be damaged, your vehicle requires prompt service. Your POLARIS dealer can assist.

TIP

Belt slip is responsible for creating excessive heat that destroys belts, wears clutch components and causes outer clutch covers to fail. Switch to low range while operating at slower speeds to extend the life of the PVT components (belt, cover, etc.). Prolonged operation with heavy loads or at high speeds can shorten belt life.

PVT DRYING

There may be some instances when water is accidentally ingested into the PVT system. Use the following instructions to dry it out before operating.

NOTICE

When washing the vehicle, always avoid spraying water directly toward the PVT intake duct. See the Washing the Vehicle section for details.

1. Remove the clutch cover drain plug.
2. Allow the water to drain. Reinstall the drain plug.
3. Place the transmission in PARK. Apply the brakes.
4. Start the engine.
5. Apply varying throttle for 10-15 seconds to expel the moisture and air-dry the belt and clutches. Do not hold the throttle wide open for more than 10 seconds.
6. Allow the engine RPM to settle to idle speed. Apply the brakes. Shift the transmission to the lowest available range.
7. Test for belt slippage. If the belt slips, repeat the process.
8. Your vehicle requires service as soon as possible. Your POLARIS dealer or authorized person can assist.

FILTER SYSTEMS

INTAKE PRE-FILTERS

The clutch air intake ① is located on the left side of the vehicle. The engine intake pre-filter ② is located on the right side of the vehicle.

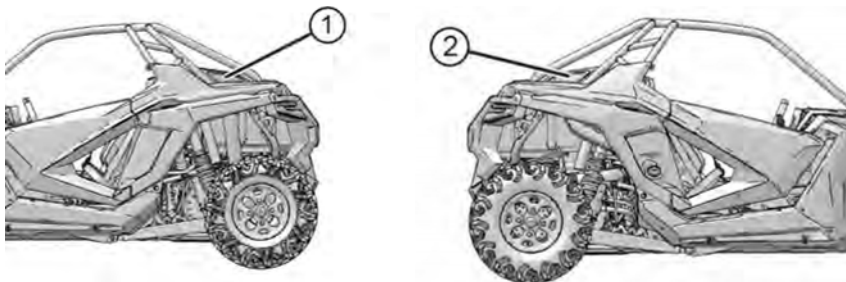

Inspect the engine pre-filter before each use of the vehicle to ensure adequate air flow. If necessary, remove the pre-filter and clean with soapy water. Dry with low pressure compressed air.

Periodically inspect the clutch (PVT) air intake for debris and clean as needed to ensure adequate air flow.

TIP

When washing the vehicle, always avoid spraying water directly toward the PVT intake. If water is sprayed into the PVT intake, follow the procedures in the PVT Drying section. See the Washing the Vehicle section for recommended washing procedures.

AIR FILTER

WARNING

Be sure to replace all vehicle components as before once finished servicing the air filter. Improper thermal protection creates a fire hazard and can lead to injury or death.

Always change the air filter at the intervals outlined in the Periodic Maintenance Chart.

1. Remove the close-off panel between the seats.
2. Clean all dirt and debris from the air box area.
3. Unlatch the five (5) air box cover clips  and carefully remove the air box cover.

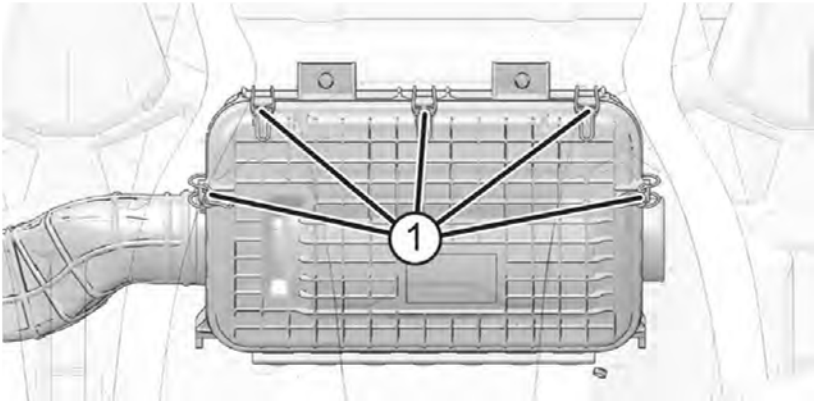

4. Inspect the air filter  and air box for dirt, debris or water.

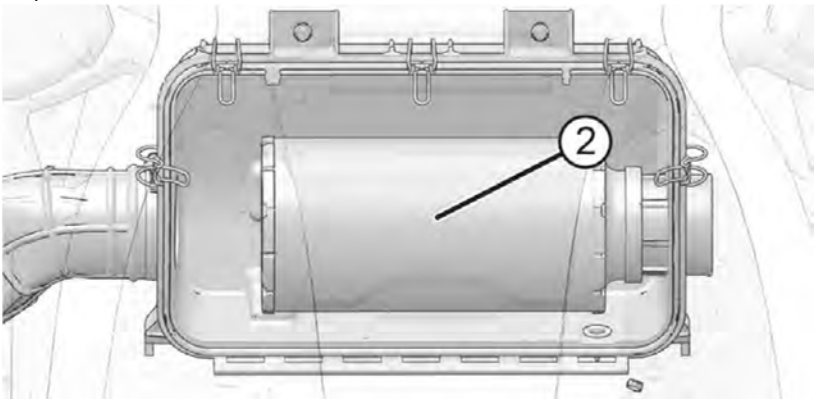

MAINTENANCE

5. To remove the filter, slide the filter toward the passenger's side of the vehicle.
6. With the filter removed, clean the intake tube and air box thoroughly. Wipe well with a clean, dry cloth.

NOTICE

Dirt or debris in the intake tube could result in severe engine damage. Always clean all dirt and debris from the intake tube before installing the filter.

7. Reinstall the air filter (if clean) or install a new air filter (if soiled). Do not attempt to clean the air filter.

NOTICE

Use of a non-POLARIS-approved air filter may cause engine damage. Always use a POLARIS-approved replacement filter. Replacement filters are available at your POLARIS dealer.

8. Make sure that there are no gaps between the filter, the filter ring and the stop on the intake tube.
9. Reinstall the air box cover and ensure the alignment tabs are properly positioned.
10. Secure the five (5) cover clips.
11. Reinstall the close-off panel.

SPARK ARRESTER

WARNING

- Never operate the vehicle without the spark arrester.
- Remove any combustible materials from the area.

Failure to heed the following warnings while servicing the spark arrester could result in serious injury or death.

- Never run the engine in an enclosed area. Exhaust contains poisonous carbon monoxide gas that can cause loss of consciousness or death in a very short time.
- Do NOT perform service on the spark arrester while the system is HOT. Exhaust system temperatures can reach extreme temperatures. Allow components to cool sufficiently before proceeding.
- Do not stand behind or in front of the vehicle while purging the exhaust system.
- Never go under the vehicle while it is inclined.
- Wear eye protection and gloves while servicing.

Periodically clean the spark arrester to remove accumulated carbon. A plugged spark arrester will affect engine performance. Clean daily when driving in mud and water. Replace a cracked or damaged arrester before operating.

1. Remove the arrester retaining bolt ① and nut ②.
2. Remove the arrester from the end of the muffler ③.
3. Use a non-synthetic brush to clean the arrester screen ④. A synthetic brush may melt if components are warm. If necessary, blow debris from the screen with compressed air.



4. Inspect the screen for wear and damage. Replace a worn or damaged screen.
5. Reinstall the arrester. Torque bolt to 7-9 ft. lbs. (9-12 Nm).

BRAKES

 **WARNING**

Operating the vehicle with a spongy brake pedal can result in loss of braking, which could cause an accident resulting in severe injury or death. Never operate the vehicle with a spongy-feeling brake pedal.

The front and rear brakes are hydraulic disc type brakes activated by the brake pedal.

 **CAUTION**

Brake discs can become extremely hot after operation. Allow the discs to cool before performing maintenance to prevent risk of burns.

Always check brake pedal travel and the brake fluid reservoir level before each use of the vehicle. When applied, the brake pedal should feel firm. Any sponginess would indicate a possible fluid leak or low brake fluid level, which must be corrected before riding. See the Brake Fluid section for further details.

If you discover any irregularities in brake system operation, including excessive pedal travel, contact your dealer for proper diagnosis and repairs.

BRAKE INSPECTION

WARNING

Do not apply WD-40® or any petroleum product to brake discs. These types of products are flammable and may also reduce the friction between the brake pad and caliper.

1. Check the brake system for fluid leaks.
2. Check the brake pedal for excessive travel or a spongy feel.
3. Check the friction pads for wear, damage and looseness.
4. Check brake discs for signs of cracks, excessive corrosion, warping or other damage. Clean any grease using an approved brake cleaner or alcohol.
5. Inspect the brake disc pad wear surface ① for excessive wear. Change pads when worn to 0.030" (0.762 mm) .

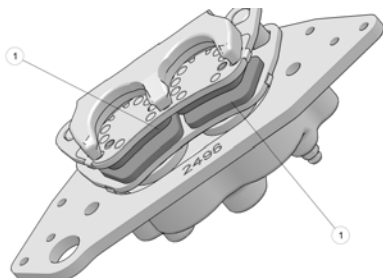

BRAKE FLUID

WARNING

After opening a bottle of brake fluid, always discard any unused portion. Never store or use a partial bottle. Brake fluid is hygroscopic, meaning it rapidly absorbs moisture from the air. The moisture causes the boiling temperature of the brake fluid to drop, which can lead to early brake fade and the possibility of accident or severe injury.

Inspect the level of the brake fluid before each operation. If the fluid level is low add DOT 4 brake fluid only. See the Polaris Products section for the part numbers. Change the brake fluid every two years and any time the fluid becomes contaminated, the fluid level is below the minimum, or if the type and brand of the fluid in the reservoir are unknown. Access the brake fluid reservoir through the left front wheel well.

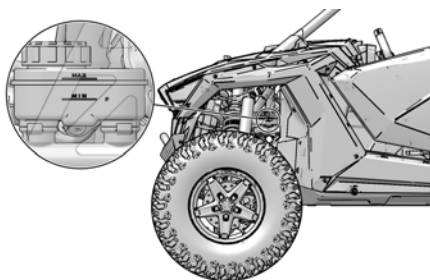

1. Position the vehicle on a level surface.
2. Place the transmission in PARK.
3. View the brake fluid level in the reservoir. The level should be between the maximum and minimum level lines.
4. If the fluid level is lower than the lower level line, add brake fluid to the upper line.
5. Apply the brake forcefully for a few seconds and check for fluid leakage around the fittings.

SUSPENSION SETTINGS



WARNING

Shock absorber assemblies contain nitrogen gas under high pressure and can explode if punctured or exposed to flame or heat. Follow maintenance, care, and disposal instructions from the manufacturer of the shock absorber.

PRELOAD SETTINGS

Adjusting preload settings can alter vehicle handling.

IMPORTANT

Never exceed the MAX allowable preload when adjusting the suspension. Damage to the suspension system may occur if the MAX allowable preload is exceeded.

RZR TURBO R		FACTORY DEFAULT PRELOAD SETTINGS		MAX ALLOWABLE PRELOAD	
	Measurement*	Fox®	Walker Evans Racing®	Fox®	Walker Evans Racing®
Front Shocks	①	0.350 in. (0.89 cm)	0.563 in. (1.4 cm)	1.350 in. (3.4 cm)	1.563 in. (4.0 cm)
	②	2.900 in. (7.4 cm)	2.500 in. (6.4 cm)	2.900 in. (7.4 cm)	2.500 in. (6.4 cm)
Rear Shocks	①	6.335 in. (16.1 cm)	1.685 in. (4.3 cm)	7.335 in. (18.6 cm)	2.685 in. (6.8 cm)
	②	3.250 in. (8.3 cm)	3.750 in. (9.5 cm)	3.250 in. (8.3 cm)	3.750 in. (9.5 cm)

*See the images in the Front / Rear Spring Preload Adjustment section to view corresponding preload measurement locations

MAINTENANCE

RZR TURBO R 4		FACTORY DEFAULT PRELOAD SETTINGS		MAX ALLOWABLE PRELOAD	
	Measurement*	Fox®	Walker Evans Racing®	Fox®	Walker Evans Racing®
Front Shocks	①	3.563 in. (9.1 cm)	1.382 in. (3.5 cm)	4.563 in. (11.6 cm)	2.382 in. (6.1 cm)
	②	2.875 in. (7.3 cm)	3.000 in. (7.6 cm)	2.875 in. (7.3 cm)	3.000 in. (7.6 cm)
Rear Shocks	①	6.650 in. (16.9 cm)	1.375 in. (3.5 cm)	7.650 in. (19.4 cm)	2.375 in. (6.0 cm)
	②	3.625 in. (9.2 cm)	4.375 in. (11.1 cm)	3.625 in. (9.2 cm)	4.375 in. (11.1 cm)
*See the images in the Front / Rear Spring Preload Adjustment section to view corresponding preload measurement locations					

FOX® SHOCKS (IF EQUIPPED)

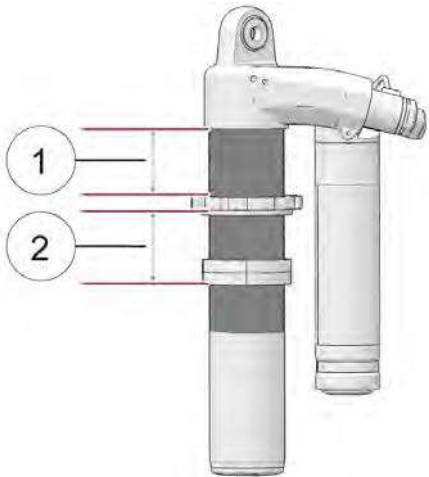
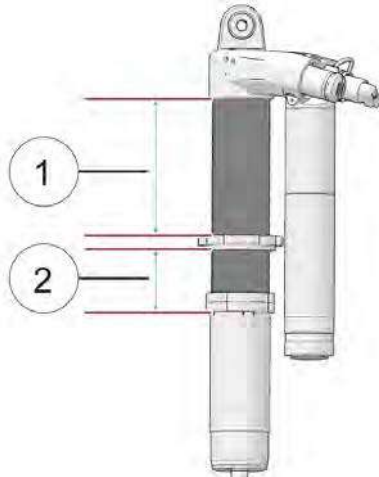
SHOCK LOCATION	MEASUREMENT*
<p>Front Shock</p>	 <p>The diagram shows a FOX front shock with two measurement points indicated by red lines and circles. Point 1 is the distance from the top mounting eye to the top of the shock body. Point 2 is the distance from the top of the shock body to the bottom of the shock body. A second shock is shown to the right for comparison.</p>
<p>Rear Shock</p>	 <p>The diagram shows a FOX rear shock with two measurement points indicated by red lines and circles. Point 1 is the distance from the top mounting eye to the top of the shock body. Point 2 is the distance from the top of the shock body to the bottom of the shock body. A second shock is shown to the right for comparison.</p>

MAINTENANCE

WALKER EVANS RACING® SHOCKS (IF EQUIPPED)

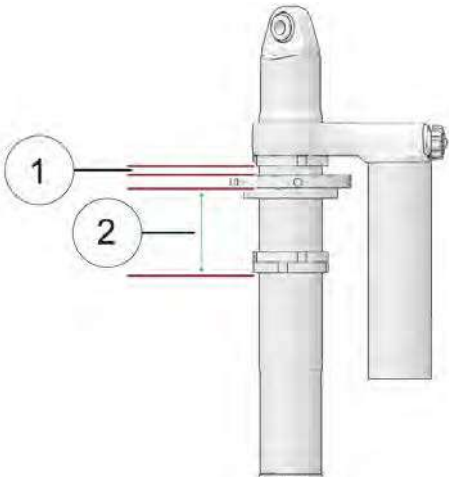
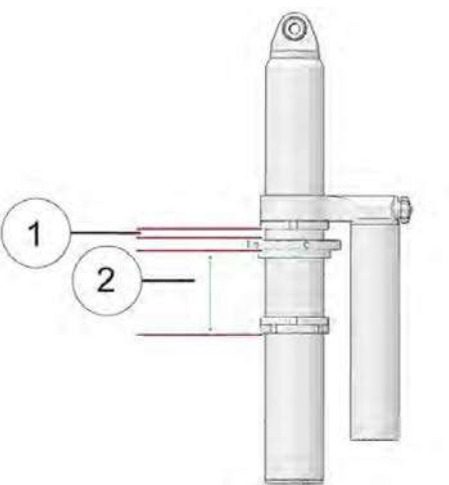
SHOCK LOCATION	MEASUREMENT*
Front Shock	 <p>The diagram shows a front shock absorber assembly. Two horizontal red lines, labeled '1', indicate the measurement points for the upper spring plate. A vertical dimension line, labeled '2', indicates the distance between the upper and lower spring plates.</p>
Rear Shock	 <p>The diagram shows a rear shock absorber assembly. Two horizontal red lines, labeled '1', indicate the measurement points for the upper spring plate. A vertical dimension line, labeled '2', indicates the distance between the upper and lower spring plates.</p>

FRONT / REAR SPRING PRELOAD ADJUSTMENT

The factory setting is appropriate for nearly all riding conditions. If desired, the suspension may be adjusted to maintain vehicle clearance height when carrying loads. Adjusting the suspension may change vehicle handling.

IMPORTANT

The distance between the main preload ring (top ring) and the cross-over rings (middle rings) should be constant. If you move the main preload ring, you will need to move the cross-over rings an equal amount. The cross-over rings need to be locked tight after any adjustment is made. To lock the cross-over rings, take a punch and hammer to hit each side so the rings jam together. If the cross-over rings are not locked down tight, damage to the shock may occur.

To adjust the preload, do the following:

1. Elevate the vehicle to allow the suspension to fully extend.
2. Turn the adjusting ring to the left to add preload. Turn the adjusting ring to the right to remove preload.

Uneven adjustment may cause poor handling of the vehicle. Always adjust both the left and right spring preloads equally or have your POLARIS dealer or qualified person perform the adjustments.

MAINTENANCE

FRONT / REAR SHOCK COMPRESSION ADJUSTMENT (NON-DYNAMIX VEHICLES)

The compression damping clicker knob is located at the top of the shock reservoir.

1. Turn the clicker **clockwise** to **increase** compression damping.
2. Turn the clicker **counter-clockwise** to **decrease** compression damping.

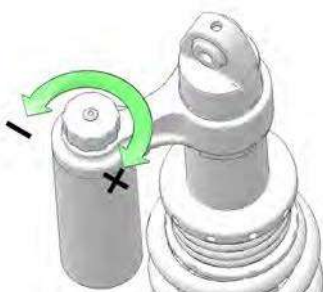

LOCATION	DEFAULT CLICKER POSITION
Front	8/16 clicks
Rear	8/16 clicks

SPRING PRELOAD ADJUSTMENT RECOMMENDATIONS

⚠ WARNING

Be advised that the shocks contain nitrogen at high pressure. Damaged shocks could cause injury if not replaced or addressed promptly by qualified personnel.

IMPORTANT

Never exceed the MAX allowable preload when adjusting the suspension. Damage to the suspension system may occur if the MAX allowable preload is exceeded. See page 127 for details.

SPRING PRELOAD ADJUSTMENT RECOMMENDATIONS

RZR Turbo R and RZR Turbo R 4

Axle	Preload
Front*	+ 0.75 inches per 100 lbs. added (+1.9 cm per 45 kg added)
Rear*	+ 0.63 inches per 100 lbs. added (+1.6 cm per 45 kg added)

*If weight is added to center of vehicle, split preload accordingly between front and rear axles.

TIRES

WARNING

Operating your vehicle with worn tires will increase the possibility of skidding, loss of control and an accident, which could result in serious injury or death. Always replace tires when the tread depth measures 1/8 in (3 mm) or less.

Improper tire inflation or the use of non-standard size or type of tires may adversely affect vehicle handling, which could result in vehicle damage or personal injury. Always maintain proper tire pressure. Always use POLARIS-approved size and type of tires for this vehicle when replacing tires.

Tires age even if they have not been used or have only been used occasionally. Cracking of the tread and sidewall rubber and/or deformation is evidence of aging. Tires should be inspected for aging before use. If signs of aging or damage are found, see your Polaris dealer or other qualified person for assistance.

TIRE TREAD DEPTH

Always replace tires when tread depth is worn to 1/8 in (3 mm) ① or less.

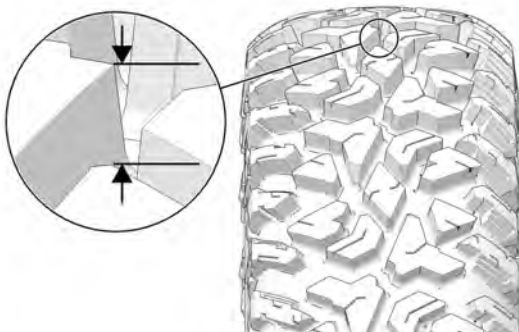

TIRE ROTATION

Tire rotation is recommended for every 500-mile (805-km) interval. Perform tire rotation on the vehicle by the strategy as shown.

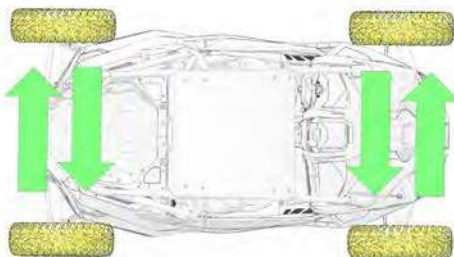

AXLE AND WHEEL NUT TORQUE SPECIFICATIONS

Inspect the following items occasionally for tightness, and if they've been loosened for maintenance service. *Do not lubricate the stud or the lug nut.*

Lug Nut (Aluminum Wheels)	Front and Rear	148 ft-lbs (200 N·m)
Hub Retaining Nut	Front and Rear	89 ft-lbs (120 N·m)

WHEEL REMOVAL

1. Position the vehicle on a level surface.
2. Place the transmission in PARK.

NOTE

After a ride, allow the engine to idle for 30 seconds before stopping the engine. This will allow the turbo system to cool down.

3. Stop the engine.
4. Loosen the wheel nuts slightly.
5. Elevate the side of the vehicle by placing a suitable stand under the frame.
6. Remove the wheel lug nuts. Remove the wheel.

WHEEL INSTALLATION

1. Place the wheel in the correct position on the wheel hub. Be sure the valve stem ① is toward the outside and rotation arrows on the tire point toward forward rotation.
2. Attach the wheel nuts and finger tighten.
3. Carefully lower the vehicle to the ground.
4. Torque the wheel nuts to specification in a crisscross pattern. See the Axle and Wheel Nut Torque Specifications section for details.

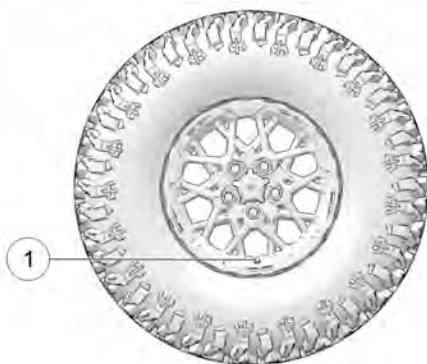

LIGHTS

Headlight and taillight lenses become dirty during normal operation. Clean all lights frequently to ensure a clear field of vision as well as visibility to other vehicles.

TIP

LED LAMPS

If an LED headlamp appears to have moisture or fogging *inside* the lens, disconnect the wiring harness from the headlamp(s) for a few days to allow the moisture to clear out.

TIP

HALOGEN LAMPS

When servicing a halogen lamp, don't touch the lamp with bare fingers. Oil from your skin leaves a residue, causing a hot spot that will shorten the life of the lamp.

TAILLIGHT / BRAKE LIGHT REPLACEMENT

The taillight assembly is not serviceable. If the taillight or brake light fails to operate properly, replace the entire taillight assembly.

HEADLIGHT REPLACEMENT

If a headlight becomes damaged or inoperable, the entire headlight assembly must be replaced. Do not operate this vehicle at night or in low light conditions until the headlight is replaced. Always make sure lights are adjusted properly for best visibility.

MAINTENANCE

HEADLIGHT BEAM ADJUSTMENT

The headlight beam can be adjusted slightly upward or downward and to the left or right.

1. Position the vehicle on a level surface. The headlight should be approximately 25 ft. (7.6 m) from a wall.

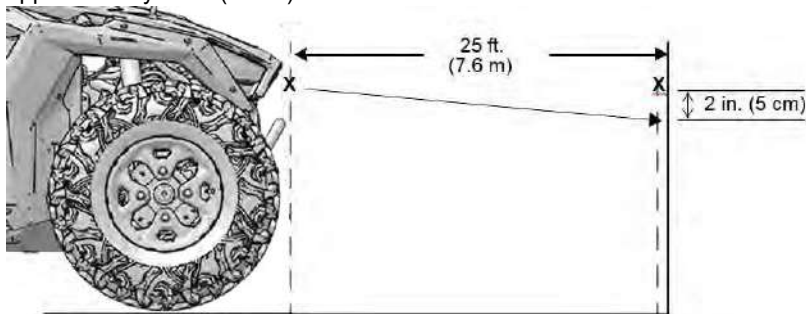

2. Place the transmission in PARK.
3. Measure the distance from the floor to the center of the headlight and make a mark on the wall at the same height.
4. Apply the brakes. Start the engine. Turn the headlights to high beam.
5. Include the weight of a rider on the seat while performing this step. Observe the headlight aim. As a starting point, the most intense part of the headlight beam should be 2 inches (5 cm) below the mark on the wall. Adjust to operator preference.
6. Tighten or loosen the two (2) headlight screws ① to adjust the beam upward or downward or to the left or right.



VEHICLE IMMERSION

NOTICE

If your vehicle becomes immersed, major engine damage can result if the machine is not thoroughly inspected. Take the vehicle in for service before starting the engine. Your POLARIS dealer can provide this service.

If it's impossible to take your vehicle to a dealer before starting it, follow the steps outlined below.

1. Move the vehicle to dry land.
2. Check the air box. See the Air Filter section for details. If water is present, dry the air box and replace the filter with a new filter.
3. Remove the fuse/relay center cover. See the Fuse/Relay Center section for details. Allow any moisture to dry, then reinstall the cover.
4. Dry the spark plug wells with a clean cloth, then remove the spark plugs.
5. Turn the engine over several times to expel any water from the engine cylinders.
6. Dry the spark plugs and reinstall them, or install new plugs.
7. Attempt to start the engine. If necessary, repeat the drying procedure.
8. Take the vehicle in for service as soon as possible, whether you succeed in starting it or not. Your POLARIS dealer can provide the required service.
9. If water has been ingested into the PVT follow the steps in the POLARIS Variable Transmission (PVT) System section for drying procedures.

STEERING WHEEL INSPECTION

Check the steering wheel for specified freeplay and smooth operation at the intervals outlined in the Periodic Maintenance Chart.

1. Position the vehicle on level ground.
2. Lightly turn the steering wheel left and right.
3. There should be 0.8-1.0 in (20-25 mm) of freeplay.
4. If there is excessive freeplay or strange noises, or if the steering feels rough or "catchy," have the steering system inspected by an authorized POLARIS dealer or other qualified personnel.

BATTERY

WARNING

Improperly connecting or disconnecting battery cables can result in an explosion and cause serious injury or death. When removing the battery, always disconnect the negative (black) cable first. When reinstalling the battery, always connect the negative (black) cable last.

Your vehicle has a low-maintenance battery. Always keep battery terminals and connections free of corrosion. If cleaning is necessary, remove the corrosion with a stiff wire brush. Wash with a solution of one tablespoon baking soda and one cup water. Rinse well with tap water and dry off with clean shop towels. Coat the terminals with dielectric grease or petroleum jelly.

NOTE

If more amperage is required for high electrical loads, an additional battery can be added.

BATTERY REMOVAL

1. Ensure the key switch is set to OFF position before removing the battery.
2. Remove the driver's seat. See the Seats section for details.
3. Disconnect the black (negative) battery cable first, and secure away from the battery terminals.
4. Disconnect the red (positive) battery cable last.
5. Remove the battery hold-down strap.
6. Lift the battery out of the vehicle.

BATTERY INSTALLATION

Using a new battery that has not been fully charged can damage the battery and result in a shorter life. It can also hinder vehicle performance. Follow the instructions in the Battery Charging section before installing the battery.

1. Ensure that the battery is fully charged.
2. Place the battery in the battery holder.
3. Coat the terminals with dielectric grease or petroleum jelly.
4. Secure the battery hold-down strap.
5. Connect and tighten the red (positive) cable first.
6. Connect and tighten the black (negative) cable last.

7. Verify that cables are properly routed.
8. Reinstall the seat.

BATTERY MAINTENANCE AND CHARGING

WARNING

An overheated battery may explode, causing severe injury or death. Always watch charging times carefully. Stop charging if the battery becomes very warm to the touch. Allow it to cool before resuming charging.

WARNING

The sealed battery is already filled with electrolyte and has been sealed and *fully charged* at the factory. *Never* pry the sealing strip off or add any other fluid to this battery. It contains sulfuric acid. Serious burns can result from contact with skin, eyes, or clothing.

The single most important thing about maintaining a sealed battery is to keep it fully charged. Check the battery voltage with a voltmeter or multimeter. A fully charged battery will register 12.8 V or higher. If the voltage falls below 12.5V, charge it immediately, or the battery runs the risk of sulfation and reduced battery life.

This vehicle is equipped with a vehicle battery charge port located on the dash. This allows the operator to charge the vehicle battery without needing to access the battery under the driver's seat.

If you do not drive the vehicle for more than TWO WEEKS, Polaris recommends using a BatteryMINDER® 2012 AGM - 2 AMP charger (PN 2830438), which can be ordered through your dealer.



If you plan to store the vehicle for ONE MONTH or longer, remove the battery from the vehicle, then store the battery in a cool and dry location. Continue to maintain the battery with the BatteryMINDER® 2012 AGM - 2 AMP charger.

When using an automatic charger other than a BatteryMINDER® 2012-AGM - 2 AMP charger, refer to the charger manufacturer's instructions for recharging.

MAINTENANCE

USING A CONSTANT CURRENT CHARGER

If you are using a **constant current charger** (instead of BatteryMINDER® 2012 AGM - 2 AMP charger), use the guidelines below. Always verify battery condition before and 1-2 hours after the end of charging.

State of Charge	Voltage (DC)	Action	Charge Time*
100%	12.8-13.0 volts	None, check monthly	None required
75%-100%	12.6-12.8 volts	May need slight charge, if no charge given, check in 2 weeks	3-6 hours
50%-75%	12.3-12.6 volts	Needs charge	5-11 hours
25%-50%	12.0-12.3 volts	Needs charge	At least 13 hours
0%-25%	12.0 volts or less	Needs charge	At least 20 hours

* Using AGM specific charger at standard amps specified on top of battery

CLEANING AND STORAGE

WASHING THE VEHICLE

Keeping your POLARIS vehicle clean will not only improve its appearance but it can also extend the life of various components.

NOTE

All sealed storage compartments in the vehicle are element-resistant but not water-proof. Remove items from storage compartments before cleaning to avoid water damage.

NOTICE

Water in the PVT system could cause the drive belt to become wet and slip in the clutches. Always avoid spraying water directly toward any intake pre-filters^①. If water is sprayed into the pre-filters, perform the drying procedures described in the PVT Drying section.

High water pressure may damage radiator fins and impair a radiator's effectiveness. High pressure may also damage other vehicle components.

Certain products, including insect repellents and chemicals, will damage plastic surfaces. Do not allow these types of products to contact the vehicle.



The best and safest way to clean your POLARIS vehicle is with a garden hose and a pail of mild soap and water.

1. Use a professional-type washing cloth, cleaning the upper body first and the lower parts last.
2. Rinse with clean water frequently.
3. Dry surfaces with a chamois to prevent water spots.

MAINTENANCE

If a high pressure water system is used for cleaning (not recommended), exercise extreme caution. The water may damage components and could remove paint and labels. Avoid directing the water stream at the following items:

- Wheel bearings
- Radiators
- Transmission seals
- Brakes
- Cab and body panels
- Labels and decals
- Electrical components and wiring
- Air intake components

If warning and safety labels are damaged, contact your POLARIS dealer for free replacement.

Grease all zerk fittings immediately after washing. Allow the engine to run for a while to evaporate any water that may have entered the engine or exhaust system.

WASHING TIPS

- Avoid the use of harsh cleaners, which can scratch the finish.
- Do not use a power washer to clean the vehicle.
- Do not use medium to heavy duty compounds on the finish.
- Always use clean cloths and pads for cleaning and polishing. Old or reused cloths and pads may contain dirt particles that will scratch the finish.

POLISHING THE VEHICLE

POLARIS recommends the use of common household aerosol furniture polish for polishing the finish on your POLARIS vehicle. Follow the instructions on the container.

POLISHING TIPS

- Avoid the use of automotive products, some of which can scratch the finish of your vehicle.
- Always use clean cloths and pads for cleaning and polishing. Old or reused cloths and pads may contain dirt particles that will scratch the finish.
- Avoid the use of products containing a colorant dye. Test any products on an inconspicuous area of the vehicle before using throughout.

STORAGE TIPS

NOTICE

Starting the engine during the storage period will disturb the protective film created by fogging and damage could occur. Never start the engine during the storage period.

CLEAN THE EXTERIOR

Make any necessary repairs and clean the vehicle as recommended. See the Washing the Vehicle section for details.

STABILIZE THE FUEL

1. Fill the fuel tank.
2. Add POLARIS Carbon Clean Fuel Treatment or POLARIS Fuel Stabilizer or equivalent fuel treatments or stabilizers. Follow the instructions on the container for the recommended amount. Carbon Clean removes water from fuel systems, stabilizes fuel and removes carbon deposits from pistons, rings, valves and exhaust systems.
3. Allow the engine to run for 15-20 minutes to allow the stabilizer to disperse through the entire fuel delivery system.

OIL AND FILTER

Change the oil and filter. See the Oil and Filter Change section for details.

AIR FILTER / AIR BOX

Replace the air filter. See the Air Filter section for details. Clean the air box.

FLUID LEVELS

Inspect the fluid levels. Add or change fluids as recommended in the Periodic Maintenance Chart section.

- Demand drive fluid (front gearcase)
- Rear gearcase fluid (if equipped)
- Transmission fluid
- Brake fluid (change every two years and any time the fluid looks dark or contaminated)
- Coolant (test strength/fill)

INSPECT AND LUBRICATE

Inspect all cables and lubricate all areas of the vehicle as recommended in the Periodic Maintenance Chart section.

MAINTENANCE

FOG THE ENGINE

1. Treat the fuel system with POLARIS Carbon Clean or other equivalent fuel treatment. Follow the instructions on the container. Start the engine. Allow it to idle for several minutes so the Carbon Clean reaches the injectors. Stop the engine.
2. Remove the spark plugs and add 2-3 tablespoons of engine oil. To access the plug holes, use a section of clear 1/4" hose and a small plastic squeeze bottle filled with the pre-measured amount of oil. *Do this carefully! If you miss the plug holes, oil will drain from the spark plug cavities into the hole at the front of the cylinder head, and appear to be an oil leak.*
3. Reinstall the spark plugs. Torque to specification. See the Spark Plug Gap / Torque section for details.
4. Apply dielectric grease to the inside of each spark plug cap. *Do not reinstall the caps onto the plugs at this step.*
5. Turn the engine over several times. Oil will be forced in and around the piston rings and ring lands, coating the cylinder with a protective film of fresh oil.
6. If POLARIS fuel system additive is not used, fuel tank, fuel lines, and injectors should be completely drained of gasoline.
7. Reinstall the spark plug caps to the spark plugs.

BATTERY MAINTENANCE

See Battery section for storage and charging procedures.

FUSE BOX

Remove the fuse box cover during storage.

STORAGE AREA / COVERS

Be sure the storage area is well ventilated. Cover the vehicle with a genuine POLARIS cover. Do not use plastic or coated materials. They do not allow enough ventilation to prevent condensation, and may promote corrosion and oxidation.

REMOVAL FROM STORAGE

1. Charge the battery if necessary.
2. Make sure the spark plug is tight. Reinstall the fuse box cover if it was removed for storage.
3. Fill the fuel tank with fuel.

4. Check all the points listed in the Daily Pre-Ride Inspection section. Tightness of the bolts, nuts and other fasteners should be checked by an authorized POLARIS dealer or other qualified service facility.
5. Lubricate at the intervals outlined in the Periodic Maintenance Chart section.

 **WARNING**

Engine exhaust contains poisonous carbon monoxide and can cause loss of consciousness or death. Never run an engine in an enclosed area.

TRANSPORTING THE VEHICLE

WARNING

Cargo and other loose vehicle parts may fly off while transporting this vehicle. Secure or remove all cargo, and inspect the unit for loose parts prior to transport.

If transporting the vehicle in a non-enclosed trailer, then the vehicle must FACE FORWARD, or roof must be removed.

Failure to comply may allow airflow, vibration, or other factors to separate the roof from the vehicle and cause an accident, resulting in serious personal injury or death.

NOTE

For functional descriptions detailing how to operate the DYNAMIX suspension system on certain vehicle models, consult the Polaris *RideCommand* manual.

Follow these procedures when transporting the vehicle.

NOTICE

After a ride, allow the engine to idle for 30 seconds before stopping the engine. This will allow the turbo system to cool down.

1. Place the transmission in PARK.
2. Stop the engine. Turn the key back on to the accessory or ON position without starting the engine. Slowly release the brake pedal and make sure the transmission is in PARK before exiting the vehicle, verifying that the PARK position is shown on the display.
3. Prior to securing the vehicle, the key switch must remain in the ON position, the suspension mode switch must be in the COMFORT setting, and the demo mode timeout must not be active while securing the vehicle. Shock damping settings can be verified on the Suspension visualization screen.
4. Secure the vehicle.

WARNING

Vehicles equipped with DYNAMIX active suspension must be powered on, set to COMFORT mode, and properly functioning in order to ensure the shocks are operating at their minimum compression damping setting prior to securing the vehicle for transport. Failure to ensure the shocks are in their minimum compression damping setting prior to securing the vehicle can potentially lead to a reduction of intended strap tension while trailering.

5. After the vehicle has been secured, verify the gauge indicates PARK, and turn the vehicle power off. Verify also that the suspension compression damping values are still soft after securing the vehicle. If after securing the suspension demo mode has timed out or the suspension has moved to a FIRM setting as indicated on the Suspension control screen, cycle the key switch, place the mode switch in COMFORT mode, and re-tighten the straps per step number 3.
6. Remove the key to prevent loss during transporting. Secure the fuel cap and seats. Ensure that the seats are attached correctly and are not loose.

⚠ WARNING

Cargo and other loose vehicle parts may fly off while transporting this vehicle. Secure or remove all cargo, and inspect the unit for loose parts prior to transport.

7. Always tie the frame of the POLARIS vehicle to the transporting unit securely with suitable straps or rope. Do not attach tie straps to the front control arm bolt pockets.

- ① Front Tie-Down
- ② Front Tie-Downs (both sides)
- ③ Rear Tie-Down

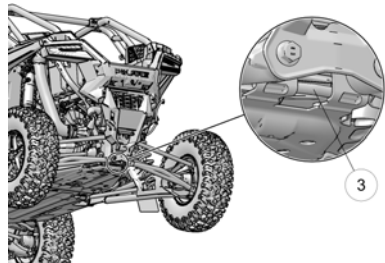
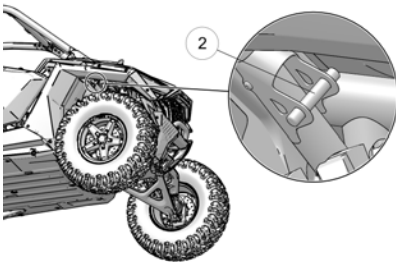
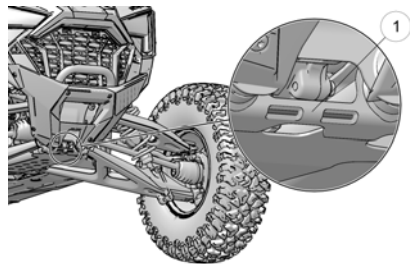

SPECIFICATIONS

RZR TURBO R

Gross Vehicle Weight*	
SPORT: 2780 lbs (1261 kg) California Models: 2785 lbs (1263 kg) PREMIUM: 2820 lbs (1279 kg) California Models: 2825 lbs (1281 kg) PREMIUM without Ride Command Package: 2807 lbs (1273 kg) California Models: 2812 lbs (1276 kg) ULTIMATE: 2850 lbs (1293 kg) California Models: 2855 lbs (1295 kg)	
Dry Weight*	
SPORT: 1943 lbs (881 kg) California Models: 1948 lbs (884 kg) PREMIUM: 1983 lbs (899 kg) California Models: 1988 lbs (902 kg) PREMIUM without Ride Command Package: 1970 lbs (894 kg) California Models: 1975 lbs (896 kg) ULTIMATE: 2013 lbs (913 kg) California Models: 2018 lbs (915 kg)	
<p>*Dry weight is also listed on the Certificate of Origin for your vehicle in the Shipping Weight field. The dry weight is estimated based on the manufactured weight of the vehicle minus any serviceable fluids and may also exclude the weight of factory installed accessories not essential to the vehicle's basic operation as outlined in the ANSI®/ROHVA® 1-2016 standard.</p>	
Test GVW - Rollover Protection System (ROPS)	3100 lbs. (1406 kg) per OSHA SM 29CFR 1928.53
Rear Cargo Box Capacity	300 lbs. (136 kg)
Maximum Weight Capacity (Payload)	730 lbs. (331 kg) (including riders, cargo and accessories)
Fuel Capacity	12.0 gal. (45.4 L)
Engine Oil Capacity	2.75 qts. (2.6 L)
Coolant Capacity	12.3 qts. (11.6 L)
Demand Drive Fluid Capacity	9.5 oz. (280 ml)

SPECIFICATIONS

Transmission Oil Capacity	61 oz. (1800 ml)
Overall Length/Width/Height	128 / 74 / 74.4 in. (325 / 188 / 189 cm)
Wheelbase	96 in. (244 cm)
Ground Clearance	16 in. (41 cm)
Engine	4-Stroke DOHC Twin Cylinder Turbocharged
Displacement	925 cc
Bore x Stroke	93mm x 68mm
Stator Output	900W @ 3000 RPM
Compression Ratio	9.0:1
Starting System	Electric
Fuel System	Electronic fuel injection
Ignition System	ECU
Spark Plug / Gap	NGK® MR9F / 0.7-0.8 mm
Front Suspension *Usable Travel is measured with the vehicle in full droop from the bottom of the tire to the bottom of the skid plate.	Light Weight Boxed Dual A-Arm with 3 Piece Stabilizer Bar and Unitized Hubs 27" (69 cm) Usable Travel* 22.25" (57 cm) Wheel Travel
Rear Suspension *Usable Travel is measured with the vehicle in full droop from the bottom of the tire to the bottom of the skid plate.	Tubular Trailing Arm with boxed gusseting and Toe Link, Standard-Clearance Radius Rods, and Stabilizer Bar and Unitized Hubs 28.3" (72 cm) Usable Travel* 22.4" (57 cm) Wheel Travel
Lubrication System	Wet Sump
Driving System Type	Automatic POLARIS Variable Transmission
Shift Type	Dual Range P/R/N/L/H
Tire Size - Front and Rear	32 x 10-15 Maxxis Rampage Fury 8-Ply Rated Wheel Size 15x7

SPECIFICATIONS

Tire Pressure	Front: 15 psi (103 kPa) Rear: 15 psi (103 kPa)
Brakes, Front/Rear	4-Wheel Hydraulic Disc with Triple-Bore Front and Dual-Bore Rear Calipers Aluminum Top Hat Rotor
Headlights	2 dual beam LED cluster
Taillights	2 LED cluster
Brake Lights	2 LED cluster
Instrument Cluster	LCD
Auxiliary DC Outlet	12V

SPECIFICATIONS

RZR TURBO R 4

Gross Vehicle Weight*	
<p>SPORT: 3445 lbs (1563 kg) California Models: 3450 lbs (1565 kg)</p> <p>PREMIUM: 3539 lbs (1605 kg) California Models: 3544 lbs (1608 kg)</p> <p>PREMIUM without Ride Command Package: 3520 lbs (1597 kg) California Models: 3525 lbs (1599 kg)</p> <p>ULTIMATE: 3562 lbs (1616 kg) California Models: 3567 lbs (1618 kg)</p>	
Dry Weight*	
<p>SPORT: 2169 lbs (984 kg) California Models: 2174 lbs (986 kg)</p> <p>PREMIUM: 2263 lbs (1026 kg) California Models: 2268 lbs (1029 kg)</p> <p>PREMIUM without Ride Command Package: 2244 lbs (1018 kg) California Models: 2249 lbs (1020 kg)</p> <p>ULTIMATE: 2286 lbs (1037 kg) California Models: 2291 lbs (1039 kg)</p>	
<p>*Dry weight is also listed on the Certificate of Origin for your vehicle in the Shipping Weight field. The dry weight is estimated based on the manufactured weight of the vehicle minus any serviceable fluids and may also exclude the weight of factory installed accessories not essential to the vehicle's basic operation as outlined in the ANSI®/ROHVA® 1-2016 standard.</p>	
Test GVW - Rollover Protection System (ROPS)	3850 lbs. (1746 kg) per OSHA SM 29CFR 1928.53
Rear Cargo Box Capacity	300 lbs. (136 kg)
Maximum Weight Capacity (Payload)	1160 lbs. (526 kg) (including riders, cargo and accessories)
Fuel Capacity	13.0 gal. (49.2 L)
Engine Oil Capacity	2.75 qts. (2.6 L)
Coolant Capacity	13.3 qts. (12.6 L)
Demand Drive Fluid Capacity	9.5 oz. (280 ml)
Transmission Oil Capacity	61 oz. (1800 ml)

SPECIFICATIONS

Overall Length/Width/Height	157 / 74 / 77 in. (340 / 188 / 196 cm)
Wheelbase	125 in. (318 cm)
Ground Clearance	16 in. (41 cm)
Engine	4-Stroke DOHC Twin Cylinder Turbocharged
Displacement	925 cc
Bore x Stroke	93mm x 68mm
Stator Output	900W @ 3000 RPM
Compression Ratio	9.0:1
Starting System	Electric
Fuel System	Electronic fuel injection
Ignition System	ECU
Spark Plug / Gap	NGK® MR9F / 0.7-0.8 mm
Front Suspension *Usable Travel is measured with the vehicle in full droop from the bottom of the tire to the bottom of the skid plate.	Light Weight Boxed Dual A-Arm with 3 Piece Stabilizer Bar and Unitized Hubs 27" (69 cm) Usable Travel* 22.25" (57 cm) Wheel Travel
Rear Suspension *Usable Travel is measured with the vehicle in full droop from the bottom of the tire to the bottom of the skid plate.	Tubular Trailing Arm with boxed gusseting and Toe Link, Standard-Clearance Radius Rods, and Stabilizer Bar and Unitized Hubs 28.3" (72 cm) Usable Travel* 22.4" (57 cm) Wheel Travel
Lubrication System	Wet Sump
Driving System Type	Automatic POLARIS Variable Transmission
Shift Type	Dual Range P/R/N/L/H
Tire Size - Front and Rear	32 x 10-15 Maxxis Rampage Fury 8-Ply Rated Wheel Size 15x7
Tire Pressure	Front: 18 psi (124 kPa)

SPECIFICATIONS

	Rear: 18 psi (124 kPa)
Brakes, Front/Rear	4-Wheel Hydraulic Disc with Triple-Bore Front and Dual-Bore Rear Calipers Aluminum Top Hat Rotor
Headlights	2 dual beam LED cluster
Taillights	2 LED cluster
Brake Lights	2 LED cluster
Instrument Cluster	LCD
Auxiliary DC Outlet	12V

POLARIS PRODUCTS

LUBRICANTS / SERVICE PRODUCTS

PART NUMBER	DESCRIPTION
Engine Lubricant	
2870791	Fogging Oil — 12 fl oz (355 mL) Aerosol
2876244	PS-4 Full Synthetic 5W-50 4-Cycle Oil — 1 qt (0.95 L)
2876245	PS-4 Full Synthetic 5W-50 4-Cycle Oil — 1 gal (3.8 L)
2878920	PS-4 Extreme Duty Synthetic 10W-50 4-Cycle Oil — 1 qt (0.95 L)
2878919	PS-4 Extreme Duty Synthetic 10W-50 4-Cycle Oil — 1 gal (3.8 L)
Gearcase / Transmission Lubricants	
2878068	AGL Full Synthetic Gearcase Lubricant & Transmission Fluid — 1 qt (0.95 L)
2878069	AGL Full Synthetic Gearcase Lubricant & Transmission Fluid — 1 gal (3.8 L)
2877922	Demand Drive Fluid — 1 qt (0.95 L)
2877923	Demand Drive Fluid — 1 gal (3.8 L)
2870465	Pump for 1 gal (3.8 L) Jug
Coolant	
2880514	Antifreeze 50/50 Premix — 1 qt (0.95 L)
2880513	Antifreeze 50/50 Premix — 1 gal (3.8 L)
Grease / Specialized Lubricants	
2871312	Grease Gun Kit, All Season Grease
2871322	All Season Grease — 3 fl oz (89 mL) Cartridge
2871423	All Season Grease — 14 fl oz (414 mL) Cartridge
2876160	ATV Angle Drive Fluid — 1 qt (0.95 L)

POLARIS PRODUCTS

PART NUMBER	DESCRIPTION
2872276	ATV Angle Drive Fluid — 2.5 gal (9.5 L)
2871460	Premium Starter Grease
2871515	U-Joint Grease — 3 fl oz (89 mL) Cartridge
2871551	U-Joint Grease — 14 fl oz (414 mL) Cartridge
2871329	Dielectric Grease (Nyogel®)
Additives / Miscellaneous	
2871326	Carbon Clean
2870652	Fuel Stabilizer
2872189	DOT 4 Brake Fluid
2871956	Loctite® 565 Thread Sealant
2830438	POLARIS Battery Trickle Charger

TROUBLESHOOTING

DRIVE BELT WEAR / BURN

POSSIBLE CAUSE	SOLUTION
Driving onto a pickup or tall trailer in high range	Use low range during loading.
Starting out going up a steep incline	Use low range. See warnings in the Safety chapter.
Driving at low RPM or ground speed (3-7 MPH/ 5-11 km/h)	Drive at a higher speed or use low range more frequently. See the Gear Selector section for details.
Insufficient warm-up at low ambient temperatures	Warm the engine at least 5 minutes. With the transmission in neutral, advance the throttle to about 1/8 throttle in short bursts, 5 to 7 times. The belt will become more flexible and prevent belt burning.
Slow/easy clutch engagement	Use the throttle quickly and effectively.
Hauling heavy cargo/pushing at low RPM/low ground speed	Use low range only.
Utility use/plowing	Use low range only.
Stuck in mud or snow	Shift the transmission to low range and carefully use fast, aggressive throttle application to engage clutch. WARNING! Excessive throttle may cause loss of control and vehicle rollover.
Climbing over large objects from a stopped position	Shift the transmission to low range and carefully use fast, brief, aggressive throttle application to engage clutch. WARNING! Excessive throttle may cause loss of control and vehicle rollover.

TROUBLESHOOTING

POSSIBLE CAUSE	SOLUTION
Belt slippage from water or snow ingestion into the PVT system	Dry out the PVT (see the PVT Drying section for details). Prevent water from entering the PVT outlet duct. Inspect clutch seals for damage if repeated leaking occurs.
Clutch malfunction	Your POLARIS dealer can assist.
Poor engine performance	Check for fouled plugs or foreign material in gas tank or fuel lines. Your POLARIS dealer can assist.
Slippage from failure to warm up belt	Always warm up the belt by operating below 30 MPH (48 km/h) for one mile (1.5 km) and for 5 miles (8 km) or more when temperature is below freezing.
Wrong or missing belt	Install the recommended belt.
Improper break-in	Always break in a new belt and/or clutch. See page 84.
Failed belt	Remove the belt and clean away any debris from the clutch box, clutch duct and engine compartment. Install a new belt. WARNING! Failure to remove ALL debris when replacing the belt could result in vehicle damage and severe injury or death. See the Belt Replacement / Debris Removal section for details.

ENGINE DOESN'T TURN OVER

POSSIBLE CAUSE	SOLUTION
Low battery voltage	Recharge the battery to 12.8 VDC
Loose battery connections	Check all connections and tighten
Loose solenoid connections	Check all connections and tighten
Loose electronic control box connections	Inspect, clean, reinstall connectors; blow on EFI fuse to remove impurities
Mechanical failure	Your POLARIS dealer or other qualified person can assist.

ENGINE TURNS OVER, FAILS TO START**WARNING**

Never pour fuel or other flammable liquid into the throttle body air inlet opening in an attempt to start the vehicle. This could result in a flash fire causing serious injury or death.

POSSIBLE CAUSE	SOLUTION
Out of fuel	Refuel
Clogged fuel filter	Your POLARIS dealer or other qualified person can assist.
Water is present in fuel	Drain the fuel system and refuel
Old or non-recommended fuel	Replace with fresh recommended fuel
Fouled or defective spark plugs	Inspect plugs and replace if necessary
No spark to spark plug	Inspect plugs and replace if necessary
Water or fuel in crankcase	Your POLARIS dealer or other qualified person can assist.
Low battery voltage	Recharge the battery to 12.8 VDC
Loose ignition connections	Check all connections and tighten

TROUBLESHOOTING

POSSIBLE CAUSE	SOLUTION
Mechanical failure	Your POLARIS dealer or other qualified person can assist.
Check PDM Fuses	See the PDM Fuse Troubleshooting section for details.

ENGINE BACKFIRES

POSSIBLE CAUSE	SOLUTION
Out of fuel	Refuel
Weak spark from spark plug	Inspect, clean and/or replace spark plugs
Incorrect spark plug gap or heat range	Set gap to specs or replace plugs
Old or non-recommended fuel	Replace with fresh recommended fuel
Incorrectly installed spark plug wires	Your POLARIS dealer or other qualified person can assist.
Incorrect ignition timing	Your POLARIS dealer or other qualified person can assist.
Loose ignition connections	Check all connections and tighten
Water present in fuel	Replace with fresh recommended fuel
Exhaust leak	Check all connections
Mechanical failure	Your POLARIS dealer or other qualified person can assist.

ENGINE PINGS OR KNOCKS

POSSIBLE CAUSE	SOLUTION
Poor quality or low octane fuel	Replace with recommended fuel
Incorrect ignition timing	Your POLARIS dealer or other qualified person can assist.
Incorrect spark plug gap or heat range	Set gap to specs or replace plugs

ENGINE RUNS IRREGULARLY, STALLS OR MISFIRES

POSSIBLE CAUSE	SOLUTION
Loose, missing or kinked boost reference lines	Replace boost reference lines
Loose or missing intake system sensor connections	Inspect connections, tighten or replace as needed
Fouled or defective spark plugs	Inspect, clean and/or replace spark plugs
Worn or defective spark plug wires	Your POLARIS dealer can assist.
Incorrect spark plug gap or heat range	Set gap to specs or replace plugs
Loose ignition connections	Check all connections and tighten
Water present in fuel	Replace with new fuel
Low battery voltage	Recharge battery to 12.8 VDC
Kinked or plugged fuel tank vent line or filter	Inspect and replace
Incorrect fuel	Replace with recommended fuel
Clogged air filter	Inspect and replace clogged/wet air filter, and also check for obstructed intake system, debris or cargo blocking intake vents
Clogged intake pre-filter	Inspect and clean (with soapy water) or replace

TROUBLESHOOTING

POSSIBLE CAUSE	SOLUTION
Other mechanical failure	Your POLARIS dealer can assist.
Possible Lean Fuel Cause	Solution
Low or contaminated fuel	Add or change fuel, clean the fuel system
High ethanol fuel	Replace with recommended fuel
Clogged fuel filter	Your POLARIS dealer can assist.
Low fuel pressure	Your POLARIS dealer can assist.
Loose, missing, torn or kinked boost reference line from manifold to fuel pressure regulator or blow-off valve	Replace boost reference line

ENGINE STOPS OR LOSES POWER

POSSIBLE CAUSE	SOLUTION
Out of fuel	Refuel
Kinked or plugged fuel tank vent line or filter	Inspect and replace
Water is present in fuel	Replace with new fuel
Fouled or defective spark plugs	Inspect, clean and/or replace spark plug
Worn or defective spark plug wires	Your POLARIS dealer can assist.
Incorrect spark plug gap or heat range	Set gap to specs or replace plug
Loose ignition connections	Check all connections and tighten
Low battery voltage	Recharge the battery to 12.8 VDC
Incorrect fuel	Replace with fresh recommended fuel
Clogged air filter	Inspect and replace clogged/wet air filter, and also check for obstructed intake system, debris or cargo blocking intake vents

POSSIBLE CAUSE	SOLUTION
Clogged intake pre-filter	Inspect and clean (with soapy water) or replace
Other mechanical failure	Your POLARIS dealer can assist.
Overheated engine	Clean radiator screen and core, clean engine exterior, check coolant level. Your POLARIS dealer can assist.
Loose intake system connections	Inspect connections, tighten or replace as needed
Overheated intake air system	Inspect water lines for leaks or kinks, repair or replace as needed

DIAGNOSTIC DISPLAY CODE DEFINITIONS

Open Load: There is a break in the wires that lead to the item listed in the chart (injector, fuel pump, etc.), or the item has failed.

Short-to-Ground: The wire is shorted to ground between the electronic control unit and the item listed in the chart.

Shorted Load: The wires leading to the item listed in the chart are shorted together, or the item has shorted internally.

Short-to-Battery: The wire leading from the item listed in the chart to the electronic control unit is shorted to a wire at battery voltage.

DIAGNOSTIC CODES		
CONDITION	SPN	FMI
Engine Control Module		
Manifold Absolute Pressure/Barometric Pressure Sensor Circuit Low	102	4
Accelerator Position 2 Voltage Too Low	29	4
System Voltage Low	168	4
Gear Shift Position Circuit "A" Low	523	4
Engine Coolant Temperature Sensor 1 Circuit High	110	3
Engine Temperature Sensor Engine Overheat Shutdown	110	0

TROUBLESHOOTING

DIAGNOSTIC CODES		
CONDITION	SPN	FMI
Engine Coolant Temperature Sensor 1 Circuit Low	110	4
Crankshaft Position Sensor "A" Circuit	636	8
Accelerator Position 2 Voltage Too High	29	3
Barometric Pressure Sensor "A" Circuit Low	108	4
Engine Coolant Over Temperature Condition	110	16
Camshaft Position Sensor "A" Circuit Bank 1 or Single Sensor	637	8
Engine Coolant Temperature Sensor 1 Circuit Intermittent/Erratic	110	10
Manifold Absolute Pressure/Barometric Pressure Sensor Circuit High	102	3
System Voltage High	168	3
Intake Air Temperature Sensor 1 Circuit Intermittent Bank 1	105	10
Fuel Level Sensor "A" Circuit Low	96	4
Throttle/Pedal Position Sensor/Switch "A" Circuit High	51	3
Throttle/Pedal Position Sensor/Switch "C" Circuit Low	91	4
Fuel Level Sensor "A" Circuit High	96	3
Barometric Pressure Sensor "A" Circuit High	108	3
Vehicle Speed Sensor "A" Circuit Intermittent/Erratic/High	84	2
Intake Air Temperature Sensor 1 Circuit High Bank 1	105	3
Crankshaft Position Sensor "A" Circuit Intermittent	636	2
Engine Speed Error in Engine Speed Computation	190	31
Intake Air Temperature Sensor 1 Circuit Low Bank 1	105	4
Throttle/Pedal Position Sensor/Switch "C" Circuit High	91	3

TROUBLESHOOTING

DIAGNOSTIC CODES		
CONDITION	SPN	FMI
Throttle/Pedal Position Sensor/Switch "A" Circuit Low	51	4
Fan Relay Driver Circuit Driver Circuit Short to B+	1071	3
Ignition Coil "A" Primary Control Circuit High	1268	3
Fuel Pump Primary Circuit	1347	5
HO2S Heater Control Circuit High Bank 1 Sensor 1	520209	3
Cylinder 1 Injector "A" Circuit High	651	3
Low Speed CAN Communication Bus	516125	2
Injector 3 Driver Circuit Grounded	653	4
Knock/Combustion Vibration Sensor "A" Circuit Range/Performance	731	2
Starter Relay "A" Circuit Low	677	4
Ignition Coil "B" Primary Control Circuit High	1269	3
Cylinder 2 Injector "A" Circuit High	652	3
ECU Output Supply Voltage 2 Voltage Above Warning Level	3598	16
Cylinder 3 Injector "A" Circuit High	653	3
Ignition Coil "B" Primary Control Circuit Low	1269	4
Cylinder 4 Injector "A" Circuit High	654	3
Fuel Pump Secondary Circuit Low	1347	4
Fuel Pump Secondary Circuit High	1347	3
Cylinder 1 Injector "A" Circuit Low	651	4
Cylinder 2 Injector "A" Circuit	652	5
Cylinder 4 Injector "B" Circuit Low	654	4
O2 Sensor Circuit Low Voltage Bank 1 Sensor 1	3056	4

TROUBLESHOOTING

DIAGNOSTIC CODES		
CONDITION	SPN	FMI
HO2S Heater Control Circuit Low Bank 1 Sensor 1	520209	4
EVAP System Purge Control Valve "A" Circuit	520202	3
Chassis Relay Driver Circuit Grounded	520208	4
All Wheel Drive Control Circuit Driver Circuit Grounded	520207	4
Chassis Relay Driver Circuit Open/Grounded	520208	5
HO2S Heater Control Circuit Bank 1 Sensor 1	520209	5
Ignition Coil Primary Driver 3 Driver Circuit Grounded	1270	4
Throttle/Pedal Position Sensor/Switch "B" Circuit High	520198	3
Misfire Detected - Fueling Disabled	65590	31
ECU Output Supply Voltage 2 Voltage Below Warning Level	3598	18
EVAP System Purge Control Valve "A" Circuit Open	520202	5
Cylinder 1 Misfire Detected	65591	7
Cylinder 3 Misfire Detected	65593	7
O2 Sensor Circuit Bank 1 Sensor 1	3056	5
Random/Multiple Cylinder Misfire Detected	65599	7
Cylinder 2 Injector "A" Circuit Low	652	4
Single Cylinder Misfire (Cylinder not Specified)	65590	7
Cylinder 4 Injector "A" Circuit Low	654	5
Fan Relay Driver Circuit Driver Circuit Grounded	1071	4
Ignition Coil "A" Primary Control Circuit Low	1268	4
Powertrain Relay Stuck	66013	7
Fan Relay Driver Circuit Driver Circuit Open/Grounded	1071	5
Cylinder 1 Injector "A" Circuit	651	5

TROUBLESHOOTING

DIAGNOSTIC CODES		
CONDITION	SPN	FMI
Ignition Coil Primary Driver 3 Driver Circuit Short to B+	1270	3
Cylinder 4 Misfire Detected	65594	7
O2 Sensor Circuit High Voltage Bank 1 Sensor 1	3056	3
ECU Output Supply Voltage 1 Voltage Above Warning Level	3597	16
All Wheel Drive Control Circuit Driver Circuit Short to B+	520207	3
Accelerator Sensor Synchronicity Fault - Sensor Difference Exceeds Limit Condition Exists	520308	31
Throttle Body Control - Limp Home Position Check Failed Condition Exists	520280	31
Throttle Position Sensor Neither Position Sensor Passed Test	520276	12
Function Monitoring MoFTrq Comparison Error	520385	31
Throttle Body Control - Mechanical Stop Adptation Failure Condition Exists	520281	31
RBA Monitoring Error Memory Read/Write	520383	31
ECU ADC Fault - No Load Condition Exists	520306	31
EVAP System Purge Control Valve "A" Circuit Shorted	520202	4
Chassis Relay Driver Circuit Short to B+	520208	3
ETC Accelerator Position Sensor Outputs 1 & 2 Correlation. Correlation Fault	65613	2
Cylinder 3 Injector "A" Circuit Low	653	5
All Wheel Drive Control Circuit Driver Circuit Open/Grounded	520207	5
ECU Output Supply Voltage 1 Voltage Below Warning Level	3597	18
Cylinder 2 Misfire Detected	65592	7
Ignition Coil Primary Driver 4 Driver Circuit Short to B+	1271	3

TROUBLESHOOTING

DIAGNOSTIC CODES		
CONDITION	SPN	FMI
Throttle/Pedal Position Sensor/Switch "B" Circuit Low	520198	4
EMM Alarm FCCU Hardware Module	520248	31
RBA Monitoring Error T15	520384	31
Monitoring Error Starter Release	520390	31
ECU ADC Fault - Voltage Condition Exists	520307	31
ICO Request MoCSOP Module	520386	31
ECU Monitoring of Injection Cut Off (Level 2) Condition Exists	520289	31
Throttle Body Control - Power Stage Not Plausible	520277	2
Knock Sensor Positive Line Voltage Too High	520331	3
Knock Sensor Positive Line Voltage Too Low	520331	4
Brake Switch (1 or 2 Indeterminable) Brake Switch Correlation Fault	520285	2
Intake Air System Leak Bank 1	520338	31
Drive Mode Select Switch Signal Fault	524067	2
Knock Sensor Negative Line Voltage Too High	520332	3
Throttle Body Control - Power Stage Minimum	520277	4
Monitoring Error Post Build	520387	31
ECU Monitoring Error (Level 3) Condition Exists	520287	31
Throttle Body Control - Power Stage Signal Error	520277	8
High Speed CAN Communication Bus	521092	2
Drive Mode Select Switch Voltage Too High	524067	3
Accelerator Position/Brake Position Interaction Condition Exists	520275	31
System Too Lean Off Idle Bank 1	520344	17

TROUBLESHOOTING

DIAGNOSTIC CODES		
CONDITION	SPN	FMI
Throttle Body Control - Power Stage Maximum	520277	3
Throttle Body Control - Position Deviation Fault Condition Exists	520284	31
ECU Monitoring of Injection Cut Off (Level 1) Condition Exists	520288	31
Knock Sensor Negative Line Voltage Too Low	520332	4
Throttle Body Control - Adaption Aborted Condition Exists	520279	31
System Too Rich Off Idle Bank 1	520344	15
Throttle Body Control Maximum	520283	3
Drive Mode Select Switch Voltage Too Low	524067	4
Monitoring Error ECU Ignition Check	520388	31
Throttle Body Control - Return Spring Check Failed Condition Exists	520278	31
Function Monitoring MoFAir Group	520249	31
RBA Monitoring Error Keep Alive	520382	31
Throttle Position Sensor Position Sensor Correlation Fault	520276	2
Torque Request CAN Message	65557	22
Front Wheel Back Drive (Active Descent System) Driver Circuit Open/Grounded	520203	5
Front Wheel Back Drive (Active Descent System) Driver Circuit Short to B+	520203	3
Gear Sensor Signal Abnormal Update Rate	523	9
Lost Communication With Front Controls/Display Interface Module	524067	9
Brake Lamp Open Circuit	520320	5
Brake Lamp Shorted to Ground	520320	4

TROUBLESHOOTING

DIAGNOSTIC CODES		
CONDITION	SPN	FMI
Front Wheel Back Drive (Active Descent System) Driver Circuit Grounded	520203	4
ESC 65312 checksum failure	65557	23
Brake Lamp Shorted to Battery	520320	3
System Too Lean Bank 2	520205	17
Coolant Thermostat (Coolant Temperature Below Thermostat Regulating Temperature)	110	17
Engine Coolant Temperature Sensor 1 Circuit Intermittent/Erratic	110	10
Rear Differential Output Driver Circuit Open/Grounded	746	5
System Too Lean Bank 1	520204	17
Rear Differential Output Driver Circuit Grounded	746	4
Knock/Combustion Vibration Sensor "A" Circuit Range/Performance	731	2
Rear Differential Output Driver Circuit Short to B+	746	3
System Power Voltage Below Critical Level	168	1
Engine Temperature Sensor Temperature above normal range	110	15
System Too Rich Bank 2	520205	15
System Too Rich Bank 1	520204	15
Manifold Absolute Pressure/Barometric Pressure Sensor Circuit Range/Performance	102	2
Manifold absolute pressure sensor out of range low	102	17
Manifold absolute pressure sensor out of range high	102	15
Charge Air Cooler Cooling Fan Control Circuit Low	524280	4
Charge Air Cooler Cooling Fan Control Circuit High	524280	3

TROUBLESHOOTING

DIAGNOSTIC CODES		
CONDITION	SPN	FMI
Gear Shift Position Circuit "A" High	523	3
O2 Sensor Signal Biased/Stuck Lean Bank 2 Sensor 1	3057	17
Ambient Air Temperature Sensor Circuit "A" High	171	3
AC Condenser Fan Relay Open	520624	5
Fuel Level Sensor "A" Circuit Range/Performance	96	2
O2 Sensor Circuit High Voltage Bank 2 Sensor 1	3057	3
AC Condenser Fan Relay Low	520624	4
Fuel Level Signal Below Normal Operating Range	96	18
O2 Sensor Signal Circuit Shorted to Heater Circuit Bank 1 Sensor 1	3056	2
O2 Sensor Signal Biased/Stuck Lean Bank 1 Sensor 1	3056	17
O2 Sensor Heater Circuit Bank 1 Sensor 1	520209	2
Ambient Air Temperature Sensor Circuit "A" Range/Performance	171	2
Crankshaft Position Sensor "A" Circuit Intermittent	636	2
O2 Sensor Circuit Low Voltage Bank 2 Sensor 1	3057	4
O2 Sensor Circuit Slow Response Bank 1 Sensor 1	3056	12
Fuel Level Signal Above Normal Operating Range	96	16
System Too Lean Off Idle Bank 2	520345	17
Gear Shift Position Circuit "A" Range/Performance	523	11
System Too Rich Off Idle Bank 2	520345	15
O2 Sensor Signal Biased/Stuck Rich Bank 2 Sensor 1	3057	15
O2 Sensor Signal Biased/Stuck Rich Bank 1 Sensor 1	3056	15
AC Condenser Fan Relay High	520624	3

TROUBLESHOOTING

DIAGNOSTIC CODES		
CONDITION	SPN	FMI
Charge Air Cooler Cooling Fan Control Circuit/Open	524280	5
Ambient Air Temperature Sensor Circuit "A" Low	171	4
O2 Sensor Signal Circuit Shorted to Heater Circuit Bank 2 Sensor 1	3057	2
O2 Sensor Circuit Slow Response Bank 2 Sensor 1	3057	12
Charge Air Cooler Cooling Fan 2 Control Circuit Low	524281	4
Charge Air Cooler Cooling Fan 2 Control Circuit High	524281	3
Ignition Coil "A" Primary Control Circuit High	1268	3
Ignition Coil Primary Driver 3 Driver Circuit Grounded	1270	4
Ignition Coil "A" Primary Control Circuit Low	1268	4
O2 Sensor Heater Circuit Bank 2 Sensor 1	520210	2
Charge Air Cooler Cooling Fan 2 Control Circuit/Open	524281	5
Ignition Coil "B" Primary Control Circuit Low	1269	4
O2 Sensor Circuit Bank 2 Sensor 1	3057	5
Intake Air Temperature Too High	105	15
Ignition Coil "B" Primary Control Circuit High	1269	3
HO2S Heater Control Circuit High Bank 2 Sensor 1	520210	3
HO2S Heater Control Circuit Bank 2 Sensor 1	520210	5
HO2S Heater Control Circuit Low Bank 2 Sensor 1	520210	4
Ignition Coil Primary Driver 3 Driver Circuit Short to B+	1270	3
Ignition Coil Primary Driver 4 Driver Circuit Short to B+	1271	3
Knock Sensor 2 Negative Line Short To GND	520126	4
Fan 2 Control Circuit Low	1557	4
Fan 2 Control Circuit High	1557	3

TROUBLESHOOTING

DIAGNOSTIC CODES		
CONDITION	SPN	FMI
Knock Sensor 2 Negative Line Short To BAT	520126	3
Fan 2 Control Circuit	1557	5
Knock Sensor 2 Positive Line Short To BAT	520127	3
Transmission Mode Switch "A" Circuit	520467	31
Knock Sensor 2 Positive Line Short To GND	520127	4
System Too Rich at Idle Bank 1	520342	15
ECU Output Supply Voltage 2 Voltage Above Critical Level	3598	0
Starter Relay "A" Circuit	677	5
Throttle Body Control - Return Spring Check Failed Condition Exists	520278	31
System Too Lean at Idle Bank 2	520343	17
Transmission Mode Switch "B" Circuit	520468	31
ECU Output Supply Voltage 1 Voltage Too Low	3597	4
System Too Rich at Idle Bank 2	520343	15
Turbocharger/Supercharger Boost Sensor "A" Circuit Low	1127	4
Trunk brake lamp short to GND	520172	4
Gear Shift Position Circuit "A"	523	2
ECU Output Supply Voltage 2 Voltage Too Low	3598	4
ECU Memory EEPROM Read/Write Failure	628	12
Trunk brake lamp short to BAT	520172	3
Turbocharger/Supercharger Boost Sensor "A" Circuit High	1127	3
Reverse Override Switch Stuck	524145	31
System Too Lean at Idle Bank 1	520342	17

TROUBLESHOOTING

DIAGNOSTIC CODES		
CONDITION	SPN	FMI
ECU Output Supply Voltage 1 Voltage Above Critical Level	3597	0
Throttle Body Control - Repeated Adaptation Failed Condition Exists	520282	31
Starter Relay "A" Circuit High	677	3
EPS Module		
Software initialization error	520229	31
ECU Memory EEPROM Read/Write Failure	628	12
Steering motor current uncontrolled	520222	6
Excessive EPS internal temperature	520225	0
System Power Voltage Too High	168	3
Steering angle sensor out of range	1807	31
EPS internal temperature warning	520225	16
External fault, engine speed reception	524000	19
Steering angle sensor not calibrated	1807	13
System Power Voltage Too Low	168	4
EPAS Power Save Condition Power Save Timeout	520231	31
Motor driver IC error	520448	12
External fault, vehicle speed reception	84	19
Steering Over Current Shut Down Current Above Normal or Grounded	520221	6
Position Encoder Error Position Encoder Error	520228	11
Internal fault, thermistor malfunction	520225	12
Motor relay error	520552	12
CPU error	65580	12

TROUBLESHOOTING

DIAGNOSTIC CODES		
CONDITION	SPN	FMI
Steering angle sensor out of range	1807	12
EPS motor drive voltage out of range	520672	31
Power relay error	520672	12
Power supply IC error	524086	12
Steering Torque Full Failure	520224	12
EPAS CAN Communications Transmit Error No TX Message for x Seconds	520227	2
EPS Calibration CRC error	630	23
Steering Torque Partial Failure	520223	12
Lost Communication With ECM/PCM "A"	520226	2
Suspension Control Module		
Suspension Control Module Acceleration Sensor Measurement Out of Range	516115	12
Engine Speed Data Invalid	524000	2
Absolute Shock Current Error - Rebound Rear Right	516314	11
Steering Angle and Velocity Signal Not Received from Power Steering Module	516117	9
Shock Valve Supply Relay Driver Shorted to Low Source or Open Circuit	516110	4
Suspension Mode Switch Input Voltage in Invalid Range	516098	2
Gear Position Signal Not Received from Engine Control Module	516121	9
Valve Driver Shorted Low or Open Circuit - Compression Front Left	516106	4
System Voltage below minimum - most severe level	516126	1
Absolute Shock Current Error - Compression Rear Right	516114	11

TROUBLESHOOTING

DIAGNOSTIC CODES		
CONDITION	SPN	FMI
Valve Driver Shorted High - Compression Front Right	516107	3
Suspension Control Module CAN Communication Transmit Error	516125	11
Absolute Shock Current Error - Rebound Rear Left	516313	11
Absolute Shock Current Error - Compression Front Right	516112	11
Suspension Control Module Temperature Below Normal	516115	17
Suspension Mode Switch Input - Voltage below minimum threshold	516098	4
Requested Power Steering Mode does not Match Active Power Steering Mode	524116	31
Valve Driver Shorted Low or Open Circuit - Compression Front Right	516107	4
Valve Driver Shorted Low or Open Circuit - Rebound Front Right	523991	4
Absolute Shock Current Error - Compression Rear Left	516113	11
Suspension Control Module Temperature Above Normal	516115	15
Vehicle Speed Data Implausible Based On Slew Rate	516123	21
Vehicle Speed Signal Not Received from Engine Control Module	516120	9
Valve Driver Shorted High - Compression Rear Left	516108	3
Operator Button 51 [Mode Up] - Data Erratic, Intermittent Or Incorrect	523963	2
Valve Driver Shorted Low or Open Circuit - Compression Rear Left	516108	4
Brake Switch Status Data Invalid	520572	2
Vehicle Speed Data - Implausible - Based on Engine Speed and Gear	516123	20

TROUBLESHOOTING

DIAGNOSTIC CODES		
CONDITION	SPN	FMI
Steering Alignment Out of Range - Above Normal	516122	15
Suspension Control Module Mounting Orientation Error Detected	516115	2
System Voltage above maximum - most severe level	516126	0
Valve Driver Shorted Low or Open Circuit - Compression Rear Right	516109	4
Valve Driver Shorted High - Compression Rear Right	516109	3
Valve Driver Shorted High - Compression Front Left	516106	3
Mode Up/Down and Pucker Button Signal Not Received from Steering Wheel	516183	9
Operator Button 50 [Pucker] - Data Erratic, Intermittent Or Incorrect	523962	2
Valve Driver Shorted Low or Open Circuit - Rebound Rear Right	523993	4
System Voltage below minimum moderately severe level	516126	18
Valve Driver Shorted High - Rebound Front Right	523991	3
Valve Driver Shorted High - Rebound Rear Right	523993	3
Engine Speed Signal Not Received from Engine Control Module	516116	9
Valve Driver Shorted High - Rebound Rear Left	523992	3
Operator Button 52 [Mode Down] - Data Erratic, Intermittent Or Incorrect	523964	2
System Voltage above maximum - moderately severe level	516126	16
Absolute Shock Current Error - Rebound Front Left	516311	11
Absolute Shock Current Error - Rebound Front Right	516312	11
Engine Torque Demanded Signal Not Received from Engine Control Module	521038	9

TROUBLESHOOTING

DIAGNOSTIC CODES		
CONDITION	SPN	FMI
Steering Angle Data Invalid	524114	2
Vehicle Speed Data Invalid	516123	2
Transmission Requested Range Data Invalid	162	2
System Voltage Shorted to High Source	516126	3
System Voltage Shorted to Low Source or Open Circuit	516126	4
Shock Valve Supply Relay Driver Shorted High	516110	3
Valve Driver Shorted Low or Open Circuit - Rebound Front Left	523990	4
Steering Alignment Out of Range - Below Normal	516122	17
SW Version / HW Version Compatibility - Data Inconsistent	516119	2
Suspension Mode Switch Input - Voltage Above Maximum Threshold	516098	3
Absolute Shock Current Error - Compression Front Left	516111	11
Accelerator Pedal Position Data Invalid	520574	2
Valve Driver Shorted High - Rebound Front Left	523990	3
Suspension Control Module Internal Error	516124	12
Valve Driver Shorted Low or Open Circuit - Rebound Rear Left	523992	4
Accelerator Pedal Position and Brake Switch Signal Not Received from Engine Control Module	516118	9
Steering Wheel Controls		
Left Hand Control Watchdog Reset Root Cause Not Known	520191	11
Right Hand Control Watchdog Reset Root Cause Not Known	520191	11
Instrument Cluster		

TROUBLESHOOTING

DIAGNOSTIC CODES		
CONDITION	SPN	FMI
Lost Communication With Power Steering Control Module "A"	520230	31
Ride Command Display		
Battery Potential / Power Input 1	168	1

WARRANTY

LIMITED WARRANTY

POLARIS Industries Inc., 2100 Highway 55, Medina, MN 55340 (POLARIS) gives a SIX MONTH LIMITED WARRANTY on all components of your POLARIS vehicle against defects in material or workmanship. Laws and regulations in your jurisdiction may give extra protection. POLARIS further warrants that the spark arrester in this product will meet the efficiency requirements of USFS standard 5100-1C for at least 1000 hours when subjected to normal use and when maintenance and installation are in accordance with POLARIS recommendations.

This warranty covers parts and labor charges for repair or replacement of defective parts and begins on the date of purchase by the original retail purchaser. This warranty is transferable to another owner during the warranty period through a POLARIS dealer, but any such transfer will not extend the original term of the warranty. The duration of this warranty may vary by international region based upon local laws and regulations.

REGISTRATION

At the time of sale, the Warranty Registration Form must be completed by your dealer and submitted to POLARIS within ten days of purchase. Upon receipt of this registration, POLARIS will record the registration for warranty. No verification of registration will be sent to the purchaser as the copy of the Warranty Registration Form will be your proof of warranty coverage. If you have not signed the original registration and received the customer copy, please contact your dealer immediately. **NO WARRANTY COVERAGE WILL BE ALLOWED UNLESS YOUR VEHICLE IS REGISTERED WITH POLARIS.** Initial dealer preparation and set-up of your vehicle is very important in ensuring trouble-free operation. Purchasing a machine in the crate or without proper dealer set-up will void your warranty coverage.

WARRANTY COVERAGE AND EXCLUSIONS

LIMITATIONS OF WARRANTIES AND REMEDIES

This POLARIS limited warranty excludes any failures that are not caused by a defect in material or workmanship. THIS WARRANTY DOES NOT COVER CLAIMS OF DEFECTIVE DESIGN. This warranty also does not cover acts of God, accidental damage, normal wear and tear, abuse or improper handling. This warranty also does not cover any vehicle, component, or part that has been altered structurally, modified, neglected, improperly maintained or used for racing, competition or purposes other than for which it was designed.

This warranty excludes damages or failures resulting from improper lubrication; improper engine timing; improper fuel; surface imperfections caused by external stress, heat, cold or contamination; operator error or abuse; improper component alignment, tension, adjustment or altitude compensation; snow, water, dirt or other foreign substance ingestion/contamination; improper maintenance; modified components; use of aftermarket or unapproved components, accessories, or attachments; unauthorized repairs; or repairs made after the warranty period expires or by an unauthorized repair center.

This warranty excludes damages or failures caused by abuse, accident, fire, or any other cause other than a defect in materials or workmanship and provides no coverage for consumable components, general wear items, or any parts exposed to friction surfaces, stresses, environmental conditions and/or contamination for which they were not designed or not intended, including but not limited to the following items:

- Wheels and tires
- Suspension components
- Brake components
- Seat components
- Clutches and components
- Steering components
- Batteries
- Light bulbs/Sealed beam lamps
- Filters
- Lubricants
- Bushings
- Finished and unfinished surfaces
- Carburetor/Throttle body components
- Engine components
- Drive belts
- Hydraulic components and fluids
- Circuit breakers/Fuses
- Electronic components
- Spark plugs
- Sealants
- Coolants
- Bearings

LUBRICANTS AND FLUIDS

1. Mixing oil brands or using non-recommended oil may cause engine damage. We recommend the use of POLARIS engine oil.
2. Damage or failure resulting from the use of non-recommended lubricants or fluids is not covered by this warranty.

This warranty provides no coverage for personal loss or expense, including mileage, transportation costs, hotels, meals, shipping or handling fees, product pick-up or delivery, replacement rentals, loss of product use, loss of profits, or loss of vacation or personal time.

THE EXCLUSIVE REMEDY FOR BREACH OF THIS WARRANTY SHALL BE, AT POLARIS' OPTION, REPAIR OR REPLACEMENT OF ANY DEFECTIVE MATERIALS, COMPONENTS, OR PRODUCTS. THE REMEDIES SET FORTH IN THIS WARRANTY ARE THE ONLY REMEDIES AVAILABLE TO ANY PERSON FOR BREACH OF THIS WARRANTY. POLARIS SHALL HAVE NO LIABILITY TO ANY PERSON FOR INCIDENTAL, CONSEQUENTIAL OR SPECIAL DAMAGES OF ANY DESCRIPTION, WHETHER ARISING OUT OF EXPRESS OR IMPLIED WARRANTY OR ANY OTHER CONTRACT, NEGLIGENCE, OR OTHER TORT OR OTHERWISE. THIS EXCLUSION OF CONSEQUENTIAL, INCIDENTAL, AND SPECIAL DAMAGES IS INDEPENDENT FROM AND SHALL SURVIVE ANY FINDING THAT THE EXCLUSIVE REMEDY FAILED OF ITS ESSENTIAL PURPOSE.

THE IMPLIED WARRANTY OF FITNESS FOR A PARTICULAR PURPOSE IS EXCLUDED FROM THIS LIMITED WARRANTY. ALL OTHER IMPLIED WARRANTIES (INCLUDING BUT NOT LIMITED TO THE IMPLIED WARRANTY OF MERCHANTABILITY) ARE LIMITED IN DURATION TO THE ABOVE SIX MONTH WARRANTY PERIOD. POLARIS DISCLAIMS ALL EXPRESS WARRANTIES NOT STATED IN THIS WARRANTY. SOME STATES DO NOT PERMIT THE EXCLUSION OR LIMITATION OF INCIDENTAL OR CONSEQUENTIAL DAMAGES OR ALLOW LIMITATIONS ON THE DURATION OF IMPLIED WARRANTIES, SO THE ABOVE LIMITATIONS MAY NOT APPLY TO YOU IF INCONSISTENT WITH CONTROLLING STATE LAW.

WARRANTY

HOW TO OBTAIN WARRANTY SERVICE

If your vehicle requires warranty service, you must take it to a POLARIS Servicing Dealer. When requesting warranty service you must present your copy of the Warranty Registration Form to the dealer. (THE COST OF TRANSPORTATION TO AND FROM THE DEALER IS YOUR RESPONSIBILITY.) POLARIS suggests that you use your original selling dealer; however, you may use any POLARIS Servicing Dealer to perform warranty service.

In the Country where your product was purchased:

Warranty or Service Bulletin repairs must be done by an authorized POLARIS dealer. If you move or are traveling within the country where your product was purchased, Warranty and Service Bulletin repairs may be requested from any authorized POLARIS dealer that sells the same line as your product.

Outside the Country where your product was purchased:

If you are traveling temporarily outside the country where your product was purchased, you should take your product to an authorized POLARIS dealer. You must show the dealer photo identification from the country of the selling dealer's authorized location as proof of residence. Upon residence verification, the servicing dealer will be authorized to perform the warranty repair.

If you move:

If you move to another country, be sure to contact POLARIS Customer Assistance and the customs department of the destination country before you move. Product importation rules vary considerably from country to country. You may be required to present documentation of your move to POLARIS in order to continue your warranty coverage. You may also be required to obtain documentation from POLARIS in order to register your product in your new country. You should warranty register your product at a local POLARIS dealer in your new country immediately after you move to continue your warranty coverage and to ensure that you receive information and notices regarding your vehicle.

If you purchase from a private party:

If you purchase a POLARIS product from a private party, to be kept and used outside of the country in which the product was originally purchased, all warranty coverage will be denied. You must nonetheless register your product under your name and address with a local POLARIS dealer in your country to ensure that you receive safety information and notices regarding your product.

NOTICE

If your product is registered outside of the country where it was purchased and you have not followed the procedure set above, your product will no longer be eligible for warranty or service bulletin coverage of any kind, other than safety recalls. Products registered to government officials or military personnel on assignment outside of the country where the product was purchased will continue to be covered by the Limited Warranty.

Please work with your dealer to resolve any warranty issues. Dealership contacts can be found via this website, if needed:

www.polaris.com/en-us/contact

Should your dealer require any additional assistance, they will contact the appropriate person at POLARIS.

This warranty gives you specific legal rights, and you may also have other rights which vary from state to state or in different countries. If any of the above terms are void because of federal, state, local law, all other warranty terms will remain in effect.

For questions call POLARIS Owner Connections:

United States & Canada: 1-800-POLARIS (1-800-765-2747)

French: 1-800-268-6334

To report a safety defect to Transport Canada, you may either fill out an online defect complaint form at their website:

English: <http://www.tc.gc.ca/recalls>

French: <http://www.tc.gc.ca/rappels>

Or contact their Defect Investigations and Recalls Division by calling toll-free 1-800-333-0510 (Canada) or 819-994-3328 (Ottawa-Gatineau area / International).

WARRANTY

U.S.A. EPA EMISSIONS LIMITED WARRANTY

This emissions limited warranty is in addition to the POLARIS standard limited warranty for your vehicle. POLARIS Industries Inc. warrants that at the time it is first purchased, this emissions-certified vehicle is designed, built and equipped so it conforms with applicable U.S. Environmental Protection Agency emission regulations. POLARIS warrants that the vehicle is free from defects in materials and workmanship that would cause it to fail to meet these regulations.

The warranty period for off road vehicles 100cc or greater emissions-certified vehicles starts on the date of purchase by original retail purchaser and continues for a period of 500 hours of engine operation, 3100 miles (5000 km) of vehicle travel, or 30 calendar months from the date of purchase, whichever comes first. The warranty period for ATVs less than 100cc emissions-certified vehicles starts on the date of purchase by original retail purchaser and continues for a period of 250 hours of engine operation, 1550 miles (2500 km) of vehicle travel, or 30 calendar months from the date of purchase, whichever comes first. This EPA emissions warranty period is extended for at least as long as the standard factory warranty that Polaris provides on the vehicle as a whole. The EPA emissions warranty period does not further extend if you purchase additional warranty coverage in the form of a service contract or other paid warranty extension, but emission-related parts may be covered subject to the terms of any such paid service contract or paid warranty extension.

This emissions limited warranty covers components whose failure increases the vehicle's regulated emissions, and it covers components of systems whose only purpose is to control emissions. Repairing or replacing other components not covered by this warranty is the responsibility of the vehicle owner. This emissions limited warranty does not cover components whose failure does not increase the vehicle's regulated emissions.

For exhaust emissions, emission-related components include any engine parts related to the following systems:

- Air-induction system
- Fuel System
- Ignition system
- Exhaust gas recirculation systems

The following parts are also considered emission-related components for exhaust emissions:

- After treatment devices
- Crankcase ventilation valves
- Sensors
- Electronic control units

The following parts are considered emission-related components for evaporative emissions:

- Fuel Tank
- Fuel Cap
- Fuel Line
- Fuel Line Fittings
- Clamps*
- Pressure Relief Valves*
- Control Valves*
- Control Solenoids*
- Electronic Controls
- Vacuum Control Diaphragms*
- Control Cables*
- Control Linkages*
- Purge Valves
- Vapor Hoses
- Liquid/Vapor Separator
- Carbon Canister
- Canister Mounting Brackets
- Carburetor Purge Port Connector

*As related to the evaporative emission control system.

Emission-related components also include any other part whose only purpose is to reduce emissions or whose failure will increase emissions without significantly degrading engine/equipment performance. The exclusive remedy for breach of this limited warranty shall be, at the exclusive option of POLARIS, repair or replacement of any defective materials, components or products. THE REMEDIES SET FORTH IN THIS LIMITED WARRANTY ARE THE ONLY REMEDIES AVAILABLE TO ANY PERSON FOR BREACH OF THIS WARRANTY. POLARIS SHALL HAVE NO LIABILITY TO ANY PERSON FOR INCIDENTAL, CONSEQUENTIAL OR SPECIAL DAMAGES OF ANY DESCRIPTION, WHETHER ARISING OUT OF EXPRESS OR IMPLIED WARRANTY OR ANY OTHER CONTRACT, NEGLIGENCE OR OTHER TORT OR OTHERWISE. THIS EXCLUSION OF CONSEQUENTIAL, INCIDENTAL, AND SPECIAL DAMAGES IS INDEPENDENT FROM AND SHALL SURVIVE ANY FINDING THAT THE EXCLUSIVE REMEDY FAILED OF ITS ESSENTIAL PURPOSE.

ALL IMPLIED WARRANTIES (INCLUDING BUT NOT LIMITED TO ANY IMPLIED WARRANTIES OF MERCHANTABILITY AND FITNESS FOR A PARTICULAR PURPOSE) ARE LIMITED IN DURATION TO THE WARRANTY PERIOD DESCRIBED HEREIN. POLARIS DISCLAIMS ALL EXPRESS WARRANTIES NOT STATED IN THIS WARRANTY. Some states do not allow limitations on how long an implied warranty lasts, so the above limitation may not apply if it is inconsistent with the controlling state law.

This limited warranty excludes failures not caused by a defect in material or workmanship. This limited warranty does not cover damage due to accidents, abuse or improper handling, maintenance or use. This limited warranty also does not cover any engine that has been structurally altered, or when the vehicle has been used in racing competition. This limited warranty also does not cover physical damage, corrosion or defects caused by fire, explosions or other similar causes beyond the control of POLARIS.

WARRANTY

Owners are responsible for performing the scheduled maintenance identified in the owner's manual. POLARIS may deny warranty claims for failures that have been caused by the owner's or operator's improper maintenance or use, by accidents for which POLARIS has no responsibility, or by acts of God.

Any qualified repair shop or person may maintain, replace, or repair the emission control devices or systems on your vehicle. An authorized POLARIS dealer can perform any service that may be necessary for your vehicle. POLARIS also recommends POLARIS parts, however equivalent parts may be used for such service. It is a potential violation of the Clean Air Act if a part supplied by an aftermarket parts manufacturer reduces the effectiveness of the vehicle's emission controls. Tampering with emission controls is prohibited by federal law.

CALIFORNIA RESIDENTS

Certain POLARIS Off-Road Vehicles are available in 49-state and 50-state versions. Only the 50-state models are certified for sale in California. The 50-state models available for sale in California are identified by the letter “B” in the ninth position of the model number (e.g., R16RTE87B). The POLARIS 50-state models are designed and built with features such as a reduced cargo box capacity. Any modifications to these features may be a violation of the applicable California regulations and may void this limited emissions warranty offered by the manufacturer.

POLARIS Inc. warrants that at the time is first purchased, this vehicle is:

1. Designed, built, and equipped so as to conform, at the time of sale, with all applicable California evaporative emissions regulations.
2. Free from defects in material and workmanship that may cause the failure of a warranted part as defined in California evaporative emissions regulations. All replacement parts must be identical in all material respects to that part as described in the OHRV manufacturer’s Executive Order of Certification application.

The California evaporative emissions control system limited warranty statement below applies to your Off Highway Recreational Vehicle in California if the vehicle is equipped with an evaporative emission control system and is labeled with a Vehicle Evaporative Emissions Control Information label indicating that the vehicle conforms to California evaporative emissions regulations applicable to new off-road sport vehicles, all-terrain vehicles, or off-road utility vehicles. These vehicles are referred to as “OHRV-EVAP” below.

CALIFORNIA EMISSION CONTROL WARRANTY STATEMENT YOUR WARRANTY RIGHTS AND OBLIGATIONS

The California Air Resources Board and Polaris Industries Inc. are pleased to explain the emission control system warranty on your model year 2018 and newer Off Highway Recreational Vehicle. In California, new off-highway recreational vehicles must be designed, built and equipped to meet the State’s stringent anti-smog standards. Polaris must warrant the emission control system on your OHRV-EVAP for the periods of time listed below provided there has been no abuse, neglect or improper maintenance of your OHRV-EVAP.

Your emission control system may include parts such as the carburetor or fuel injection system, fuel tank, fuel hoses, carbon canister, engine computer and Evaporative Emissions Control System parts listed in the U.S.A. EPA Emissions Limited Warranty. Also included may be hoses, belts, connectors and other emission-related assemblies. Where a warrantable condition exists, Polaris will repair your OHRV-EVAP at no cost to you including diagnosis, parts and labor.

MANUFACTURER’S WARRANTY COVERAGE:

For model year 2018 and newer OHRV-EVAP models.

WARRANTY

For 30 months, or 2500 miles (4023 km), or 250 hours, whichever comes first, except for evaporative components over the OHRV high-priced warranty value, which is covered for 60 months, or 5000 miles (8047 km), or 500 hours, whichever comes first.

If any emission-related part on your OHRV-EVAP is defective, the part will be repaired or replaced by Polaris.

OWNER'S WARRANTY RESPONSIBILITIES:

As the OHRV-EVAP owner, you are responsible for the performance of the required maintenance listed in your owner's manual. Polaris recommends that you retain all receipts covering maintenance on your OHRV-EVAP, but Polaris cannot deny warranty solely for the lack of receipts or for your failure to ensure the performance of a scheduled maintenance.

As an owner you are responsible for presenting your OHRV-EVAP to a Polaris dealer as soon as a problem exists. The warranty repairs should be completed in a reasonable amount of time, not to exceed 30 days.

As an OHRV-EVAP owner, you should also be aware that Polaris may deny you warranty coverage if your OHRV-EVAP or a part has failed due to abuse, neglect, improper maintenance or unapproved modifications.

ADD-ON OR MODIFIED PARTS

An add-on or modified part must be compliant with applicable CARB emission control standards. A violation of this requirement is punishable by civil and/or criminal punishment.

If you have any questions regarding your warranty rights and responsibilities, you should contact Polaris Customer Assistance at 1-800-POLARIS (1-800-765-2747) or the California Air Resources Board at 9528 Telstar Avenue, El Monte, CA 91731.

United States & Canada: 1-800-POLARIS (1-800-765-2747)

French: 1-800-268-6334

A		Diagnostic Display Code
Adding or Changing Coolant	114	Definitions
Air Filter.....	121	165
All Wheel Drive (AWD) System	57	Display Mode.....
Audio Controls (if equipped).....	36	79
Auxiliary Outlets	39	Display Units, Standard/Metric
Axle and Wheel Nut Torque		66
Specifications.....	135	Drive Belt Wear / Burn
		159
B		E
Battery	140	Electromagnetic Interference
Battery Installation	140	87
Battery Maintenance and		Electronic Power Steering (EPS)...
Charging	141	40
Battery Removal.....	140	Engaging AWD
Before You Ride	71	57
Belt Replacement / Debris		Engine Backfires
Removal	117	162
Brake and Throttle Pedals	55	Engine Doesn't Turn Over
Brake Fluid.....	126	161
Brake Inspection	125	Engine Pings or Knocks
Brakes	124	163
Braking	85	Engine Runs Irregularly, Stalls
		or Misfires
		163
		Engine Stops or Loses Power
		164
		Engine Turns Over, Fails to
		Start.....
		161
		Error Codes, Engine.....
		70
		Exhaust Emission Control
		System
		87
C		F
Cab Doors	53	Fluid Change
California Residents	191	103
Check Engine Indicator	70	Fluid Check.....
Component Locations.....	32	102
Coolant		Front / Rear Shock
Adding or Changing	114	Compression Adjustment.....
Cooling System.....	114	132
Crankcase Emission Control		Front / Rear Spring Preload
System	87	Adjustment
		131
		Fuel Level.....
		44
		Fuel Recommendations
		45
		Fuse / Relay Center
		109
D		G
Demand Drive Fluid Change	105	Gear Selector
Demand Drive Fluid Check	105	53
Demand Drive Unit (Front		Gearcase Specification Chart.....
Gearcase)	104	106
Device Compliance Statements	72	
		H
		Headlight Beam Adjustment.....
		138
		Headlight Replacement.....
		137

How To Obtain Warranty Service	186
--------------------------------------	-----

I

Ignition Switch	37
Indicator Lamps	59
Instrument Cluster	58
Intake Pre-Filters	120

L

Lights	137
Limited Warranty	183
Lubrication Recommendations	95

M

Maintenance Log	193
Metric Display	66
Mode Button	59
Mode Information Displays	63

N

Near-field Communication (NFC)	31
Noise Emission Control System	87
Notice	187

O

Oil and Filter Change	99
Oil Check	98
Oil Recommendations	97
Operation on Public Lands in the U.S.A.	87

P

Passenger Hand Hold	43
PDM Fuse Troubleshooting	112

Periodic Maintenance	89
PIN Activated Security System (P.A.S.S.) (if equipped)	
Instrument Cluster	68
Ride Command	76
Polaris Products	157
POLARIS Variable	
Transmission (PVT) System	116
Polishing the Vehicle	144
Preload Settings	
Preload Settings	127
Programmable Service Interval	67
PVT Drying	119

R

Radiator Coolant Level / Changing Coolant	115
Radiators and Cooling Fan	114
Registration	183
Ride Command	
Buttons	74
Driveline Mode	77
Gauge Screens	78
Gauge View Mode	79
Icon Bar	80
Overview	74
Settings	78
Ride Mode Controls (if equipped)	34
Rider Information Center	62
Rollover Protective Structure (ROPS)	56

S

Safe Operating Guidelines	
Stopping the Engine and Parking the Vehicle	86
Safe Operation Practices	
Driving in Reverse	86
Safety	
Driver and Passenger	
Qualifications	10
Driving Guidelines	16
Owner Requirements	9

Preprepare Yourself, Passengers, and Cargo for the Ride	14
Prepare Vehicle for the Ride	11
Safety Labels and Locations	
Air Box Caution	27
Belt Debris Warning	28
Driver Information Warning ...	24-25
Fuel Transport Warning	26
Load / Passenger / Tire Pressure Warning	29
Overview	23
Rear Seat Warning	26
Safety Symbols	4
Seat Adjustments	42
Seat Belts	46
Multi-point Seat Belt	46
Sub Zero Seat Belt Harness	51
Seats	41
Seat Removal	41
Service Access Panels	52
Signal Words	4
Spark Arrester	122
Spark Plug Condition	108
Spark Plug Gap / Torque	107
Spark Plug Removal and Replacement	107
Specifications - Turbo R	151
Specifications - Turbo R 4	154
Spring Preload Adjustment Recommendations	133
Standard Steering Wheel (if equipped)	33
Starting the Engine	85
Steering Wheel Inspection	139
Storage Tips	145
Suspension Settings	127
Switches	
All Wheel Drive (AWD) Switch ...	38
Driveline Mode (AWD) Switch	38
Headlight Switch	38
Mode Button	59

T

Tachometer	58
Taillight / Brake Light Replacement	137

Tires	134
Tire Rotation	134
Tire Tread Depth	134
Tools for Safe Riding	7
Transmission (Main Gearcase) ...	102
Transporting the Vehicle	148

U

U.S.A. EPA Emissions Limited Warranty	188
Update Maps	82
Update Software	81

V

Vehicle Break-in	
Brake System Break-in	83
Engine and Drivetrain Break-in	83
PVT Break-in (Clutches / Belt) ...	84
Vehicle Identification Numbers	8
Vehicle Immersion	139

W

Warning Symbols	4
Warranty Coverage and Exclusions	184
Washing the Vehicle	143
Welcome Page	3
Wheel Installation	136
Wheel Removal	135



For your nearest Polaris dealer,
call 1-800-POLARIS (765-2747)
or visit www.polaris.com

Polaris Inc.
2100 Highway 55
Medina, MN 55340



Part No. 9954282 Rev 02
Printed in USA