

2024



For Maintenance and Safety

OWNER'S MANUAL

Scrambler XP 1000 S

POLARIS
Think Outside

WARNING

Read this manual carefully. It contains important safety information. This is an adult vehicle only.
Operation is prohibited for those under 16 years of age.



WARNING

Read, understand, and follow all of the instructions and safety precautions in this manual and on all product labels.

Failure to follow the safety precautions could result in serious injury or death.



WARNING

Operating, servicing, and maintaining a passenger vehicle or off-road vehicle can expose you to chemicals including engine exhaust, carbon monoxide, phthalates, and lead, which are known to the State of California to cause cancer and birth defects or other reproductive harm. To minimize exposure, avoid breathing exhaust, do not idle the engine except as necessary, service your vehicle in a well-ventilated area and wear gloves or wash your hands frequently when servicing your vehicle.

For more information go to www.P65Warnings.ca.gov/passenger-vehicle.



*For videos and more information
about a safe riding experience with
your Polaris vehicle, scan this QR
code® with your smartphone
or visit: www.polaris.com/en-us/safety/*

POLARIS

2024 Owner's Manual

Scrambler XP 1000 S

Android® is a registered trademark of Google LLC. AUTOLITE® is a registered trademark of BMO HARRIS BANK N. A. BatteryMinder® is a registered trademark of VDC Electronics, Inc. Bluetooth® is a registered trademark of Bluetooth Sig, Inc. iOS® is a registered trademark of Cisco Technology, Inc. MIKUNI® is a registered Trademark of MIKUNI CORPORATION. QR Code® is a registered trademark of DENSO WAVE INCORPORATED. RiderCourseSM is a service trademark of Specialty Vehicle Institute of America. TOP TIER DETERGENT GASOLINE® is a registered trademark of GENERAL MOTORS LLC. Tread LightlySM is a service mark of the United States Department of Agriculture.

Unless noted, trademarks are the property of Polaris Industries Inc.

Copyright 2023 Polaris Industries Inc. All information contained within this publication is based on the latest product information at the time of publication. Due to constant improvements in the design and quality of production components, some minor discrepancies may result between the actual vehicle and the information presented in this publication. Depictions and/or procedures in this publication are intended for reference use only. No liability can be accepted for omissions or inaccuracies. Any reprinting or reuse of the depictions and/or procedures contained within, whether whole or in part, is expressly prohibited.

The original instructions for this vehicle are in English. Other languages are provided as translations of the original instructions.

Printed in U.S.A.

9941614 Rev 02



Thank you for purchasing a POLARIS vehicle, and welcome to our world-wide family of POLARIS enthusiasts. Be sure to visit us online at www.polaris.com for the latest news, new product introductions, upcoming events, career opportunities and more.

Here at POLARIS we proudly produce an exciting line of utility and recreational products. We believe POLARIS sets a standard of excellence for all utility and recreational vehicles manufactured in the world today. Many years of experience have gone into the engineering, design, and development of your POLARIS vehicle, making it the finest machine we've ever produced.

For safe and enjoyable operation of your vehicle, be sure to follow the instructions and recommendations in this owner's manual. Your manual contains instructions for minor maintenance, but information about major repairs is outlined in the POLARIS Service Manual and can be performed by a factory certified Master Service Dealer (MSD) technician.

Your POLARIS dealer knows your vehicle best and is interested in your total satisfaction. Your POLARIS dealership can perform all of your service needs during and after the warranty period.

For the most up-to-date owner's manual visit
<https://www.polaris.com/en-us/owners-manuals>.

SAFETY SYMBOLS AND SIGNAL WORDS

The following signal words and symbols appear throughout this manual and on your vehicle. Your safety is involved when these words and symbols are used. Become familiar with their meanings before reading the manual.

DANGER

DANGER indicates a hazardous situation which, if not avoided, WILL result in death or serious injury.

WARNING

WARNING indicates a hazardous situation which, if not avoided, COULD result in death or serious injury.

CAUTION

CAUTION indicates a hazardous situation which, if not avoided, COULD result in minor to moderate injury.

NOTICE

NOTICE provides key information by clarifying instructions.

IMPORTANT

IMPORTANT provides key reminders during disassembly, assembly, and inspection of components.

The Prohibition Safety Sign indicates an action NOT to take in order to avoid a hazard.



The Mandatory Action Sign indicates an action that NEEDS to be taken to avoid a hazard.



Introduction	7
Safety	11
Features and Controls	29
Operation	57
Winch Guide (If Equipped)	77
Emission Control Systems	87
Maintenance	89
Specifications	143
POLARIS Products	147
Troubleshooting	149
Warranty	159
Maintenance Log	171

INTRODUCTION

IMPORTANT WARNING ABOUT THIS MANUAL

WARNING

Failure to heed the warnings and safety precautions contained in this manual can result in severe injury or death. A POLARIS ATV is not a toy and can be hazardous to operate. This vehicle handles differently than other vehicles, such as motorcycles and cars. A collision or rollover can occur quickly, even during routine maneuvers like turning, or driving on hills or over obstacles, if you fail to take proper precautions.

- Read this owner's manual. Understand all safety warnings, precautions and operating procedures before operating a POLARIS ATV. Keep this manual with the ATV.
- Never operate an ATV without proper instruction. Take a certified ATV safety training course. In the United States, certified training can be found at www.atvsafety.org.
- This vehicle is an **ADULT VEHICLE ONLY**. Operation is prohibited for anyone under 16 years of age.
- Never permit a guest to operate the ATV unless the guest has read this manual and all product labels and has completed a certified safety training course. In the United States, certified training can be found at www.atvsafety.org.

VEHICLE IDENTIFICATION NUMBERS

The vehicle identification number (VIN) is stamped on the right rear frame tube .

Record your vehicle's identification numbers and key number in the spaces provided. Remove the spare key and store it in a safe place. An ignition key can be duplicated only by ordering a POLARIS key blank (using your key number) and mating it with one of your existing keys. The ignition switch must be replaced if all keys are lost.

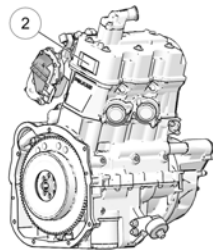
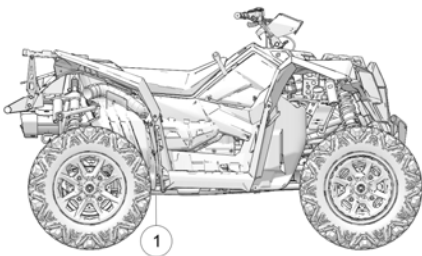

INTRODUCTION

Vehicle Model Number	
Frame VIN ①	
Engine Serial Number ②	
Key Number	

REPLACEMENT KEYS

A replacement key can be made from the original key.

Key Blank:
P/N 4080125

Rubber Key Cover:
P/N 5458344



RADIO COMPLIANCE STATEMENTS

USA RADIO COMPLIANCE

This vehicle may contain the following radio equipment or components that contain radio equipment:

COMPONENT	COMPONENT ID	MANUFACTURER
B1 Gauge	TT-B1B	Polaris Industries Inc.

This device complies with part 15 of the FCC Rules. Operation is subject to the following two conditions: (1) This device may not cause harmful interference, and (2) this device must accept any interference received, including interference that may cause undesired operation.

CAUTION

Changes or modifications not expressly approved by the party responsible for compliance could void the user's authority to operate the equipment.

CANADA RADIO COMPLIANCE

This vehicle may contain the following radio equipment or components that contain radio equipment:

COMPONENT	COMPONENT ID	MANUFACTURER
B1 Gauge	TT-B1B	Polaris Industries Inc.

This device contains license-exempt transmitter(s)/receiver(s) that comply with Innovation, Science and Economic Development Canada's license-exempt RSS (s). Operation is subject to the following two conditions:

1. This device may not cause interference.
2. This device must accept any interference, including interference that may cause undesired operation of the device.

IMPORTANT

For applications that use vehicle-to-vehicle (V2V) communication, radio transmitter IC 5966A-RC7W has been approved by Innovation, Science and Economic Development Canada (ISED) to operate with Polaris antenna (part number 4080356) with gain of 3 dBi. Any antenna that has a gain greater than 3 dBi is prohibited for use with this device.

REPORTING SAFETY DEFECTS (CANADA)

To report a safety defect to Transport Canada, you may either fill out an online defect complaint form at their website (English: <http://www.tc.gc.ca/recalls>, French: <http://www.tc.gc.ca/rappels>) or contact their Defect Investigations and Recalls Division by calling toll-free 1-800-333-0510 (Canada) or 819-994-3328 (Ottawa-Gatineau area / International).

SAFETY

SAFETY TRAINING

ATV safety training is a top priority for POLARIS. POLARIS strongly encourages you and any family members who will be riding the ATV to take a training course.

A POLARIS ATV is an off-road vehicle. Familiarize yourself with all laws and regulations concerning the operation of this vehicle in your area. We strongly advise you to strictly follow the recommended maintenance program outlined in your vehicle manual. This preventive maintenance program is designed to ensure that all critical components on your vehicle are thoroughly inspected at specific intervals.

SAFETY TRAINING IN THE UNITED STATES

If you purchased a new POLARIS ATV in the United States, your dealer provided information about the authorized ATV *RiderCourse*SM that is available to you and your eligible family members. This training is included in the purchase price of your ATV. You were also provided with printed materials that explain safe operating procedures. You should review this information on a regular basis.

If you purchased a used POLARIS ATV in the United States, you can enroll in the ATV *RiderCourse*SM for a fee. Call ATV Enrollment Express at 1-800-887-2887 or visit www.atvsafety.org. If you purchased a POLARIS ATV outside the United States, please contact your dealer or local law enforcement agencies, or visit www.polaris.com for information about safety training.

FOR MORE INFORMATION ABOUT ATV SAFETY in the United States, call the Consumer Product Safety Commission at 1-800-638-2772, or visit www.cpsc.gov, visit www.atvsafety.org, or call POLARIS at 1-800-342-3764.

SAFE RIDING GEAR

Always wear helmet, eye protection, gloves, long-sleeve shirt, long pants, and over-the-ankle boots at all times. Protective gear reduces the chance of injury.

- ① Helmet
- ② Eye Protection
- ③ Long Sleeves
- ④ Gloves
- ⑤ Long Pants
- ⑥ Over-the-Ankle Boots



SAFETY

HELMET

Wearing a helmet can prevent a severe head injury. Whenever riding this POLARIS vehicle, always wear a helmet that meets or exceeds established safety standards. Clasp the buckle and pull each strap tight to ensure the helmet is properly secured to the head.

Approved helmets in the USA and Canada bear a U.S. Department of Transportation (DOT) label.



Approved helmets in Europe, Asia and Oceania bear the ECE 22.05 label. The ECE mark consists of a circle surrounding the letter E, followed by the distinguishing number of the country which has granted approval. The approval number and serial number will also be displayed on the label.



EYE PROTECTION

Do not depend on eyeglasses or sunglasses for eye protection. Whenever riding this POLARIS vehicle, always wear shatterproof goggles or use a shatterproof helmet face shield. POLARIS recommends wearing approved Personal Protective Equipment (PPE) bearing markings such as VESC 8, V-8, Z87.1, or CE. Make sure protective eye wear is kept clean.

GLOVES

Wear gloves for comfort and for protection from sun, cold weather and other elements.

BOOTS

Wear sturdy over-the-ankle boots for support and protection. Never ride a POLARIS vehicle with bare feet or sandals.

CLOTHING

Wear long sleeves and long pants to protect arms and legs.

SAFETY WARNINGS

WARNING

Failure to operate this vehicle properly can result in a collision, loss of control, accident or rollover, which may result in serious injury or death. Heed all safety warnings outlined in this section of the owner's manual. See the operation section of this owner's manual for proper operating procedures.

OPERATING WITHOUT INSTRUCTION

Operating this ATV without proper instruction increases the risk of an accident. The operator must understand how to operate the ATV properly in different situations and on different types of terrain.

Beginning and inexperienced operators should complete the recommended safety training before operating this vehicle.

Never permit a guest to operate the ATV unless the guest has read this manual and all product labels and has completed a certified safety training course.



AGE RESTRICTIONS

This vehicle is an ADULT VEHICLE ONLY. Operation is prohibited for anyone under 16 years of age.

Never allow anyone under 12 years of age to ride as a passenger on a 2-up ATV.

Even though a child may be within the recommended age group for operating some ATVs, they may not have the skills, abilities, or judgment needed to operate or ride on this ATV safely and could be susceptible to accident or injury.



SAFETY

USING ALCOHOL OR DRUGS

Never consume alcohol or drugs before or while operating this vehicle.

Operating this vehicle after consuming alcohol or drugs could adversely affect operator judgment, reaction time, balance and perception.



FAILURE TO INSPECT BEFORE OPERATING

WARNING

Failure to inspect and verify that the vehicle is in safe operating condition before operating increases the risk of an accident.

Always perform the pre-ride inspection before each use of your vehicle to make sure it's in safe operating condition.

Always follow the inspection and maintenance procedures and schedules described in this owner's manual.

HANDLING GASOLINE

Gasoline is highly flammable and explosive under certain conditions.

- Always exercise extreme caution whenever handling gasoline.
- Always refuel with the engine stopped, and outdoors or in a well ventilated area.
- Never carry fuel or other flammable liquids on this vehicle. Failure to follow this instruction could lead to serious burn injuries or death.
- Do not smoke or allow open flames or sparks in or near the area where refueling is performed or where gasoline is stored.
- Do not overfill the tank. Do not fill the tank neck.
- If gasoline spills on your skin or clothing, immediately wash it off with soap and water and change clothing.

EXPOSURE TO EXHAUST



Engine exhaust fumes are poisonous and can cause loss of consciousness or death in a short time. Never start the engine or let it run in an enclosed area. Operate this vehicle only outdoors or in well-ventilated areas.

PROTECTIVE APPAREL

Riding in this vehicle without wearing an approved helmet and protective eye wear increases the risk of a serious injuries in the event of an accident.

Always wear a helmet, eye protection, gloves, long-sleeve shirt, long pants and over-the-ankle boots.



OPERATING ON PAVEMENT

This vehicle's tires are designed for off-road use only, not for use on pavement. Operating this vehicle on paved surfaces (including sidewalks, paths, parking lots and driveways) may adversely affect the handling of the vehicle and may increase the risk of loss of control and accident or rollover. Avoid operating the vehicle on pavement. If it's unavoidable, travel slowly, travel short distances and avoid sudden turns or stops.

OPERATING ON PUBLIC ROADS

Operating this vehicle on public streets, roads or highways could result in a collision with another vehicle. Never operate this vehicle on any public street, road or highway, including dirt and gravel roads (unless designated for off-highway use).



SAFETY

OPERATING AT EXCESSIVE SPEEDS

Operating this vehicle at excessive speeds increases the operator's risk of losing control. Always operate at a speed that's appropriate for the terrain, the visibility and operating conditions and your skills and experience.



PHYSICAL CONTROL OF THE VEHICLE

Removing even one hand or foot can reduce ability to control the vehicle or could cause loss of balance and ejection from the ATV.

If a person's feet are not firmly planted on the footrests, they could come into contact with the wheels or other moving parts and lead to accident or injury.

Always keep both hands on the handlebars and both feet on the footrests of the ATV during operation.

TURNING IMPROPERLY

 CAUTION

Turning improperly could cause loss of traction, loss of control, accident or rollover. Always follow proper procedures for turning as described in this owner's manual.

Avoid sharp turns. Never turn while applying heavy throttle. Never make abrupt steering maneuvers. Practice turning at slow speeds before attempting to turn at faster speeds.

JUMPS AND STUNTS

Exhibition driving increases the risk of an accident or rollover. **DO NOT** do power slides, "donuts", jumps or other driving stunts. Avoid exhibition driving.



IMPROPER HILL CLIMBING

Improper hill climbing could cause loss of control or rollover. Use extreme caution when operating on hills. Always follow proper procedures for hill climbing as described in this owner's manual. See the New Operator Driving Procedures section for details.

DESCENDING HILLS IMPROPERLY

Improperly descending a hill could cause loss of control or rollover. Always follow proper procedures for traveling down hills as described in this owner's manual. See the New Operator Driving Procedures section for details.

CROSSING HILLSIDES

Driving on a sidehill is not recommended. Improper procedure could cause loss of control or rollover. Avoid crossing the side of any hill unless absolutely necessary.

If crossing a hillside is unavoidable, always follow proper procedures as described in this owner's manual. See the New Operator Driving Procedures section for details.

SAFETY

STALLING WHILE CLIMBING A HILL

Stalling, rolling backwards or improperly dismounting while climbing a hill could cause a rollover.

- Always maintain a steady speed when climbing a hill.
- Always engage ADC mode (if equipped) before ascending or descending a hill. If ADC mode is not equipped, apply AWD mode before ascending or descending a hill.



If all forward speed is lost:

- Lean forward to keep body weight uphill.
- Apply the brakes.
- Lock the parking brake when fully stopped.
- Dismount on the uphill side of the vehicle, or on the left if the vehicle is pointing straight uphill.
- Turn the ATV around and remount, following the procedure described in the owner's manual.

If the ATV begins rolling downhill:

- Keep operator body weight uphill.
- Never apply engine power.
- Apply the brake lever gradually.
- When fully stopped, apply the auxiliary brake as well, and then lock the parking brake.
- Dismount on the uphill side of the vehicle, or on the left if the vehicle is pointing straight uphill.
- Turn the ATV around and remount, following the procedure described in the owner's manual.

OPERATING ON STEEP HILLS

Operating on excessively steep hills could cause an overturn.

Never operate on hills too steep for the ATV or for your abilities.

Never operate this ATV on hills steeper than 25 degrees.



OPERATING ON SLIPPERY TERRAIN

Failure to use extra caution when operating on excessively rough, slippery or loose terrain could cause loss of traction, loss of control, accident or overturn.

Do not operate on excessively rough, slippery or loose terrain until you've learned and practiced the skills necessary to control the vehicle on such terrain.

Always use extra caution on rough, slippery or loose terrain.



OPERATING IN UNFAMILIAR TERRAIN

Failure to use extra caution when operating on unfamiliar terrain could result in an accident or rollover.

Unfamiliar terrain may contain hidden rocks, bumps, or holes that could cause loss of control or rollover.

Travel slowly and use extra caution when operating on unfamiliar terrain. Always be alert to changing terrain conditions.

SAFETY

IMPROPER TIRE MAINTENANCE

Operating this vehicle with improper tires or with improper or uneven tire pressure could cause loss of control or accident.

Always use the size and type of tires specified for your vehicle.

Always maintain proper tire pressure as described in the owner's manual and on safety labels.



OPERATING IMPROPERLY IN REVERSE

Improperly operating in reverse could result in a collision with an obstacle or person. Always follow proper operating procedures as outlined in this manual. See the New Operator Driving Procedures section for details.

Before shifting into reverse gear, always check for obstacles or people behind the vehicle. When it's safe to proceed, back slowly.

OPERATING OVER OBSTACLES

Improperly operating over obstacles could cause loss of control or rollover.

Before operating in a new area, check for obstacles. Avoid operating over large obstacles such as large rocks and fallen trees. Always follow the proper procedures outlined in this manual when operating over obstacles. See the New Operator Driving Procedures section for details.



SKIDDING OR SLIDING

Failure to use extra caution when operating on excessively rough, slippery or loose terrain could cause loss of traction, loss of control, accident or rollover. Do not operate on excessively slippery surfaces. Always slow down and use additional caution when operating on slippery surfaces.

Skidding or sliding due to loss of traction can cause loss of control or rollover (if tires regain traction unexpectedly). Always follow proper procedures for operating on slippery surfaces as described in this owner's manual. See the New Operator Driving Procedures section for details.



OPERATING A DAMAGED VEHICLE

CAUTION

Operating a damaged vehicle can result in an accident. After any rollover or other accident, have a qualified service dealer inspect the entire machine for possible damage, including (but not limited to) brakes, throttle, and steering systems.

OPERATING THROUGH WATER

Operating through deep or fast-flowing water can cause loss of traction, loss of control, rollover or accident. Never operate in fast-flowing water or in water that exceeds the floor level of the vehicle.

Always follow proper procedures for operating in water as described in this owner's manual.

Wet brakes may have reduced stopping ability. After leaving water, test the brakes. Apply them lightly several times while driving slowly. The friction will help dry out the pads.

SAFETY

IMPROPER CARGO LOADING

Overloading the vehicle or carrying cargo improperly may cause changes in stability and handling, which could cause loss of control or an accident.

- Always follow the instructions in this owner's manual for carrying cargo.
- Never exceed the stated load capacity for this vehicle.
- Cargo should be properly distributed and securely attached.
- Reduce speed when carrying cargo or pulling a trailer. Allow a greater distance for braking.

OPERATING ON FROZEN BODIES OF WATER

Severe injury or death can result if the vehicle and/or the operator fall through the ice. Never operate the vehicle on a frozen body of water unless you have first verified that the ice is sufficiently thick to support the weight and moving force of the vehicle, you and your cargo, together with any other vehicles in your party.

Always check with local authorities and residents to confirm ice conditions and thickness over your entire route. Vehicle operators assume all risk associated with ice conditions on frozen bodies of water.

POOR VISIBILITY



Operating this vehicle in darkness or inclement weather could result in a collision or accident, especially if operating on a road or street. This vehicle is not equipped with highway-approved lights. Operate this vehicle off-road only. Use caution and drive at reduced speeds in conditions of reduced visibility such as fog, rain and darkness. Clean headlights frequently and replace burned out headlamps promptly.

PHYSICAL SKILLS

Safe operation of this rider-active vehicle requires good judgment and physical skills. Persons with cognitive or physical disabilities who operate this vehicle have an increased risk of overturn and loss of control.

HOT EXHAUST SYSTEMS

WARNING

Exhaust system components are very hot during and after use of the vehicle. Hot components can cause burns and fire. Do not touch hot exhaust system components. Always keep combustible materials away from the exhaust system.

Use caution when traveling through tall grass, especially dry grass and when traveling through muddy conditions. Always inspect the underside of the vehicle and areas near the exhaust system after driving through tall grass, weeds, brush, other tall ground cover, and muddy conditions. Promptly remove any grass, debris or foreign matter clinging to the vehicle and pay particular attention to the exhaust system area.

TRAILER HITCH WARNING (IF EQUIPPED)

If using a hitch, ensure the receiver does not exceed a two inch drop or raise.

WARNING

When trailering with your ATV, be aware that the exhaust is located above the hitch ball receiver and the trailer hitch. During operation of the ATV, the exhaust will produce hot exhaust gas that should not be inhaled and that may elevate the surface temperature of surrounding surfaces, including trailer surfaces (e.g., trailer hitch, trailer tongue, trailer walls, . . . etc.). To reduce the risk of inhaling exhaust gases and to avoid risk of burn or injury, shut off your engine and allow time for the exhaust gases to dissipate and for the surfaces surrounding the exhaust to cool, including the trailer surfaces, before connecting or disconnecting a trailer. To reduce the potential for the trailer hitch or trailer tongue from getting too hot, do not use a receiver hitch with a rise of more than two inches.

UNAUTHORIZED USE OF THE VEHICLE

Leaving the keys in the ignition can lead to unauthorized use of the vehicle by someone under the age of 16, without a drivers license, or without proper training. This could result in an accident or rollover. Always remove the ignition key when the vehicle is not in use.

SAFETY

EQUIPMENT MODIFICATIONS

Your POLARIS vehicle is designed to provide safe operation when used as directed. Modifications to your vehicle may negatively impact vehicle stability. Failure of critical machine components may result from operation with any modifications, especially those that increase speed or power. This vehicle may become less stable at speeds higher than those for which it is designed. Loss of control may occur at higher speeds.

Do not install any non-POLARIS-approved accessory or modify the vehicle for the purpose of increasing speed or power. Any modifications or installation of non-POLARIS-approved accessories could create a substantial safety hazard and increase the risk of bodily injury.

The POLARIS limited warranty on your POLARIS vehicle will be terminated if any non-POLARIS approved equipment and/or modifications have been added to the vehicle that increase speed or power.

The addition of certain accessories, including (but not limited to) mowers, blades, tires, sprayers, or large racks, may change the handling characteristics of the vehicle. Use only POLARIS-approved accessories, and familiarize yourself with their function and effect on the vehicle.

For more information about ATV safety, see the Safety Training section.

SAFETY LABELS AND LOCATIONS

Warning labels have been placed on the vehicle for your protection. Read and follow the instructions on each label carefully. If any of the labels shown in this manual differ from the labels on your vehicle, always read and follow the instructions of the labels on the vehicle.

If an informational or graphic label becomes illegible or comes off, contact your POLARIS dealer to purchase a replacement. Replacement safety labels are provided by POLARIS at no charge. The part number is printed on the label.

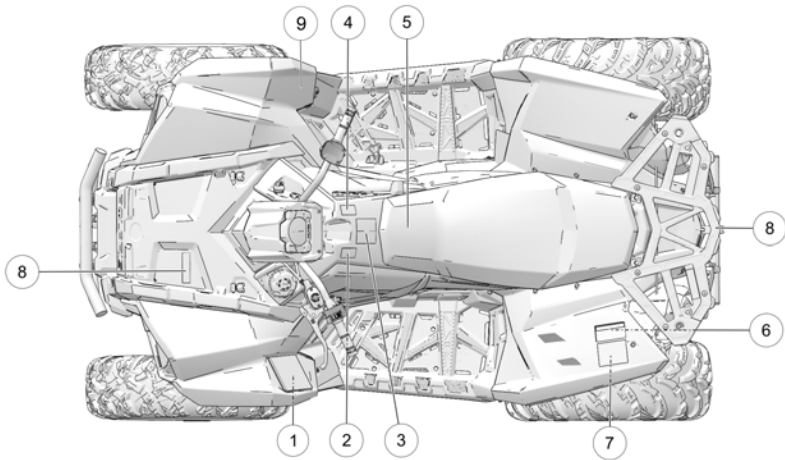

- | | |
|-------------------------------------|--------------------------------|
| ① General Warning | ⑥ No Passenger Warning |
| ② Reverse Override Warning | ⑦ Tire Pressure / Load Warning |
| ③ Age Warning | ⑧ Rack Warning |
| ④ 4x4 (AWD) Caution | ⑨ Discretionary Warning |
| ⑤ Clutch Cover Warning (Under Seat) | |

SAFETY

GENERAL WARNING

WARNING

Improper use can result in SEVERE INJURY or DEATH

ALWAYS USE AN APPROVED HELMET AND PROTECTIVE GEAR

NEVER USE ON PUBLIC ROADS

NEVER CARRY PASSENGERS

NEVER USE WITH DRUGS OR ALCOHOL

NEVER operate:

- without proper training or instruction
- at speeds too fast for your skills or the conditions
- on public roads - a collision can occur with another vehicle
- with a passenger - passengers affect balance and steering and increase risk of losing control

ALWAYS:

- use proper riding techniques to avoid vehicle overturns on hills and rough terrain and in turns
- avoid paved surfaces - pavement may seriously affect handling and control

Locate and Read Owner's Manual. Follow All Instructions And Warnings.

Part Number: 7186136

REVERSE OVERRIDE WARNING

WARNING

Improper use of override button can lead to loss of control resulting in severe injury or death. Do not activate override while throttle is engaged. Always apply throttle gradually while in reverse.

Part Number: 7186127

AGE 16 WARNING

WARNING

Operating this ATV if you are under the age of 16 increases your chance of severe injury or death.

NEVER operate this ATV if you are under age 16.

Part Number: 7185253

4X4 (AWD) CAUTION

CAUTION

Do not push switch to engage 4x4 (AWD) if the rear wheels are spinning. This may cause severe drive shaft and clutch damage.

Part Number: 7186126

CLUTCH COVER WARNING

WARNING

- Moving parts hazard under belt-clutch guard. To prevent serious injury, do not operate vehicle with guard removed.
- Do not modify engine or clutch. Doing so can cause part failure, possible imbalance, and excessive engine RPM, which can result in serious injury or death.

Part Number: 7175488

NO PASSENGER WARNING

WARNING

NEVER ride as a passenger. Passengers can cause a loss of control, resulting in SEVERE INJURY or DEATH.

Part Number: 7186125

TIRE PRESSURE / LOAD WARNING

WARNING

Improper tire pressure or overloading can cause loss of control. Loss of control can result in severe injury or death.

- Cold tire pressure:
 - Front: 7.0 psi (48.3 kPa)
 - Rear: 7.0 psi (48.3 kPa)
- Maximum weight capacity: 290 lbs. (131 kg)
- Lug nut torque values: Reference Owner's Manual

Part Number: 7300104

SAFETY

RACK WARNING

WARNING

- DO NOT TOW FROM RACK OR BUMPER.

Vehicle damage or tipover may result causing severe injury or death. Tow only from tow hooks or hitch.

- Maximum Rack Loads:
 - Front: 25 lbs. (11 kg)
 - Rear: 50 lbs. (23 kg)

Part Number: 7179093

DISCRETIONARY WARNING

WARNING

- Never operate this ATV on hills steeper than 25 degrees. To prevent overturn on hilly terrain, use throttle and brakes gradually, and shift weight uphill.
- REVERSE operation can be dangerous even at low speeds. Steering becomes difficult. To prevent loss of control, avoid sudden braking or sharp turns.

Part Number: 7186138

FEATURES AND CONTROLS OVERVIEW

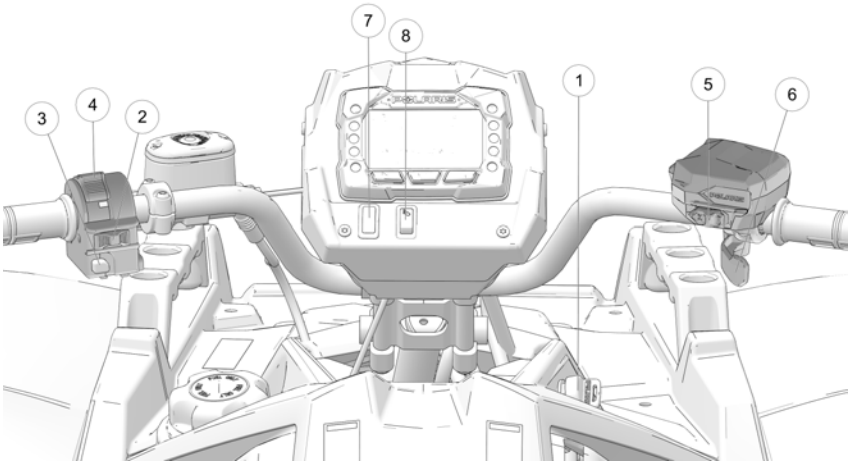

- ① Key Ignition Switch
- ② Engine Stop Switch
- ③ Mode/Reverse Override Switch
- ④ Headlight Switch
- ⑤ Driveline Switch
- ⑥ Throttle Lever
- ⑦ Drive Mode Switch
- ⑧ LED Light Switch

IGNITION SWITCH/LIGHT SWITCH

Use the ignition switch to start the engine. The key can be removed from the switch when it is in the OFF position.

OFF	Turn the key to the OFF position to stop the engine. Electrical circuits are off.
RUN	Turn the key the RUN position to activate electrical components. Electrical circuits are on. Electrical equipment can be used.
START	Turn the key to the START position to engage the electric starter. See the Starting the Engine section for starting procedures.

FEATURES AND CONTROLS

LEFT-HAND CONTROL

ENGINE STOP SWITCH

Move the stop switch ② either left or right to the OFF position to stop the engine quickly.

Move the stop switch to the RUN position before attempting to start the engine. The engine will not start or run when the switch is off. Both the main switch and the engine stop switch will shut off all electrical power to the vehicle, including lights.

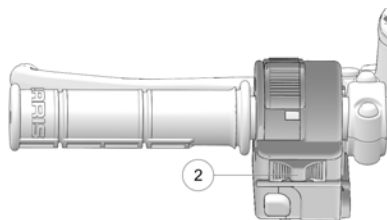

MODE/REVERSE OVERRIDE SWITCH



WARNING

Pressing the override button while the throttle is open can cause loss of control, which may result in serious injury or death. Always release the throttle before pressing the override button.

This vehicle is equipped with a reverse speed limiter system. To gain additional wheel speed while backing, release the throttle and depress the override button ③. The reverse override button also acts as a MODE button when held down for approximately one half second. The override button will not function as a MODE button if the transmission is in reverse.

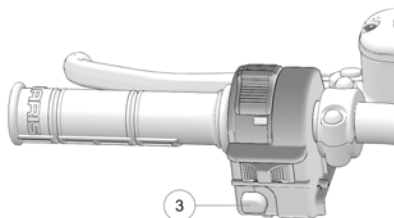

HEADLIGHT SWITCH

Use the headlight switch to turn the lights on and off and to change the lights from high beam to low beam. The key must be in the ON position and the engine stop switch must be in the RUN position.

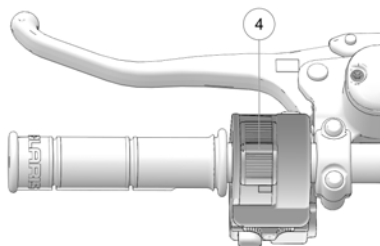

RIGHT-HAND CONTROL

DRIVELINE SWITCH

The All Wheel Drive (AWD) system is controlled by the AWD Momentary Switch ⑤. Use this switch to change the driveline modes between AWD and 2X4. The vehicle automatically engages AWD when operating in reverse if the driveline mode is set to AWD.

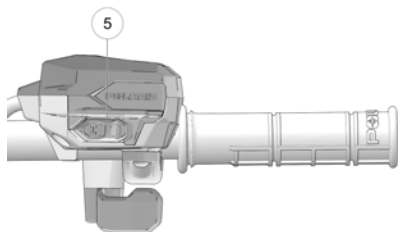

THROTTLE LEVER

WARNING

Operating an ATV with sticking or improperly operating throttle controls could cause an accident. Never start or operate an ATV that has a sticking or improperly operating throttle. Immediately contact your POLARIS dealer or other qualified person for service if throttle problems arise.

Failure to check or maintain proper operation of the throttle system can result in an accident if the throttle lever sticks during operation. Always check the lever for free movement and return before starting the engine. Also check occasionally during operation.

Modifications to the electronic throttle control could result in failure to perform as designed, which could result in an accident. Do not attempt to modify the throttle control system or replace it with any after market throttle mechanisms.

Engine speed and vehicle movement are controlled by pressing the throttle lever ⑥. The throttle lever is spring loaded. Engine speed returns to idle when the lever is released. This ATV is equipped with a throttle release switch, which is designed to reduce the risk of a frozen or stuck throttle.

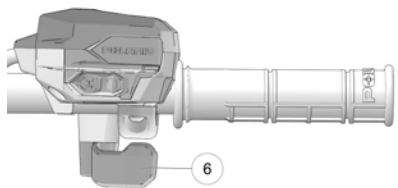

FEATURES AND CONTROLS

DRIVE MODE SWITCH

The Drive Mode Switch has two positions:

- Performance (PERF)
- Standard (STND)

Always use low gear for any of the following conditions regardless of the selected throttle control setting.

- Operating in rough terrain or over obstacles.
- Loading the vehicle onto a trailer.
- Towing heavy loads.
- Driving frequently at low RPM or at ground speeds below 7 MPH (11 km/h).

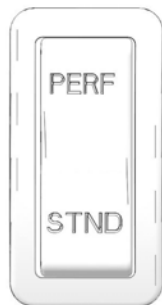

PERFORMANCE MODE

Offers a more aggressive feel to the power of the vehicle. Vehicle will accelerate harder with less throttle movement.

STANDARD MODE

Use for majority of driving.

BRAKE SYSTEM

BRAKE LEVER

WARNING

Operating the ATV with a spongy brake lever can result in loss of braking, which could cause an accident. Never operate the ATV with a spongy-feeling brake lever. Always contact your dealer for service before operating the vehicle.

Squeeze the brake lever ① toward the handlebar to apply the front and rear brakes. These brakes are hydraulically activated disc type brakes that are activated by only one lever. Always test brake lever travel and master cylinder fluid level before riding. When squeezed, the lever should feel firm. Any sponginess would indicate a possible fluid leak or low master cylinder fluid level, which must be corrected before riding.

Contact your POLARIS dealer or other qualified service facility for proper diagnosis and repairs.

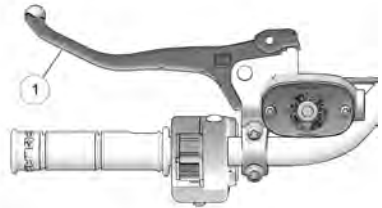

NOTICE



The hand brake lever controls both the front and rear brakes. Always squeeze the hand brake whenever using the auxiliary foot brake.

PARKING BRAKE

LOCKING THE PARKING BRAKE

WARNING

Operating the ATV while the parking brake is engaged could result in an accident or fire. Always check to be sure the parking brake is disengaged before operating.

1. Place the transmission in PARK.
2. Squeeze and release the brake lever  two or three times, then squeeze and hold.
3. Push the parking brake lock  forward to engage the lock.
4. Release the brake lever.
5. To release the parking brake lock, squeeze and release the brake lever. It will return to its unlocked position.

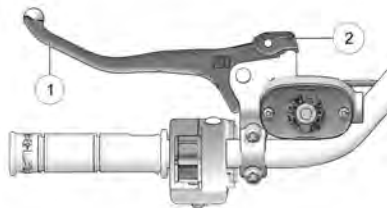

WARNING

The parking brake may relax if left on for a long period of time. Always block the wheels to prevent rolling. Always block the wheels on the downhill side of the ATV if leaving it parked on a hill. Another option is to park the ATV in a sidehill position. Never depend on the parking brake alone if the ATV is parked on a hill.

MASTER CYLINDER / BRAKE FLUID

⚠ WARNING

An over-full master cylinder may cause brake drag or brake lock-up, which could result in an accident. Maintain brake fluid at the recommended level. Do not overfill.

Never store or use a partial bottle of brake fluid. Brake fluid is hygroscopic, meaning it rapidly absorbs moisture from the air. The moisture causes the boiling temperature of the brake fluid to drop, which can lead to early brake fade and the possibility of brake failure, which could result in an accident. After opening a bottle of brake fluid, always discard any unused portion.

Check the brake fluid in the master cylinder before each ride.

1. Position the ATV on a level surface.
2. Position the handlebars so the master cylinder ① is level.

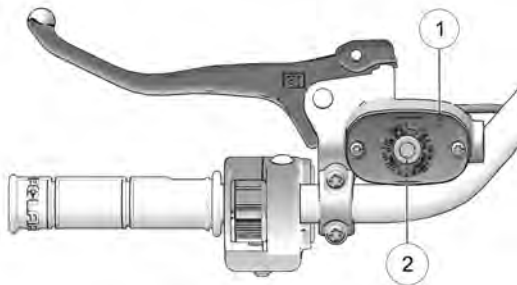

3. View the brake fluid level through the indicator window ② on the top of the master cylinder. The eye will appear dark when the fluid level is full. When fluid is low, the eye will be clear.
4. If the fluid level is low, remove the cover screws and add fluid to the fill line. *Do not overfill.* Use DOT 4 brake fluid only.
5. Reinstall the cover. Torque the screws to specification.

TORQUE

Brake Fluid Reservoir Cover Screws:
7 in-lbs (1 N·m)

IMPORTANT

Always properly break in the brake system of a new ATV or newly-installed brake pads. See the Operation chapter for more information about brake system break-in procedure.

FEATURES AND CONTROLS

AUXILIARY FOOT BRAKE

WARNING

Never back down a hill. Applying the auxiliary brake when backing down a hill may cause tipover, which could result in serious injury or death. Use caution when applying the auxiliary brake. Do not aggressively apply the auxiliary brake when going forward. The rear wheels may skid and slide sideways, causing loss of control and serious injury or death.

The auxiliary brake system is intended to be used as a backup for the main brake system. Should the main system fail, use the auxiliary foot brake ①. The foot brake applies brake pressure to the rear wheels. If using the foot brake, squeeze the hand brake simultaneously to prevent tipover.

The auxiliary foot brake is located on the inside of the right footrest. Operate this brake with your right foot. If the rear wheels slide while using the auxiliary brake, *reduce* brake pedal pressure to brake the rear wheels without skidding.

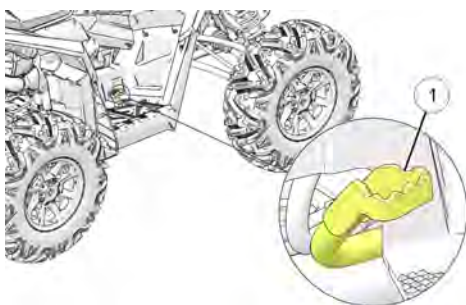

NOTICE

Operating a new vehicle or a vehicle with new brake pads requires a break-in period to prevent brake pad or rotor damage. For brake system break-in information, see the Operation chapter.

BRAKE FLUID LEVEL

Check the brake fluid level frequently for the auxiliary brake system. The reservoir is located under the front rack.

Maintain the fluid level between the maximum and minimum marks. Use DOT 4 brake fluid only.

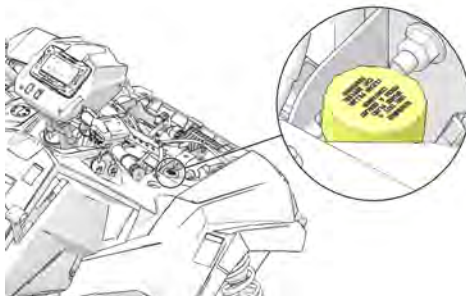

FUEL CAP

NOTICE

Never use fuel blends with more than 10% ethanol. Engine damage could occur.

Always refuel with the engine stopped, and outdoors or in a well ventilated area. Refuel on a level surface.

Remove the fuel tank cap ① and add fuel. Use unleaded gasoline with a minimum pump octane number of 87= (R+ M)/2 octane. *Do not use fuel with ethanol content greater than 10%, such as E-85 fuel.*

The fuel tank is designed to allow for the normal expansion of fuel. Do not overfill. Do not fill the tank neck.

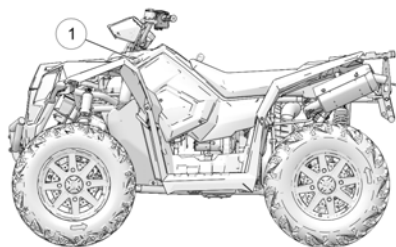

ELECTRONIC POWER STEERING (EPS) (IF EQUIPPED)

Electronic power steering (EPS), if equipped, engages when the ignition key is turned to the ON position. EPS remains engaged whether the vehicle is moving or idle. See the Instrument Cluster section for EPS Warning Indicator information.

NOTICE

Never switch EPS modes while the vehicle is in motion. Ensure the vehicle is fully stopped and no force is applied to the steering system before switching EPS modes.

EPS has three modes: high, medium, low. To set the EPS mode, do the following.

1. Stop the ATV and put it in PARK.
2. Press and hold the MODE button to enter the Options Menu. "OPTIONS" will display on the screen for 3 seconds before showing the first menu item.
3. Select "EPS" from the Options Menu by pressing the MODE button.
4. Toggle the Up/Down Buttons to choose between the high, medium, and low modes.
5. Press the MODE button to lock in the EPS setting.



FRONT COMPARTMENT

To gain access to the front compartment, release the front rack latches ① and remove the rack. To reinstall the rack, hold the rack as shown in the illustration. Position the front edge in the tabs, then push the rack downward and secure the latches.

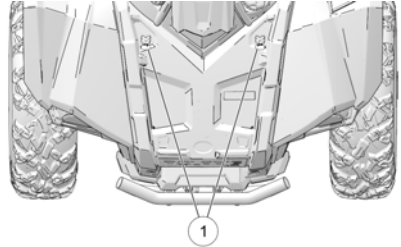

Access the following components in the front compartment:

- Radiator cap
- Brake fluid reservoir
- Battery
- Coolant recovery bottle cap
- Electrical/fuse/relay components

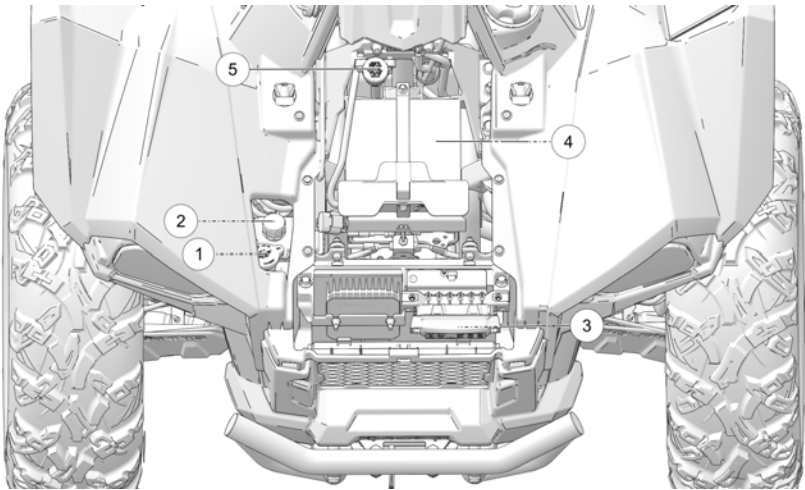

① Radiator Cap

② Coolant Bottle Cap

③ Electrical/Fuse/Relay

④ Battery

⑤ Brake Fluid Reservoir

FEATURES AND CONTROLS

AUTOMATIC TRANSMISSION GEAR SELECTOR

The transmission gear selector ① is located on the right side of the vehicle.

H: High Gear

L: Low Gear

N: Neutral

R: Reverse

P: Park

To shift gears, brake to a complete stop. When the engine is idling, move the lever to the desired gear.

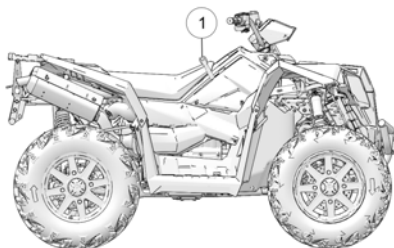

NOTICE

Shifting gears with the engine speed above idle or while the vehicle is moving could cause transmission damage.

Whenever the ATV is left unattended, always place the transmission in PARK and lock the parking brake.

BELT LIFE

To extend belt life, use low forward gear when pulling a heavy load at less than 7 mph (11 km/h) for extended periods and when operating uphill at a slow speed.

ALL WHEEL DRIVE SYSTEM

The All Wheel Drive (AWD) system is controlled by the AWD Momentary Switch ①.

Engage AWD before getting into conditions where front wheel drive may be needed. If the rear wheels are spinning, release the throttle before switching to AWD.

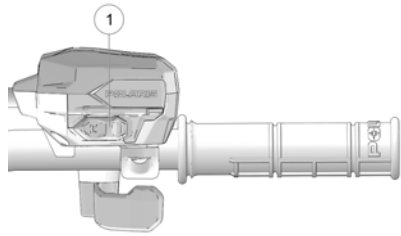

- Push the momentary switch to the right to engage AWD mode.
- Push the momentary switch to the right twice, to engage ADC AWD mode (if equipped).
- Push the momentary switch to the left to operate in two-wheel drive (2X4) mode.

NOTICE

Switching to AWD or ADC AWD (if equipped) while the rear wheels are spinning may cause severe drive shaft and gearcase damage. Always switch to AWD or ADC AWD (if equipped) while the rear wheels have traction or are at rest.

AWD MODE

To engage AWD mode, push the momentary switch to the right. AWD will engage when engine speed slows to below 3100 RPM. The gauge will display "AWD."

There is no limit to the length of time the vehicle may remain in AWD. The vehicle automatically engages AWD when operating in reverse if the switch is set to the AWD position.

Once enabled, AWD remains enabled until the switch is turned off. If the switch is turned off while the demand drive unit is moving, it will not disengage until the rear wheels regain traction.

When in AWD, the demand drive unit will automatically engage any time the rear wheels lose traction. When the rear wheels regain traction, the demand drive unit will automatically disengage.

2X4 MODE

To engage 2x4 Mode, push the momentary switch to the left. AWD will disengage when engine speed slows to below 3100 RPM. The gauge will display "2X4."

FEATURES AND CONTROLS

INSTRUMENT CLUSTER

NOTICE

Features vary by model.

Your vehicle is equipped with one of two available gauge variants, (1) a standard gauge (no Bluetooth® functionality) and (2) a Bluetooth®-equipped gauge. If your gauge is equipped with Bluetooth®, the Bluetooth® icon will briefly display in the upper right corner of the gauge at start-up.

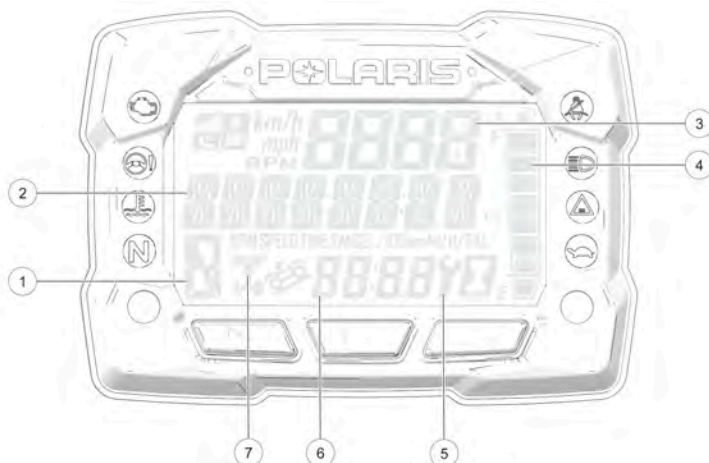

NOTICE







The use of a high pressure washer may damage the instrument cluster. Wash the vehicle by hand or with a garden hose using mild soap. Do not use alcohol to clean the instrument cluster. Do not allow insect sprays to contact the lens. Immediately clean off any gasoline that splashes on the instrument cluster.

FEATURES AND CONTROLS

DISPLAY AREA	FUNCTION
① Gear Indicator	H = High Gear L = Low Gear N = Neutral R = Reverse Gear P = Park – = Gear Signal Error (or shifter between gears)
② Display Area 2	This area displays odometer, trip meter, trip meter 2, voltage, engine temperature, engine hour meter, programmable service hour interval, ground speed, engine RPM, geofence status, or speed limit status. Press the mode button on the left hand control to toggle through the available options.
③ Display Area 1	This area displays engine RPM, ground speed, or coolant temperature.
④ Fuel Gauge	The segments of the fuel gauge show the level of fuel in the fuel tank. When the last segment clears, a low fuel warning is activated. All segments including the fuel icon will flash. Refuel immediately.
⑤ Service Indicator	A flashing wrench symbol alerts the operator that the preset service interval has been reached. Your POLARIS dealer can provide scheduled maintenance. See page 54 for more information.
⑥ Clock (if equipped)	The clock displays time in a 12-hour or 24-hour format.
⑦ AWD Indicator	Segments of the indicator illuminate based on drive mode engaged.

FEATURES AND CONTROLS

INDICATOR LAMPS

INDICATOR	ICON	FUNCTION
Check Engine		This indicator appears if an EFI-related fault occurs. Do not operate the vehicle if this warning appears. Serious engine damage could result. Your authorized POLARIS dealer can assist.
EPS Warning (if equipped)		This lamp illuminates to indicate that the EPS has powered down. This occurs when the engine is OFF but the key is left in the ON position for at least 5 minutes. Cycle the key off and back on to restore function and turn off lamp.
Engine Hot		This lamp illuminates to indicate an overheated engine. If the indicator flashes, a severe overheating condition exists.
Neutral		This lamp illuminates when the transmission is in neutral and the ignition key is in the ON position.
Helmet/Seat Belt		This lamp flashes for several seconds when the key is turned to the ON position. The lamp is a reminder to wear helmet and seat belt (if equipped) before operating.
High Beam		This lamp illuminates when the headlamp switch is set to high beam.

DISPLAY AREA 1

Pressing the MODE button will change the information displayed in Area 1 ①.

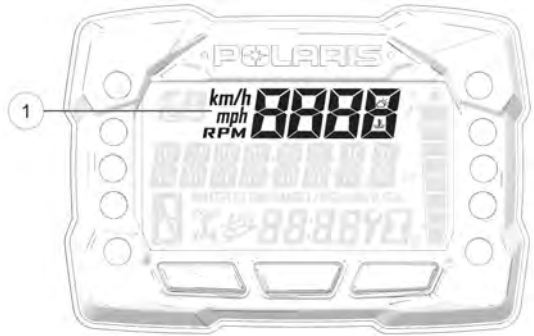

DISPLAY AREA 1	FUNCTION
Speed	The vehicle's speed will be displayed in mph, or km/h.
Engine Temperature	The vehicle's current engine temperature will be displayed.
RPM	The vehicle's RPM will be displayed.

FEATURES AND CONTROLS

DISPLAY AREA 2

Toggle the Up/Down buttons to change the information displayed in Area 2 ②.



DISPLAY AREA 2	FUNCTION
Odometer	The vehicle's odometer reading will be displayed.
Engine Temperature	The vehicle Engine Temperature will be displayed.
Trip 1	The vehicle Trip 1 mileage will be displayed.
Trip 2	The vehicle Trip 2 mileage will be displayed.
RPM	The vehicle RPM will be displayed.
Voltage	The vehicle's current battery voltage will be displayed.
Speed	The vehicle's current speed will be displayed.
Engine Hours	The vehicle's engine hours will be displayed.
Service Hours	The vehicle's service hours will be displayed.

OPTIONS MENU



Press and hold the MODE button to enter the Options Menu.

OPTIONS MENU	NOTES
Diagnostic Codes	Only displays if fault codes are present or stored
Units - Distance	Select MPH or KPH
Units - Temp	Select between °F and °C
Clock	Select between 12H or 24H, and set time
Backlight Color	Select between Blue or Red
Backlight Level	Set backlight brightness level
Service Hours	View/Set Service hours
Bluetooth® Pairing (if equipped)	Pair Bluetooth® device
Electronic Power Steering (EPS)	Set EPS mode at high, medium, or low
Exit Menu	Exit

FEATURES AND CONTROLS

DIAGNOSTIC CODE

Diagnostic Code Screen will show available MIL that has come on during that ignition cycle.

To access the Diagnostic Code Screen, do the following:

1. Press and hold the MODE button to enter the Options Menu. "OPTIONS" will display on the screen for 3 seconds before showing first menu item.
2. Select "Diagnostic Codes" from the Options Menu by pressing the MODE button.

Toggle the Up/Down Buttons to cycle through Code(s).

NOTICE

This option will only be available if a fault code was set or is active during the current ignition key 'on' cycle. Turning off the ignition will clear any save fault codes from the gauge.

- ① Display area 1 will show FMI
- ② Display area 2 will show SPN
- ③ Clock Area will show Count.

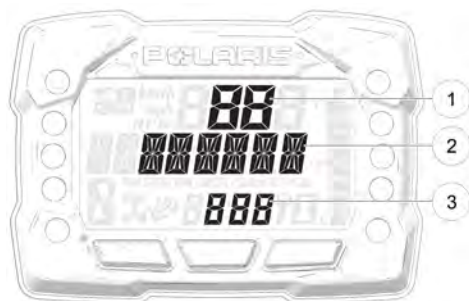

NOTICE

When the gauge is displaying a fault code, the warning telltale (check engine or EPS) will blink to indicate which controller set the fault code.

- To exit the Options Menu the user can select Exit Menu function from Options Menu, can hold Mode Button and exit out of Options Menu, or not press any button for 10 seconds, which will exit out of the Options Menu.

UNIT SELECTION DISTANCE

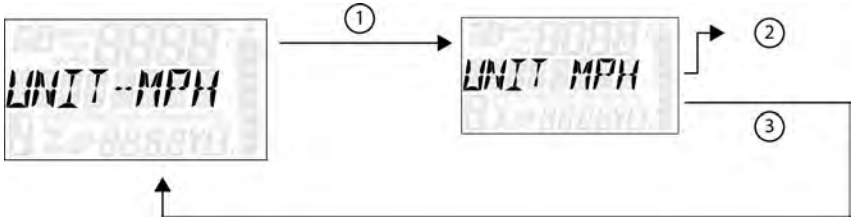

- Press and hold the MODE button to enter the Options Menu.

NOTICE

"OPTIONS" will display on the screen for 3 seconds before showing first menu item.

- Select "Units-Distance" from the Options Menu by pressing the MODE button.

Reference the image shown above:

- Press the MODE button.
 - Toggle the Up/Down Buttons to change the units (MPH or KPH)
 - With the correct unit displayed, Press the mode button which will set the unit and return to the Options Menu.
- To exit the Options Menu the user can select Exit Menu function from Options Menu, can hold Mode Button and exit out of Options Menu, or not press any button for 10 seconds, which will exit out of the Options Menu.

UNIT SELECTION TEMPERATURE

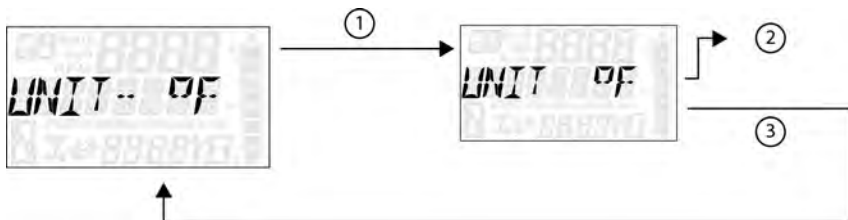

1. Press and hold the MODE button to enter the Options Menu.

NOTICE

"OPTIONS" will display on the screen for 3 seconds before showing first menu item.

2. Select "Units - Temp" from the Options Menu by pressing the MODE button.

Reference the image shown above:

- ① Press the MODE button.
 - ② Toggle the Up/Down Buttons to change the units (°F or °C)
 - ③ With the correct unit displayed, Press the mode button which will set the unit and return to the Options Menu.
3. To exit the Options Menu the user can select Exit Menu function from Options Menu, can hold Mode Button and exit out of Options Menu, or not press any button for 10 seconds, which will exit out of the Options Menu.

CLOCK (IF EQUIPPED)

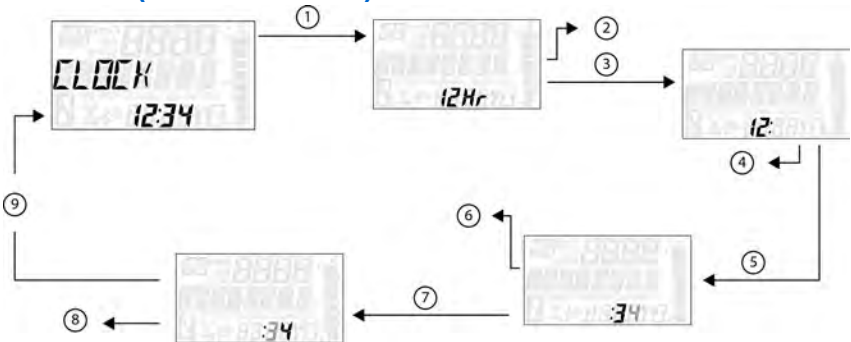

1. Press and hold the MODE button to enter the Options Menu.

NOTICE

"OPTIONS" will display on the screen for 3 seconds before showing first menu item.

2. Select "Clock" from the Options Menu by pressing the MODE button.

Reference the image shown above:

- ① Press the MODE button.
- ② Toggle the Up/Down Buttons to change the units (12H or 24H)
- ③ With the correct unit displayed, Press the mode button which will set the unit.
- ④ Toggle the Up/Down Buttons to change the units (Cycles Hours)
- ⑤ With the correct unit displayed, Press the mode button which will set the unit.
- ⑥ Toggle the Up/Down Buttons to change the units (Cycles 10s of Minutes)
- ⑦ With the correct unit displayed, Press the mode button which will set the unit.
- ⑧ Toggle the Up/Down Buttons to change the units (Cycles 1s of Minutes)
- ⑨ With the correct unit displayed. Press the mode button which will set the unit and return to the Options menu.

3. To exit the Options Menu the user can select Exit Menu function from Options Menu, can hold Mode Button and exit out of Options Menu, or not press any button for 10 seconds, which will exit out of the Options Menu.

BACK LIGHT COLOR

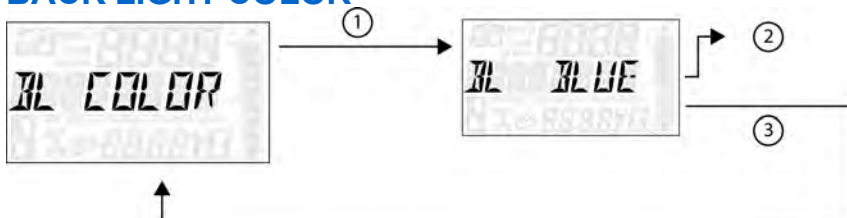

1. Press and hold the MODE button to enter the Options Menu.

NOTICE

"OPTIONS" will display on the screen for 3 seconds before showing first menu item.

2. Select "Backlight Color" from the Options Menu by pressing the MODE button.

Reference the image shown above:

- ① Press the MODE button.
 - ② Toggle the Up/Down Buttons to change the units (Blue or Red)
 - ③ With the correct unit displayed, Press the MODE button which will set the unit and return to the Options Menu.
3. To exit the Options Menu the user can select Exit Menu function from Options Menu, can hold MODE Button and exit out of Options Menu, or not press any button for 10 seconds, which will exit out of the Options Menu.

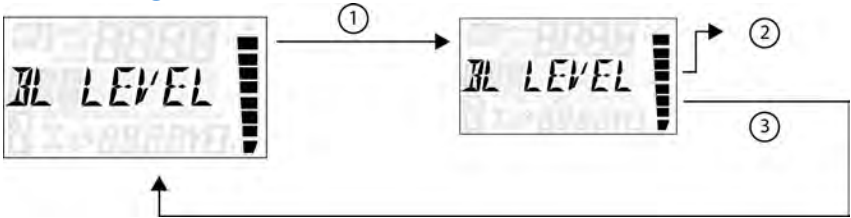
BACK LIGHT LEVEL

1. Press and hold the MODE button to enter the Options Menu.

NOTICE

"OPTIONS" will display on the screen for 3 seconds before showing first menu item.

2. Select "Backlight Level" from the Options Menu by pressing the MODE button.

Reference the image shown above:

- ① Press the MODE button.
 - ② Toggle the Up/Down Buttons to change the units (Increase or Decrease Level)
 - ③ With the correct unit displayed, Press the MODE button which will set the unit and return to the Options Menu.
3. To exit the Options Menu the user can select Exit Menu function from Options Menu, can hold MODE Button and exit out of Options Menu, or not press any button for 10 seconds, which will exit out of the Options Menu.

SERVICE HOURS

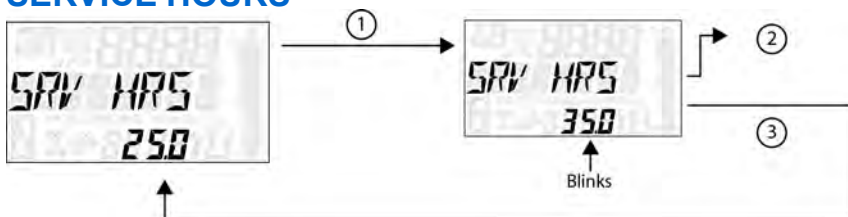

1. Press and hold the MODE button to enter the Options Menu.

NOTICE

"OPTIONS" will display on the screen for 3 seconds before showing first menu item.

2. Select "Service Hours" from the Options Menu by pressing the MODE button.

Reference the image shown above:

- ① Press the MODE button.
- ② Toggle the Up/Down Buttons to change the units (0, 5, 10 - 95, 100)
- ③ With the correct unit displayed, press the MODE button, which will set the unit and return you to the Options Menu.

NOTICE

To reset service hours after they have counted down to "0.0", reselect the existing setpoint or select a new service hour value.

3. To exit the Options Menu the user can select Exit Menu function from Options Menu, can hold MODE Button and exit out of Options Menu, or not press any button for 10 seconds, which will exit out of the Options Menu.

BLUETOOTH® (IF EQUIPPED)

The Bluetooth® functionality allows users to pair their phones with the vehicle's digital gauge. This function allows users to receive call and text alerts while operating the vehicle.

If a text message is received while the vehicle is moving faster than 2 KPH, only the sender's name is shown onscreen.



If you are browsing any of the Bluetooth® menus and the vehicle starts to move faster than 2 KPH, the menu will automatically display *VEHICLE MOVING*. If you attempt to access Bluetooth® menus while the vehicle is moving faster than 2 KPH, the screen will display *VEHICLE MOVING* momentarily, and then it will redirect to the options menu.

PAIRING YOUR PHONE TO THE GAUGE

Use the following procedure to pair your phone with the vehicle's digital gauge.

NOTICE

Bluetooth® functionality is compatible with both iOS® and Android® phones. For iOS® phones, you must go to the Settings option and enable notifications. Most Android® phones will prompt the user automatically to enable notifications as part of the pairing process.

1. Make sure Bluetooth® is enabled on your phone.
2. Access the options menu on the vehicle's digital gauge and select *BT PAIR*. The Bluetooth® icon will begin to blink.
3. Find and select *Polaris Gauge* on your phone's Bluetooth® menu or prompt. Pairing should occur momentarily. Pairing mode will continue for up to 90 seconds or if you exit the *BT PAIR* menu.

After successfully pairing the phone, the vehicle's digital gauge will automatically reconnect with the phone each time it is powered on and within range. No further action is required by the user at this point.

OPERATION

IMPORTANT INFORMATION

 **WARNING**

Failure to operate the vehicle properly can result in a collision, loss of control, accident or rollover, which may result in serious injury or death. Read and understand all safety warnings outlined in the safety section of this owner's manual.

SAFE OPERATION PRACTICES

 **WARNING**

Failure to operate the vehicle properly can result in a collision, loss of control, accident or rollover, which may result in serious injury or death. Read and understand all safety warnings outlined in the safety section of this owner's manual.

1. Complete the recommended safety training before operating this vehicle. Visit www.atvsafety.org for safety courses and riding tips. See page 11 for details.
2. Do not allow anyone under 16 years of age to operate this vehicle. Do not allow anyone with cognitive or physical disabilities to operate this vehicle.
3. Never carry a passenger on a 1-up ATV. Never carry more than one passenger on a 2-up ATV.
4. Engine exhaust fumes are poisonous. Never start the engine or let it run in an enclosed area.
5. Before operating, learn how to use the auxiliary brake for emergency situations (if service brakes become inoperable).
6. Use caution and drive at reduced speeds in conditions of reduced visibility such as fog, rain and darkness. Clean headlights frequently and replace burned out headlamps promptly.
7. Drive in a manner appropriate for your skills, your passenger's skills (if you are operating a 2-up ATV), and operating conditions. Never operate at excessive speeds. Never attempt wheelies, jumps, or other stunts. Never remove your hands from the handlebars while operating, and always keep both feet on the footrests.
8. Never consume alcohol or drugs before or while operating an ATV.
9. Always use the size and type of tires specified for your vehicle. Always maintain proper tire pressure.

OPERATION

10. Never operate a damaged ATV. After any overturn or accident, have a qualified service dealer inspect the entire machine for possible damage.
11. Never operate the ATV on a frozen body of water unless you have independently verified that the ice is sufficiently thick to support the weight and moving force of the ATV, you and your cargo, together with any other vehicles in your party.
12. Do not touch hot exhaust system components. Always keep combustible materials away from the exhaust system.
13. Always remove the ignition key when the vehicle is not in use to prevent unauthorized use.

TRAIL ETIQUETTE

Always practice good etiquette when riding. Allow a safe distance between your vehicle and other vehicles operating in the same area. Communicate to oncoming operators by signaling the number of vehicles in your group. When stopping, move your vehicle to the edge of the trail as far as possible to allow others to pass safely.

KNOW YOUR RIDING AREA/TREAD LIGHTLYSM

Familiarize yourself with all laws and regulations concerning the operation of this vehicle in your area. Respect the environment in which you ride your vehicle. Find out where the designated riding areas are by contacting your POLARIS dealer, a local riding club, or local officials.

Help keep our trails open for recreational vehicle use. As an off-road enthusiast, you represent the sport and can set a good example (or a poor example) for others to follow. Tread LightlySM. Operate with respect for the terrain, avoid littering, and always stay on the designated trails.

VEHICLE BREAK-IN PERIOD

The break-in period for your new POLARIS vehicle is the first 25 hours of operation, or the time it takes to use the first two tanks full of gasoline. No single action on your part is as important as a proper break-in period. Careful treatment of a new engine and drive components will result in more efficient performance and longer life for these components. Perform the following procedures carefully.

NOTICE

Excessive heat build-up during the first three hours of operation will damage close-fitted engine parts and drive components. Do not operate at full throttle or high speeds during the first three hours of use.

Use of any improper oils may cause serious engine damage. POLARIS PS-4 Full Synthetic 5W-50 4-Cycle Oil is specifically formulated for your 4-cycle engine.

ENGINE AND DRIVETRAIN BREAK-IN

1. Fill the fuel tank with gasoline. Always exercise extreme caution whenever handling gasoline.
2. Check the oil level. See the Oil Level Check section for reference. Add the recommended oil as needed to maintain the oil level in the safe operating range.
3. Drive slowly at first. Select an open area that allows room to familiarize yourself with vehicle operation and handling.
4. Avoid aggressive use of the brakes.
5. Vary throttle positions. Do not operate at sustained idle.
6. Pull only light loads.
7. Perform regular checks on fluid levels, controls, and areas outlined in the pre-ride inspection checklist.
8. During the break-in period, change both the engine oil and filter at 25 hours.
9. During the break-in period, check fluid levels of transmission and all gearcases at 25 hours or 250 miles (400 km) (whichever comes first).

OPERATION

BRAKE SYSTEM BREAK-IN

Apply only moderate braking force for the first 50 stops. Aggressive or overly forceful braking when the brake system is new could damage brake pads and rotors.

Perform the following steps on a new vehicle or anytime brake pads are replaced on the vehicle:

1. In an appropriate riding area, safely slow the vehicle with moderate (70%) braking from 30 mph (50 km/h) down to 5 mph (8 km/h). Do not stop completely in order to keep air flowing through the brakes.
2. Repeat for 10-20 cycles and let the brakes cool between each cycle by riding your vehicle approximately 0.25 miles (400 m).
3. After you have completed all 20 cycles, ride the ATV for awhile to cool the braking system to avoid overheating the brakes.
4. Stop the vehicle and put the transmission in PARK. DO NOT apply the parking brake until the brake system has fully cooled.

PVT BREAK-IN (CLUTCHES/BELT)

Always break in the clutches and drive belt of new vehicles, as well as after a belt replacement.

A proper break-in of the clutches and drive belt will ensure a longer life and better performance. Break in the clutches and belt by operating at slower speeds during the break-in period as recommended. Pull only light loads. Avoid aggressive acceleration and high speed operation during the break-in period.

If a belt fails and you need to replace it, always clean all debris from the PVT intake and outlet duct, the clutch, and the engine components.

PRE-RIDE CHECKLIST

Failure to inspect and verify that the ATV is in safe operating condition before operating increases the risk of an accident. Always inspect the ATV before each use to make sure it's in safe operating condition.

ITEM	REMARKS	PAGE
Brake system/lever travel	Ensure proper operation	page 33 page 104
Brake fluid	Ensure proper level	page 35 page 36
Auxiliary brake	Ensure proper operation	page 36
Front suspension	Inspect	-
Rear suspension	Inspect	-
Steering	Ensure free operation	-
Tires	Inspect condition and pressure	page 106
Wheels/fasteners	Inspect, ensure fastener tightness	page 107
Fuel and oil	Ensure proper levels	page 95
Coolant level	Ensure proper level	page 103
Coolant hoses	Inspect for leaks	-
Throttle	Ensure proper operation	page 31
Indicator lights/switches	Ensure operation	page 44
Engine stop switch	Ensure proper operation	page 30
Air filter, pre-filter	Inspect, clean	page 109
Headlamp	Check operation	page 30
Brake light/taillight	Check operation	-
Riding gear	Wear approved helmet, goggles, and protective clothing	page 11
Winch (if equipped)	Inspect cable and switch	page 77
Grass and Leaves	Remove grass, leaves, foreign matter, and other flammable material or debris, especially near the exhaust system	-

OPERATION

NEW OPERATOR DRIVING PROCEDURES

1. Complete a certified safety training course. See the Safety Training section.
2. Wear protective riding gear. See the Safe Riding Gear section.
3. Perform the pre-ride inspection.
4. Place the transmission in PARK.
5. Lock the parking brake.
6. Mount the vehicle from the left side.
7. Sit upright with both feet on the footrests and both hands on the handlebars.
8. Start the engine and allow it to warm up.
9. Shift the transmission into gear.
10. Check your surroundings and determine your path of travel.
11. Release the parking brake.
12. Slowly depress the throttle with your right thumb and begin driving.
13. Drive slowly. Practice maneuvering and using the throttle and brakes on level surfaces.

TURNING THE VEHICLE

Both rear wheels drive equally at all times. This means that the outside wheel must travel a greater distance than the inside wheel when turning, and the inside tire must slip traction slightly.

1. Slow down.
2. Never turn quickly when carrying cargo.
3. Steer in the direction of the turn.
4. Keep both feet on the footrests.
5. Lean your upper body to the inside of the turn while supporting your weight on the outer footrest. This technique alters the balance of traction between the rear wheels, allowing the turn to be made smoothly. The same leaning technique should be used for turning in reverse.
6. Practice making turns at slow speeds before attempting to turn at faster speeds.

WARNING

Turning improperly can result in vehicle overturn. Never turn abruptly or at sharp angles. Never turn at high speeds.

DRIVING ON SLIPPERY SURFACES

Whenever riding on slippery surfaces such as wet trails or loose gravel, or during freezing weather, follow these precautions:

1. Do not operate on excessively rough, slippery or loose terrain.
2. Slow down when entering slippery areas.
3. Engage AWD before wheels begin to lose traction.

NOTICE
Severe damage to drive train may occur if the AWD is engaged while the wheels are spinning. Allow the rear wheels to stop spinning before engaging AWD, or engage AWD before wheels begin to lose traction.

4. Maintain a high level of alertness, reading the trail and avoiding quick, sharp turns, which can cause skids.
5. Never apply the brakes during a skid. Correct a skid by turning the handlebars in the direction of the skid and shifting your body weight forward.

OPERATION

DRIVING UPHILL

Braking and handling are greatly affected when operating in hilly terrain. Improper procedure could cause loss of control or overturn. Whenever traveling uphill, follow these precautions:

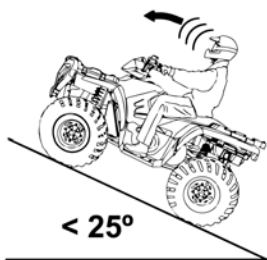

1. Always engage AWD before ascending or descending a hill.
2. Drive straight uphill.
3. Avoid steep hills. Maximum incline is 25°.
4. Always check the terrain carefully before ascending any hill.
5. Never climb hills with excessively slippery or loose surfaces.
6. Keep both feet on the footrests.
7. Shift body weight uphill.
8. Proceed at a steady rate of speed and throttle opening. Opening the throttle suddenly could cause the ATV to flip over backwards.
9. Never go over the top of any hill at high speed. An obstacle, a sharp drop, or another vehicle or person could be on the other side of the hill.
10. Remain alert and be prepared to take emergency action. This may include quick dismounting of the vehicle.

DRIVING DOWNHILL



When driving downhill, follow these precautions:

1. Always check the terrain carefully before descending a hill.
2. Always engage AWD before ascending or descending a hill.
3. Avoid steep hills. Maximum incline is 25°.
4. Always descend a hill with the transmission in forward gear. Do not descend a hill with the transmission in neutral.
5. Slow down. Never travel down a hill at high speed.
6. Drive straight downhill. Avoid traveling down a hill at an angle, which would cause the vehicle to lean sharply to one side.
7. Shift body weight uphill.
8. Apply the brakes *slightly* to aid in slowing. Applying the brakes too firmly may cause the rear wheels to lock, which could result in loss of control.

OPERATION

DRIVING ON A SIDEHILL (SIDEHILLING)

Driving on a sidehill is not recommended. Improper procedure could cause loss of control or overturn. Avoid crossing the side of any hill unless absolutely necessary.



If crossing a sidehill is *unavoidable*, follow these precautions:

1. Slow down.
2. Avoid crossing the side of a steep hill.
3. Lean into the hill, transferring your upper body weight toward the hill while keeping your feet on the footrests.
4. If the vehicle begins to tip, quickly turn the front wheel downhill, if possible, or dismount on the uphill side *immediately!*

TURNING AROUND ON A HILL (K-TURN)

If the vehicle stalls while climbing a hill, never back it down the hill! Use the K-turn to turn around.

1. Stop and lock the parking brake while keeping body weight uphill.
2. Always engage AWD before ascending or descending a hill.
3. Leave the transmission in forward and shut off the engine.
4. Dismount on the uphill side of the vehicle, or on the left if the vehicle is pointing straight uphill.
5. Staying uphill of the vehicle, turn the handlebars full left.
6. While holding the brake lever, release the parking brake lock and slowly allow the vehicle to roll around to your right until it's pointing across the hill or slightly downward.
7. Lock the parking brake. Remount the vehicle from the uphill side, keeping body weight uphill. Start the engine with the transmission still in forward.
8. Release the parking brake and proceed *slowly*, controlling speed with the brake lever, until the vehicle is on more level ground.

DRIVING THROUGH WATER



Your ATV can operate through water with a maximum recommended depth equal to the bottom of the footrests. Follow these procedures when operating through water:

1. Determine water depths and current before entering water.
2. Choose a crossing where both banks have gradual inclines.
3. Avoid operating through deep or fast-flowing water.

NOTICE

Major engine damage can result if the vehicle is not thoroughly inspected after operation in water. Perform the services outlined in the Periodic Maintenance Chart. The following areas need special attention: engine oil, transmission oil, demand drive fluid and all grease fittings.

If the vehicle tips or overturns in water, or if the engine stops during or after operating in water, service is required before starting the engine. Your POLARIS dealer can provide this service. If it's impossible to bring the vehicle in before starting the engine, perform the service outlined in the Vehicle Immersion section of this manual, and take the vehicle in for service at the first opportunity.

4. After leaving water, test the brakes. Apply them lightly several times while driving slowly. The friction will help dry out the pads.

If it's unavoidable to enter water deeper than the footrest level:

- Proceed slowly. Avoid rocks and obstacles.
- Balance your weight carefully. Avoid sudden movements.
- Maintain a steady rate of speed. Do not make sudden turns or stops. Do not make sudden throttle changes.

OPERATION

DRIVING OVER OBSTACLES

Follow these precautions when operating over obstacles:



1. Always check for obstacles before operating in a new area.
2. Look ahead and learn to read the terrain. Be constantly alert for hazards such as logs, rocks and low hanging branches.
3. Travel slowly and use extra caution when operating on unfamiliar terrain. Not all obstacles are immediately visible.
4. Never attempt to operate over large obstacles, such as rocks or fallen trees.
5. If you are operating a 2-up ATV, always have the passenger dismount before you operate over an obstacle that could cause a fall from the vehicle or vehicle tipover.

DRIVING IN REVERSE

Follow these precautions when operating in reverse:



1. Always check for obstacles or people behind the vehicle.
2. Always avoid backing downhill.
3. Back slowly.
4. Apply the brakes *lightly* for stopping.
5. Avoid turning at sharp angles.
6. Never open the throttle suddenly.
7. Do not use the override switch unless additional wheel speed is required for vehicle movement. Use the override with caution as rearward vehicle speed is greatly increased. Do not operate at wide open throttle. Operate the throttle just enough to maintain a desired speed.

NOTICE

Excessive throttle operation while in the speed limit mode may cause fuel to build in the exhaust, resulting in engine popping and/or engine damage.

OPERATION

STARTING THE ENGINE

1. Position the vehicle on a level surface outdoors or in a well-ventilated area.
2. Place the transmission in PARK.
3. Lock the parking brake.

TIP

The starter interlock will prevent the engine from starting if the brake is not engaged.

4. Sit on the vehicle and move the engine stop switch to RUN.

TIP

Do not press the throttle while starting the engine.

5. Turn the ignition key past the ON position to engage the starter. Activate the starter for a maximum of five seconds, releasing the key when the engine starts.
6. If the engine does not start, return the key to the OFF position and wait five seconds before attempting to start again. Activate the starter for another five seconds if necessary. Repeat this procedure until the engine starts.

NOTICE

Operating the vehicle immediately after starting could cause engine damage. Allow the engine to warm up for several minutes before operating the vehicle.

COLD WEATHER OPERATION

If the vehicle is used year-round, check the oil level frequently. A rising oil level could indicate the accumulation of contaminants such as water or excess fuel in the bottom of the crankcase. Water in the bottom of the crankcase can lead to engine damage and must be drained. Water accumulation increases as outside temperature decreases.

STOPPING THE ENGINE

1. Release the throttle completely and brake to a complete stop.
2. Place the transmission in PARK.
3. Turn the key to the OFF position.
4. Slowly release the brake pedal and make sure the transmission is in PARK before exiting the vehicle.



A rolling vehicle can cause serious injury. Always place the transmission in PARK before stopping the engine.

FUEL RECOMMENDATION

Polaris recommends using fresh Unleaded 87 Octane TOP TIER DETERGENT GASOLINE® containing up to 10% ethanol purchased during the season of vehicle usage. This fuel will provide the best engine performance (starting, run quality, fuel economy, and power) and durability.

Octane Rating

Polaris recommends a minimum of 87 Octane (R+M/2) rated gasoline. Using lower octane gasoline could result in engine damage.

Ethanol Content

Polaris recommends gasoline containing up to 10% ethanol (E10). Higher levels of ethanol (ex. E15 and E85) may result in engine damage.

Detergent Gasoline

Polaris recommends TOP TIER DETERGENT GASOLINE® to keep the engine cleaner by reducing carbon deposits, which will help maintain engine performance and durability. Refer to www.toptiergas.com for a list of TOP TIER DETERGENT GASOLINE® retailers. Alternatively, the logo shown below on the retailer's fuel pump will confirm that TOP TIER DETERGENT GASOLINE® is being dispensed.



If TOP TIER DETERGENT GASOLINE® is not available, adding Polaris Carbon Clean to the fuel tank at every oil change will help reduce carbon deposits.

Seasonal Blends

Polaris recommends using gasoline that is purchased during the season the vehicle is being used, especially summer vs. winter. Between seasons, refineries typically change the gasoline blend to avoid temperature induced engine performance issues. Winter blend gasoline improves engine starting in cold weather and summer blend gasoline helps prevent vapor lock issues in hot weather.

OPERATION

PARKING THE VEHICLE

1. Stop the vehicle on a level surface. When parking inside a garage or other structure, be sure that the structure is well ventilated and that the vehicle is not close to any source of flame or sparks, including any appliance with pilot lights.
2. Place the transmission in PARK.
3. Turn the engine off.
4. Engage the parking brake (if equipped).
5. Slowly release the brake pedal and make sure the transmission is in PARK before exiting the vehicle.
6. Remove the ignition key to prevent unauthorized use.

PARKING ON AN INCLINE

Avoid parking on an incline if possible. If it's unavoidable, follow these precautions:

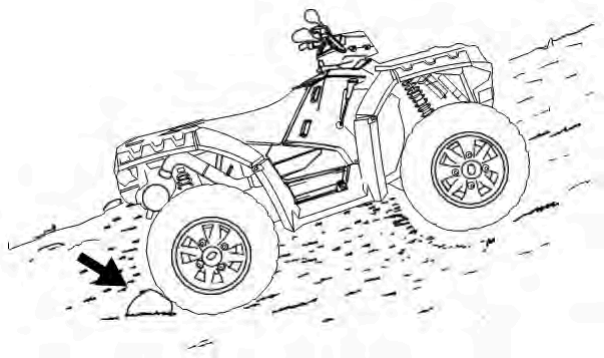

1. Stop the engine.
2. Place the transmission in PARK.
3. Lock the parking brake.
4. Always block the rear wheels on the downhill side.

HAULING CARGO

CARGO WARNING

WARNING

Overloading the vehicle or carrying or towing cargo improperly can alter vehicle handling and may cause loss of control or brake instability, which can result in serious injury or death. Always follow these precautions when hauling cargo:

REDUCE SPEED AND ALLOW GREATER DISTANCES FOR BRAKING WHEN HAULING CARGO.

NEVER EXCEED THE MAXIMUM WEIGHT CAPACITY of the vehicle. When determining the weight you are adding to the vehicle, include the weight of the operator, passenger (if you are operating a 2-up ATV), accessories, loads in the rack or box and the load on the trailer tongue. The combined weight of these items must not exceed the maximum weight capacity.

CARGO WEIGHT DISTRIBUTION should be 1/3 on the front rack and 2/3 on the rear rack. When operating over rough or hilly terrain, reduce speed and cargo to maintain stable driving conditions. Carrying loads on only one rack increases the possibility of vehicle overturn.

CARRY LOADS AS LOW ON THE RACKS AS POSSIBLE. Carrying loads high on the racks raises the center of gravity of the vehicle and creates a less stable operating condition.

SECURE ALL LOADS BEFORE OPERATING. Unsecured loads can create unstable operating conditions, which could result in loss of control of the vehicle.

WARNING

OPERATE ONLY WITH STABLE AND SAFELY ARRANGED LOADS. When handling off-centered loads that cannot be centered, securely fasten the load and operate with extra caution. Always attach the tow load to the hitch point designated for your vehicle.

HEAVY LOADS CAN CAUSE BRAKING AND CONTROL PROBLEMS. Use extreme caution when applying brakes with a loaded vehicle. Avoid terrain or situations that may require backing downhill.

USE EXTREME CAUTION when operating with loads that extend over the rack sides. Stability and maneuverability may be adversely affected, causing the vehicle to overturn.

DO NOT BLOCK THE FRONT HEADLIGHT BEAM when carrying loads on the front rack.

DO NOT TRAVEL FASTER THAN THE RECOMMENDED SPEEDS.

The vehicle should never exceed 10 mph (16 km/h) while towing a load on a level surface. Vehicle speed should never exceed 5 mph (8 km/h) when towing loads in rough terrain, while cornering, or while ascending or descending a hill.

HAULING CARGO GUIDELINES

When hauling cargo, adhere to the following:

1. Never exceed the weight capacities specified for your ATV on warning labels and in the specifications section of this manual.
2. Cargo weight should be evenly distributed (1/3 on the front rack and 2/3 on the rear rack) and mounted as low as possible.
3. When operating over rough or hilly terrain, reduce speed and cargo weight to maintain stable driving conditions.
4. Do not obstruct the headlight beam with cargo.
5. Slow down.
6. Use low forward gear when hauling or towing heavy cargo to extend belt life.
7. Always operate the vehicle with extreme caution whenever hauling or towing loads. Balance, handling and control may be affected.

TOWING LOADS

IMPORTANT

Towing a trailer with a POLARIS Scrambler is not recommended. If towing a trailer, ensure the receiver does not exceed a two inch drop or raise.

Always attach a towed load to the hitch point. Remove the hitch from the ATV when not towing a trailer. If towing a load, reduce rear rack cargo weight by the amount of tongue weight.

- The combination of rear rack cargo weight and tongue weight must not exceed the rear rack capacity.
- The total load (operator, accessories, cargo and weight on hitch) must not exceed the maximum weight capacity of the vehicle.

NOTICE

Using an improper hitch or exceeding the maximum tongue weight capacity can result in serious damage to the vehicle. Never install a hitch longer than 4" (10 cm). Never install automotive accessories on your POLARIS ATV. Always install POLARIS-approved (or equivalent) accessories designed for ATV use.

MAXIMUM TOWING CAPACITIES

Do not exceed maximum towing capacities. Avoid towing on inclines.

Maximum Towed Load (Level Ground)	1500 lbs. (680 kg)
Maximum Vertical Hitch Weight	150 lbs. (68 kg)

WINCH GUIDE (IF EQUIPPED)

WINCH SAFETY

These safety warnings and instructions apply if your vehicle came equipped with a winch or if you choose to add an accessory winch to your vehicle.

 **WARNING**

Improper winch use can result in **SEVERE INJURY** or **DEATH**. Always follow all winch instructions and warnings in this manual.

Your winch may have a cable made of either wire rope or specially designed synthetic rope. The term “winch cable” will be used for either unless noted otherwise.

WINCH SAFETY PRECAUTIONS

1. Read all sections of this manual.
2. Never use alcohol or drugs before or while operating the winch.
3. Never allow children under 16 years of age to operate the winch.
4. Always wear eye protection and heavy gloves when operating the winch.
5. Always keep body, hair, clothing and jewelry clear of the winch cable, fairlead and hook when operating winch.
6. Never attempt to “jerk” a load attached to the winch with a moving vehicle. See the *Shock Loading* section on page 85.
7. Always keep the area around the vehicle, winch, winch cable, and load clear of people (especially children) and distractions while operating the winch.
8. Always turn the vehicle ignition power OFF when it and the winch are not being used.
9. Always be sure that at least five (5) full turns of winch cable are wrapped around the winch drum at all times. The friction provided by this wrapped cable allows the drum to pull on the winch cable and move the load.
10. Always apply your vehicle’s park brake and/or park mechanism to hold the vehicle in place during winching. Use wheel chocks if needed.
11. Always align the vehicle and winch with the load directly in front of the vehicle as much as possible. Avoid winching with the winch cable at an angle to the winching vehicle’s centerline whenever possible.

WINCH GUIDE (IF EQUIPPED)

12. If winching at an angle is unavoidable, follow these precautions:
 - a. Look at the winch drum occasionally. Never let the winch cable “stack” or accumulate at one end of the winch drum. Too much winch cable at one end of the winch drum can damage the winch and the winch cable.
 - b. If stacking occurs, stop winching. Follow step 15 of Winch Operation to feed and rewind the cable evenly before continuing the winch operation.
13. Never winch up or down at sharp angles. This can destabilize the winching vehicle and possibly cause it to move without warning.
14. Never attempt to winch loads that weigh more than the winch’s rated capacity.
15. The winch motor may become hot during winch use. If you winch for more than 45 seconds, or if the winch stalls during operation, stop winching and permit the winch to cool down for 10 minutes before using it again.
16. Never touch, push, pull or straddle the winch cable while winching a load.
17. Never let the winch cable run through your hands, even if wearing heavy gloves.
18. Never release the clutch on the winch when the winch cable is under load.
19. Never use the winch for lifting or transporting people.
20. Never use the winch to hoist or suspend a vertical load.
21. Always inspect your winch and winch cable before each use.
22. Never winch the hook fully into the winch. This can cause damage to winch components.
23. Unplug the remote control from the vehicle when the winch is not in use to prevent inadvertent activation and use by unauthorized persons.
24. Never grease or oil the winch cable. This will cause the winch cable to collect debris that will shorten the life of the cable.



WINCH OPERATION

Read the Winch Safety Precautions in the preceding pages before using your winch.

TIP

Consider practicing the operation and use of your winch before you actually need to use it in the field.

⚠ WARNING

Improper winch use can result in **SEVERE INJURY** or **DEATH**. Always follow all winch instructions and warnings in this manual.

Each winching situation is unique.

- Take your time to think through the winching you are about to do.
- Proceed slowly and deliberately.
- Never hurry or rush during winching.
- Always pay attention to your surroundings.
- You may need to change your winching strategy if it is not working.
- Always remember that your winch is very powerful.
- There are simply some situations that you and your winch will not be able to deal with. Do not be afraid to ask others to help when this happens.

1. Always inspect the vehicle, winch, winch cable and winch controls for any signs of damage or parts in need of repair or replacement before each use. *Pay particular attention to the first 3 feet (1 meter) of winch cable if the winch is being used (or has been used) for lifting an accessory plow assembly.* Promptly replace any worn or damaged cable.
2. Never operate a winch or a vehicle in need of repair or service.
3. Always apply your vehicle's park brake and/ or park mechanism to hold the vehicle in place during winching. Use wheel chocks if needed.
4. Always use the hook strap when handling the hook.



WINCH GUIDE (IF EQUIPPED)

WARNING

Never put your fingers into the hook. This could lead to SEVERE INJURY.

- Attach the hook itself onto the load or use a tow strap or chain to secure the load to the winch cable.



TIP

A “tow strap” is NOT intended to stretch. A “recovery strap” is designed to stretch.

WARNING

Never use a recovery strap when winching due to the excessive energy that can be released if the winch cable breaks. This can result in SEVERE INJURY or DEATH. See the *Shock Loading* section on page 85.

- Never hook the winch cable back onto itself. This will damage the winch cable and may result in winch cable failure.

WARNING

Replace the winch cable at the first sign of damage to prevent SEVERE INJURY or DEATH in the event of failure. For your safety, always replace POLARIS winch parts (including the cable) with genuine POLARIS replacement parts available at your authorized POLARIS dealer, or other qualified dealer.

WINCH GUIDE (IF EQUIPPED)

- If possible, keep the winch cable aligned with the centerline of the winching vehicle. This will help the spooling of the winch cable and reduce the load on the fairlead.
- If freeing a stuck vehicle by attaching to a tree, use an item such as a tow strap to avoid damaging the tree during winch operation. Sharp cables and chains can damage and even kill trees. Please remember to Tread LightlySM (treadlightly.org).
- Before operating the winch, be sure that the safety latch on the winch cable hook is fully seated when the load is attached.
- Never operate your winch with a damaged hook or latch. Always replace damaged parts before using the winch.

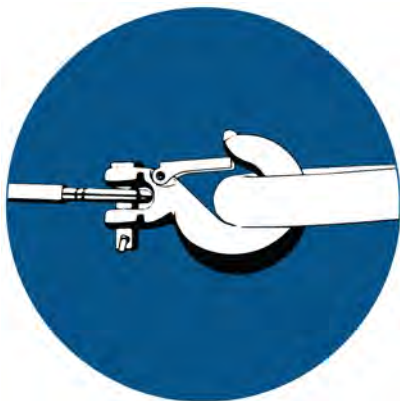

5. Never remove the hook strap from the hook.
6. Release the winch clutch and pull out the winch cable.
7. Pulling out as much cable as possible maximizes the winch's pulling capacity. Always be sure that at least five (5) full turns of winch cable are wrapped around the winch drum at all times. The friction provided by this wrapped cable allows the drum to pull on the winch cable and move the load.
8. Read and adhere to the following information for winch damping to ensure safe winch use.
 - a. In order to absorb energy that could be released by a winch cable failure, always place a "damper" on the winch cable. A damper can be heavy jacket, tarp, or other soft, dense object. A damper can absorb much of the energy released if a winch cable breaks when winching. Even a tree limb can help as a damper if no other items are available to you.
 - b. Lay the damper on top of the mid-point of the winch cable length that is spooled out.

WINCH GUIDE (IF EQUIPPED)

- c. On a long pull, it may be necessary to stop winching so that the damper can be repositioned to the new mid-point of the winch cable. Always release the tension on the winch cable before repositioning the damper.
 - d. Avoid being directly in line with the winch cable whenever possible. Also, never permit others to stand near or in line with the winch cable during winch operation.
9. Never hook the winch cable back onto itself. This will damage the winch cable and may result in winch cable failure.
10. Never use straps, chains or other rigging items that are damaged or worn.
11. The ONLY time a winch-equipped vehicle should be moving when using the winch is when that vehicle itself is stuck. The winch equipped vehicle should NEVER be in motion to “shock” load the winch cable in an attempt to move a second stuck vehicle. See the Shock Loading section on page 85. For your safety, always follow these guidelines when winching a vehicle free:
- a. Release the winch clutch and spool out the necessary length of winch cable.
 - b. Align the winch cable as close as possible to the winching vehicle's centerline.
 - c. Attach the winch cable hook to the anchor point or the stuck vehicle's frame following instructions in this manual.
 - d. Re-engage the clutch on the winch.
 - e. Slowly winch in the slack in the winch cable.
 - f. Select the proper vehicle gear to propel the stuck vehicle in the direction of winching.
 - g. Shift to the lowest gear available on the stuck vehicle.
 - h. Slowly and carefully apply vehicle throttle and winch together to free the vehicle.
 - i. Stop winching as soon as the stuck vehicle is able to propel itself without the help of the winch.
 - j. Detach the winch cable hook.
 - k. Rewind the winch cable evenly back onto the winch drum following the instructions in this manual.
12. Never attempt to winch another stuck vehicle by attaching the winch cable to a suspension component, brush guard, bumper or cargo rack. Vehicle damage may result. Instead, attach the winch to a strong portion of the vehicle frame or hitch.

WINCH GUIDE (IF EQUIPPED)

13. Extensive winching will run down the battery on the winching vehicle. Let the winching vehicle's engine run while operating the winch to prevent the battery from running low if winching for long periods.
14. The winch motor may become hot during winch use. If you winch for more than 45 seconds, or if the winch stalls during operation, stop winching and permit the winch to cool down for 10 minutes before using it again.
15. After winching is complete, especially if winching at an angle, it may be necessary to re-distribute the winch cable across the winch drum. You will need an assistant to perform this task.
 - a. Release the clutch on the winch.
 - b. Feed out the winch cable that is unevenly bunched up in one area.
 - c. Re-engage the winch clutch.
 - d. Have an assistant pull the winch cable tightly with about 100 lbs. (45 kg) of tension using the hook strap.
 - e. Slowly winch the cable in while your assistant moves the end of the winch cable back and forth horizontally to evenly distribute the winch cable on the drum.
 - f. Doing this reduces the chances of the winch cable "wedging" itself between lower layers of winch cable.

WINCH GUIDE (IF EQUIPPED)

WINCH CABLE CARE

WARNING

Use of worn or damaged cable could lead to sudden failure and SEVERE INJURY.

For your safety, always replace POLARIS winch parts (including the cable) with genuine POLARIS replacement parts available at your authorized POLARIS dealer, or other qualified person.

1. Always inspect your winch before each use. Inspect for worn or loose parts including mounting hardware. Never use the winch if any part needs repair or replacement.
2. Always inspect your winch cable before each use. Inspect for worn or kinked winch cable.

A kinked winch cable made of wire rope is shown at right. Even after being “straightened out,” this cable has already been permanently and severely damaged. Promptly discontinue use of a winch cable in this condition.

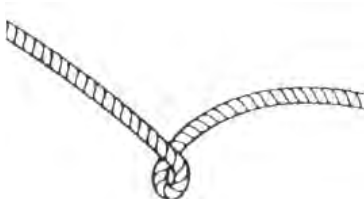

A kinked winch cable made of wire rope that has been “straightened out” is shown at right. Even though it may look usable, the cable has been permanently and severely damaged. It can no longer transmit the load that it could prior to kinking. Promptly discontinue use of a winch cable in this condition.

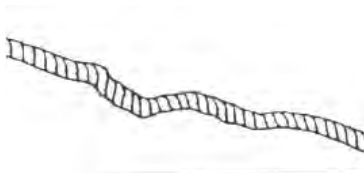

A winch cable made of synthetic rope should be inspected for signs of fraying. Replace the cable if fraying is observed (shown below). Promptly discontinue use of a winch cable in this condition. Also replace the winch cable if there are fused or melted fibers. Such an area of the synthetic rope will be stiff and appear smooth or glazed. Promptly discontinue use of a winch cable in this condition.



SHOCK LOADING

WARNING

Your winch cable is very strong but it is NOT designed for dynamic, or “shock” loading. Shock loading may tension a winch cable beyond its strength and cause the cable to break. The end of a broken winch cable under such high loading can cause SEVERE INJURY or DEATH to you and other bystanders.

Winch cables are designed to NOT absorb energy. This is true of both wire-rope and synthetic-rope winch cables.

1. Never attempt to “jerk” a load with the winch. For example, never take up slack in the winch cable by moving the winching vehicle in an attempt to move an object. This is a dangerous practice. It generates high winch cable loads that may exceed the strength of the cable. Even a slowly moving vehicle can create large shock loads in a winch cable.

WARNING

SEVERE INJURY or DEATH can result from a broken winch cable.

2. Never quickly turn the winch ON and OFF repeatedly (“jogging”). This puts extra load on the winch, winch cable, and generates excessive heat from the motor. This is a form of shock loading.
3. Never tow a vehicle or other object with your winch. Towing an object with a winch produces shock loading of the cable even when towing at slow speeds. Towing from a winch also positions the towing force high on the vehicle. This can cause instability of the vehicle and possibly lead to an accident.
4. Never use recovery straps with your winch. Recovery straps are designed to stretch and can store energy. This stored energy in the recovery strap is released if a winch cable fails making the event even more hazardous. Similarly, never use elastic “bungee” cords for winching.
5. Never use the winch to tie down a vehicle to a trailer or other transportation vehicle. This type of use also causes shock loading that can cause damage to the winch, winch cable, or vehicles used.

Your winch cable is designed and tested to withstand the loads produced by the winch motor when operated from a stationary vehicle. Always remember that the winch and winch cable are NOT designed for shock loading.

WINCH MAINTENANCE AND SERVICE SAFETY

 **WARNING**

Improper or lack of winch maintenance and service could lead to **SEVERE INJURY** or **DEATH**. Always follow all winch instructions and warnings in this manual.

1. Always inspect your winch before each use. Inspect for worn or kinked winch cable. Also inspect for worn or loose parts including mounting hardware.
2. Permit your winch motor to cool down prior to servicing your winch.
3. Never work on your winch without first disconnecting the battery connections to prevent accidental activation of the winch.
4. For your safety, always replace POLARIS winch parts (including the cable) with genuine POLARIS replacement parts available at your authorized POLARIS dealer, or other qualified person.
5. Some winch models use wire rope as the winch cable. Other winches use a specially designed synthetic rope as the winch cable.
6. Never replace a synthetic-rope winch cable with a consumer-grade polymer rope such as can be purchased in a hardware store. Although they may look similar, they are **NOT** alike. A polymer rope not designed for winch use will stretch and store excessive energy when winching.

 **WARNING**

Failure of a stretched rope under winching conditions will release all of the stored energy. This will increase the chances of **SEVERE INJURY** or **DEATH**.

EMISSION CONTROL SYSTEMS

NOISE EMISSION CONTROL SYSTEM

Do not modify the engine, intake or exhaust components, as doing so may affect compliance with U.S.A. EPA noise control requirements (40 CFR 205) and local noise level requirements.

OPERATION ON PUBLIC LANDS IN THE U.S.A.

Your vehicle has a spark arrester that was tested and qualified to be in accordance with the USFS standard 5100-1a. Federal law requires that this spark arrester be installed and functional when the vehicle is operated on public lands.

Operation of off-road vehicles on public lands in the U.S.A. is regulated by 43 CFR 420. Violations are subject to monetary penalties. Federal regulations can be viewed online at <https://ecfr.federalregister.gov/current/title-43/subtitle-B/chapter-I/part-420>.

CRANKCASE EMISSION CONTROL SYSTEM

This engine is equipped with a closed crankcase system. Blow-by gases are forced back to the combustion chamber by the intake system. All exhaust gases exit through the exhaust system.

EXHAUST EMISSION CONTROL SYSTEM

Exhaust emissions are controlled by engine design. An electronic fuel injection (EFI) system controls fuel delivery. The engine and EFI components are set at the factory for optimal performance and are not adjustable.

The emissions label is located on the right front frame of the vehicle.

ELECTROMAGNETIC INTERFERENCE

This spark ignition system complies with Canadian ICES-002.

This vehicle complies with the EMC requirements of UN ECE Regulation 10.

Non-ionizing Radiation: This vehicle emits some electromagnetic energy. People with active or non-active implantable medical devices (such as heart monitoring or controlling devices) should review the limitations of their device and the applicable electromagnetic standards and directives that apply to this vehicle.

MAINTENANCE

PERIODIC MAINTENANCE CHART

Any qualified repair shop or person may maintain, replace or repair the emission control devices or systems on your vehicle. An authorized dealer can perform any service that may be necessary for your vehicle. POLARIS also recommends POLARIS parts for emissions-related service, however equivalent parts can be used.

It is a potential violation of the Clean Air Act if a part supplied by an aftermarket parts manufacturer reduces the effectiveness of the vehicle's emission controls. Tampering with emission controls is prohibited by federal law.

Owners are responsible for performing the scheduled maintenance identified in this owner's manual.

Careful periodic maintenance will help keep your vehicle in the safest, most reliable condition. Inspection, adjustment and lubrication of important components are explained in the periodic maintenance chart.

Inspect, clean, lubricate, adjust and replace parts as necessary. When inspection reveals the need for replacement parts, genuine POLARIS parts are available from your POLARIS dealer, or other qualified person. Equivalent parts may be used for emissions-related service.

Service and adjustments are important for proper vehicle operation. If you're not familiar with safe service and adjustment procedures, a qualified dealer can perform these operations.

Vehicles subjected to heavy or severe use patterns must be inspected and serviced more frequently.

SEVERE USE DEFINITION

- Frequent immersion in mud, water or sand
- Frequent or prolonged operation in dusty environments
- Short trip cold weather operation
- Racing or race-style high RPM use
- Prolonged low speed, heavy load operation
- Extended idle

Pay special attention to the oil level. A rise in oil level during cold weather can indicate contaminants collecting in the oil sump or crankcase. Change oil immediately if the oil level begins to rise. Monitor the oil level, and if it continues to rise, discontinue use and determine the cause. Your authorized dealer can assist.

MAINTENANCE

MAINTENANCE INTERVAL CHART



WARNING

Improperly performing the procedures marked with a **D** could result in component failure and lead to serious injury or death. Have an authorized POLARIS dealer or other qualified person perform these services.

SYMBOL	DESCRIPTION
XU	Perform these procedures more often for vehicles subjected to severe use.
D	Have an authorized POLARIS dealer or other qualified person perform these services.

Perform all services at whichever maintenance interval is reached first. Record maintenance and service in the Maintenance Log.

ITEM	MAINTENANCE INTERVAL (WHICHEVER COMES FIRST)			REMARKS
	HOURS	CALENDAR	MILES (KM)	
Steering		Pre-Ride		Inspect and make adjustments as needed.
Front Suspension				
Rear Suspension				
Tires				
Brake Fluid Level				
Brake Lever Travel				
Brake System				
Wheels / Fasteners				
CV Boot				
Frame Fasteners				
Engine Oil Level				
Winch (If Equipped)				
XU Air Filter (Pre-Filter)	-	Daily	-	Inspect; clean often; replace as needed
Air Box Sediment Tube	-	Daily	-	Drain deposits when visible
Coolant	-	Daily	-	Check level daily, change coolant every five years
Head Lights / Tail Lights	-	Daily	-	Check operation; apply dielectric grease if replacing

MAINTENANCE

ITEM		MAINTENANCE INTERVAL (WHICHEVER COMES FIRST)			REMARKS
		HOURS	CALENDAR	MILES (KM)	
	Power Steering Unit (If Equipped)	-	Daily		Inspect daily, clean often
XU	Air Filter (Main Element)	-	Weekly	-	Inspect; replace as needed
XU	Engine Oil Change	25 H	1 M	-	Break-in oil and filter change
XU	Front Gearcase Fluid	25 H	1 M	250 (400)	Break-in fluid level check
XU	Rear Gearcase Oil	25 H	1 M	250 (400)	Break-in fluid level check
XU	Transmission Oil	25 H	1 M	250 (400)	Break-in fluid level check
XU	General Lubrication	50 H	3 M	500 (800)	Lubricate all fittings, pivots, cables, etc.
	Shift Linkage	50 H	3 M	500 (800)	Inspect
D	Steering	50 H	6 M	500 (800)	Lubricate
XU	Throttle Release Switch	50 H	6 M	500 (800)	Inspect; adjust; lubricate; replace if necessary
	Throttle Body Intake Duct	50 H	6 M	500 (800)	Inspect ducts for proper sealing / air leaks
	Drive Belt	50 H	6 M	500 (800)	Inspect ducts for proper sealing / air leaks. Inspect belt and replace as needed.
	Cooling System	50 H	6 M	1000 (1600)	Inspect coolant strength seasonally; pressure test system yearly
XU	Radiator	50 H	6 M	1000 (1600)	Inspect; clean external surfaces
XU	Cooling Hoses	50 H	6 M	1000 (1600)	Inspect for leaks
	Battery	100 H	6 M	1000 (1600)	Check terminals; clean; test
XU	Oil Lines and Fasteners	100 H	6 M	1000 (1600)	Inspect for leaks and loose fittings
XU	Engine Oil Change	100 H	12 M	1000 (1600)	Change the oil and filter
XU	Front Gearcase Fluid (Normal Use)	100 H	12 M	1000 (1600)	Change fluid
XU	Rear Gearcase Oil	100 H	12 M	1000 (1600)	Change fluid
XU	Transmission Oil	100 H	12 M	1000 (1600)	Change fluid

MAINTENANCE

ITEM		MAINTENANCE INTERVAL (WHICHEVER COMES FIRST)			REMARKS
		HOURS	CALENDAR	MILES (KM)	
D	Fuel System	100 H	12 M	1000 (1600)	Cycle key to pressurize fuel pump; check for leaks at fill cap, fuel lines/rail and fuel pump
XU	Spark Plug	100 H	12 M	1000 (1600)	Inspect; replace as needed
XU D	Brake Pad Wear	100 H	12 M	1000 (1600)	Inspect periodically
XU	Engine Mounts	100 H	12 M	1000 (1600)	Inspect
	Exhaust Pipe / Silencer	100 H	12 M	1000 (1600)	Inspect
XU	Wiring	100 H	12 M	1000 (1600)	Inspect for wear, routing, security; apply dielectric grease to connectors subjected to water, mud, etc.
D	Clutches (Drive / Driven)	100 H	12 M	1000 (1600)	Inspect; clean; replace worn parts
D	Wheel Bearings	100 H	12 M	1000 (1600)	Inspect; replace as needed
D	Brake Fluid	200 H	24 M	2000 (3200)	Change every two years
	Spark Arrestor	300 H	36 M	3000 (4800)	Clean out; or remove clean out plug
XU	Coolant	-	60 M	-	Replace coolant (50/50 Extended Life Coolant)
XU	Valve Clearance	500 H	-	5000 (8000)	Inspect; adjust as needed
D	Toe Adjustment		-		Inspect periodically; adjust as needed
	Headlight Aim		-		Adjust as needed

LUBRICATION GUIDE

Check and lubricate all components at the intervals outlined in the Maintenance Interval Chart. Items not listed in the chart should be lubricated at the General Lubrication interval.

The a-arms and lower control arms are lubricated at the factory, and no additional lubrication will be needed.

ITEM	RECOM-MENDED LUBRICANT	CAPACITY AT FLUID CHANGE	FILL PLUG TORQUE	DRAIN PLUG TORQUE	SEE PAGE
Engine Oil	PS-4 5W-50 4-Cycle Oil	2 qt. (1.9 l)	—	12 ft-lbs (16 N·m)	page 94
Transmission Oil	AGL Gearcase Lubricant & Transmission Fluid	37 oz. (1100 ml)	12 ft-lbs (16 N·m)	12 ft-lbs (16 N·m)	page 97
Demand Drive Fluid (Front Gearcase)	Demand Drive Fluid	9.3 oz. (275 ml)	19 ft-lbs (26 N·m)	19 ft-lbs (26 N·m)	page 99
Rear Gearcase Oil	ATV Angle Drive Fluid (or GL5 80-90 weight gear lube)	7.1 oz. (210 ml)	12 ft-lbs (16 N·m)	12 ft-lbs (16 N·m)	page 101
Brake Fluid	DOT 4 Brake Fluid	—	—	—	page 36
Front Prop Shaft Yoke	U-Joint Grease	Grease fittings (3 pumps maximum) every 500 miles, before long periods of storage, or after pressure washing or submerging.			

ENGINE OIL

WARNING

Vehicle operation with insufficient, deteriorated, or contaminated engine oil will cause accelerated wear and may result in engine seizure, accident and injury.

Always check and change the engine oil at the intervals outlined in the Maintenance Interval Chart. Always use the recommended engine oil.

Pay special attention to the oil level. A rise in oil level during cold weather can indicate contaminants collecting in the oil sump or crankcase. Change oil immediately if the oil level begins to rise. Monitor the oil level, and if it continues to rise, discontinue use and determine the cause. Your authorized dealer can assist.

OIL RECOMMENDATIONS

IMPORTANT

Always change the oil filter when you change the engine oil.

POLARIS recommends the use of POLARIS PS-4 Full Synthetic 5W-50 4-cycle oil or a similar oil for this engine. Oil may need to be changed more frequently if POLARIS oil is not used. Always use 5W-50 oil. Follow the manufacturer's recommendations for ambient temperature operation.

See the Lubrication Guide section for fluid recommendations, capacities, and plug torques.

IMPORTANT

Mixing brands or using a non-recommended oil may cause serious engine damage. Always use the recommended oil. Never substitute or mix oil brands.

OIL LEVEL CHECK

IMPORTANT

Check the oil level when the engine is cold. Never check the oil with the engine running or damage to the dipstick and / or engine could occur.



To check the oil level, do the following:

1. Position the vehicle on a level surface.
2. Access the oil dipstick and fill tube from the left side of the ATV ①. Remove the dipstick. Wipe it dry with a clean cloth.
3. Reinstall and tighten the dipstick.
4. Remove the dipstick and check the oil level.
5. Add the recommended fluid as needed. Maintain the oil level in the safe range between the FULL and ADD marks. Do NOT overfill.
6. Reinstall and tighten the dipstick.

MAINTENANCE

OIL AND OIL FILTER CHANGE

IMPORTANT

Always change the oil filter when you change the engine oil.

The engine oil and oil filter should be changed in accordance with the Maintenance Interval Chart. See the Lubrication Guide section for fluid recommendations and capacities.

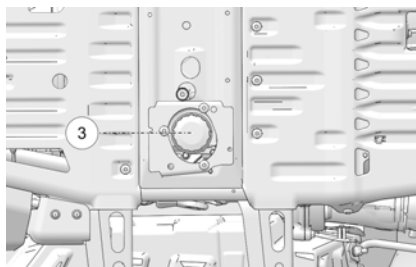

1. Position the vehicle on a level surface.
2. Clean the area around the drain plug ①.
3. Place a drain pan under the crankcase.
4. Remove the drain plug ①. Allow the oil to drain completely.

CAUTION

Hot oil can cause burns to skin. Do not allow hot oil to contact skin.

5. Install a new sealing washer on the drain plug. The sealing surfaces on drain plug and crankcase should be clean and free of burrs, nicks or scratches.
6. Reinstall the drain plug. Torque to specification.
7. Remove the oil filter cover plate ② by loosening the three screws holding into place.
8. Place shop towels beneath the oil filter ③. Using an oil filter wrench (available from your POLARIS dealer), turn the filter counter-clockwise to remove it.
9. Using a clean dry cloth, clean the filter sealing surface on the crankcase.
10. Lubricate the o-ring on the new filter with a film of fresh engine oil. Check to make sure the o-ring is in good condition.

11. Install the new filter and rotate it clockwise by hand until the filter gasket contacts the sealing surface, then turn it an additional 3/4 turn.
12. Remove the dipstick. Add the proper amount of the recommended oil. Do not overfill.
13. Reinstall the dipstick.
14. Place the transmission in PARK.
15. Lock the parking brake.
16. Start the engine. Allow it to idle for one to two minutes.
17. Stop the engine.
18. Check for leaks.
19. Check the oil level. Add oil as needed to bring the level to the upper mark on the dipstick.
20. Dispose of used filter and oil properly.

TRANSMISSION OIL

Always check and change the transmission oil at the intervals outlined in the Maintenance Interval Chart. See the Lubrication Guide section for fluid recommendations, capacities, and plug torques. Maintain the oil level at the bottom of the fill plug hole ①.

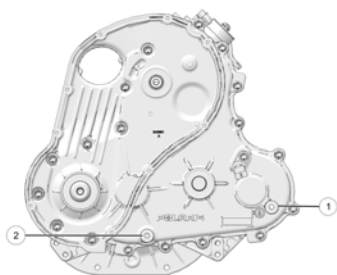

The fill plug is located on the right side of the ATV behind the footwell. The drain plug ② is located on the bottom rear side of the gearcase.

OIL CHECK

1. Remove the footwell.
2. Remove the fill plug. Check the oil level.
3. Add the recommended fluid as needed to bring the level to the bottom of the fill hole threads.

MAINTENANCE

4. Reinstall the fill plug. Torque to specification.

TORQUE

Fill Plug:
12 ft-lbs (16 N·m)

5. Reinstall the footwell.

OIL CHANGE

1. Remove the footwell.
2. Place a drain pan under the gearcase. Remove the drain plug. Allow the oil to drain completely.
3. Clean and reinstall the drain plug. Torque to specification.

TORQUE

Drain Plug:
12 ft-lbs (16 N·m)

4. Remove the fill plug. Add the proper amount of the recommended oil.
5. Reinstall the fill plug. Torque to specification.

TORQUE

Fill Plug:
12 ft-lbs (16 N·m)

6. Check for leaks.
7. Reinstall the footwell.
8. Dispose of used oil properly.

FRONT GEARCASE (DEMAND DRIVE) FLUID

Always check and change the demand drive fluid at the intervals outlined in the Maintenance Interval Chart.

Use the recommended fluid. Use of other fluids may result in improper operation of components. Maintain the fluid level at the bottom of the fill hole threads. The fill plug is located on the right side of the demand drive unit. The drain plug is located on the bottom right side of the unit.

FLUID CHECK

1. Position the vehicle on a level surface. Remove the fill plug ①. Check the fluid level.
2. Add the recommended fluid as needed to bring the level to the bottom of the fill hole threads.
3. Reinstall the fill plug. Torque to specification.

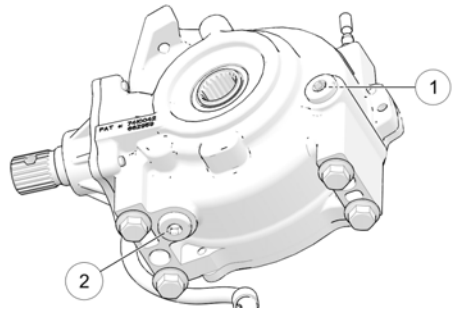

TORQUE

Fill Plug:
19 ft-lbs (26 N·m)

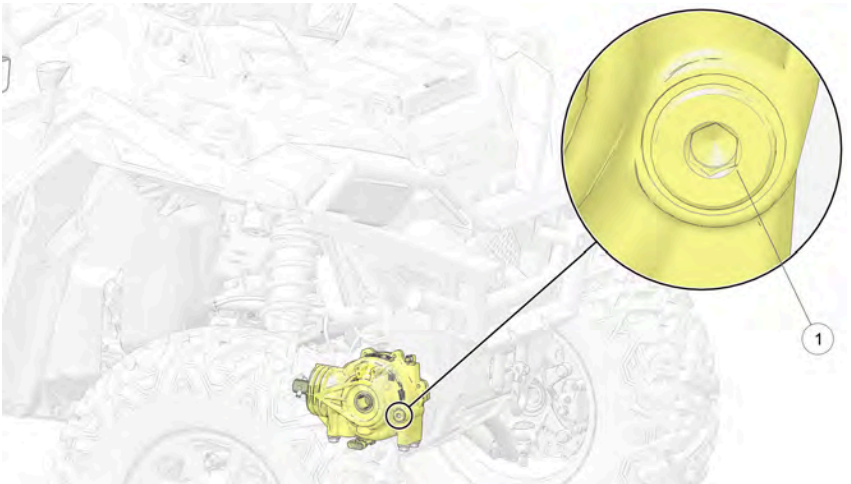

MAINTENANCE

FLUID CHANGE

1. Position the vehicle on a level surface. Remove the fill plug ①.
2. Place a drain pan under the demand drive unit. Remove the drain plug ②. Allow the fluid to drain completely.
3. Clean and reinstall the drain plug. Torque to specification.

TORQUE
Drain Plug: 19 ft-lbs (26 N·m)

4. Add the recommended fluid as needed to bring the level to the bottom of the fill hole threads.
5. Reinstall the fill plug. Torque to specification.

TORQUE
Fill Plug: 19 ft-lbs (26 N·m)

6. Check for leaks. Dispose of used fluid properly.

REAR GEARCASE OIL

Always check and change the rear gearcase oil at the intervals outlined in the Maintenance Interval Chart. See the Lubrication Guide section for fluid recommendations, capacities, and plug torques.

The fill plug is located on the rear of the gearcase. The drain plug is located on the bottom of the gearcase.

Maintain the fluid level at the bottom of the fill hole threads. Do not overfill.

OIL CHECK

1. Position the vehicle on a level surface.
2. Remove the fill plug ①. Check the oil level.
3. Add the recommended oil as needed to bring the level to the bottom of the fill hole threads. *Do not overfill.*
4. Reinstall the fill plug. Torque to specification.

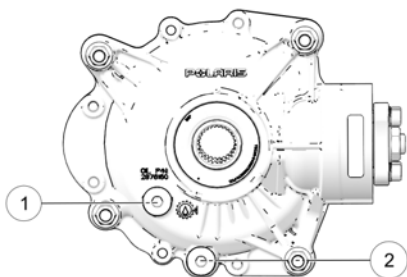

TORQUE

Fill Plug:
12 ft-lbs (16 N·m)

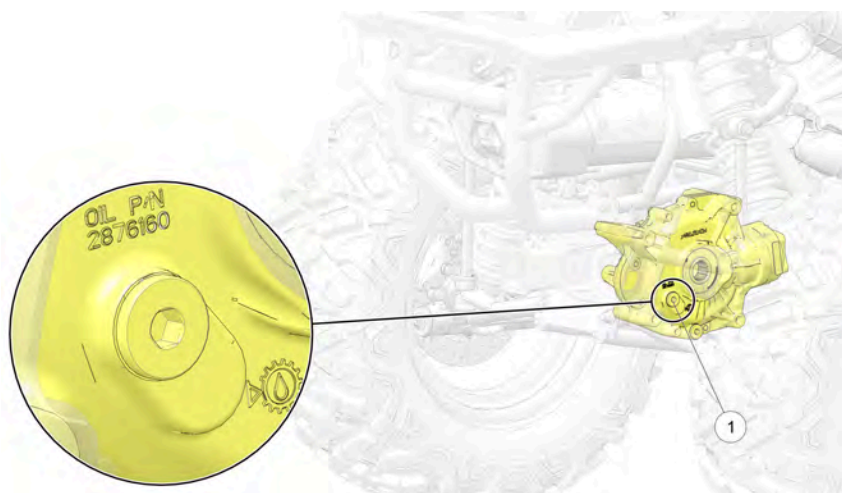

OIL CHANGE

1. Position the vehicle on a level surface.
2. Place a drain pan under the drain hole ②.
3. Remove the drain plug. Allow the oil to drain completely.
4. Clean and reinstall the drain plug with a new sealing washer. Torque to specification.

TORQUE

Drain Plug:
12 ft-lbs (16 N·m)

5. Remove the fill plug. Add the proper amount of the recommended oil. *Do not overfill.*
6. Reinstall the fill plug. Torque to specification.

TORQUE

Fill Plug:
12 ft-lbs (16 N·m)

7. Check for leaks.
8. Dispose of used oil properly.

POWER STEERING UNIT (IF EQUIPPED)

If your model is equipped with power steering, frequently clean the areas around and on the power steering unit to allow proper cooling. Clean these areas ① thoroughly.

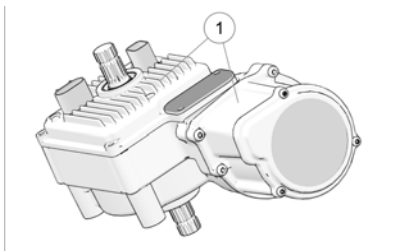

STEERING ASSEMBLY

The steering assembly of the ATV should be checked periodically for loose nuts and bolts. If loose nuts and bolts are found, see your authorized dealer or other qualified service facility before operating the vehicle.

COOLING SYSTEM

The engine coolant level is controlled, or maintained, by the recovery system. The recovery system components are the recovery bottle, the radiator filler neck, the radiator pressure cap and the connecting hose.

As coolant operating temperature increases, the expanding (heated) excess coolant is forced out of the engine, past the pressure cap, and into the recovery bottle. As engine coolant temperature decreases the contracting (cooled) coolant is drawn back up from the bottle, past the pressure cap, and into the radiator.

Some coolant level drop on new vehicles is normal as the system is purging itself of trapped air. Check the coolant level and maintain as recommended by adding coolant to the recovery bottle.

POLARIS recommends the use of POLARIS Antifreeze 50/50 Premix. This antifreeze is already premixed and ready to use. Do not dilute with water. See the Polaris Products section for the part numbers.

RECOVERY BOTTLE COOLANT

The recovery bottle fluid level can be viewed from inside the front right wheel well. Access the recovery bottle cap under the front box.

1. View the fluid level in the bottle.
2. If the level is low, remove the bottle cap and add coolant as needed. Maintain the coolant level between the minimum and maximum marks on the bottle (when the fluid is cool).
3. Reinstall the cap.
4. Close and secure the front box and cover.

MAINTENANCE

RADIATOR COOLANT

To ensure that the coolant maintains its ability to protect the engine, we recommend that the system be completely drained every five (5) years and fresh Antifreeze 50/50 Premix added.

Any time the cooling system has been drained for maintenance or repair, replace the coolant with fresh Antifreeze 50/50 Premix. If the recovery bottle has run dry, check the level in the radiator. Add coolant as needed.

 CAUTION

Escaping steam can cause burns. Never remove the pressure cap while the engine is warm or hot. Always allow the engine to cool before removing the pressure cap.

1. Access the pressure cap under the front box. See the Front Compartment section for details.
2. Remove the pressure cap.
3. Using a funnel, slowly add coolant through the radiator filler neck.
4. Reinstall the pressure cap. Use of a non-standard pressure cap will not allow the recovery system to function properly. Your POLARIS dealer can provide the correct replacement part.
5. Close and secure the front box and cover.

BRAKES

HAND BRAKE

 CAUTION

Brake discs can become extremely hot after operation. Allow the discs to cool before performing maintenance to prevent risk of burns.

The front and rear brakes are hydraulic disc brakes, activated by moving the single brake lever toward the handlebar. These brakes are self-adjusting.

Under normal operation, the diaphragm extends into the reservoir as fluid level drops. The diaphragm is inside, under the reservoir cap, integrated into the seal for the master cylinder. If the fluid level is low and the diaphragm is not extended, a leak is likely and the diaphragm should be replaced. To ensure proper diaphragm operation, always fill the reservoir as needed whenever the cover is loosened or removed. Do not overfill.

 **WARNING**

An over-full master cylinder may cause brake drag or brake lock-up, which could result in serious injury or death. Maintain brake fluid at the recommended level. Do not overfill.

The following checks are recommended to keep the brake system in good operating condition. Check more often if brakes are used heavily under normal operation.

1. Always keep brake fluid at an adequate level. See the Master Cylinder/Brake Fluid section for details.
2. Check the brake system for fluid leaks.
3. Check the brakes for excessive travel or spongy feel.
4. Check the friction pads for wear, damage and looseness. Replace brake pads when they are worn to .030" (0.762 mm).
5. Check the security and surface condition of the disc. Clean any grease using a recommended brake cleaner or alcohol. Do not use spray lubricants or other petroleum-based products. If you discover any damage (cracks, excessive corrosion, warping) see your dealer for service before operating.

AUXILIARY FOOT BRAKE

The hydraulic auxiliary brake system requires no adjustment. Check the brake fluid level frequently for the auxiliary brake system. See page 36 for more information.

SEAT REMOVAL

1. Grasp one side of the seat near the rear edge.
2. Pull upward abruptly to disengage the under-seat fasteners.
3. Remove the seat.

SIDE PANEL/FOOTWELL REMOVAL

Remove the seat before removing a side panel. To remove a side panel or footwell, remove the fasteners securing it to the frame. Lift the right side panel upward while removing it to clear the shifter knob.

TIRES

WARNING

Operating your ATV with worn tires, improperly inflated tires, non-standard tires or improperly installed tires will affect vehicle handling and could cause an accident resulting in serious injury or death. Always follow all tire maintenance procedures as outlined in this manual and on the labels on the vehicle. Always use original equipment size and type when replacing tires.

Refer to the specifications section for recommended tire type, size and pressure.

TIRE TREAD DEPTH

Always replace tires when tread depth is worn to 3 mm (1/8") or less.

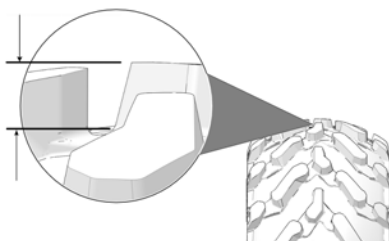

WHEEL REMOVAL

1. Stop the engine.
2. Place the transmission in PARK.
3. Lock the parking brake.
4. Loosen the wheel nuts slightly.

WARNING

Do not service axle nuts that have a cotter pin installed. Your authorized dealer can assist.

5. Elevate the side of the vehicle by placing a suitable stand under the foot rest frame.
6. Remove the wheel nuts.
7. Remove the wheel.

WHEEL INSTALLATION

1. Place the transmission in PARK.
2. Lock the parking brake.
3. Place the wheel on the hub with the valve stem toward the outside and rotation arrows on the tire pointing toward forward rotation (if equipped).
4. Install the wheel nuts and finger-tighten them.
5. Lower the vehicle to the ground.
6. Torque the wheel nuts to specification.

 **WARNING**

Loose nuts could cause a tire to come off during operation, which could result in an accident or overturn. Always ensure that all nuts are torqued to specification.

WHEEL NUT TORQUE SPECIFICATIONS

Check the wheel nut torques occasionally and when they've been loosened for service.

WHEEL TYPE	NUT TORQUE
Aluminum Wheel Lug Nuts	120 ft-lbs (162 N·m)

TOE ALIGNMENT

WARNING

Severe injury or death can result from improper toe alignment and adjustment. Do not attempt to adjust tie rod alignment. All tie rod adjustments should be performed by an authorized POLARIS dealer or other qualified service facility.

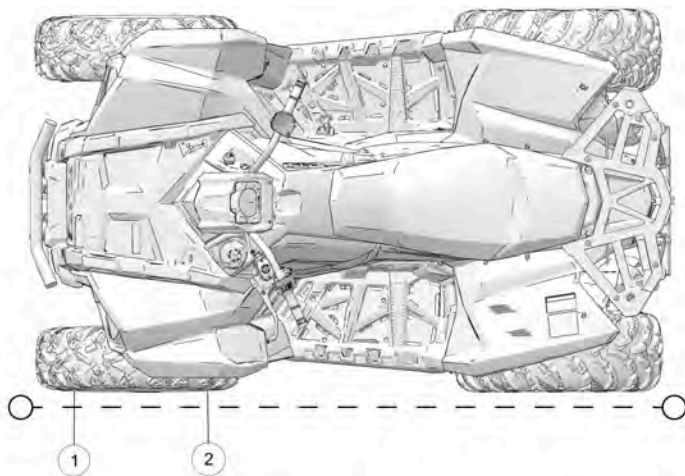

Use the following procedure to check the toe alignment of the vehicle. The recommended toe alignment is 1/4-1/2 inch (6-12 mm).

1. Position the vehicle on a level surface.
2. Place the handlebars in a straight-ahead position.
3. Tie a length of string between two stands as shown in the illustration. Position the stands so that the string is flush with the side of the rear tire. If available, you may use a long straight-edge instead of string.
4. Measure the distance from the string to the rim at the front ① and rear ② of the front rim. The rear measurement should be 1/8-1/4 inch (3-6 mm) more than the front measurement on each side of the vehicle to obtain the recommended 1/4-1/2 inch (6-12 mm) toe out alignment.
5. Repeat the measurement procedure on the other side of the vehicle.
6. If you discover improper alignment, see your POLARIS dealer for service.

CAMBER AND CASTER

The camber and caster are non-adjustable.

AIR FILTER INSTALLATION

1. Remove the seat, the air box cover strap ②, and remove the air box cover ①.

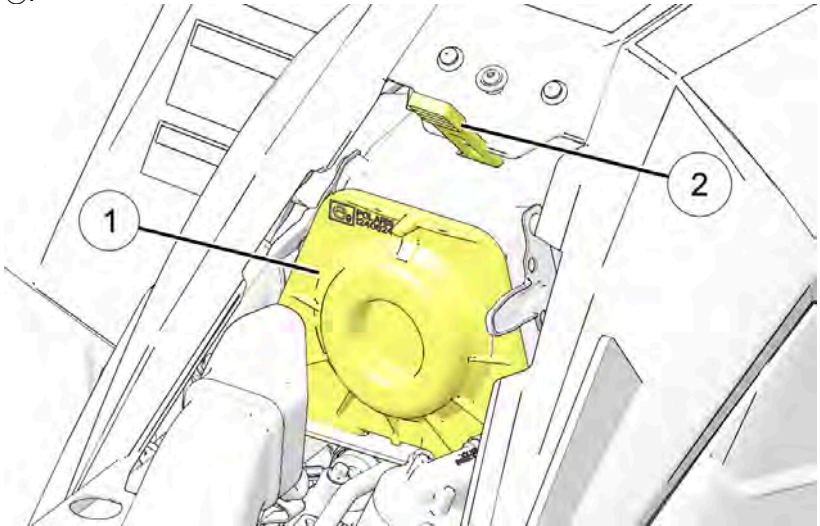

2. Remove the filter ③.

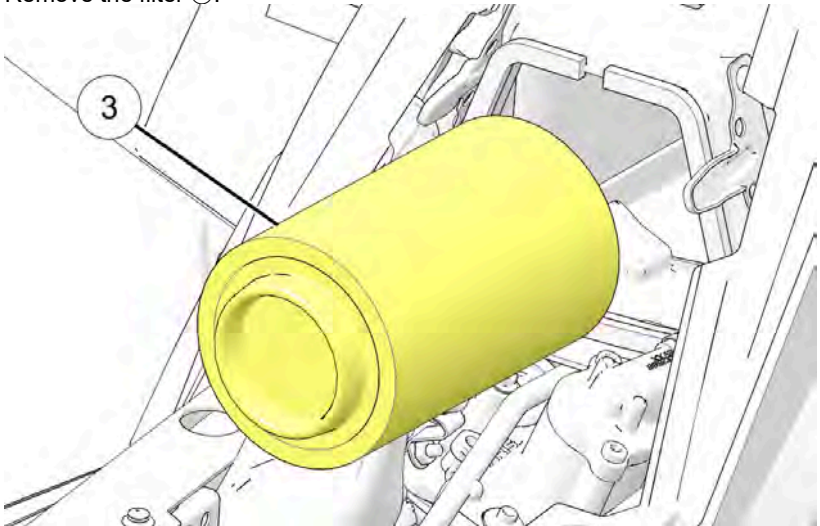

MAINTENANCE

3. Remove the fabric type pre-filter ④ from the main filter ⑤. Wash the pre-filter in soapy water, then rinse and let dry.

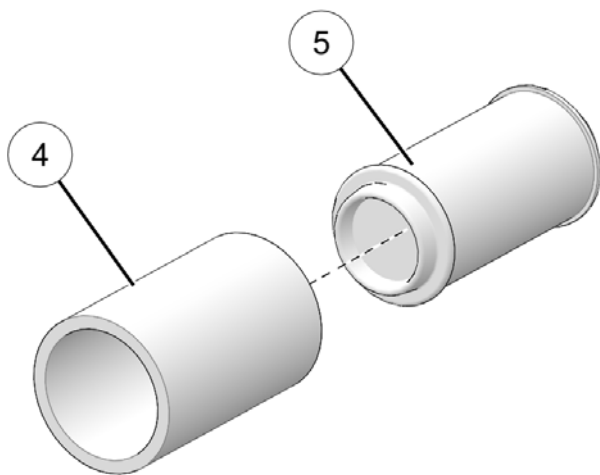

4. Reinstall the pre-filter over the main filter. Install a new main filter if needed.
5. Reinstall the filter into the air box.
6. Reinstall the air box cover and the seat.

FUSE REPLACEMENT

If the engine stops or will not start, or if you experience other electrical failures, a fuse may need replacement. Locate and correct any short circuits that may have caused the blown fuse, then replace the fuse.

Spare fuses are provided in the fuse box.

1. Access the fuses under the front box.

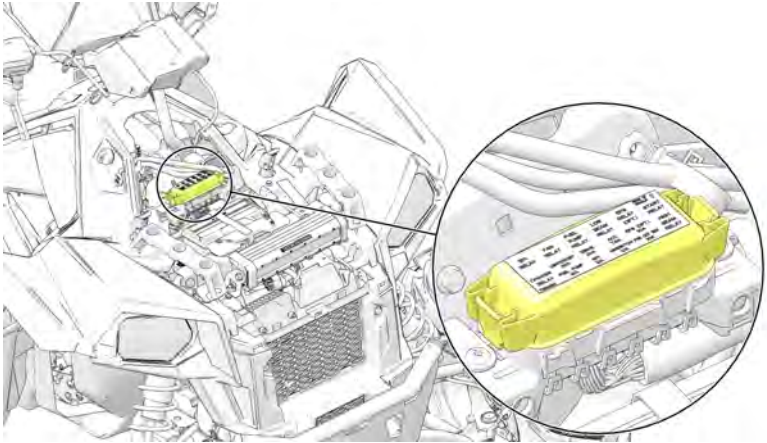

2. Remove the fuse box cover.

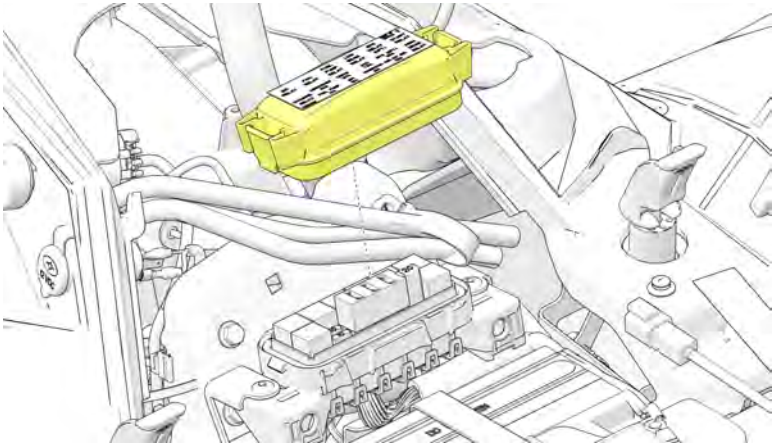

3. Remove the suspect fuse from the fuse panel. If the fuse is blown, install a new fuse with the same amperage rating.
4. Reinstall the fuse box cover.
5. Close and secure the front box and cover.

MAINTENANCE

SCRAMBLER XP 1000 S

SPARE 20A	FAN CKT BKR 20A	UN- SWITCH- ED 10A	EFI 10A	FUEL PUMP 10A	CHASSIS RELAY
SPARE 20A	EPS 30A	ACCES- SORY 20A	DRIVE 20A	LIGHTS 20A	
START RELAY	EPS RELAY		FUEL PUMP RELAY	FAN RELAY	EFI RELAY
		SPARE 30A			

LIGHTS

HEADLIGHT BEAM INSPECTION

Poor lighting can result in reduced visibility when driving. Headlight and taillight lenses become dirty during normal operation. Clean lights frequently and replace burned out lamps promptly. Always make sure lights are adjusted properly for best visibility.

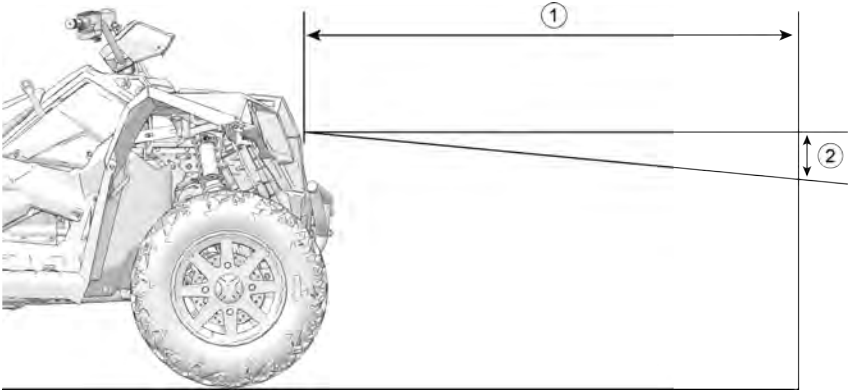

The headlight beam can be adjusted slightly upward or downward. Use the following procedure to make the adjustment.

1. Position the vehicle on a level surface with the headlight approximately 25 ft. (7.6 m) from a wall ①. Place the transmission in PARK.
2. Measure the distance from the floor to the center of the headlight and make a mark on the wall at the same height.
3. Start the engine. Turn the headlight switch to high beam.
4. Observe the headlight aim on the wall. The most intense part of the headlight beam should be 2 in. (5 cm) below the mark on the wall ②. Include rider weight on the seat when measuring.
5. The adjustment screw is located on the left side of the headlight pod. To adjust the beam, loosen the screw. Adjust the headlamp to the desired position, then tighten the screw.

MAINTENANCE

HEADLIGHT BEAM ADJUSTMENT

The headlight beam can be adjusted horizontally and vertically.

Tighten or loosen one or more of the three headlight adjustment screws ① to adjust the beam upward or downward or to the left or right.

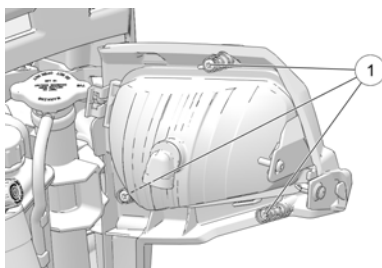

HEADLAMP REPLACEMENT

If a headlight becomes damaged or inoperable, the entire headlight assembly must be replaced. An authorized dealer can assist.

TAILLIGHT/BRAKE LIGHT LAMP REPLACEMENT

The taillight assembly is not serviceable. If the light fails to operate properly, replace the entire taillight assembly.

SPARK PLUGS

SPARK PLUG RECOMMENDATIONS

Refer to the specifications section for the recommended spark plug type and gap for your vehicle. Torque spark plugs to specification.

NOTICE

Using non-recommended spark plugs can result in serious engine damage. Always use POLARIS-recommended spark plugs or their equivalent.

PLUG CONDITION	TORQUE SPECIFICATION
New Spark Plug	15 ft-lbs (20 N·m)
Previously Installed Spark Plug	15 ft-lbs (20 N·m)

SPARK PLUG INSPECTION

Spark plug condition is indicative of engine operation. Check the spark plug for the correct color.

CAUTION

A hot exhaust system and engine can cause burns. Wear protective gloves when removing a spark plug for inspection. Allow engine to cool before removing spark plug wire.

1. Rotate the spark plug cap ① 1/4 turn and pull it off the spark plug.

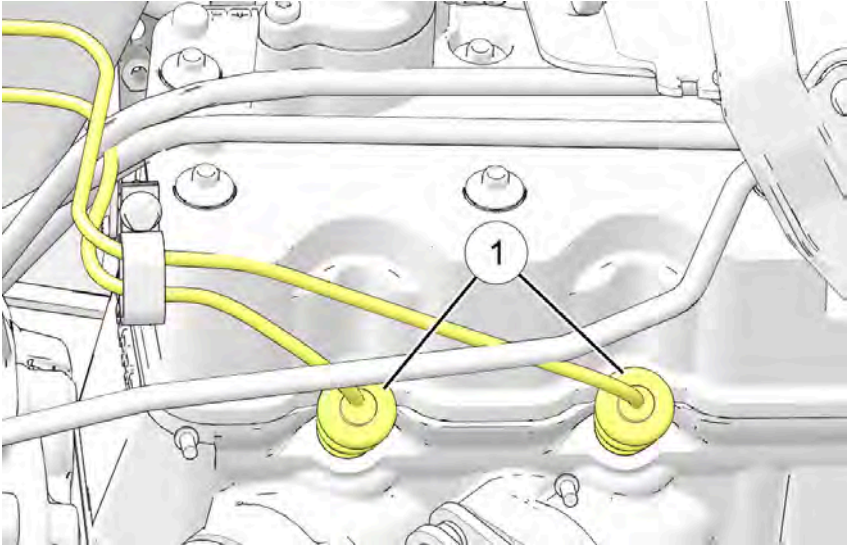

2. Rotate the spark plug counter-clockwise to remove it.
3. Reverse the procedure for spark plug installation. Torque to specification.

NORMAL PLUG

The normal insulator tip is gray, tan or light brown. There will be few combustion deposits. The electrodes are not burned or eroded. This indicates the proper type and heat range for the engine and the service.

The tip should not be white. A white insulator tip indicates overheating, caused by use of an improper spark plug or lean air/fuel ratio.

WET FOULED PLUG

The wet fouled insulator tip is black. A damp oil film covers the firing end. There may be a carbon layer over the entire nose. Generally, the electrodes are not worn. General causes of fouling are excessive oil consumption, use of non-recommended oil, or poor fuel quality.

VEHICLE IMMERSION

If your vehicle becomes immersed, major engine damage can result if the machine is not thoroughly inspected. Take the vehicle in for service before starting the engine. Your POLARIS dealer can provide this service.

If it's impossible to take your ATV to a dealer before starting it, follow the steps outlined below.

1. Move the ATV to dry land or at the very least, to water below the footrests.
2. Check the air box. If water is present, dry the air box and replace the filter with a new filter. If equipped, remove the air box drain plug to drain water. Reinstall the drain plug. Make sure the E-ring is on the drain plug and reinstall the drain plug.

NOTICE

Serious damage could occur if the air box drain plug is not reinstalled and tightened properly.

3. Remove the spark plugs.
4. Turn the engine over several times using the electric start.
5. Dry the spark plugs. Reinstall the plugs or install new plugs.
6. Attempt to start the engine. If necessary, repeat the drying procedure.

NOTICE

Serious damage can occur after immersion if fluids are not changed promptly. Your POLARIS dealer can assist.

7. Take the vehicle in for service as soon as possible, whether you succeed in starting it or not. Your POLARIS dealer can provide the required service.
8. If water has been ingested into the PVT, follow the procedure on page 120 for drying out the PVT.

SPARK ARRESTER

 **WARNING**

Failure to heed the following warnings while servicing the spark arrester could result in serious injury or death.

- Never run the engine in an enclosed area. Exhaust contains poisonous carbon monoxide gas that can cause loss of consciousness or death in a very short time.
- Wear eye protection and leather work gloves.
- Do not perform clean-out immediately after the engine has been run, as the exhaust system becomes very hot. Serious burns could result from contact with the exhaust components. Allow components to cool sufficiently before proceeding.

Never operate without the spark arrester

MAINTENANCE

Periodically clean the spark arrester to remove accumulated carbon.

1. Place the transmission in PARK.
2. Remove the four arrester cap bolts and remove the cap.

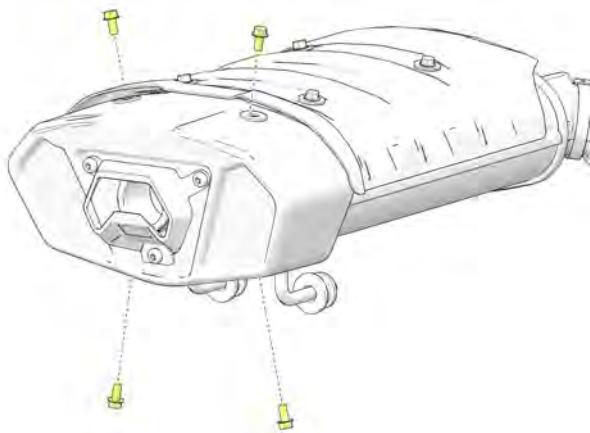

3. Remove the arrester retaining bolt and nut.

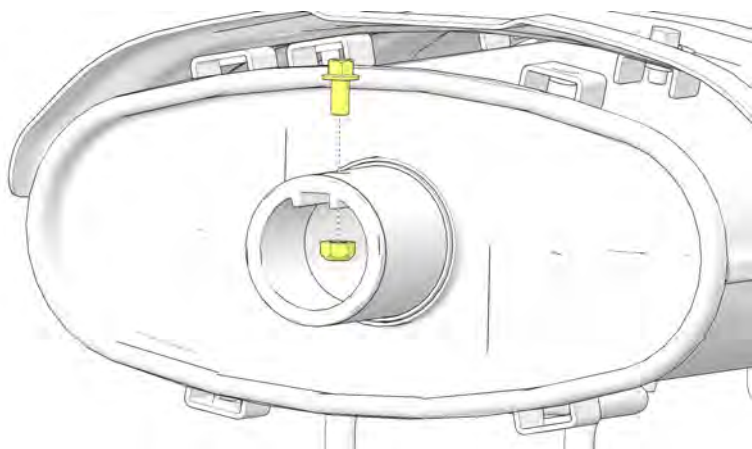

4. Remove the arrester from the end of the muffler.

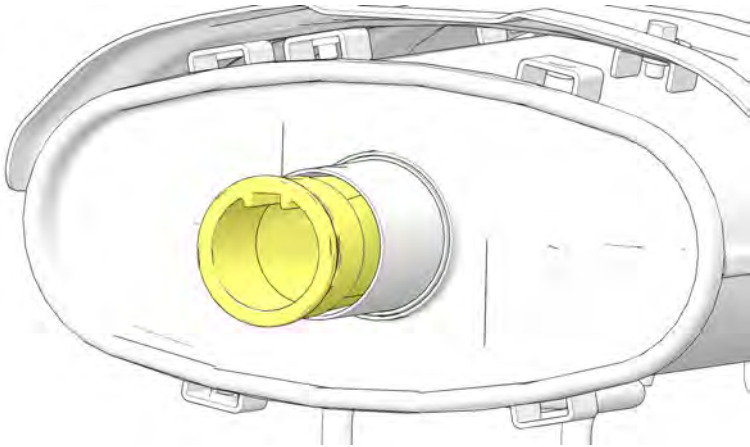

5. Use non-synthetic brush to clean the arrester screen. A synthetic brush may melt if the components are warm. If necessary, blow debris from the screen with compressed air.
6. Inspect the screen for wear and damage. Replace a worn or damaged screen.
7. Reinstall the arrester.
8. Torque the retainer bolt to specification.

TORQUE
Retainer Bolt: 10 ft-lbs (14 N·m)

9. Reinstall the arrester cap and bolts. Torque to specification.

TORQUE
Cap Bolts: 10 ft-lbs (14 N·m)

PVT SYSTEM

WARNING

Failure to comply with the instructions in this warning can result in severe injury or death.

Do not modify any component of the PVT system. Doing so may reduce its strength so that a failure may occur at a high speed. The PVT system has been precision balanced. Any modification will cause the system to be out of balance, creating vibration and additional loads on components.

The PVT system rotates at high speeds, creating large amounts of force on clutch components. Extensive engineering and testing has been conducted to ensure the safety of this product. However, as the owner, you have the following responsibilities to make sure this system remains safe:

- Always follow all recommended maintenance procedures. Always look for and remove debris inside and around the clutch and vent system when replacing the belt.
- See your POLARIS dealer, or other qualified person, for service and repair assistance.
- This PVT system is intended for use on POLARIS products only. Do not install it in any other product.
- Always make sure the PVT housing is securely in place during operation.

The basic operation of the POLARIS PVT system is dependent on engine speed and vehicle torque requirements. As engine speed increases, the force exerted on the movable drive sheave by the flyweights also increases. This, in turn, increases the amount of pinch applied to the drive belt. Similarly, if the engine speed decreases, the amount of centrifugal force decreases, reducing the amount of belt pinch.

On POLARIS ATVs, the approximate gear ratio difference between high and low range is 1:2.25. This difference in gearing affects the operation of the PVT, especially at speeds less than 7 MPH (11 km/h), due to the system's dependence on engine speed.

For example, when operating at a ground speed of 3 MPH (5 km/h) in low range, the engine speed would be around 3000 RPM. This is well above the engagement speed of 1600 - 1800 RPM. However, in high range at 3 MPH (5 km/h), the engine would be running at only 1500 RPM. Whenever operating this close to the engagement speed, the engine may be running at a speed too low to provide the pinch needed to prevent belt slip. Belt slip is responsible for creating the excessive heat that destroys belts, wears clutch components and causes outer clutch covers to fail.

The air temperature in the clutch cover is substantially reduced by using low range while operating at low ground speeds. Reducing the temperature inside the clutch cover greatly extends the life of the PVT components (belt, cover, etc.).

WHEN TO USE LOW RANGE AND HIGH RANGE

CONDITION	RANGE TO USE
Operating at speeds less than 7 MPH (11 km/h)	Low
Towing heavy loads	Low
Operating in rough terrain (swamps, mountains, etc.)	Low
Operating at speeds greater than 7 MPH (11 km/h)	High

MAINTENANCE

PVT DRYING

There may be some instances when water is accidentally ingested into the PVT system. Use the following instructions to dry it out before operating.

1. Position the vehicle on a level surface.
2. Remove the drain plug ①. Allow the water to drain completely. Reinstall the drain plug.

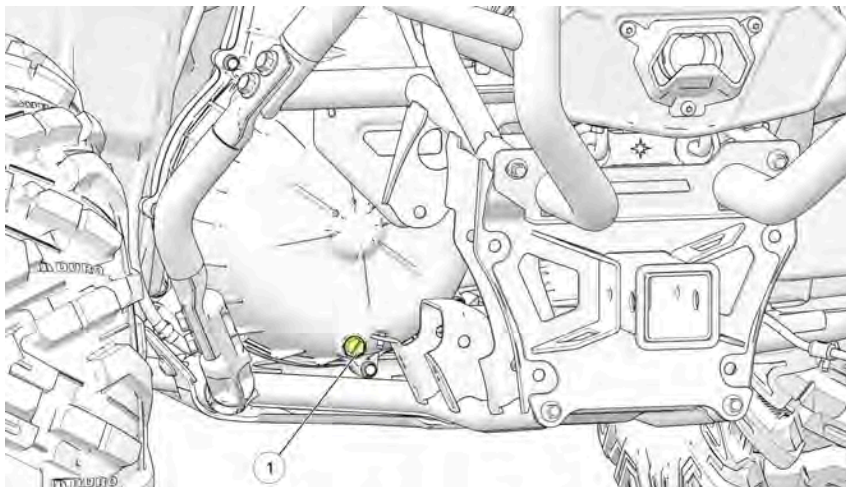

3. Start the engine. Place the transmission in PARK.
4. Apply varying throttle for 10-15 seconds to expel the moisture and air-dry the belt and clutches. Do not hold the throttle wide open for more than 5 seconds.
5. Allow the engine RPM to settle to idle speed, then shift the transmission to low range.
6. Test for belt slippage. If the belt slips, repeat the process. Your vehicle requires service as soon as possible, which your authorized dealer can provide.

DRIVE BELT REMOVAL

1. Position the vehicle on a level surface and place the transmission in PARK.
2. Elevate and safely support the rear of the vehicle.
3. Remove the left rear wheel from the vehicle.
4. Remove the (4) bolts ① retaining the lower LH frame support ② and remove from the frame.

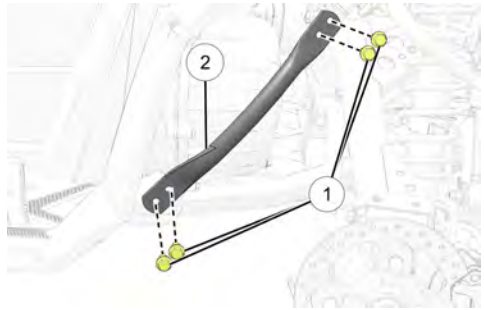

5. Remove the (11) fasteners securing the outer PVT cover to the inner PVT cover.

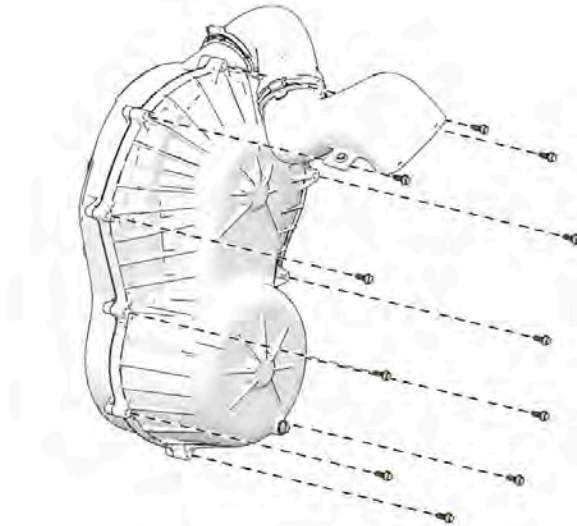

6. Using care, pull the outer PVT cover out the left rear wheel well.

NOTICE

Flexing the PVT outlet duct aids PVT cover removal.

7. Note the orientation of the drive belt so that it can be installed in the same direction.

MAINTENANCE

8. Insert the provided clutch tool between the slides and rotate the tool to spread the sheaves.

Spanner Wrench / Spreader:
PN 2877408

NOTICE

Make sure the tool is square with the moveable sheave surface of the driven clutch.

9. Once the sheaves have been spread, walk the drive belt out of the driven clutch and drive clutch, and remove it from the vehicle.

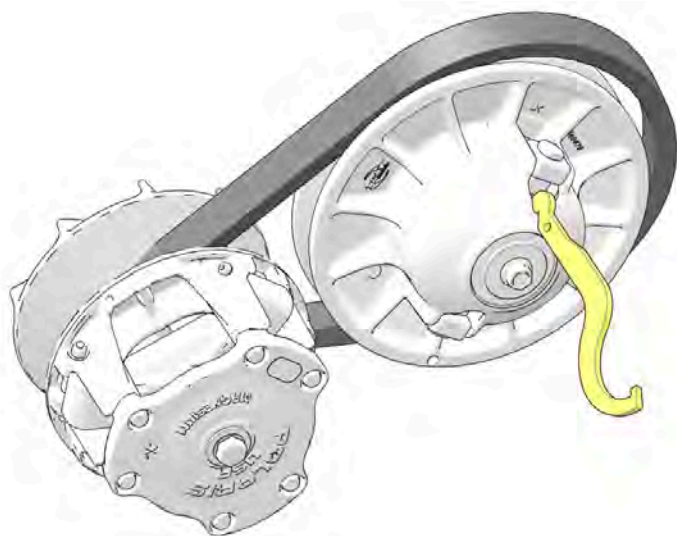

DRIVE BELT INSTALLATION

IMPORTANT

Orient the belt as it was removed or orient the new belt so that you can read the text.

1. Spread the sheaves and walk the drive belt on to the drive clutch and driven clutch.

Spanner Wrench / Spreader:
PN 2877408

NOTICE

Make sure the tool is square with the moveable sheave surface of the driven clutch.

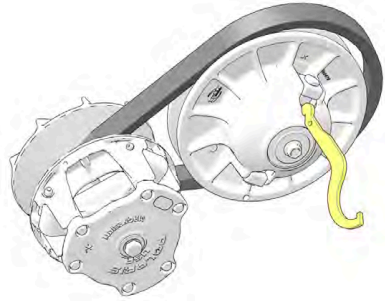

2. Release the sheaves and rotate the driven clutch counter-clockwise to make sure the sheaves close against the belt.
3. Make sure the clutch cover seal is secure in the outer PVT cover.
4. Install outer PVT cover and secure with fasteners. Torque fasteners to specification.

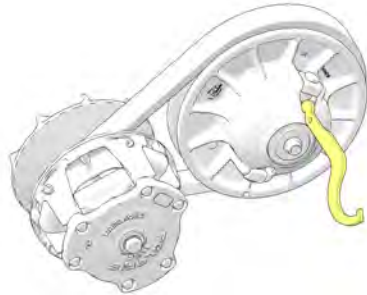

TORQUE

Outer PVT Cover Fasteners:
30 in-lbs (3 N·m)

MAINTENANCE

5. Install the (4) bolts retaining the lower LH frame support to the frame. Torque bolts to specification.

TORQUE
Lower LH Frame Support Fasteners: 45 ft-lbs (60 N·m)

6. Install the left rear wheel and torque wheel nuts to specification.

TORQUE
Wheel Lug Nuts: 120 ft-lbs (162 N·m)

7. Start the engine and test the operation of the PVT system.
8. Always break in the drive belt after a belt replacement. For drive belt break-in information, see the Operation chapter.

BATTERY

 **WARNING**

Improperly connecting or disconnecting battery cables can result in vehicle/battery damage, an explosion, or serious injury or death. When removing the battery, always disconnect the negative (black) cable first. When reinstalling the battery, always connect the negative (black) cable last.

Your ATV is equipped with a sealed battery, which requires little maintenance. POLARIS does not recommend using a conventional battery in this vehicle. The orientation of the battery could result in electrolyte leakage, which would shorten the life of the battery considerably.

Always keep battery terminals and connections free of corrosion. If cleaning is necessary, remove corrosion with a stiff wire brush. Wash with a solution of one tablespoon baking soda and one cup water. Rinse well with tap water and dry off with clean shop towels. Coat the terminals with dielectric grease or petroleum jelly.

BATTERY REMOVAL

1. Access the battery under the front box.
2. Disconnect the black (negative) battery cable first.
3. Disconnect the red (positive) battery cable last.
4. Disconnect the battery hold-down strap.
5. Lift the battery out of the ATV.

BATTERY INSTALLATION

Using a new battery that has not been fully charged can damage the battery and result in a shorter life. It can also hinder vehicle performance. Follow the instructions in the Battery Charging section before installing the battery.

An optional extreme use battery may be available for your model. If the performance of the factory-installed battery is inadequate due to operation in extreme cold or due to extended use of multiple electrical accessories, your authorized dealer can assist. Your dealer can provide any installation procedures that may differ for an extreme use battery.

1. Ensure that the battery is fully charged.
2. Place the battery in the battery holder.
3. Coat the terminals with dielectric grease or petroleum jelly.
4. Secure the battery hold-down strap.

MAINTENANCE

5. Connect and tighten the red (positive) cable first.
6. Connect and tighten the black (negative) cable last.
7. Verify that cables are properly routed. Cables should be safely tucked away at the front and rear of the battery.
8. Close and secure the front box and cover.

BATTERY STORAGE

Whenever the vehicle is not used for a period of three months or more, remove the battery from the vehicle, ensure that it's fully charged, and store it out of the sun in a cool, dry place. Check battery voltage each month during storage and recharge as needed to maintain a full charge.

POLARIS recommends maintaining battery charge by using a POLARIS Battery Tender charger or by charging about once a month to make up for normal self-discharge. Battery Tender can be left connected during the storage period, and will automatically charge the battery if the voltage drops below a pre-determined point. See the Polaris Products section for the part numbers.

BATTERY CHARGING

The following battery charging instructions apply only to the installation of a sealed battery. Read all instructions before proceeding with the installation of this battery.

The sealed battery is already filled with electrolyte and has been sealed and *fully charged* at the factory. *Never* pry the sealing strip off or add any other fluid to this battery.

The single most important thing about maintaining a sealed battery is to keep it fully charged. Since the battery is sealed and the sealing strip cannot be removed, you must use a voltmeter or multimeter to measure DC voltage.

WARNING

An overheated battery may explode, causing severe injury or death. Always watch charging times carefully. Stop charging if the battery becomes very warm to the touch. Allow it to cool before resuming charging.

For a refresh charge, follow all instructions carefully.

1. The battery should be disconnected from a load or charger for at least two hours before checking voltage. Check the battery voltage with a voltmeter or multimeter. A fully charged battery will register 12.6 V or higher.
2. If the voltage is less than 12.6 volts, recharge the battery at 1.2 amps or less until battery voltage is 12.6 or greater.
3. When using an automatic charger, refer to the charger manufacturer's instructions for recharging. When using a constant current charger, use the following guidelines via the table below.

BATTERY CHARGING (SEALED BATTERY)

Always verify battery condition before and 1-2 hours after the end of charging.

STATE OF CHARGE	VOLTAGE	ACTION	CHARGE TIME (USING CONSTANT CURRENT CHARGER @ STANDARD AMPS SPECIFIED ON TOP OF BATTERY)
100%	12.6-12.8 volts	Conventional/Low Maintenance Battery: check after 60 days AGM Battery: check after 30 days	None required
50%-75%	12.0-12.5 volts	Needs charge	5-11 hours
25%-50%	11.5-12.0 volts	Needs charge	At least 13 hours, verify state of charge
0%-25%	11.5 volts or less	AGM ONLY: needs charge with desulfating charger	At least 20 hours

BATTERY IDENTIFICATION

IMPORTANT

It is important to identify the type of battery installed in the vehicle. Different types of batteries require different service procedures. Proper servicing and upkeep of the battery is very important for maintaining long battery life. All Polaris ORV models include either a Conventional battery or a Low Maintenance battery.

MAINTENANCE

CONVENTIONAL BATTERY

- The battery is NOT activated when packaged
- Distilled water and electrolyte added as required
- Removable cap plugs located on top of battery
- Vent tube located on side of battery

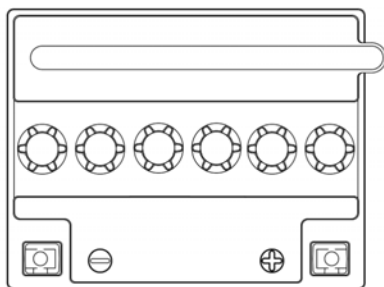

LOW MAINTENANCE BATTERY

- Battery activated when packaged
- Distilled water and electrolyte NEVER added
- Non removable cap(s) located on top of battery

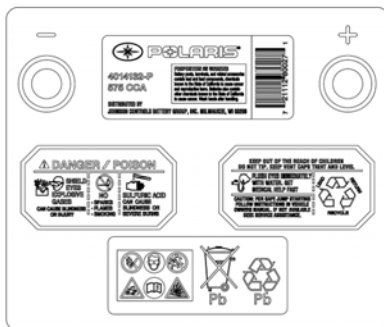

LEAD ACID CONVENTIONAL / DRY SHIPPED AGM BATTERY BEST PRACTICES

Some Polaris ORV models include either a Lead Acid Conventional battery or a Dry Shipped Absorbed Glass Mat (AGM) battery. See the Service Manual for procedures on how to activate, charge, maintain, and test a Lead Acid Conventional or Dry Shipped AGM battery.

NOTICE

Using a new battery that has not been fully charged can damage the battery and result in a shorter life. It can also hinder vehicle performance.

LEAD ACID CONVENTIONAL BATTERIES

ACTIVATION

NOTE
A Polaris battery purchased from a Polaris dealership should be activated at time of purchase by the dealer.

- Do NOT activate the battery unless it will be put into regular service within 30 days. Bulk acid should be used to activate the battery.
- Always remove the sealing cap from the vent elbow before activating the battery. Never put the sealing cap back onto the battery. The gas pressure can cause the battery to rupture.
- Let the battery sit for 30 minutes after you add the initial electrolyte. Once absorbed, fill the battery with additional electrolyte to the upper line of the electrolyte level indicator. This is the only time that electrolyte should be added to the battery.
- Once the battery is fully charged, replace cap plugs by hand. Do NOT use a tool to install the cap plugs.

CHARGING

- The battery must be fully charged before use or battery life will be significantly reduced by 10-30% of the battery's full potential.
- Nominal voltage is 12.6 to 12.8 Volts when fully charged. If the voltage falls below 12.5V, charge it immediately, or the battery service life and vehicle performance may be affected.
- Polaris recommends using a BatteryMINDER® 12V 1.5 AMP Convertible (**PN 2830511**) charger (or a similar charger), which can be ordered through your normal parts channel.
- Charge the battery with a charging output no larger than 10% of the battery's amp-hour rating.

MAINTENANCE

- Recharge the battery to its full capacity every 30 to 60 days.
- If the battery is stored or used in a partially charged condition, battery service life and vehicle performance may be adversely affected.
- Never add any electrolyte to the battery once the battery is in service. After the battery is initially activated, only distilled water should be added to maintain electrolyte levels.
- Store the battery in the vehicle with the cables disconnected, or store the battery in a cool / dry location. Batteries will self discharge more rapidly when stored in extreme temperatures.

MAINTENANCE

TESTING

- If the test fails, fully charge the battery.
- Proper load testing of the battery requires special equipment and can be performed by your dealer.

DRY SHIPPED AGM BATTERIES

ACTIVATION

- Do NOT activate the battery unless it will be put into regular service within 30 days. Only use the electrolyte container supplied with the battery to activate the battery.
- Keep the electrolyte container in place for 20 minutes or longer until the container is completely empty. If necessary, gently tap the container to empty it.
- Once the battery is fully charged, replace the strip of caps by hand. Do NOT use a tool to install the strip.

CHARGING

- Polaris recommends using a BatteryMINDER® 2012 AGM - 2 AMP (**PN 2830438**) charger, which can be ordered through your normal parts channel.
- Nominal voltage is 12.8 Volts when fully charged. If the voltage falls below 12.5V, charge it immediately, or the battery runs the risk of sulfation.

MAINTENANCE

- Never add any electrolyte or distilled water to the battery once the battery is in service.
- If you do not drive the vehicle for more than TWO weeks, maintain the battery with the BatteryMINDER® 2012 AGM - 2 AMP (**PN 2830438**) charger.
- If you plan to store the vehicle for ONE month or longer, remove the battery from the vehicle and store the battery in a cool / dry location. Continue to maintain the battery with the BatteryMINDER® 2012 AGM - 2 AMP (**PN 2830438**) charger and inspect the battery every 60 days.

TESTING

- If the test fails, fully charge the battery.
- If the battery is too low to accept a charge, see the AGM Battery Charging - Deeply Discharged (Below 3 Volts) procedure in the Service Manual.
- Proper load testing of the battery requires special equipment and can be performed by your dealer.

LOW MAINTENANCE BATTERY BEST PRACTICES

Some Polaris ORV models include either a Lead Acid or Absorbed Glass Mat (AGM) Low Maintenance battery. See the Service Manual for procedures on how to charge, maintain, and test a Lead Acid or AGM Low Maintenance battery.

NOTICE

Using a new battery that has not been fully charged can damage the battery and result in a shorter life. It can also hinder vehicle performance.

LEAD ACID LOW MAINTENANCE BATTERY

CHARGING

- The battery must be fully charged before use or battery life will be significantly reduced by 10-30% of the battery's full potential.
- Nominal voltage is 12.6 to 12.8 Volts when fully charged. If the voltage falls below 12.5V, charge it immediately, or the battery service life and vehicle performance may be affected.
- Polaris recommends using a BatteryMINDER® 12V 1.5 AMP Convertible (**PN 2830511**) charger (or a similar charger), which can be ordered through your normal parts channel.
- Charge the battery with a charging output no larger than 10% of the battery's amp-hour rating.

MAINTENANCE

- Recharge the battery to its full capacity every 30 to 60 days.
- If the battery is stored or used in a partially charged condition, hard crystal sulfation will form on the plates, reducing the efficiency and service life of the battery.
- Never add electrolyte or distilled water to the battery. Doing so will damage the case and shorten the life of the battery.
- Store the battery in the vehicle with the cables disconnected, or store the battery in a cool / dry location. Batteries will self discharge more rapidly when stored in extreme temperatures.

TESTING

- Test the battery using the PU-50296 battery tester.
- Proper load testing of the battery requires special equipment and can be performed by your dealer.

MAINTENANCE

AGM LOW MAINTENANCE BATTERIES

CHARGING

- Polaris recommends using a BatteryMINDer® 2012 AGM - 2 AMP (**PN 2830438**) charger, which can be ordered through your normal parts channel.
- Nominal voltage is 12.6–12.8 Volts when fully charged. If the voltage falls below 12.5V, charge it immediately, or the battery runs the risk of sulfation.

MAINTENANCE

- Never add electrolyte or distilled water to the battery. Doing so will damage the case and shorten the life of the battery.
- If you do not drive the vehicle for more than TWO weeks, maintain the battery with the BatteryMINDer® 2012 AGM - 2 AMP (**PN 2830438**) charger.
- If you plan to store the vehicle for ONE month or longer, remove the battery from the vehicle and store the battery in a cool / dry location. Continue to maintain the battery with the BatteryMINDer® 2012 AGM - 2 AMP (**PN 2830438**) charger and inspect the battery every 60 days.

TESTING

- If the test fails, fully charge the battery.
- If the battery is too low to accept a charge, see the AGM Battery Charging - Deeply Discharged (Below 3 Volts) procedure in the Service Manual.
- Proper load testing of the battery requires special equipment and can be performed by your dealer.

SUSPENSION ADJUSTMENT

FRONT/REAR SPRING PRELOAD ADJUSTMENT

The factory setting is appropriate for nearly all riding conditions. If desired, the suspension may be adjusted to maintain vehicle clearance height when carrying loads.

To adjust the preload, do the following:

1. Elevate the vehicle to allow the suspension to fully extend.
2. Turn the adjusting ring to the left to increase preload for a higher ride height. Turn the adjusting ring to the right to decrease preload for a lower ride height.

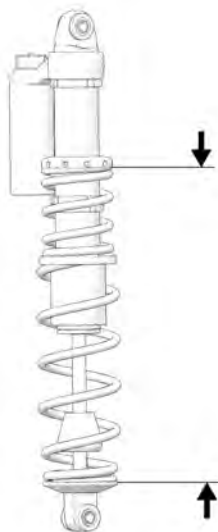

FACTORY PRELOAD SETTINGS		
Scrambler XP 1000 S	Front Suspension	15.63 in. (39.7 cm)
	Rear Suspension	15.56 in. (39.5 cm)

Follow these guidelines if you make adjustments to this suspension.

- Always return the suspension to the factory setting after the load is removed from the vehicle. The increased suspension height will negatively impact vehicle stability when operating without a load.
- Always apply the same adjustment setting to both sides of the vehicle.
- Do not increase the spring preload by more than one inch (25.4 mm) over the factory setting.
- When decreasing preload, make sure at least two turns of preload are holding the spring between the retainer on the top of the shock and the threaded spring preload adjuster nut on the shock body. Failure to do so could cause the retainer to fall off when the suspension is fully extended.

MAINTENANCE

CROSSOVER RING ADJUSTMENT

To adjust the preload, do the following:

1. Elevate the vehicle to allow the suspension to fully extend.
2. Using the spanner tool included with the vehicle, unlock the cross-over adjustment ring.
3. Adjust cross-over ring to desired location.
4. Lock the cross-over adjustment ring.

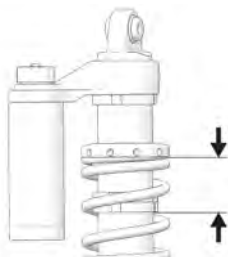

CROSSOVER RING FACTORY SETTINGS

Front Suspension	2 in. (5 cm)
------------------	--------------

HIGH/LOW SPEED COMPRESSION ADJUSTMENT

NOTICE

Always adjust the clicker at least one click below full stiff (full clockwise) or shock damage will occur.

HIGH SPEED COMPRESSION (RED)

To adjust high speed compression dampening, do the following:

1. Turn the outside clicker ① clockwise to increase compression damping.
2. To decrease high speed compression damping, turn the outside clicker counter-clockwise.

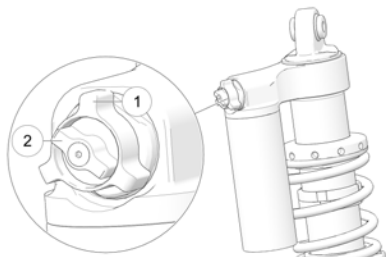

LOW SPEED COMPRESSION (BLACK)

To adjust high speed compression dampening, do the following:

1. Turn the inside clicker ② clockwise to increase compression damping.
2. To decrease high speed compression damping, turn the inside clicker counter-clockwise.

FACTORY CLICKER SETTINGS

Front/Rear High-Speed Suspension	8 Clicks from full Stiff
Front/Rear Low-Speed Suspension	5 Clicks from full Stiff

REBOUND DAMPING ADJUSTMENT

Increase the rebound damping force by turning the adjuster clockwise to increase the stiffness. Decrease the rebound damping force by turning the adjuster counterclockwise to increase the softness. The maximum adjustment for this adjuster is the fully turned in position. The minimum adjustment is 9 clicks out from the maximum position.

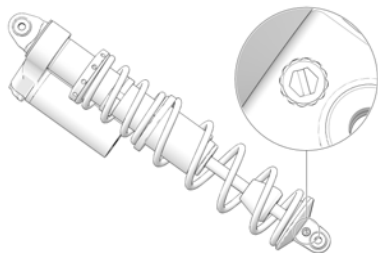

FACTORY CLICKER SETTINGS

Rebound Adjuster	5 Clicks from Full Stiff
------------------	--------------------------

THROTTLE BODY/IDLE RPM

Idle RPM is preset by the manufacturer. If the engine idle speed is not satisfactory, please see your POLARIS dealer or other qualified service facility for adjustment.

HANDLEBARS

The handlebars can be adjusted for rider preference.

⚠ WARNING

Improper adjustment of the handlebars or incorrect torquing of the adjuster block tightening bolts can cause limited steering or loosening of the handlebars, resulting in loss of control and serious injury or death. Follow the adjustment procedures exactly, or see your POLARIS dealer for service.

MAINTENANCE

1. Remove the upper headlight pod.
2. Loosen the four handlebar bolts.
3. Adjust the handlebar to the desired height. Be sure the handlebars do not contact the gas tank or any other part of the machine when turned fully to the left or right.
4. Torque the front two bolts to specification, then torque the rear two bolts. A gap of up to 1/8" (3 mm) will remain at the rear of the clamp blocks.

TORQUE

Handlebar Bolts:
20 ft-lbs (27 N·m)

5. Reinstall the headlight pod.

NOTICE

Test for full, free range of motion by turning the handlebars side to side.

CLEANING AND STORAGE

WASHING THE VEHICLE

Keeping your POLARIS vehicle clean will not only improve its appearance but it can also extend the life of various components.

Water in the PVT system could cause the drive belt to become wet and slip in the clutches. Always avoid spraying water directly toward any intake pre-filters. If water does enter the PVT intake, follow the procedure in the PVT Drying section.

Certain products, including insect repellents and chemicals, will damage plastic surfaces. Do not allow these types of products to contact the vehicle.

The best way to clean your POLARIS vehicle is with a garden hose and a pail of mild soap and water.

1. Use a professional-type washing cloth, cleaning the upper body first and the lower parts last.
2. Rinse with clean water frequently.
3. Dry surfaces with a chamois to prevent water spots.

WASHING TIPS

- Avoid the use of harsh cleaners, which can damage the finish.
- Do not use medium to heavy duty compounds on the finish.
- Always use clean cloths and pads for cleaning and polishing. Old or reused cloths and pads may contain dirt particles that will scratch the finish.
- Do not use high-speed polishers/buffers on body panels, as damage or color fading may occur.

USING A HIGH PRESSURE WATER SYSTEM

 **WARNING**

Spilled oil left on engine components or in the engine area may pose a fire hazard. Use shop rags to clean any spilled oil. If needed, use a non-flammable solvent on the rag to aid in the cleaning process. Do not use any device such as pressurized water or air as this may disperse the oil onto the engine components and could pose a fire hazard.

MAINTENANCE

If a high pressure water system is used for cleaning, exercise extreme caution. The maximum pressure should not exceed 3000 psi (20684.27 kPa), 2.5 GPM (567.81 LPH) with a 40° pressure washer nozzle. Make sure to keep the pressure washer nozzle 2 ft (60 cm) from the vehicle and away from the surface being cleaned. High water pressure could remove paint and labels and damage radiator fins and/or impair a radiator's effectiveness. High water pressure with a hot temperature could also damage brake lines with the nozzle at a close proximity even with a short exposure time. Avoid directing the water stream at the following items:

- Wheel bearings
- Radiator
- Transmission seals
- Brakes / brake lines
- Body panels
- Labels and decals
- Electrical components and wiring
- Air intake components
- Throttle and shift cables and controls
- Seats

If warning and safety labels are damaged, contact your POLARIS dealer for free replacement.

Grease all zerk fittings immediately after washing. Allow the engine to run for a while to evaporate any water that may have entered the engine or exhaust system.

POLISHING THE VEHICLE

POLARIS recommends the use of common household aerosol furniture polish for polishing the finish on your POLARIS vehicle. Follow the instructions on the container.

POLISHING TIPS

- Avoid the use of automotive products, some of which can scratch the finish of your vehicle.
- Always use clean cloths and pads for cleaning and polishing. Old or reused cloths and pads may contain dirt particles that will scratch the finish.

STORAGE TIPS

NOTICE

Starting the engine during the storage period will disturb the protective film created by fogging and damage could occur. Never start the engine during the storage period.

CLEAN THE EXTERIOR

Make any necessary repairs and clean the vehicle as recommended. See the Washing the Vehicle section.

STABILIZE THE FUEL

1. Fill the fuel tank.
2. Add POLARIS Carbon Clean Fuel Treatment or POLARIS Fuel Stabilizer or equivalent fuel treatments or stabilizers. Follow the instructions on the container for the recommended amount. Carbon Clean removes water from fuel systems, stabilizes fuel and removes carbon deposits from pistons, rings, valves and exhaust systems.
3. Allow the engine to run for 15-20 minutes to allow the stabilizer to disperse through the entire fuel delivery system.

OIL AND FILTER

Change the oil and filter. See the Engine Oil section.

AIR FILTER / AIR BOX

Replace the air filter. See Maintenance Chapter. Clean the air box.

FLUID LEVELS

Inspect the fluid levels. Add or change fluids as recommended in the Periodic Maintenance Chart.

- Demand drive fluid (front gearcase)
- Rear gearcase fluid (if equipped)
- Transmission fluid
- Brake fluid (change every two years and any time the fluid looks dark or contaminated)
- Coolant (test strength/fill)

INSPECT AND LUBRICATE

Inspect all cables and lubricate all areas of the vehicle as recommended in the Periodic Maintenance Chart.

FOG THE ENGINE

1. Treat the fuel system with POLARIS Carbon Clean or other equivalent fuel treatment. Follow the instructions on the container. Start the engine. Allow it to idle for several minutes so the Carbon Clean reaches the injectors. Stop the engine.
2. Remove the spark plugs and add 1–1.5 oz. (29.5–44 cc.) of engine oil. To access the plug holes, use a section of clear 6 mm (1/4") hose and a small plastic squeeze bottle filled with the pre-measured amount of oil. *Do this carefully! If you miss the plug holes, oil will drain from the spark plug cavities into the hole at the front of the cylinder head, and appear to be an oil leak.*
3. Reinstall the spark plugs. Torque to specification.

MAINTENANCE

4. Apply dielectric grease to the inside of each spark plug cap. *Do not reinstall the cap onto the plug at this step.*
5. Turn the engine over several times. Oil will be forced in and around the piston rings and ring lands, coating the cylinder with a protective film of fresh oil.
6. Reinstall the spark plug caps.
7. If POLARIS fuel system additive is not used, fuel tank, fuel lines, and injectors should be completely drained of gasoline.

BATTERY MAINTENANCE

See the **Battery Storage and Battery Charging** sections for storage and charging procedures.

STORAGE AREA / COVERS

Be sure the storage area is well ventilated. Cover the vehicle with a genuine POLARIS cover. Do not use plastic or coated materials. They do not allow enough ventilation to prevent condensation, and may promote corrosion and oxidation.

TRANSPORTING THE ATV

Follow these procedures when transporting the vehicle.

1. Stop the engine.
2. Place the transmission in PARK.
3. Lock the parking brake.
4. Secure the fuel cap, oil cap and seats.
5. Always tie the frame of the ATV to the transporting unit securely with suitable straps or rope. Do not attach tie straps to the front A- arm bolt pockets, racks or handlebars.
6. Remove the key to prevent loss during transporting.

SPECIFICATIONS

SCRAMBLER XP 1000 S

SCRAMBLER XP 1000 S	
Maximum Weight Capacity	290 lb (131 kg) (includes operator, cargo and accessories)
Dry Weight	881 lb (400 kg)
Fuel Capacity	5.25 gal (20 L)
Engine Oil Capacity	2 qt (1.9 L)
Coolant Capacity	3 qt (2.8 L)
Rear Gearcase Oil Capacity	7.1 oz (210 mL)
Demand Drive Fluid Capacity	9.3 oz (275 mL)
Transmission Oil Capacity	37 oz (1100 mL)
Front Rack Capacity	25 lb (11.3 kg)
Rear Rack Capacity	50 lb (22.7 kg)
Receiver Hitch Tongue Capacity	150 lb (68 kg) Rear rack capacity and tongue weight not to exceed 240 lb (109 kg)
Hitch Towing Rating	1500 lb (680.4 kg)
Unbraked Trailer Towing Capacity	1914 lb (868 kg)
Overall Length	90 in (228 cm)
Overall Width	55 in (139.7 cm)
Overall Height	48 in (121.9 cm)
Wheelbase	53 in (134.6 cm)
Ground Clearance	10.6 in (27 cm)
Minimum Turning Radius	84 in (213 cm) unloaded
Engine	EHO952LE
Displacement	952 cc
Bore x Stroke	90.5 x 74
Alternator Output	475w @1200 RPM/Peak 630w
Compression Ratio	11:1

SPECIFICATIONS

SCRAMBLER XP 1000 S	
Starting System	Electric
Ignition System	Electronic Fuel Injection
Ignition Timing	6° +/- 5° BTDC @ 1200 RPM, Engine warm
Idle RPM	1200 +/- 50
Throttle Body / Size	MIKUNI® Dual Bore / 42 mm
Spark Plug Type / Gap	AUTOLITE® 5682 / .030 in (0.76 mm)
Lubrication System	Wet Sump
Driving System Type	Automatic PVT (POLARIS Variable Transmission)
Front Suspension	Dual A-Arm with 9.2 in (23 cm) travel
Rear Suspension	Progressive rate with 10.2 in (26 cm) travel
Transmission	H/L/N/R/P
Gear Reduction, Low	5.034:1
Gear Reduction, Reverse	4.508:1
Gear Reduction, High	2.367:1
Drive Ratio, Front	3.818:1
Drive Ratio, Rear	3.7:1
Tires / Pressure, Front	27x9-12 / 7 psi (48.3 kPa)
Tires / Pressure, Rear	27x9-12 / 7 psi (48.3 kPa)
Brakes, Front / Rear	Single-Control Hydraulic Disc, All Wheel
Brakes, Auxiliary	Foot-Activated Hydraulic Disc, Rear Wheel
Brake, Parking	Hydraulic Lock, All Wheel
Headlight	Hi / Lo Beam on Bumper (50 watt)
Taillights	LED
Instrument Cluster	Digital

SCRAMBLER XP 1000 S CLUTCHING

CLUTCH SETTINGS					
Altitude		Shift Weight	Drive Spring	Driven Spring	Helix
Meters (Feet)	0-1800 (0-6000)	23-64 1323575	42-140 Purple 7043805	Black 140-240 7045111	62SR PT 3236444
	1800+ (6000+)	23-60 5142260			

POLARIS PRODUCTS

LUBRICANTS / SERVICE PRODUCTS

PRODUCT	SIZE	PART NUMBER
Fogging Oil	12 oz (340 g) aerosol	2870791
PS-4	1 qt (0.95 L)	2876244
	1 gal (3.8 L)	2876245
PS-4 Extreme Duty	1 qt (0.95 L)	2889395
	1 gal (3.8 L)	2889396
Oil Change Kit	Includes 2 qt of PS-4 engine oil, 1 oil filter, and 1 drain plug washer	2877473
AGL	1 qt (0.95 L)	2878068
	1 gal (3.8 L)	2878069
Pump for Gallon Jug	—	2870465
Demand Drive Fluid	1 qt (0.95 L)	2877922
Angle Drive Fluid	1 qt (0.95 L)	2889280
Antifreeze / Coolant	1 qt (0.95 L)	2880514
	1 gal (3.8 L)	2880513
Grease Gun Kit, Premium All Season	—	2871312
All Season Grease	4-pack 3 oz (85.05 g) cartridge	2871322
	14 oz (396.9 g) cartridge	2871423
U-Joint Grease	3 oz (85.05 g) cartridge	2871515
	14 oz (396.9 g) cartridge	2871551
Carbon Clean	12 fl oz (355 mL)	2881413
Fuel Stabilizer	12 fl oz (355 mL)	2881416
DOT 4 Brake Fluid	12 fl oz (355 mL)	2872189
BatteryMINDER® 2012 AGM - 2 AMP Charger	—	2830438

TROUBLESHOOTING

DIAGNOSTIC DISPLAY CODE DEFINITIONS

Open Load: There is a break in the wires that lead to the item listed in the chart (injector, fuel pump, etc.), or the item has failed.

Short-to-Ground: The wire is shorted to ground between the electronic control unit and the item listed in the chart.

Shorted Load: The wires leading to the item listed in the chart are shorted together, or the item has shorted internally.

Short-to-Battery: The wire leading from the item listed in the chart to the electronic control unit is shorted to a wire at battery voltage.

DIAGNOSTIC CODES			
COMPONENT	CONDITION	SPN	FMI
Throttle Position Sensor	Voltage Too High	51	3
	Voltage Too Low	51	4
Engine Temperature Sensor	Voltage Too High	110	3
	Voltage Too Low	110	4
	Temperature Too High	110	16
	Engine Overheat Shutdown	110	0
Intake Air Temperature Sensor	Voltage Too High	105	3
	Voltage Too Low	105	4
Manifold Absolute Pressure Sensor	Voltage Too High	102	3
	Voltage Too Low	102	4
	Signal Out of Range	102	2
Crankshaft Position Sensor	Circuit Fault	636	8
	Plausibility Fault	636	2
Vehicle Speed Signal	Speed Too High	84	8
	Plausibility Fault	84	2
Gear Sensor Signal	Voltage Too Low	523	4
	Voltage Too High	523	3

TROUBLESHOOTING

DIAGNOSTIC CODES			
COMPONENT	CONDITION	SPN	FMI
	Signal Fault	523	2
Injector 1 (MAG) (SDI Part Load)	Driver Circuit Open/Grounded	651	5
	Driver Circuit Short to B+	651	3
	Driver Circuit Grounded	651	4
Injector 2 (PTO) (SDI Part Load)	Driver Circuit Open/Grounded	652	5
	Driver Circuit Short to B+	652	3
	Driver Circuit Grounded	652	4
Ignition Coil Primary Driver 1 (MAG)	Driver Circuit Short to B+	1268	3
Ignition Coil Primary Driver 2 (PTO)	Driver Circuit Short to B+	1269	3
Fuel Pump Driver Circuit	Driver Circuit Open/Grounded	1347	5
	Driver Circuit Short to B+	1347	3
	Driver Circuit Grounded	1347	4
Fan Relay Driver Circuit	Driver Circuit Open/Grounded	1071	5
	Driver Circuit Short to B+	1071	3
	Driver Circuit Grounded	1071	4
Idle Air Control	Driver Circuit Open/Grounded	634	5
	Driver Circuit Short to B+	634	3
	Driver Circuit Grounded	634	4
	Position Out of Range	634	7

TROUBLESHOOTING

DIAGNOSTIC CODES			
COMPONENT	CONDITION	SPN	FMI
Starter Enable Circuit	Driver Circuit Open/Grounded	1321	5
	Driver Circuit Short to B+	1321	3
	Driver Circuit Grounded	1321	4
Chassis Relay	Driver Circuit Open/Grounded	520208	5
	Driver Circuit Short to B+	520208	3
	Driver Circuit Grounded	520208	4
All Wheel Drive Control	Driver Circuit Open/Grounded	520207	5
	Driver Circuit Short to B+	520207	3
	Driver Circuit Grounded	520207	4
System Power	Voltage Too High	168	3
	Voltage Too Low	168	4
Throttle Safety Signal	Voltage Too High	520194	3
	Voltage Too Low	520194	4
	Signal Out of Range	520194	2
	Throttle Stuck	520194	7
Active Descent Control System	Driver Circuit Open/Grounded	520203	5
	Driver Circuit Short to B+	520203	3
	Driver Circuit Grounded	520203	4
Idle Speed	Speed Too High	520211	3
	Speed Too Low	520211	4
Right Hand Control	Momentary Driveline Mode Switch Press	520468	31

TROUBLESHOOTING

DIAGNOSTIC CODES			
COMPONENT	CONDITION	SPN	FMI
EPS MODELS ONLY			
Vehicle Speed Sensor	Data Valid But Above Normal Operational Range - Most Severe Level	84	0
	Data Erratic, Intermittent Or Incorrect	84	2
	Abnormal Rate Of Change	84	10
	Received Network Data In Error	84	19
System Power	Data Valid But Above Normal Operational Range - Most Severe Level	168	0
	Voltage Above Normal, Or Shorted To High Source	168	3
	Voltage Below Normal, Or Shorted To Low Source	168	4
Engine Speed	Data Valid But Above Normal Operational Range - Most Severe Level	190	0
	Data Erratic, Intermittent Or Incorrect	190	2
	Received Network Data In Error	190	19
ECU Memory	Bad Intelligent Device Or Component	628	12
	Out Of Calibration	628	13
Calibration	Out Of Calibration	630	13
Steering Over Current Shut Down	Current Above Normal Or Grounded Circuit	520221	6
Steering Excessive Current Error	Current Above Normal Or Grounded Circuit	520222	6

TROUBLESHOOTING

DIAGNOSTIC CODES			
COMPONENT	CONDITION	SPN	FMI
EPS MODELS ONLY			
Steering Torque Partial Failure	Condition Exists	520223	31
Steering Torque Full Failure	Condition Exists	520224	31
EPAS Inverter Temperature	Data Valid But Above Normal Operational Range - Most Severe Level	520225	0
	Data Valid But Above Normal Operating Range - Moderately Severe Level	520225	16
EPAS Communications Receive Data Error	Data Erratic, Intermittent Or Incorrect	520226	2
	Condition Exists	520226	31
Position Encoder Error	Root Cause Not Known	520228	11
	Bad Intelligent Device Or Component	520228	12
	Condition Exists	520228	31
EPAS Software Error	Bad Intelligent Device Or Component	520229	12
	Condition Exists	520229	31
EPAS Power Save Condition	Condition Exists	520231	31
EPS SEPIC Voltage Error	Voltage Above Normal, Or Shorted To High Source	524086	3
	Voltage Below Normal, Or Shorted To Low Source	524086	4

TROUBLESHOOTING

DRIVE BELT WEAR/BURN

POSSIBLE CAUSE	SOLUTION
Driving onto a pickup or tall trailer in high range	Use low range during loading.
Starting out going up a steep incline	Use low range.
Driving at low RPM or ground speed – 3–7 mph (4.8–11.3 km/h)	Drive at a higher speed or use low range more frequently.
Insufficient warm-up at low ambient temperatures	Warm the engine at least 5 minutes. With the transmission in neutral, advance the throttle to about 1/8 throttle in short bursts, 5 to 7 times. The belt will become more flexible and prevent belt burning.
Slow/easy clutch engagement	Use the throttle quickly and effectively.
Towing/pushing at low RPM/low ground speed	Use low range only.
Utility use/plowing	Use low range only.
Stuck in mud or snow	Shift the transmission to low range and carefully use fast, aggressive throttle application to engage clutch. WARNING: Excessive throttle may cause loss of control and vehicle rollover.
Climbing over large objects from a stopped position	Shift the transmission to low range and carefully use fast, brief, aggressive throttle application to engage clutch. WARNING: Excessive throttle may cause loss of control and vehicle rollover.
Belt slippage from water or snow ingestion into the PVT system	Dry out the PVT. Prevent water from entering the PVT intake duct. See Intake Pre-Filters for more information. Inspect clutch seals for damage if repeated leaking occurs.
Clutch malfunction	An authorized dealer can assist.
Poor engine performance	Check for clogged air filter, clogged fuel filter, water in the fuel or foreign material in fuel tank or fuel lines. An authorized dealer can assist.
Slippage from failure to warm up belt	Always warm up the belt by operating below 30 mph (48 km/h) for 1 miles (1.6 km) (5 miles (8 km) or more when temperature is below freezing).
Wrong or missing belt	Install the recommended belt.
Improper break-in	Always break in a new belt and/or clutch.

ENGINE DOESN'T TURN OVER

POSSIBLE CAUSE	SOLUTION
Low battery voltage	Recharge the battery.
Loose battery connections	Check all connections and tighten.
Loose solenoid connections	Check all connections and tighten.
Loose electronic control box connections	Inspect, clean, reinstall connectors.

ENGINE TURNS OVER, FAILS TO START

POSSIBLE CAUSE	SOLUTION
Out of fuel	Refuel.
Water is present in fuel	Drain the fuel system and refuel.
Old or non-recommended fuel	Replace with fresh recommended fuel.
Fouled or defective spark plug	Inspect plug and replace if necessary.
No spark to spark plug	Inspect plug and replace if necessary.
Water or fuel in crankcase	Your authorized dealer can assist.
Low battery voltage	Recharge the battery to 12.8 VDC.
Mechanical failure	Your authorized dealer can assist.

ENGINE BACKFIRES

POSSIBLE CAUSE	SOLUTION
Weak spark from spark plug	Inspect, clean and/or replace spark plug
Incorrect spark plug gap or heat range	Set gap to specs or replace plug
Old or non-recommended fuel	Replace with fresh recommended fuel
Incorrectly installed spark plug wires	Your authorized dealer can assist

TROUBLESHOOTING

POSSIBLE CAUSE	SOLUTION
Mechanical failure	Your authorized dealer can assist
Loose ignition connections	Check all connections and tighten
Water present in fuel	Replace with fresh recommended fuel

ENGINE PINGS OR KNOCKS

POSSIBLE CAUSE	SOLUTION
Poor quality or low octane fuel	Replace with recommended fuel
Incorrect spark plug gap or heat range	Set gap to specs or replace plug

ENGINE RUNS IRREGULARLY, STALLS OR MISFIRES

POSSIBLE CAUSE	SOLUTION
Fouled or defective spark plug	Inspect, clean and/or replace spark plug
Worn or defective spark plug wires	Your authorized dealer can assist
Incorrect spark plug gap or heat range	Set gap to specs or replace plug
Loose ignition connections	Check all connections and tighten
Water present in fuel	Replace with new fuel
Low battery voltage	Recharge battery to 12.8 VDC
Incorrect fuel	Replace with recommended fuel
Clogged air filter	Inspect and clean or replace
Clogged intake pre-filter	Inspect and clean (with soapy water) or replace
Other mechanical failure	Your authorized dealer can assist

ENGINE STOPS OR LOSES POWER

POSSIBLE CAUSE	SOLUTION
Out of fuel	Refuel
Kinked or plugged fuel vent line	Inspect and replace
Water is present in fuel	Replace with new fuel

TROUBLESHOOTING

POSSIBLE CAUSE	SOLUTION
Fouled or defective spark plug	Inspect, clean and/or replace spark plug
Worn or defective spark plug wires	Your authorized dealer can assist
Incorrect spark plug gap or heat range	Set gap to specs or replace plug
Loose ignition connections	Check all connections and tighten
Low battery voltage	Recharge the battery
Incorrect fuel	Replace with fresh recommended fuel
Clogged air filter	Inspect and clean or replace
Clogged intake pre-filter	Inspect and clean (with soapy water) or replace
Other mechanical failure	Your authorized dealer can assist
Overheated engine	Clean radiator screen and core, clean engine exterior, and check coolant level. Your dealer can assist.

WARRANTY

LIMITED WARRANTY

POLARIS Industries Inc., 2100 Highway 55, Medina, MN 55340 (POLARIS) gives a SIX MONTH LIMITED WARRANTY on all components of your POLARIS vehicle against defects in material or workmanship. Laws and regulations in your jurisdiction may give extra protection. POLARIS further warrants that the spark arrester in this product will meet the efficiency requirements of USFS standard 5100-1C for at least 1000 hours when subjected to normal use and when maintenance and installation are in accordance with POLARIS recommendations.

This warranty covers parts and labor charges for repair or replacement of defective parts and begins on the date of purchase by the original retail purchaser. The duration of this warranty may vary by international region based upon local laws and regulations.

REGISTRATION

At the time of sale, the Warranty Registration Form must be completed by your dealer and submitted to POLARIS within ten days of purchase. Upon receipt of this registration, POLARIS will record the registration for warranty. No verification of registration will be sent to the purchaser as the copy of the Warranty Registration Form will be your proof of warranty coverage. If you have not signed the original registration and received the customer copy, please contact your dealer immediately. Initial dealer preparation and set-up of your vehicle is very important in ensuring trouble-free operation.

WARRANTY

WARRANTY COVERAGE AND EXCLUSIONS

LIMITATIONS OF WARRANTIES AND REMEDIES

This POLARIS limited warranty excludes any failures that are not caused by a defect in material or workmanship. THIS WARRANTY DOES NOT COVER CLAIMS OF DEFECTIVE DESIGN. This warranty also does not cover acts of God, accidental damage, normal wear and tear, abuse or improper handling. This warranty also does not cover damage to any vehicle, component, or part as a result of being structurally modified, neglected, improperly maintained or used for racing, competition or purposes other than for which it was designed.

This warranty excludes damages or failures resulting from improper lubrication; improper engine timing; improper fuel; surface imperfections caused by external stress, heat, cold or contamination; operator error or abuse; improper component alignment, tension, adjustment or altitude compensation; snow, water, dirt or other foreign substance ingestion/contamination; improper maintenance; modified components; use of aftermarket or unapproved components, accessories, or attachments; use of unapproved software or calibration; unauthorized repairs; or repairs made after the warranty period expires or by an unauthorized repair center.

This warranty excludes damages or failures caused by abuse, accident, fire, or any other cause other than a defect in materials or workmanship and provides no coverage for consumable components, general wear items, or any parts exposed to friction surfaces, stresses, environmental conditions and/or contamination for which they were not designed or not intended, including but not limited to the following items:

- Wheels and tires
- Suspension components
- Brake components
- Seat components
- Clutches and components
- Steering components
- Batteries
- Light bulbs/Sealed beam lamps
- Filters
- Lubricants
- Bushings
- Finished and unfinished surfaces
- Carburetor/Throttle body components
- Engine components
- Drive belts
- Hydraulic components and fluids
- Circuit breakers/Fuses
- Electronic components
- Spark plugs
- Sealants
- Coolants
- Bearings

LUBRICANTS AND FLUIDS

1. Mixing oil brands or using non-recommended oil may cause engine damage. We recommend the use of POLARIS engine oil.
2. Damage or failure resulting from the use of non-recommended lubricants or fluids is not covered by this warranty.

This warranty provides no coverage for personal loss or expense, including mileage, transportation costs, hotels, meals, shipping or handling fees, product pick-up or delivery, replacement rentals, loss of product use, loss of profits, or loss of vacation or personal time.

THE EXCLUSIVE REMEDY FOR BREACH OF THIS WARRANTY SHALL BE, AT POLARIS' OPTION, REPAIR OR REPLACEMENT OF ANY DEFECTIVE MATERIALS, COMPONENTS, OR PRODUCTS. THE REMEDIES SET FORTH IN THIS WARRANTY ARE THE ONLY REMEDIES AVAILABLE TO ANY PERSON FOR BREACH OF THIS WARRANTY. POLARIS SHALL HAVE NO LIABILITY TO ANY PERSON FOR INCIDENTAL, CONSEQUENTIAL OR SPECIAL DAMAGES OF ANY DESCRIPTION, WHETHER ARISING OUT OF EXPRESS OR IMPLIED WARRANTY OR ANY OTHER CONTRACT, NEGLIGENCE, OR OTHER TORT OR OTHERWISE. THIS EXCLUSION OF CONSEQUENTIAL, INCIDENTAL, AND SPECIAL DAMAGES IS INDEPENDENT FROM AND SHALL SURVIVE ANY FINDING THAT THE EXCLUSIVE REMEDY FAILED OF ITS ESSENTIAL PURPOSE.

THE IMPLIED WARRANTY OF FITNESS FOR A PARTICULAR PURPOSE IS EXCLUDED FROM THIS LIMITED WARRANTY. ALL OTHER IMPLIED WARRANTIES (INCLUDING BUT NOT LIMITED TO THE IMPLIED WARRANTY OF MERCHANTABILITY) ARE LIMITED IN DURATION TO THE ABOVE SIX MONTH WARRANTY PERIOD. POLARIS DISCLAIMS ALL EXPRESS WARRANTIES NOT STATED IN THIS WARRANTY. SOME STATES DO NOT PERMIT THE EXCLUSION OR LIMITATION OF INCIDENTAL OR CONSEQUENTIAL DAMAGES OR ALLOW LIMITATIONS ON THE DURATION OF IMPLIED WARRANTIES, SO THE ABOVE LIMITATIONS MAY NOT APPLY TO YOU IF INCONSISTENT WITH CONTROLLING STATE LAW.

HOW TO OBTAIN WARRANTY SERVICE

You are responsible for presenting your vehicle to an authorized POLARIS dealer as soon as a problem exists. The warranty repairs should be completed in a reasonable amount of time, not to exceed 30 days. However any damage caused to the product by you or any non-authorized third party may void this warranty. Warranty or Service Bulletin repairs must be done by an authorized POLARIS dealer, or other qualified person authorized by POLARIS.

Outside the Country where your product was purchased:

If you are traveling temporarily outside the country where your product was purchased, you should take your product to an authorized POLARIS dealer. You must show the dealer photo identification from the country of the selling dealer's authorized location as proof of residence. Upon residence verification, the servicing dealer will be authorized to perform the warranty repair.

If you move:

If you move to another country, be sure to contact POLARIS Owner Connections and the customs department of the destination country before you move. Product importation rules vary considerably from country to country. You may be required to present documentation of your move to POLARIS to continue your warranty coverage. You may also be required to obtain documentation from POLARIS to register your product in your new country. We recommend that you register your product at a local authorized POLARIS dealer promptly after you move.

If you purchase from a private party:

If you purchase a POLARIS product from a private party, to be kept and used outside of the country in which the product was originally purchased, all warranty coverage will be denied. However, we encourage you to promptly register your product at your local authorized POLARIS dealer to receive safety information and notice regarding your product.

EXPORTED PRODUCTS

EXCEPT WHERE SPECIFICALLY REQUIRED BY LAW, THERE IS NO WARRANTY OR SERVICE BULLETIN COVERAGE ON THIS PRODUCT IF IT IS SOLD OUTSIDE THE COUNTRY OF THE SELLING DEALER'S AUTHORIZED LOCATION. This policy does not apply to products that have received authorization for export from POLARIS. Dealers may not give authorization for export. You should consult an authorized dealer to determine this product's warranty or service coverage if you have any questions. This policy does not apply to products registered to government officials or military personnel on assignment outside the country of the selling dealer's authorized location. This policy does not apply to Safety Bulletins.

NOTICE

If your product is registered outside of the country where it was purchased and you have not followed the procedure set above, your product will no longer be eligible for warranty or service bulletin coverage of any kind, other than safety bulletins. Products registered to government officials or military personnel on assignment outside of the country where the product was purchased will continue to be covered by the Limited Warranty.

Please work with your dealer to resolve any warranty issues. Dealership contacts can be found via this website, if needed:

www.polaris.com/en-us/contact

Should your dealer require any additional assistance, they will contact the appropriate person at POLARIS.

This warranty gives you specific legal rights, and you may also have other rights which vary from state to state or in different countries. If any of the above terms are void because of federal, state, local law, all other warranty terms will remain in effect.

For questions call POLARIS Owner Connections:

United States & Canada: 1-800-POLARIS (1-800-765-2747)

WARRANTY

U.S.A. EPA EMISSIONS LIMITED WARRANTY

This emissions limited warranty is in addition to the POLARIS standard limited warranty for your vehicle. POLARIS Industries Inc. warrants that at the time it is first purchased, this emissions-certified vehicle is designed, built and equipped so it conforms with applicable U.S. Environmental Protection Agency emission regulations. POLARIS warrants that the vehicle is free from defects in materials and workmanship that would cause it to fail to meet these regulations.

The warranty period for off road vehicles 100cc or greater emissions-certified vehicles starts on the date of purchase by original retail purchaser and continues for a period of 500 hours of engine operation, 3100 miles (5000 km) of vehicle travel, or 30 calendar months from the date of purchase, whichever comes first. The warranty period for ATVs less than 100cc emissions-certified vehicles starts on the date of purchase by original retail purchaser and continues for a period of 250 hours of engine operation, 1550 miles (2500 km) of vehicle travel, or 30 calendar months from the date of purchase, whichever comes first. This EPA emissions warranty period is extended for at least as long as the standard factory warranty that POLARIS provides on the vehicle as a whole. The EPA emissions warranty period does not further extend if you purchase additional warranty coverage in the form of a service contract or other paid warranty extension, but emission-related parts may be covered subject to the terms of any such paid service contract or paid warranty extension.

This emissions limited warranty covers components whose failure increases the vehicle's regulated emissions, and it covers components of systems whose only purpose is to control emissions. Repairing or replacing other components not covered by this warranty is the responsibility of the vehicle owner. This emissions limited warranty does not cover components whose failure does not increase the vehicle's regulated emissions.

For exhaust emissions, emission-related components include any engine parts related to the following systems:

- Air-induction system
- Fuel system
- Ignition system
- Exhaust gas recirculation systems

The following parts are also considered emission-related components for exhaust emissions:

- After treatment devices
- Crankcase ventilation valves
- Sensors
- Electronic control units

The following parts are considered emission-related components for evaporative emissions:

- Fuel Tank
- Fuel Cap
- Fuel Line
- Fuel Line Fittings
- Clamps*
- Pressure Relief Valves*
- Control Valves*
- Control Solenoids*
- Electronic Controls*
- Vacuum Control Diaphragms*
- Control Cables*
- Control Linkages*
- Purge Valves
- Vapor Hoses
- Liquid/Vapor Separator
- Carbon Canister
- Canister Mounting Brackets
- Carburetor Purge Port Connector

*As related to the evaporative emission control system.

Emission-related components also include any other part whose only purpose is to reduce emissions or whose failure will increase emissions without significantly degrading engine/equipment performance. The exclusive remedy for breach of this limited warranty shall be, at the exclusive option of POLARIS, repair or replacement of any defective materials, components or products. THE REMEDIES SET FORTH IN THIS LIMITED WARRANTY ARE THE ONLY REMEDIES AVAILABLE TO ANY PERSON FOR BREACH OF THIS WARRANTY. POLARIS SHALL HAVE NO LIABILITY TO ANY PERSON FOR INCIDENTAL, CONSEQUENTIAL OR SPECIAL DAMAGES OF ANY DESCRIPTION, WHETHER ARISING OUT OF EXPRESS OR IMPLIED WARRANTY OR ANY OTHER CONTRACT, NEGLIGENCE OR OTHER TORT OR OTHERWISE. THIS EXCLUSION OF CONSEQUENTIAL, INCIDENTAL, AND SPECIAL DAMAGES IS INDEPENDENT FROM AND SHALL SURVIVE ANY FINDING THAT THE EXCLUSIVE REMEDY FAILED OF ITS ESSENTIAL PURPOSE.

ALL IMPLIED WARRANTIES (INCLUDING BUT NOT LIMITED TO ANY IMPLIED WARRANTIES OF MERCHANTABILITY AND FITNESS FOR A PARTICULAR PURPOSE) ARE LIMITED IN DURATION TO THE WARRANTY PERIOD DESCRIBED HEREIN. POLARIS DISCLAIMS ALL EXPRESS WARRANTIES NOT STATED IN THIS WARRANTY. Some states do not allow limitations on how long an implied warranty lasts, so the above limitation may not apply if it is inconsistent with the controlling state law.

This limited warranty excludes failures not caused by a defect in material or workmanship. This limited warranty does not cover damage due to accidents, abuse or improper handling, maintenance or use. This limited warranty also does not cover damage to any engine as a result of being structurally altered, or when the vehicle has been used in racing competition. This limited warranty also does not cover physical damage, corrosion or defects caused by fire, explosions or other similar causes beyond the control of POLARIS.

WARRANTY

Owners are responsible for performing the scheduled maintenance identified in the owner's manual. POLARIS may deny warranty claims for failures that have been caused by the owner's or operator's improper maintenance or use, by accidents for which POLARIS has no responsibility, or by acts of God.

Any qualified repair shop or person may maintain, replace, or repair the emission control devices or systems on your vehicle. An authorized POLARIS dealer can perform any service that may be necessary for your vehicle.

POLARIS also recommends POLARIS parts, however equivalent parts may be used for such service. It is a potential violation of the Clean Air Act if a part supplied by an aftermarket parts manufacturer reduces the effectiveness of the vehicle's emission controls. Tampering with emission controls is prohibited by federal law.

CALIFORNIA RESIDENTS

Certain POLARIS Off-Road Vehicles are available in 49-state and 50-state versions. Only the 50-state models are certified for sale in California. The 50-state models available for sale in California are identified by the letter "B" in the ninth position of the model number (e.g., R16RTE87B). The POLARIS 50-state models are designed and built with features such as a reduced cargo box capacity. Any modifications to these features may be a violation of the applicable California regulations and may void this limited emissions warranty offered by the manufacturer.

POLARIS Inc. warrants that at the time it is first purchased, this vehicle is:

1. Designed, built, and equipped so as to conform, at the time of sale, with all applicable California evaporative emissions regulations.
2. Free from defects in materials and workmanship that may cause the failure of a warranted part as defined in California evaporative emissions regulations. All replacement parts must be identical in all material respects to that part as described in the OHRV manufacturer's Executive Order of Certification application.

The California evaporative emissions control system limited warranty statement below applies to your Off Highway Recreational Vehicle in California if the vehicle is equipped with an evaporative emission control system and is labeled with a Vehicle Evaporative Emissions Control Information label indicating that the vehicle conforms to California evaporative emissions regulations applicable to new off-road sport vehicles, all-terrain vehicles, or off-road utility vehicles. These vehicles are referred to as "OHRV-EVAP" below.

CALIFORNIA EMISSION CONTROL WARRANTY STATEMENT YOUR WARRANTY RIGHTS AND OBLIGATIONS

The California Air Resources Board and POLARIS Industries Inc. is pleased to explain the emission control system warranty on your model year 2018 and newer Off Highway Recreational Vehicle. In California, new off-highway recreational vehicles must be designed, built and equipped to meet the State's stringent anti-smog standards. POLARIS must warrant the emission control system on your OHRV-EVAP for the periods of time listed below provided there has been no abuse, neglect or improper maintenance of your OHRV-EVAP.

Your emission control system may include parts such as the carburetor or fuel injection system, fuel tank, fuel hoses, carbon canister, engine computer and Evaporative Emissions Control System parts listed in the U.S.A. EPA Emissions Limited Warranty. Also included may be hoses, belts, connectors and other emission-related assemblies. Where a warrantable condition exists, POLARIS will repair your OHRV-EVAP at no cost to you including diagnosis, parts and labor.

MANUFACTURER'S WARRANTY COVERAGE

For model year 2018 and newer OHRV-EVAP models.

For 30 months, or 2500 miles, or 250 hours, whichever comes first, except for evaporative components over the OHRV high-priced warranty value, which is covered for 60 months, or 5000 miles, or 500 hours, whichever comes first. If any emission-related part on your OHRV-EVAP is defective, the part will be repaired or replaced by POLARIS.

OWNER'S WARRANTY RESPONSIBILITIES

As the OHRV-EVAP owner, you are responsible for the performance of the required maintenance listed in your owner's manual. POLARIS recommends that you retain all receipts covering maintenance on your OHRV-EVAP, but POLARIS cannot deny warranty solely for the lack of receipts or for your failure to ensure the performance of a scheduled maintenance.

As an owner you are responsible for presenting your OHRV-EVAP to an authorized POLARIS dealer as soon as a problem exists. The warranty repairs should be completed in a reasonable amount of time, not to exceed 30 days.

As an OHRV-EVAP owner, you should also be aware that POLARIS may deny you warranty coverage if your OHRV-EVAP or a part has failed due to abuse, neglect, improper maintenance or unapproved modifications.

ORV / OHRV

WARRANTY

- POLARIS must honor the CARB-approved California emission warranty included in the Owner's Manual.
- POLARIS is liable for damages to other vehicle components proximately caused by a failure under warranty of any California emissions-warranted part.
- Any add-on or modified part exempted by the California Air Resources Board from the prohibitions of California Vehicle Code section 27156 may be used on a vehicle, engine, or trailer. Such use, in and of itself, shall not be grounds for disallowing a warranty claim made in accordance with California emission warranty requirements. POLARIS shall not be liable under CARB emissions warranty requirements to warranty failures of warranted parts caused by the use of an add-on modified part.

These requirements are based on the following provisions of the California Code of Regulations, which apply as written.

- 13 CCR §2419.1(d) Subject to the conditions and exclusions of subdivision (i), the warranty on emissions-related parts must function as follows.
 - (7) The OHRV manufacturer is liable for damages to other vehicle components proximately caused by a failure, under warranty, of any warranted part.
 - (10) Any add-on or modified part exempted by the Air Resources Board from the prohibitions of section 27156 of the California Vehicle Code may be used on an OHRV. Such use, in and of itself, will not be grounds for disallowing a warranty claim made under the provisions of this Article. The OHRV manufacturer is not liable under the provisions of this Article to warranty failures of warranted parts caused by the use of an add-on or modified part(s) unless such part(s) are also warranted.

ADD-ON OR MODIFIED PARTS

An add-on or modified part must be compliant with applicable CARB emission control standards. A violation of this requirement is punishable by civil and/or criminal punishment.

If you have any questions regarding your warranty rights and responsibilities, you should contact POLARIS Owner Connections at 1-800-POLARIS (1-800-765-2747) or the California Air Resources Board at 9528 Telstar Avenue, El Monte, CA 91731.

United States & Canada: 1-800-POLARIS (1-800-765-2747)

HOW THE CALIFORNIA EMISSIONS WARRANTY ON EVAPORATIVE EMISSIONS PARTS MUST FUNCTION AS PRESCRIBED IN 13 CCR §2419.1

- (1) Any warranted part which is not scheduled for replacement as part of maintenance in the Owner's Manual must be warranted for the warranty period. If any such part fails during the warranty period, it must be repaired or replaced by POLARIS according to subdivision (4) below. Any such part repaired or replaced under warranty must be fully warranted.
- (2) Any warranted part which is scheduled only for regular inspection in the Owner's Manual must be warranted for the warranty period. A statement in such written instructions to the effect of "repair or replace as necessary" must not reduce the period of warranty coverage. Any such part repaired or replaced under warranty must be warranted for the remaining warranty period.
- (3) Any warranted part which is scheduled for replacement as part of maintenance in the Owner's Manual must be warranted for the period of time prior to the first scheduled replacement point for that part. If the part fails before the first scheduled replacement point, the part must be repaired or replaced by POLARIS according to subdivision (4). Any such part repaired or replaced under warranty must be warranted for the remainder of the period prior to the first scheduled replacement point for the part.
- (4) Repair or replacement of any warranted part under the warranty provisions of this Article must be performed at no charge to the OHRV owner, at a warranty station, except in the case of a temporary repair when a warranted part or a warranty station is not reasonably available to the OHRV owner. In the event a temporary repair is permitted according to subdivision (8) below, repairs may be performed at any available service establishment, or by the owner, using any replacement part. POLARIS must reimburse the owner for his or her expenses including diagnostic charges for such temporary repair or replacement, not to exceed POLARIS' suggested retail price for all warranted parts replaced and labor charges based on the POLARIS recommended time allowance for the warranty repair and the geographically appropriate hourly labor rate.
- (5) Notwithstanding the provisions of subdivision (4) above, warranty services or repairs must be provided at all POLARIS dealerships that are owned by POLARIS or franchised to service the subject OHRVs.
- (6) The OHRV owner must not be charged for diagnostic labor which leads to the determination that a warranted part is, in fact, defective, provided that such diagnostic work is performed at a warranty station.
- (7) POLARIS is liable for damages to other vehicle components proximately caused by a failure, under warranty, of any warranted part.

WARRANTY

(8) Throughout the OHRV's evaporative emissions warranty period, POLARIS must maintain a supply of warranted parts sufficient to meet the expected demand for such parts. The lack of availability of such parts or the incompleteness of repairs within a reasonable time period, not to exceed 30 days from the time the OHRV is initially presented to the warranty station for repair, will qualify the need for a temporary repair for purposes of subdivision (4).

(9) Any replacement part designated by POLARIS may be used in warranty repairs provided without charge to the OHRV owner. Such use will not reduce the warranty obligations of POLARIS, except that POLARIS will not be liable under the provisions of this Article for repair or replacement of any replacement part which is not a warranted part (except as provided under subdivision (d)(7)).

(10) Any add-on or modified part exempted by the Air Resources Board from the prohibitions of section 27156 of the California Vehicle Code may be used on an OHRV. Such use, in and of itself, will not be grounds for disallowing a warranty claim made under the provisions of this Article. POLARIS is not liable under the provisions of this Article to warrant failures of warranted parts caused by the use of an add-on or modified part(s) unless such part(s) are also warranted.

(11) Upon a request of the Executive Officer, POLARIS must provide any documents that describe the manufacturer's warranty procedures or policies.

(12) Any replacement part must not reduce the effectiveness of the OHRV emission control system. POLARIS must demonstrate that the applicable emission standards are being met when the replacement part(s) are installed on the OHRV. The demonstration of equivalence to applicable emission standards can be achieved through replacing the part(s) with the evaporative emissions control components the OHRV evaporative family was certified with; or, if unavailable, alternative parts may be installed if POLARIS can provide test data to verify the evaporative control system meets, at least, the OHRV EFEL.

EXCLUSION

Notwithstanding the provisions of subdivisions (1) - (12) above, the repair or replacement of any warranted part otherwise eligible for the California Warranty on Evaporative Emission Parts, is excluded from such warranty coverage if POLARIS can provide evidence to the California Air Resources Board Executive Officer, to the Executive Officer's satisfaction, that the OHRV has been abused, neglected, improperly maintained, or had unapproved modifications and that such abuse, neglect, improper maintenance, or unapproved modification, was the direct cause of the need for the repair or replacement of the part.

MAINTENANCE LOG

MAINTENANCE LOG

Use the following chart to record periodic maintenance.

DATE	MILES (KM) OR HOURS	TECHNICIAN	SERVICE PERFORMED/ COMMENTS

A	D
Age Restrictions	Demand Drive.....
Air Filter / Air Box.....	Descending Hills Improperly
Air Filter Installation	Diagnostic Display Code
All Wheel Drive System.....	Definitions
EVAP Models	Drive Belt
2x4 Mode.....	Installation
AWD Mode.....	Removal.....
Automatic Transmission Gear	Drive Belt Wear/Burn.....
Selector	Drive Mode Switch.....
Auxiliary Foot Brake	Driveline Switch
	Driving Downhill
	Driving in Reverse
	Driving on a Sidehill (Sidehilling) ...
	Driving on Slippery Surfaces
	Driving Over Obstacles
	Driving Through Water.....
	Driving Uphill
B	E
Battery	Electromagnetic Interference
Identification	Electronic Power Steering (EPS) (if
Battery Charging	equipped)
Battery Installation	Tri-Mode Settings
Battery Maintenance	Engine and Drivetrain Break-In
Battery Removal.....	Engine Backfires
Battery Storage	Engine Doesn't Turn Over
Belt Life	Engine Oil.....
Bluetooth® Pairing.....	Engine Pings or Knocks
Boots	Engine Runs Irregularly, Stalls
Brake Fluid Level.....	or Misfires
Brake Lever.....	Engine Stop Switch.....
Brake System	Engine Stops or Loses Power ...
Break-In	Engine Turns Over, Fails to
Brakes	Start.....
	Exhaust Emission Control
	System
	Exported Products
	Exposure to Exhaust
	Eye Protection
C	
California Residents	
Camber and Caster.....	
Cargo Warning.....	
Clean the Exterior.....	
Cleaning and Storage	
Clothing.....	
Cold Weather Operation.....	
Cooling System.....	
Crankcase Emission Control	
System	
Crossing Hillside.....	
Crossover Ring Adjustment	

F

Failure to Inspect Before Operating	14
Fluid Levels	141
Fluid Part Numbers	147
Fog the Engine	141
Front Compartment	39
Front Gearcase Fluid Change	99
Fluid Check	99
Fuel Cap	37
Fuel Recommendation	71
Fuel Stabilizer	141
Fuse Replacement	110

G

Gloves	12
--------------	----

H

Hand Brake	104
Handlebars	137
Handling Gasoline	14
Hauling Cargo Guidelines	74
Headlamp Replacement	114
Headlight Beam Adjustment	114
Headlight Switch	30
Helmet	12
High Beam Adjustment	113
High/Low Speed Compression Adjustment	136
Hot Exhaust Systems	23

I

Ignition Switch/Light Switch	29
Improper Cargo Loading	22
Improper Hill Climbing	17
Improper Tire Maintenance	20
Inspect and Lubricate	141
Instrument Cluster	42
Back Light Color	52
Back Light Level	53
Bluetooth® (if equipped)	55

Clock	51
Diagnostic Code	48
Display Area 1	45
Display Area 2	46
Indicator Lamps	44
Options Menu	47
Service Hours	54
Unit Selection Distance	49
Unit Selection Temperature	50

J

Jumps and Stunts	17
------------------------	----

K

Key Replacement	8
Know Your Riding Area	58

L

Lead Acid Conventional Batteries	131
Lead Acid Low Maintenance Battery	133
Lubricants / Service Products	147
Lubrication Guide	93

M

Maintenance Periodic	89
Maintenance Interval Chart	90
Maintenance Log	171
Master Cylinder / Brake Fluid	35
Mode/Reverse Override Switch	30
Modifications to Vehicle	24

N

New Operator Driving Procedures	62
--	----

Noise Emission Control System 87

O

Oil and Filter 141
Oil and Oil Filter Change 96
Oil Level Check 95
Oil Recommendations 94
Operating a Damaged Vehicle 21
Operating at Excessive Speeds 16
Operating Improperly in Reverse... 20
Operating in Unfamiliar Terrain 19
Operating on Frozen Bodies of
Water 22
Operating on Pavement 15
Operating on Public Roads 15
Operating on Slippery Terrain 19
Operating on Steep Hills 19
Operating Over Obstacles 20
Operating Through Water 21
Operation on Public Lands in
the U.S.A..... 87

P

Parking Brake 34
Parking on an Incline 72
Parking the Vehicle 72
Part Numbers 147
Periodic Maintenance Chart 89
Physical Control of the Vehicle 16
Physical Skills 22
POLARIS Products 147
Polishing the Vehicle 140
Poor Visibility 22
Power Steering Unit (Cleaning)... 103
Pre-Ride Checklist 61
Protective Apparel 15
PVT Break-in (Clutches/Belt) 60
PVT System 120

R

Radiator Coolant 104
Radio Compliance Statements 8

Rear Gearcase Oil 101
Rebound Damping Adjustment ... 137
Recovery Bottle Coolant 103
Reporting Safety Defects
(Canada).....9

S

Safe Operation Practices 57
Safe Riding Gear 11
Safety Labels and Locations 25
4x4 (AWD) Caution 27
Age 16 Warning 26
Clutch Cover Warning..... 27
Discretionary Warning 28
General Warning 26
No Passenger Warning..... 27
Rack Warning 28
Reverse Override Warning 26
Tire Pressure / Load Warning 27
Safety Symbols 4
Safety Training..... 11
Safety Warnings 13
Safety, Winch Maintenance..... 86
Seat Removal 105
Shock Loading the Winch 85
Side Panel/Footwell Removal..... 105
Signal Words 4
Skidding or Sliding 21
Spark Arrester 117
Spark Plug Inspection..... 114
Spark Plug Recommendations 114
Spark Plugs..... 114
Specifications
Scrambler XP 1000 S 143
Spring Preload Adjustment 135
Stabilize the Fuel..... 141
Stalling While Climbing a Hill..... 18
Starting the Engine 70
Steering Assembly..... 103
Stopping the Engine..... 70
Storage 140
Storage Area 142
Switches
Overview 29

T

Taillight/Brake Light Lamp Replacement	114
Throttle Body/Idle RPM	137
Throttle Lever	31
Tire Tread Depth	106
Tires	106
Toe Alignment	108
Towing Loads	75
Trademarks	2
Trail Etiquette	58
Trailer Hitch Warning	23
Transmission Oil	97
Transporting the ATV	142
Tread Lightly SM	58
Turning Around on a Hill (K-Turn)	66
Turning Improperly	16

Wet Fouled Plug	115
Wheel Installation	107
Wheel Nut Torque Specifications	107
Wheel Removal	106
Winch	
Winch Operation	79
Winch Safety Precautions	77
Winch Cable Care	84
Winch Maintenance and Service Safety	86
Winch Shock Loading	85

U

Unauthorized Use of the Vehicle ...	23
-------------------------------------	----

V

Vehicle Break-in Period	59
Vehicle Identification Numbers	7
Vehicle Immersion	116

W

Warning Symbols	4
Warranty	
How to Obtain Warranty	
Service	162
Limitations	160
Limited Warranty	159
Lubricants and Fluids	161
Notice	163
Registration	159
U.S.A. EPA Emissions Limited Warranty	164
Washing the Vehicle	139
Washing Tips	139
Welcome Page	3

WARNING

Improper ATV use can result in SEVERE INJURY or DEATH.



**ALWAYS USE AN
APPROVED
HELMET AND
PROTECTIVE GEAR**



**NEVER USE ON
PUBLIC ROADS**



**NEVER CARRY
PASSENGERS**



**NEVER USE WITH
DRUGS OR
ALCOHOL**

Never operate:

- without proper training or instruction
- at speeds too fast for your skills or the conditions
- on public roads - a collision can occur with another vehicle
- with a passenger - passengers affect balance and steering and can increase risk of losing control

Always:

- use proper riding techniques to avoid vehicle overturns on hills and rough terrain and in turns
- avoid paved surfaces - pavement may seriously affect handling and control



SCAN CODE FOR PRODUCT AND SAFETY
INFORMATION. FOLLOW ALL INSTRUCTIONS
AND WARNINGS

For your nearest Polaris dealer,
call 1-800-POLARIS (765-2747)
or visit www.polaris.com



Polaris Inc.
2100 Highway 55
Medina, MN 55340

Part No. 9941614 Rev 02
Printed in USA