

2024



For Maintenance and Safety

OWNER'S MANUAL

General XP 1000

POLARIS
Think Outside



WARNING

Read, understand, and follow all of the instructions and safety precautions in this manual and on all product labels.

Failure to follow the safety precautions could result in serious injury or death.



WARNING

Operating, servicing, and maintaining a passenger vehicle or off-road vehicle can expose you to chemicals including engine exhaust, carbon monoxide, phthalates, and lead, which are known to the State of California to cause cancer and birth defects or other reproductive harm. To minimize exposure, avoid breathing exhaust, do not idle the engine except as necessary, service your vehicle in a well-ventilated area and wear gloves or wash your hands frequently when servicing your vehicle.

For more information go to www.P65Warnings.ca.gov/passenger-vehicle.



*For videos and more information
about a safe riding experience with
your Polaris vehicle, scan this QR
Code® with your smartphone
or visit: www.polaris.com/en-us/safety*

POLARIS
GENERAL

2024 Owner's Manual

General XP 1000 Sport
General XP 1000 Premium
General XP 1000 Ultimate

Unless noted, trademarks are the property of Polaris Industries Inc.

Recreational Off-Highway Vehicle Association® and ROHVA® are registered trademarks of Recreational Off-Highway Vehicle Association. BatteryMINDer® is a registered trademark of VDC Electronics Inc. Loctite® is a registered trademark of Henkel Corporation. NYOGEL® is a registered trademark of Nye Lubricants, Inc. WD-40® is registered to WD-40 Manufacturing Company. QR Code® is a registered trademark of DENSO WAVE INCORPORATED. Apple® and APP STORE® are registered trademarks of Apple Inc. Google Play® is a registered trademark of Google, LLC. OSHA® is a registered trademark of the Occupational Safety and Health Administration, U.S. Dept. of Labor. MACPHERSON RIDE® is a registered trademark of Aftermarket Auto Parts Alliance, Inc. Tread Lightly® is a registered trademark of the United States Department of Agriculture. Carlisle® is a registered trademark of CARLISLE INTANGIBLE, LLC. High Lifter® is a registered trademark of NIVEL PARTS & MANUFACTURING CO.

Copyright 2024 Polaris Industries Inc. All information contained within this publication is based on the latest product information at the time of publication. Due to constant improvements in the design and quality of production components, some minor discrepancies may result between the actual vehicle and the information presented in this publication. Depictions and/or procedures in this publication are intended for reference use only. No liability can be accepted for omissions or inaccuracies. Any reprinting or reuse of the depictions and/or procedures contained within, whether whole or in part, is expressly prohibited.

The original instructions for this vehicle are in English. Other languages are provided as translations of the original instructions.

Printed in U.S.A.

9941301 R01



Thank you for purchasing a POLARIS vehicle, and welcome to our world-wide family of POLARIS enthusiasts. Be sure to visit us online at www.polaris.com for the latest news, new product introductions, upcoming events, career opportunities and more.

Here at POLARIS we proudly produce an exciting line of utility and recreational products. We believe POLARIS sets a standard of excellence for all utility and recreational vehicles manufactured in the world today. Many years of experience have gone into the engineering, design, and development of your POLARIS vehicle, making it the finest machine we've ever produced.

For safe and enjoyable operation of your vehicle, be sure to follow the instructions and recommendations in this owner's manual. Your manual contains instructions for minor maintenance, but information about major repairs is outlined in the POLARIS Service Manual and can be performed by a factory certified Master Service Dealer (MSD) technician.

Your POLARIS dealer knows your vehicle best and is interested in your total satisfaction. Your POLARIS dealership can perform all of your service needs during and after the warranty period.

For the most up-to-date owner's manual visit <https://www.polaris.com/en-us/owners-manuals>.

WELCOME

Introduction	7
Safety	13
Features and Controls	33
Operation	53
Emission Control Systems	65
Maintenance	67
Specifications	107
POLARIS Products	109
Troubleshooting	111
Warranty	115
Maintenance Log	127

INTRODUCTION

BEFORE YOU RIDE

This POLARIS vehicle is an off-road vehicle. Familiarize yourself with all laws and regulations concerning the operation of this vehicle in your area.

WARNING

Failure to heed the warnings and safety precautions contained in this manual can result in severe injury or death. Your POLARIS vehicle is not a toy and can be hazardous to operate. This vehicle handles differently than cars, trucks or other off-road vehicles. A collision or rollover can occur quickly, even during routine maneuvers like turning, or driving on hills or over obstacles, if you fail to take proper precautions.

- Read this owner's manual and review the safety DVD that came with your vehicle. A free extra copy of the DVD can be obtained by contacting your local POLARIS dealer. Understand all safety warnings, precautions and operating procedures before operating the vehicle. Keep this manual with the vehicle.
- Never operate this vehicle without proper instruction. Take an authorized training course. See the Safety Training section for more information.
- This vehicle is an **ADULT VEHICLE ONLY**. You **MUST** be at least age 16 and have a valid driver's license to operate this vehicle.
- Always use the cab nets (or doors) while riding in this vehicle. Always keep hands, feet and all other body parts inside the vehicle at all times.
- Always wear a helmet, eye protection, gloves, long-sleeve shirt, long pants and over-the-ankle boots.
- Never operate this vehicle under the influence of drugs or alcohol, as these conditions impair judgement and reduce the operator's ability to react.
- Complete the New Operator Driving Procedures outlined in this manual. Never allow a guest to operate this vehicle until the guest has completed the New Operator Driving Procedures.
- Never permit a guest to operate this vehicle unless the guest has reviewed the owner's manual and all safety labels and has completed a safety training

INTRODUCTION

SAFETY SYMBOLS AND SIGNAL WORDS

The following signal words and symbols appear throughout this manual and on your vehicle. Your safety is involved when these words and symbols are used. Become familiar with their meanings before reading the manual.

DANGER

DANGER indicates a hazardous situation which, if not avoided, WILL result in death or serious injury.

WARNING

WARNING indicates a hazardous situation which, if not avoided, COULD result in death or serious injury.

CAUTION

CAUTION indicates a hazardous situation which, if not avoided, COULD result in minor to moderate injury.

NOTICE

NOTICE provides key information by clarifying instructions.

IMPORTANT

IMPORTANT provides key reminders during disassembly, assembly, and inspection of components.

The Prohibition Safety Sign indicates an action NOT to take in order to avoid a hazard.



The Mandatory Action Sign indicates an action that NEEDS to be taken to avoid a hazard.



NEAR-FIELD COMMUNICATION (NFC) (IF EQUIPPED)

Some Polaris vehicles come equipped with a near-field communication (NFC) chip. The NFC chip is embedded in the Polaris emblem located at the front of the vehicle and seamlessly connects you to a digital platform of vehicle information and tools. See your dealer for more information.

IMPORTANT

Not all devices are equipped with an NFC reader. Additionally, some devices require third party applications to access NFC content. For questions regarding the NFC reader on your device, refer to the device's user manual.

On models equipped with NFC, place your smartphone directly over the Polaris emblem to do the following:

- View vehicle-specific information
- Access your Polaris Garage
- Download and view the owner's manual
- View accessory instructions
- Watch how-to videos
- Access warranty information
- Check for service notifications



RIDE COMMAND WITH NFC

Additional NFC features are available when using the Ride Command mobile app. To access these features, do the following:

1. Download the Ride Command mobile app from the Apple App Store® or Google Play® store.
2. Create or log in to an existing account.
3. From the Ride Command mobile app home screen, select **Add Vehicle**.
4. On the vehicle, tap the NFC-enabled badge with the phone to scan the vehicle.
5. Confirm information, name your vehicle, and tap add to garage.

SYSTEM REQUIREMENTS

Refer to device manufacturer's instructions to verify NFC read capability, and/or NFC-capable add-ons.

INTRODUCTION

RADIO COMPLIANCE STATEMENTS

NOTE

Some vehicle models contain radio equipment as detailed in this section.

USA RADIO COMPLIANCE

Some models within this vehicle configuration contain the following radio equipment:

COMPONENT	COMPONENT ID	MANUFACTURER
Digital Media Receiver	PMX-P2	Rockford Corporation
9200 Series Display	RC-7	Polaris Industries Inc.
V2V Antenna	4017534	Laird

This device complies with part 15 of the FCC Rules. Operation is subject to the following two conditions: (1) This device may not cause harmful interference, and (2) this device must accept any interference received, including interference that may cause undesired operation.

CAUTION

Changes or modifications not expressly approved by the party responsible for compliance could void the user's authority to operate the equipment.

CANADA RADIO COMPLIANCE

Some models within this vehicle configuration contain the following radio equipment:

COMPONENT	COMPONENT ID	MANUFACTURER
Digital Media Receiver	PMX-P2	Rockford Corporation
9200 Series Display	RC-7	Polaris Industries Inc.
V2V Antenna	4017534	Laird

This device contains license-exempt transmitter(s)/receiver(s) that comply with Innovation, Science and Economic Development Canada's license-exempt RSS (s). Operation is subject to the following two conditions:

1. This device may not cause interference.
2. This device must accept any interference, including interference that may cause undesired operation of the device.

IMPORTANT

For applications that use vehicle-to-vehicle (V2V) communication, radio transmitter IC 5966A-P001 has been approved by Innovation, Science and Economic Development Canada (ISED) to operate with Polaris antenna (part number 4017534) with gain of 2.5dBi. Any antenna that has a gain greater than 3 dBi is prohibited for use with this device.

EUROPEAN UNION (EU) RADIO COMPLIANCE

Some models within this vehicle configuration contain the following radio equipment:

Component	Digital Media Receiver	9200 Series Display
Component ID	PMX-P2	RC-7
Manufacturer	Rockford Corporation	Polaris Industries Inc.
*Transmitting Frequency	2402 - 2480 MHz	2.4 MHz
Max RF Transmitting PWR	-0.51 dBm EIRP	100 mW
*Other transmitting radio frequencies may exist outside of EU markets.		

Hereby, Polaris Industries Inc. declares that the above radio equipment is in compliance with Directive 2014/53/EU.

The full text of the EU declaration of conformity is available at the following internet address:

<https://www.polaris.com/en-us/radio-conformity/>

INTRODUCTION

VEHICLE IDENTIFICATION NUMBERS

Record your vehicle's identification numbers and key number in the spaces provided. Remove the spare key and store it in a safe place. An ignition key can be duplicated only by ordering a POLARIS key blank (using your key number) and mating it with one of your existing keys. The ignition switch must be replaced if all keys are lost.

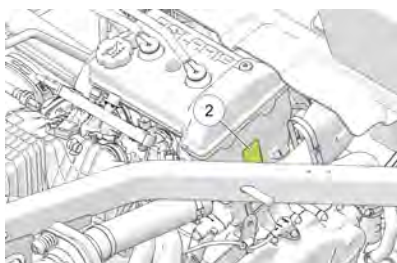
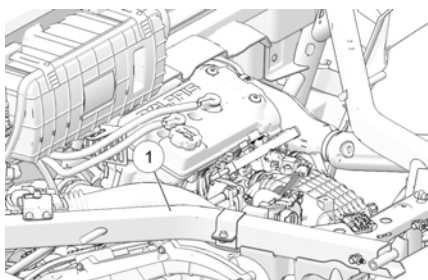

Vehicle Model Number:	
Frame VIN ①:	
Engine Serial Number ②:	
Key Number	

SAFETY

OWNER REQUIREMENTS

Improper use, maintenance, or modification of this vehicle can lead to serious injury or death.

Require proper use of your vehicle. Do not allow anyone to operate your vehicle or ride as a passenger unless they are properly instructed and you are sure they are willing to ride responsibly. To prevent unauthorized use, always remove the ignition key when the vehicle is not in use.



Any modifications or installation of non-POLARIS-approved accessories could increase the risk of injury. While you may find aftermarket products similar in design and quality to POLARIS accessories, recognize that some aftermarket accessories or modifications are not suitable because of potential safety hazards to you or others. It is never appropriate to install any additional seating.

Check with the manufacturer to determine any potential effect of a modification or accessory on the safe use of your vehicle. You are responsible for injuries related to modifications to the vehicle. Modifications or accessories may:

- Damage machine components - especially modifications that increase speed or power.
- Make the vehicle less stable at higher speeds.
- Add weight, reducing the amount of cargo and total weight you can carry, and raise the vehicle's center of gravity.
- Overload the vehicle's electrical system capacity. Blowing a fuse may cause a loss of lights or engine power.
- Reduce the effectiveness of occupant protection systems, including the seatbelts and the Rollover Protective Structure (ROPS).
- Make it illegal to own or operate your vehicle. POLARIS-authorized spark arresters, mufflers, and emissions control components are mandatory for ownership or operation in many areas.
- Void your warranty.

The vehicle ROPS, when used with the seat belts and doors, provides a structure to help protect occupants. The structure will not protect occupants in all rollovers or accidents.

For more information about safety, contact an authorized dealer or visit the Polaris website at www.polaris.com.

DRIVER AND PASSENGER QUALIFICATIONS

Make sure operators are 16 or older with a valid driver's license. Just because a teenager has a license does not mean that they will make good judgments about driving and avoid risk taking.

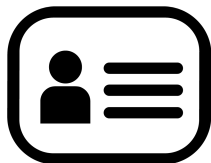

POLARIS recommends that you supervise younger drivers. Set rules and put limits on how, when, and where they are allowed to use this vehicle. For example, young drivers may need to have an adult in the vehicle with them and not be allowed to drive with their friends in the vehicle.

Make sure all riders fit the vehicle. Be sure that the driver and all passengers are able to:

- sit with their backs against their seat,
- adjust the seat belt to fit properly,
- have both feet flat on the floor, and
- have both hands on the steering wheel or on a passenger hand hold.

Do not allow children who need child safety seats or booster seats to ride in the vehicle. The vehicle is not designed to restrain automotive child safety seats.

You are responsible for your passengers. Be sure passengers are seated properly, belted, holding the passenger hand hold, and ready to brace. Unrestrained riders can fall out or be thrown around and from a moving vehicle.

Every person must be properly seated and belted in their own seat. Two people should never be belted into a single seat belt. People belted together can crash into one another in a collision and be seriously injured. Never carry passengers in the cargo bed as they could be thrown against or out of the vehicle or come into contact with moving parts.

Do not let people drive or ride after using alcohol or drugs.

PREPARE VEHICLE FOR THE RIDE

Before starting off, always perform the Pre-Ride Inspection. Failure to inspect and verify that the vehicle is in safe operating condition increases the risk of an accident, which can lead to serious injury or death.



ITEM	REMARK	REFERENCE
Brake Fluid	Ensure proper level and condition	page 89
Front and rear suspension	Inspect	—
Steering	Ensure free operation	page 85
Tires	Inspect condition and pressure	page 30 page 93
Wheels/Lug Nuts	Inspect, ensure fastener tightness	page 93
Fuel and oil	Ensure proper levels and condition	page 73
Coolant	Ensure proper level and condition	page 81
Indicator lights/switches	Ensure proper operation	page 35 page 45
Air Filter	Inspect, replace as needed	page 86
Engine intake pre-filter	Inspect, clean	—
PVT intake pre-filter	Inspect, clean	—
Headlights	Check operation	—
Brake lights/taillights	Check operation	—
Seat Belts	Check length of belt for damage, check latches for proper operation.	page 39

SAFETY

ITEM	REMARK	REFERENCE
Exhaust	Inspect spark arrester and clean if needed.	page 86
Vehicle Debris	Remove grass, leaves, and other flammable material or debris, especially near the exhaust system.	-
Lock adjustable steering wheel	Do not adjust the steering wheel while the vehicle is moving.	-

Improper tire maintenance can lead to loss of control and an accident, which could result in serious injury or death. To reduce your risk of injury:

- Maintain POLARIS recommended tire pressure. Check pressure before operating. Even if your vehicle has only been driven a short distance, the tire pressure readings can become higher.
- Make sure tire pressures match the specifications listed in the table below.
- Only use the size and type of tires specified for this vehicle.
- Do not operate your vehicle with worn or damaged tires.
- Always follow your tire manufacturer's instructions for maintenance.

PREPARE YOURSELF, PASSENGERS, AND CARGO FOR THE RIDE

Wear an approved helmet. Riding in this vehicle without wearing an approved helmet increases the risk of serious injury. For example, a helmet reduces your risk of injury from head strikes with the vehicle or other objects even if there is no crash.

Approved helmets in the USA and Canada bear a U.S. Department of Transportation (DOT) label. Approved helmets in Europe, Asia, and Oceania bear the ECE 22.05 label. The ECE mark consists of a circle surrounding the letter E, followed by the distinguishing number of the country which has granted approval. The approval number and serial number will also be displayed on the label.



Use shatterproof goggles or a shatterproof helmet face shield. Such protective eyewear may reduce the risk of foreign material getting in your eyes and help prevent loss of vision.

POLARIS recommends wearing approved Personal Protective Equipment (PPE) that have markings indicating they are designed to standards such as:

- VESC 8
- V-8
- Z87.1
- CE



Additional protective clothing and gear that may be appropriate for your riding conditions includes:

- Always wear shoes when operating. Consider wearing sturdy over-the-ankle boots suitable for the terrain you will be riding in.
- Full-finger gloves can protect against wind, sun, cold, and objects. Choose gloves that fit snugly and allow fingers to move freely and grip on the steering wheel or hand holds.
- Consider long sleeves and long pants to help protect arms and legs.
- Long-term exposure to wind and engine noise can cause permanent hearing loss. Properly worn hearing protective devices such as earplugs can help prevent hearing loss. Check local laws or the rules of the riding area you are in before wearing hearing protection to make sure its use is permitted.

Always stay completely inside the vehicle and hold the steering wheel or hand holds. Body parts outside of the vehicle can be struck by passing objects or crushed during a rollover. Do not put any part of your body outside of the vehicle for any reason. Do not hold onto the ROPS frame or put any part of your body on the door.

Riding in this vehicle without closed and latched cab doors increases the risk of serious injury or death in the event of an accident or rollover. Always make sure all cab doors are closed and latched while riding in this vehicle.

Be sure riders pay attention and plan ahead. If you think or feel the vehicle may tip or roll, reduce your risk of injury:

- Keep a firm grip on the steering wheel or hand holds and brace yourself.
- Do not put any part of your body outside of the vehicle for any reason.

This vehicle is not designed to carry unrestrained pets. An unrestrained pet can be thrown about and injure riders, even during normal operation. When transporting pets, use a pet crate suitable for off-road use that is secured to the vehicle.

Fuels such as gasoline can be extremely flammable. To reduce the risk of serious injury or death, never carry fuel or other flammable liquids on this vehicle. Rollovers, crashes, rough riding, or changes in elevation or temperature may lead to fuel spilling or vapor release from portable containers. Hot vehicle parts can cause fires, even after the engine has been turned off.

Never exceed vehicle weight capacities. The vehicle's maximum weight capacity varies depending on model. The cargo box can support up to 600 lbs. (272 kg) of that total. When more rider weight is added, cargo weight may need to be eliminated to stay under the limit. Overloading the vehicle or carrying cargo improperly will cause changes in stability and handling, which could cause loss of control or an accident.

Secure cargo in the cargo box as far forward, centered and as low as possible. When cargo cannot be positioned and secured in this way, operate with extra caution. Unsecured cargo can strike and injure riders, affect vehicle handling, and result in loss of control.

The weight of riders and cargo changes vehicle braking, handling, and stability. To avoid loss of control, turn gradually, operate at slower speeds, and avoid rougher or steeper terrain.

DRIVING GUIDELINES

Drive Responsibly. This vehicle has higher ground clearance and other features to handle rugged terrain. It can be overturned in situations where some other vehicles may not. Abrupt maneuvers or aggressive driving, even on flat, open areas, can cause loss of control, rollovers, severe injury or death. To avoid loss of control and rollovers:



- Avoid abrupt maneuvers, sideways sliding, skidding, or fishtailing, and never do donuts.
- Slow down before entering turn.
- Avoid hard acceleration when turning, even from a stop.

High speed off-road operation

Driving off-road vehicles to test the limits of your skills or abilities can be very dangerous to you, passengers, and bystanders. Basic skills for driving a car, ATV, or other off-road vehicles do not equip drivers to safely attempt high speed off-road operation. Develop your skill gradually through training, practice, and experience with the various driving modes of this vehicle and the terrain in which you are operating. Always do a low speed reconnaissance run (prerun) to become aware of anything you may encounter.

High speed off-road operation can lead to loss of control, crashes, or hard landings that can seriously injure occupants (even without rolling the vehicle or damaging it).

If you plan on using the vehicle for high speed, off-road competition, additional safety equipment may be necessary. Check the rules that apply to your competition.

Do not go over jumps — going airborne can lead to serious injury or death.

Going airborne can cause loss of control, rollovers, or crashing into the ground and may damage the vehicle. Even without crashing, landings can be hard enough to cause any vehicle suspension to fully compress (e.g., bottom out). Serious injuries, including spinal injuries, can occur even if riders are properly harnessed, wearing helmets and the vehicle is not damaged and remains upright.

You may encounter slopes, "jumps", or other terrain features that could send the vehicle airborne, depending on your speed. These may be defectively designed, poorly maintained, or not suitable for this vehicle. Slow down, use extra care, and avoid going airborne. Never take this vehicle over jumps.

Watching someone else go over a jump or go airborne does not mean you can safely do so. Polaris cannot determine whether any jump you may encounter is appropriate for this vehicle. Any jump, even a small one, could be poorly maintained, designed, or not suitable for this vehicle and may cause serious injury or death.



Plan for hills, rough terrain, ruts, and other changes in traction and terrain.

Proceed slowly and with extra care on unfamiliar terrain. Avoid paved surfaces. Sudden changes in terrain such as holes, depressions, banks, softer or harder ground, or other irregularities may cause loss of control or rollover. Give yourself time to react to rocks, bumps, or holes that may be hard to see. Operating in deep snow or tall grass may make it harder to see obstacles.

If you cannot go around an obstacle, such as a fallen tree or a ditch, stop the vehicle in a safe place. Get out to inspect the area thoroughly. Look from both your approach side and exit side. If you are reasonably confident you can continue safely, choose the path that will allow you to go straight over the obstacle to minimize the vehicle tipping sideways. Go only fast enough to maintain your momentum, but still give yourself plenty of time to react to changes in conditions. If there is any question about your ability to maneuver safely over the obstacle, you should turn around if the ground is flat and you have the room, or back up until you find a less difficult path.

Abrupt application of the accelerator pedal can cause the tires to lose traction, reducing control of the vehicle and increasing the possibility of an accident, especially while on sloped terrain or while crossing obstacles such as rocks or logs.

Avoid Operating on Public Roads (Paved or Otherwise). This vehicle does not have highway safety features that on-road vehicles may have (air bags, anti-lock brakes, stability control, etc.). If another vehicle collides with you, the likelihood of a serious injury or death may be greater. Also, you may not be able to avoid a crash or rollover if you make sudden or abrupt maneuvers such as swerving or emergency braking.

While it may be legal to drive on some public roads, it is recommended that you avoid on-road operation. If you must drive on-road, drive slowly and defensively. Use extra care. You may also need to make vehicle modifications to comply with state or local laws. In addition, refer to tire manufacturer's instructions or limitations for on-road operation, including speed limits and premature tire wear.

SAFETY

Improperly operating on hills can cause loss of control, rollover, or accident, which can lead to serious injury or death. Use extra care when operating on hills. Plan for rough terrain, ruts, and other changes in traction and terrain.

Driving up hills

Check the terrain before ascending a hill and make sure it is not too slippery or loose. Engage all-wheel drive for hills. Drive straight uphill, keeping speed and throttle steady. Avoid steep hills which can cause the vehicle to overturn.

Recovering from stalling on a hill

If the vehicle loses forward speed, apply the brakes gradually and stop. Do not attempt to turn the vehicle around. Instead, shift to reverse and allow the vehicle to slowly roll straight downhill. Apply light brake pressure to control speed.

Overtopping a hill

Slow down when you reach the crest of a hill. Never blindly go over the crest of a hill or a drop off at high speed. An obstacle, a sharp drop, or another vehicle or person could be on the other side of the hill.

Driving down hills

Check the terrain before descending a hill and make sure it is not too slippery or loose. Engage all-wheel drive and proceed slowly, applying the brakes lightly. Never descend a hill with the transmission in neutral or if the engine is turned off.

Avoid side hilling (riding across slopes)

If unavoidable, proceed slowly and with extra caution. Avoid obstacles and changes in terrain that could cause the vehicle to tip or slide. If it feels like the vehicle begins to tip or slide, immediately turn downhill.

Riding near wooded areas or brush

Use extra caution when operating near trees, particularly when operating on narrow trails. Tree branches or brush can be driven into the cab striking or stabbing occupants.



Riding in snow

Always keep the brake and accelerator pedals free of snow and ice. Apply the brakes frequently to prevent ice or snow accumulation on the brake pads which can reduce brake performance.

Riding on ice

Never operate the vehicle on a frozen body of water unless you have verified that the ice can support the weight of the vehicle. Severe injury or death can result if the vehicle falls through the ice.

Riding in water / Falling into water

Operating through deep or fast-flowing water can cause loss of traction, loss of control, overturning, or being swept away in water. You can be seriously injured or killed from entrapment and drowning. Never operate the vehicle in fast-flowing water or in water that exceeds the floor level of the vehicle. Avoid sharp drop-offs and large rocks. Choose a path that provides an entrance and exit point with gradual inclines. Wet brakes may have reduced stopping ability. After leaving water, test the brakes. Apply them lightly several times while driving slowly. The friction will help dry out the pads.

Riding on sand dunes

Use extra caution when operating on or near dunes. Be alert for changes in terrain. Never blindly go over the crest of a hill or a drop-off at high speed. An obstacle, a sharp drop, or another vehicle or a person could be on the other side of the hill.

Riding in low-visibility conditions

Use extra caution and drive slowly in conditions of reduced visibility such as fog, rain, and darkness.

Plan ahead to avoid the need for evasive maneuvers, such as swerving.

Hitting an obstacle — including wildlife — you are not ready for can be dangerous. Choosing to swerve instead can be even more dangerous because it can lead to loss of control, rollover, or collisions.

When operating in areas with possibility of wildlife appearing in your path, plan ahead to avoid swerving for animals if doing so could result in collisions or rollovers. Go slowly or avoid driving during seasons or times of day when animals such as deer are more likely to cross your path without warning.

Avoid Collisions With Other Vehicles

When following another vehicle or operating in the same area as others, keep a safe distance to avoid collisions. Allow extra space when sight distances are limited by dust, snow, curves, hills, or other conditions. Plan ahead to avoid having to swerve or leave the trail to avoid a collision.

On trails, be prepared to make space for other vehicles to pass. If you need to stop on a trail, move your vehicle to the edge of the path to allow others to pass safely.

Correct a skid by turning the steering wheel in the direction of the skid.

Never apply the brakes during a skid.

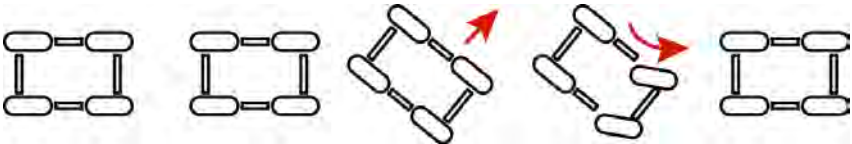

SAFETY

If the vehicle begins to slide downhill or you feel it may tip, turn downhill immediately and stop. Maneuver slowly and carefully until you can drive straight downhill.

Do not continue driving if your vehicle may be damaged or if you were in a crash or rollover.

Operating the vehicle while damaged or after a crash or rollover can cause loss of control, rollover, or accident, which can lead to serious injury or death. If you cannot safely transport the vehicle on your own, contact a recovery and towing service.

After any crash, rollover, or other accident, have a POLARIS dealer inspect the vehicle for possible damage, including seat belts, ROPS, brakes, suspension, and steering systems.

Be prepared in case your vehicle becomes damaged or disabled, especially in remote areas. Consider in advance how to get help and stay safe until it arrives whenever you ride.

There is a recovery tow loop at the front and back of the vehicle to attach a winch or strap.

Use these loops to recover this vehicle if it is stuck, to pull it onto a tow truck, trailer, or to use this vehicle to recover another vehicle. These loops are for emergency recovery only and are not for towing vehicles to another location.

Improper recovery may lead to loss of control or vehicle damage. Only attach straps to specified locations. Do not attach to any other point on the vehicle. Only recover a vehicle of equal or lesser size and weight. When recovering a disabled vehicle, place the disabled vehicle's transmission in neutral. Do not move a disabled POLARIS vehicle faster than 10 mph (16 km/h).

Operating, Idling, Or Parking Near Combustible Materials

Engine, exhaust, and other vehicle components can be very hot during and after use. Do not idle or park the vehicle over anything that could contact the exhaust system and catch on fire, such as tall grass, weeds, brush, leaves, debris, or other tall ground cover. Do not let mud, grass, or other debris accumulate on the engine or exhaust system. Inspect and remove as needed.

Vehicle rollaway can cause serious injury or death. This vehicle can roll whenever the gear selector is not in the PARK (P) position. Always shift to PARK (P) when stopping the engine or leaving the vehicle. When leaving the vehicle on an incline is unavoidable, use extra care. If leaving the vehicle unattended, block the rear wheels on the downhill side and keep children, pets, and others away from the gear selector.

Before shifting into reverse, use extra care to make sure the area is clear of people or obstacles. When it's safe to proceed, back slowly.

SAFETY

After operation, inspect the vehicle for damage and debris to make sure the vehicle can be safely stored and operated again. Some things to inspect include:

- Debris that could catch fire, such as mud/grass near the engine or exhaust system
- Damage to the suspension, steering, or any other part of the vehicle
- Tire condition, such as tread and sidewall damage
- Shock absorber assembly condition

Be sure to have any issues checked and problems fixed before operating again.

All engine exhaust contains carbon monoxide, a deadly gas. Breathing carbon monoxide can cause headaches, dizziness, drowsiness, nausea, confusion, and eventually death. Carbon monoxide is a colorless, odorless, tasteless gas which may be present even if you do not see or smell any engine exhaust. Deadly levels of carbon monoxide can collect rapidly, and you can quickly be overcome and unable to save yourself. Also, deadly levels of carbon monoxide can linger for hours or days in enclosed or poorly ventilated areas. If you experience any symptoms of carbon monoxide poisoning, leave the area immediately, get fresh air, and **SEEK MEDICAL TREATMENT**.

- Do not run engine indoors. Even if you try to ventilate engine exhaust with fans or open windows and doors, carbon monoxide can rapidly reach dangerous levels.
- Do not run engine in poorly ventilated or partially enclosed areas such as barns, garages, or carports. If you start a vehicle in one of these, drive it out and close the door as soon as possible. If you drive it into one of these, turn it off as soon as possible.
- Do not run engine outdoors where engine exhaust can be drawn into a building through openings such as windows and doors.

SAFETY LABELS AND LOCATIONS

Warning labels have been placed on the vehicle for your protection. Read and follow the instructions of the labels on the vehicle carefully. If any of the labels depicted in this manual differ from the labels on your vehicle, always read and follow the instructions of the labels *on the vehicle*.

If any label becomes illegible or comes off, contact your POLARIS dealer to purchase a replacement. Replacement *safety* labels are provided by POLARIS at no charge. The part number is printed on the label.

PROPER USE WARNING (7182649)

The Proper Use Warning ① is located on the center console.

Require Proper Use of Your Vehicle

Do your part to prevent injuries:

- Do not allow careless or reckless driving.
- Make sure operators are 16 or older with a valid driver's license.
- Do not let people drive or ride after using alcohol or drugs.
- Do not allow operation on public roads (unless designated for off-highway vehicle access) - collisions with cars and trucks can occur.
- Do not exceed seating capacity: 2 occupants

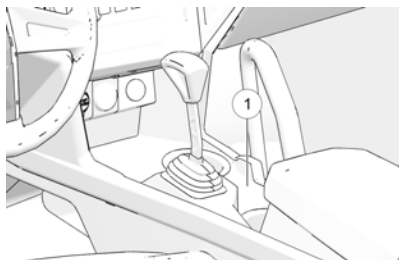

PAYLOAD WARNING / SHIFT CAUTION (7185784)

The Payload/Shift Caution safety label is located on the center console.

WARNING

POLARIS	NEVER EXCEED	IF TOTAL PAYLOAD EXCEEDS
GENERAL	43 MPH (69 kph)	430 lbs. (195 kg)
GENERAL 4	50 MPH (80 kph)	645 lbs. (292 kg)

CAUTION

To avoid transmission damage, shift only when vehicle is stationary and at idle. When vehicle is stopped, place shift in parked position.

SAFETY

SEAT BELT/DRIVE RESPONSIBLY WARNING (7185097)

WARNING

Improper vehicle use can result in SEVERE INJURY or DEATH

BE PREPARED

- Fasten seat belts.
- Wear an approved helmet and protective gear.
- ALWAYS use cab nets and/or doors.
- Each rider must be able to sit with back against seat, feet flat on the floor, and hands on steering wheel or hand holds. Stay completely inside the vehicle.

Drive Responsibly

Avoid loss of control and rollovers:

- Avoid abrupt maneuvers, sideways sliding, skidding or fishtailing, and never do donuts.
- Slow down before entering a turn.
- Avoid hard acceleration when turning, even from a stop.
- Plan for hills, rough terrain, ruts and other changes in traction and terrain. Avoid paved surfaces.
- Avoid sidehilling (riding across slopes).

Be Sure Riders Pay Attention and Plan Ahead

If you think or feel the vehicle may tip or roll, reduce your risk of injury:

- Keep a firm grip on the steering wheel or hand holds and brace yourself.
- Do not put any part of your body outside of the vehicle for any reason.

Rollovers have caused severe injuries and death, even on flat, open areas.

FUEL TRANSPORT WARNING (7186122)

The Fuel Transport Warning is located in the cargo box.

WARNING

NEVER carry fuel or other flammable liquids on this vehicle. Failure to follow this instruction could lead to serious burn injuries or death.

CLUTCH COVER WARNING (7177469)

The clutch cover warning ① is located on the clutch cover.

WARNING

Improper service or maintenance of this PVT system can result in vehicle damage, SEVERE INJURY or DEATH.

Always look for and remove debris inside and around clutch and vent system when replacing belt.

Read owner's manual or see authorized POLARIS dealer.

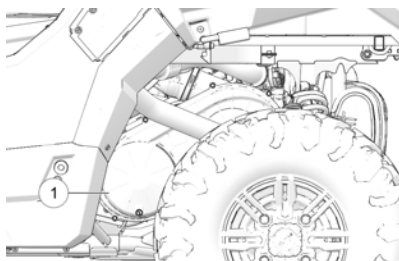

SAFETY

LOAD / PASSENGER / TIRE PRESSURE WARNING

The Load/Passenger/Tire Pressure warning decal is located on the front panel of the rear cargo box ①.

WARNING

- Never carry passengers in cargo box.
- Passengers can be thrown off. This can cause serious injury or death.

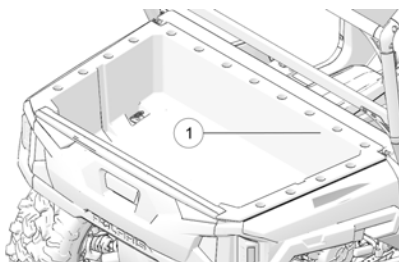

IMPROPER TIRE PRESSURE OR OVERLOADING CAN CAUSE LOSS OF CONTROL RESULTING IN SERIOUS INJURY OR DEATH.

- Reduce speed and allow greater distance for braking when carrying cargo.
- Overloading or carrying tall, off-center, or unsecured loads will increase your risk of losing control. Loads should be centered and carried as low as possible in box.
- For stability on rough or hilly terrain, reduce speed and cargo.
- Be careful if load extends over the side of the box.

GENERAL	GENERAL SPORT	GENERAL PREM	GENERAL XP	GENERAL XP 4
MAXIMUM CARGO BOX LOAD	600 lbs. (272 Kg)	600 lbs. (272 Kg)	600 lbs. (272 Kg)	600 lbs. (272 Kg)
TIRE PRESSURE IN PSI (KPa)	FRONT 10 (69) REAR 18 (125)	FRONT 12 (87) REAR 14 (96)	FRONT 10 (69) REAR 14 (97)	FRONT 16 (110) REAR 22 (152)
MAXIMUM WEIGHT CAPACITY INCLUDES WEIGHT OF OPERATOR, PASSENGERS, CARGO, AND ACCESSORIES	1030 lbs. (467 Kg)	1030 lbs. (467 Kg)	1000 lbs. (454 kg)	1280 lbs. (581 kg)
Read Operation and Maintenance Manual for more detailed loading information.				

Part number: 7300876 (English), 7300876-F (French-Canadian)

AIR FILTER CAUTION

The Air Filter Caution label is located on the air filter housing.

CAUTION

Use a Polaris approved air filter. The use of a non-Polaris approved air filter may cause engine damage. Before installing filter, ensure there is no dirt or debris in the clean side of the intake tube. The air filter must be properly seated before the lid is reinstalled. Please reference your owner's manual for additional information regarding air filter service.

Part Number 7182652 (English), 7182652-F (French Canadian)

INTAKE DUCT CAUTION (7182087)

CAUTION

Air intake tube must be fully seated on air box and throttle body. Inspect full perimeter if serviced. Clamps at air box and throttle body must be torqued to 49 in-lbs (5.5 N-m) or severe engine damage may occur.

FEATURES AND CONTROLS

COMPONENT LOCATIONS

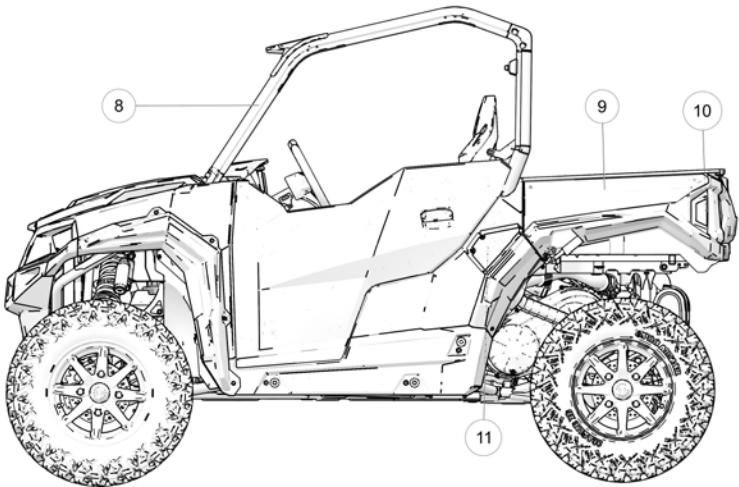
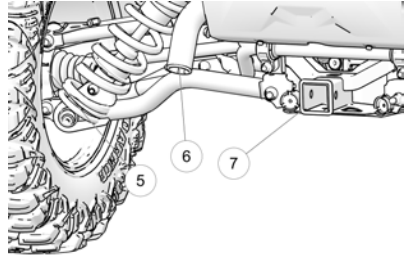

- ① Console
- ② Headlights
- ③ Radiator
- ④ Front Bumper/ Brush Guard/Lighted Bar (if equipped)
- ⑤ CV Boot/Rear Caliper
- ⑥ Muffler (Spark Arrester)
- ⑦ Receiver Hitch
- ⑧ ROPS Cab Frame
- ⑨ Cargo Box
- ⑩ Taillights
- ⑪ PVT Intake Screen

FEATURES AND CONTROLS

GEAR SELECTOR

Low gear is the primary driving range for your vehicle. High gear is intended for use on hard-packed surfaces with light loads. Using high gear for heavy loads, hilly terrain or in wet, muddy conditions will increase the chance of drive belt burning. See the Drive Belt Wear/Burn section on page 111.

To shift gears, brake to a complete stop. When the engine is idling, move the lever ① to the desired gear.

H: High Gear
L: Low Gear
N: Neutral
R: Reverse
P: Park



NOTICE

Shifting gears with the engine speed above idle or while the vehicle is moving could cause transmission damage. Always shift when the vehicle is stationary and the engine is at idle.

TIP

Maintaining shift linkage adjustment is important to assure proper transmission function. Your POLARIS dealer, or other qualified person, can assist in resolving any shifting problems.

USING LOW RANGE

Always shift into low gear for any of the following conditions.

- Operating in rough terrain or over obstacles
- Loading the vehicle onto a trailer
- Towing loads
- Driving frequently at low RPM or at ground speeds below 7 MPH (11 km/h)

SWITCHES

IGNITION SWITCH

OFF	The engine is off. Electrical circuits are off, except Acc, 12V.
ACCESSORY (if equipped)	The engine is off. Powers the gauge and terminal block. Check engine and steering warning indicators will appear on the gauge in this mode, but will turn off when the vehicle is started if no issues are present.
ON	Electrical circuits are on. Electrical equipment can be used.
START	Turn the key to the START position to engage the electric starter. The key returns to the ON position when released.

The ignition switch ① is a four-position, key-operated switch. The key can be removed from the switch when it is in the OFF position.



AWD/DIFFERENTIAL LOCK SWITCH

The AWD switch has three positions:

- All Wheel Drive (AWD)
- Two Wheel Drive (2WD)
- Differential Unlock (TURF mode)

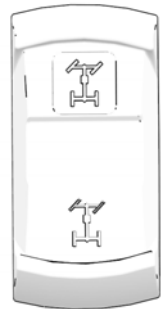

FEATURES AND CONTROLS

LIGHT SWITCH

The ignition switch key must be in the ON/RUN position to operate the headlights. Press the top of the switch to place the headlights on high beam. Move the switch to the center position to place the headlights on low beam. Press the bottom of the switch to turn off the headlights.

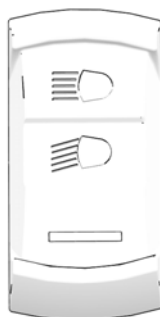

WINCH SWITCH (IF EQUIPPED)

Press the top of the rocker switch to spool line out from the winch. Press the bottom of the rocker switch to spool line in to the winch. Move the rocker switch to the center position to stop spooling.



BUMPER-MOUNTED LIGHT BAR SWITCH (IF EQUIPPED)

NOTICE

The bumper-mounted light bar should only be used when operating off-road.

To activate the bumper-mounted light bar, the ignition switch must be in the ACC or ON position. Press the top of the rocker switch to activate the bumper-mounted light bar.



AUXILIARY OUTLET

The vehicle is equipped with a 12-volt accessory outlet in the dash. Use the outlet to power an auxiliary light or other optional accessories.



FOOT PEDALS

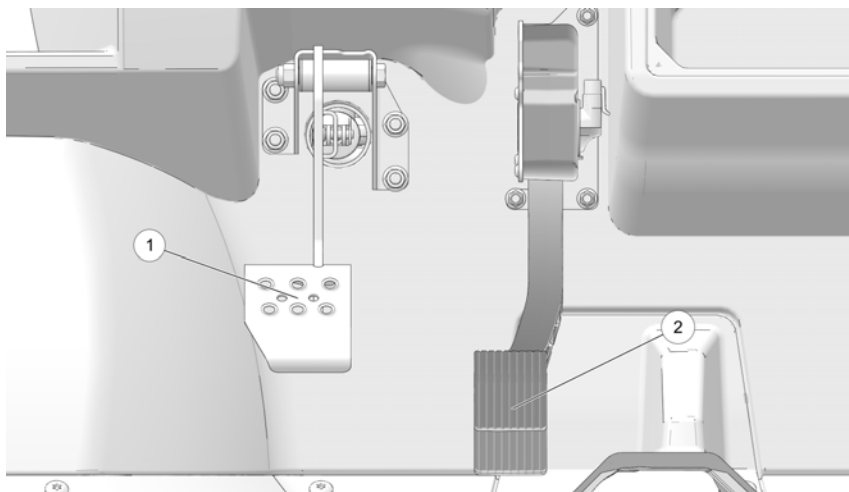

BRAKE PEDAL

Depress the brake pedal ① to slow or stop the vehicle. Apply the brakes while starting the engine.

When the brake pedal is depressed, the brake light comes on. Check the brake light before each ride.

1. Turn the ignition switch to the ON position.
2. Apply the brakes. The brake light should come on after about 10 mm (0.4 in.) of pedal travel.

THROTTLE PEDAL

Push the throttle pedal ② down to increase engine speed. Spring pressure returns the pedal to the rest position when released. Always check that the throttle pedal returns normally before starting the engine.

TIP

If the throttle pedal and brake pedal are applied simultaneously, engine power may be limited.

SEATS

SEAT BELTS

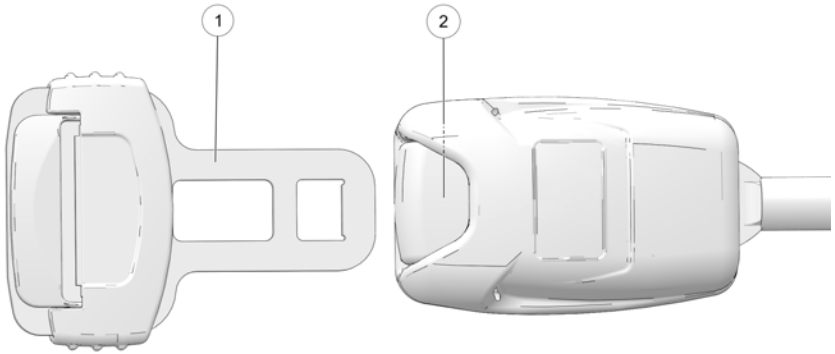

This vehicle is equipped with three-point lap and diagonal seat belts for the operator and any passengers. Always make sure the seat belts are secured for all riders before operating. The driver's seat belt is equipped with a seat belt interlock. Vehicle speed will be limited to 15 MPH (24 km/h) if the seat belt is not secured.

WARNING

Falling from a moving vehicle could result in serious injury or death. Always fasten your seat belt securely before operating or riding in the vehicle.

To wear the seat belt properly, follow this procedure:

1. For 3-point belts, pull the seat belt latch ① downward and across your chest toward the buckle at the inner edge of the seat. The belt should fit snugly across your hips and diagonally across your chest. Make sure the belt is not twisted.
2. Push the latch plate ① into the buckle ② until it clicks.
3. Release the strap, it will self tighten.
4. To release the seat belt, press the square red button in the buckle's center.

FEATURES AND CONTROLS

SEAT BELT INSPECTION



Failure to perform regular inspection can reduce the effectiveness of the seat belt during a crash and could result in serious injury or death.

Inspect all seat belts for proper operation before each use of the vehicle.

1. Push the latch plate into the buckle until it clicks. The latch plate must slide smoothly into the buckle. A click indicates that it's securely latched.
2. Push the red release latch in the middle of the buckle to make sure it releases freely.
3. Pull each seat belt completely out and inspect the full length for any damage, including cuts, wear, fraying or stiffness. If any damage is found, or if the seat belt does not operate properly, have the seat belt system checked and/or replaced by an authorized dealer.
4. To clean dirt or debris from the seat belts, sponge the straps with mild soap and water. Do not use bleach, dye or household detergents. Rinse the entire length of the belt webbing. Use a garden hose to flush out the retractor and latch housings regularly.

SEAT AND STORAGE COMPARTMENTS

A small storage compartment is located between the driver's seat and passenger's seat ①.

If your model is equipped with a storage console and cup holders located between the seats, lift the console lid to access the storage compartment.

The ECU is located in the compartment behind the driver's seat. Do not use this area for storage.

The electrical compartment is located under the driver's seat. Never use the electrical compartment for storage.

Remove the driver's seat to access the battery and fuse box.

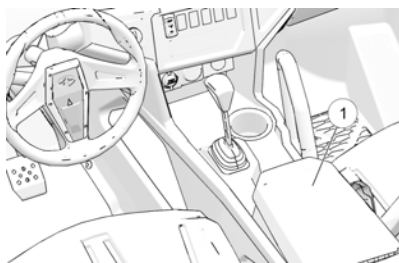

SEAT REMOVAL AND COMPARTMENT ACCESS

Pull the rear edge of a seat upward to release the latch pins from the grommets. Roll the seat forward to access the under-seat area. To completely remove a seat, roll the seat forward and lift the seat tabs from the seat base mounts.

Always make sure all seats are properly installed and securely latched before operating. Push down firmly on the rear of each seat until the latch pins are fully seated into the grommets.

ELECTRONIC POWER STEERING (IF EQUIPPED)

Electronic power steering (EPS) engages when the ignition key is turned to the ON position. EPS remains engaged whether the vehicle is moving or idle. To conserve battery power, the EPS will shut down 5 minutes after the engine is stopped if the key remains in the ON position. The EPS warning indicator will illuminate to indicate the EPS has shut down. Turn the key off and on to reset the unit. If the light remains on after starting the engine, the EPS system is inoperative. See your POLARIS dealer, or other qualified person, as soon as possible for repair. Continued operation could result in permanent damage to the EPS unit and increased steering effort.

ADJUSTABLE STEERING WHEEL

The steering wheel can be tilted upward or downward for rider preference.

Lift and hold the adjustment lever while moving the steering wheel upward or downward. Release the lever when the steering wheel is at the desired position.

ROLLOVER PROTECTIVE STRUCTURE (ROPS)

The Rollover Protective Structure (ROPS) on this vehicle meets OSHA® 1928.53/ ISO 3471:2008 performance requirements. Always have your authorized dealer thoroughly inspect the ROPS if it ever becomes damaged in any way.

No device can assure occupant protection in the event of a rollover. Always follow all safe operating practices outlined in this manual to avoid vehicle rollover.



Vehicle rollover could cause severe injury or death. Always avoid operating in a manner that could result in vehicle rollover.

TRAILER HITCH BRACKET

This vehicle is equipped with a receiver hitch bracket for a trailer hitch. A hitch capacity label is located on the hitch.

To avoid injury and property damage, always heed the warnings and towing capacities outlined on page 59.

FEATURES AND CONTROLS

CAB DOORS

This vehicle is equipped with cab doors. Riding in this vehicle without closed and latched cab doors increases the risk of serious injury or death in the event of an accident or rollover. Always make sure all cab doors are closed and latched when riding in this vehicle.

Always inspect doors and latches for wear and damage before each use of the vehicle. Promptly replace any worn or damaged parts with new parts available from your authorized POLARIS dealer, or other qualified person.

FUEL CAP

NOTICE

Never use fuel blends with more than 10% ethanol. Engine damage could occur.

The fuel tank filler cap ① is located on the right side of the vehicle near the passenger seat. Use only unleaded gasoline with a minimum pump octane number of 87 R+M/2 octane (equivalent to 95 RON in Europe). Unleaded fuel blends with up to 10% ethanol can be used.

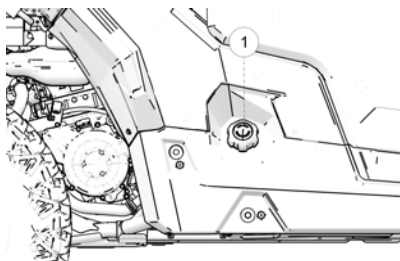

HOOD

Remove the hood to access the radiator pressure cap and coolant overflow bottle.

CAUTION

Escaping steam can cause burns. Never remove the pressure cap while the engine is warm or hot. Always allow the engine to cool before removing the pressure cap.

To remove the hood, do the following:

1. Turn the hood fasteners ② 1/4 turn.
2. Grasp the upper hood edge and pull upward to disengage the fasteners.
3. Pivot the hood forward and lift upward to disengage the lower hood hooks.
4. Lift the hood away from the vehicle.

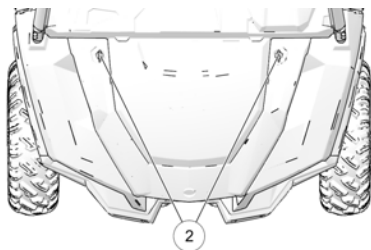

INSTRUMENT CLUSTER

NOTICE

High water pressure may damage components. Wash the vehicle by hand or with a garden hose using mild soap. Certain products, including insect repellents and chemicals, will damage the speedometer lens and other plastic surfaces. Do not use alcohol to clean the instrument cluster. Do not allow insect sprays to contact the lens. Immediately clean off any gasoline that splashes on the instrument cluster.



- ① Speedometer
- ② Tachometer
- ③ Indicator Lamps

- ④ Mode Button
- ⑤ Toggle Buttons
- ⑥ Rider Information Center

FEATURES AND CONTROLS

SPEEDOMETER

The speedometer displays vehicle speed in either miles per hour (MPH) or kilometers per hour (km/h).

TACHOMETER

The tachometer displays engine speed in revolutions per minute (RPM).

MODE BUTTON

Press and hold the MODE button ④ to enter or exit the settings menu. Press and release the MODE button to cycle through Area 1 modes and to select an item.









TOGGLE BUTTONS

Press and release either toggle button ⑤ to cycle through the options menu or Area 2 modes. Press and hold either toggle button to reset an item. See page 48.

TIP

With the ignition key off, pressing the MODE button or either toggle button will power up the Rider Information Center for 10 seconds to allow viewing of the odometer and the clock.

INDICATOR LAMPS

LAMP	INDICATES	CONDITION
MPH	Vehicle Speed	When standard mode is selected, speed displays in miles per hour.
km/h		When metric mode is selected, speed displays in kilometers per hour.
	Over Temperature	This lamp illuminates to indicate an overheated engine. If the indicator flashes, the overheating condition remains, and the system will automatically reduce engine power.
	Electric Power Steering (EPS) Warning (if equipped)	This indicator illuminates briefly when the key is turned to the ON position. If the light remains on, the EPS system is inoperative. See your POLARIS dealer, or other qualified person, as soon as possible for repair. Continued operation could result in permanent damage to the EPS unit and increased steering effort.
N	Neutral	This lamp illuminates when the transmission is in neutral and the ignition key is in the ON position.
	High Beam	This lamp illuminates when the headlamp switch is set to high beam.
	Helmet/Seat Belt	This lamp is a reminder to the operator to ensure all riders are wearing helmets and seat belts before operating. The driver's seat belt is equipped with a seat belt interlock. Vehicle speed will be limited to 15 MPH (24 km/h) if the seat belt is not secured.
	Check Engine	This indicator appears if an Electronic Fuel Injection (EFI) related fault occurs. Do not operate the vehicle if this warning appears. Serious engine damage could result. Your authorized dealer or qualified person can assist.
	Check Battery	This warning usually indicates that the vehicle is operating at an RPM too low to keep the battery charged. It may also occur when the engine is at idle and high electrical load (lights, cooling fan, accessories) is applied. Drive at a higher RPM or recharge the battery to clear the warning.
	Low Fuel	This lamp illuminates when fuel level in the fuel tank is low.
	Speed Key (optional accessory)	Information about the speed key is provided in the accessory kit.

FEATURES AND CONTROLS

RIDER INFORMATION CENTER

①	Gear Indicator	This indicator displays gear shifter position. H = High Gear L = Low Gear N = Neutral R = Reverse Gear P = Park – = Gear Signal Error (or shifter between gears)
②	AWD Indicator	This indicator shows whether 2X4 or AWD is active.
③	Service Indicator	A flashing wrench symbol alerts the operator that the preset service interval has been reached. Your POLARIS dealer, or other qualified person, can provide scheduled maintenance. See page 51 for resetting instructions.
④	Fuel Gauge	The segments of the fuel gauge show the level of fuel in the fuel tank. When the last segment clears, a low fuel warning is activated. The outline of the fuel display will flash. Refuel immediately.
⑤	Speed Limitation (if equipped)	This vehicle may be equipped with a maximum speed limitation function. This would be displayed on the screen as “LIM” followed by the speed. “LIM 30” for example.

The rider information center is located in the instrument cluster. All segments will light up for one second at start-up.

If the instrument cluster fails to illuminate, a battery over-voltage may have occurred and the instrument cluster may have shut off to protect the electronic speedometer. If this occurs, your POLARIS dealer, or other qualified person, can provide proper diagnosis.

The information center is set to display standard units of measurement and a 12-hour clock at the factory. To change to metric and/or a 24-hour clock hold the mode button and cycle to the clock menu. Use the directional arrows to change the clock settings.

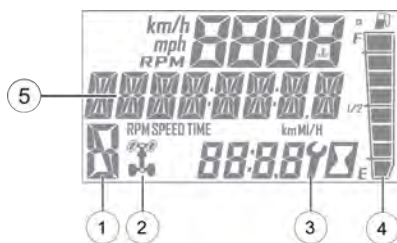

MODE INFORMATION DISPLAYS

The rider information center contains three areas that display mode information.

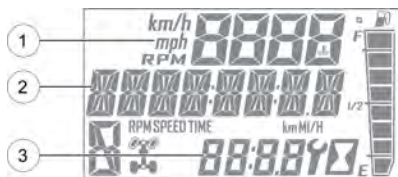

① Area 1 Modes	Description
Engine Temperature	Temperature of engine coolant
Vehicle Speed	Speed of vehicle
Tachometer	Engine speed (RPM)
② Area 2 Modes	Description
Odometer	The odometer records and displays the distance traveled by the vehicle.
Trip Meters (T1/T2)	A trip meter records the distance traveled by the vehicle if reset before each trip. To reset, see page 50.
Engine Hours	Total hours of engine operation since manufacture
Service Hours	A flashing wrench symbol indicates that the preset service interval has been reached. To reset, see page 51.
Trip Time	Time length of vehicle operation since mode was last reset
③ Area 3 Modes	Description
Clock	The clock displays time in a 12-hour or 24-hour format. To reset, see page 49.

FEATURES AND CONTROLS

ACCESSING MENUS AND OPTIONS

GAUGE SETTINGS MENU

Press and release the MODE button to cycle through the Area 1 modes until the desired default mode displays. See the Mode Information Displays section for details.

Press and hold the MODE button to enter the settings menu.

The OPTIONS screen will display for a few seconds.

1. Press and release either toggle button to cycle to the desired option.
2. Press MODE to select the option.
3. Press either toggle button to cycle to the desired setting.
4. Press MODE to save and exit to the settings menu.
5. Press and hold the MODE button to exit the settings menu.



BACKLIGHT COLOR

The information center backlight can be set to either blue or red.

1. Press and hold the MODE button to enter the settings menu.
2. Press either toggle button to cycle to the "BL COLOR" option. Press MODE to select.
3. Press either toggle button to cycle to the desired setting.
4. Press MODE to save and exit to the settings menu,



BACKLIGHT BRIGHTNESS

The information center backlight can be set to either blue or red.

1. Press and hold the MODE button to enter the settings menu.
2. Press either toggle button to cycle to the "BL LEVEL" option. Press MODE to select.
3. Press "UP" button to increase brightness. Press "DOWN" button to decrease brightness.
4. Press MODE to select and exit to the settings menu.



CLOCK

The clock must be reset any time the battery has been disconnected or discharged.

1. Press and hold the MODE button to enter the settings menu.
2. Press either toggle button to cycle to the "CLOCK" option. Press MODE to select.
3. Press either toggle button to cycle to the desired setting (12H or 24H). Press MODE to select.
4. Press either toggle button to change each segment of the clock. Press MODE to accept a change and advance to the next segment.



FEATURES AND CONTROLS

DISPLAY UNITS (STANDARD/METRIC)



1. Press and hold the MODE button to enter the settings menu.
2. Press either toggle button to cycle to the desired “UNITS” option (distance, temperature or volume). Press MODE to select.
3. Press either toggle button to cycle to the desired setting.
4. Press MODE to save and exit to the settings menu.

TRIP METER

Use a trip meter to track the distance traveled during a specific trip or period of time. Reset the meter to zero before traveling.

1. Press either toggle button to cycle to the desired trip meter option (T1 or T2).
2. Press and hold either toggle button until the meter resets to zero.



TRIP TIME

Use a trip time meter to track the travel time during a specific trip. Reset the meter to zero before traveling.

1. Press either toggle button to cycle to the trip time option (TT).
2. Press and hold either toggle button until the meter resets to zero.



PROGRAMMABLE SERVICE INTERVAL

The service interval counter is programmed to 25 hours at the factory. As hours of engine operation increase, the counter decreases. The wrench icon will flash for about 10 seconds when the counter reaches zero (0), and each time the key is turned on thereafter, until the counter is reset.

When this feature is enabled, it provides a convenient reminder to perform routine maintenance. Refer to the Periodic Maintenance Chart for recommended service intervals.

Use the following procedure to reset or change the service interval.

1. Press and hold the MODE button to enter the settings menu.
2. Press either toggle button to cycle to the "Service Hours" option. Press MODE to select.
3. Press MODE to reset the existing value and exit, or press either toggle button to change the value. Press MODE to save and exit to the settings menu.



FEATURES AND CONTROLS

ENGINE ERROR CODES

The error screen displays only when the CHECK ENGINE indicator is on or when it goes on and off during one ignition cycle. Error codes are not stored. When the key is turned OFF, the code and message is lost, but will reappear if the fault reoccurs after restarting the engine.

If the CHECK ENGINE lamp or the EPS lamp illuminates, retrieve the active error codes from the display.

- ① Failure Mode Indicator (FMI)
- ② Suspect Parameter Number (SPN)
- ③ Code Count

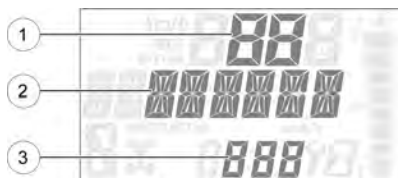

1. Press and hold the MODE button to enter the settings menu.
2. Press either toggle button to cycle to the "DIAGCODE" option. Press MODE to select.
3. More than one diagnostic code may be present. Press the toggle UP button to see if more codes are present. Press MODE to select a code.

NOTICE

If the displayed code is an engine fault code, the CHECK ENGINE lamp will blink. If the displayed code is an EPS fault code, the EPS lamp will blink.

4. Record the three (3) numbers displayed.
5. Press MODE to exit to the settings menu.

OPERATION

SAFETY WARNINGS

 **WARNING**

Failure to operate this vehicle properly can result in a collision, loss of control, accident or rollover, which may result in serious injury or death. Heed all safety warnings outlined in this section of the owner's manual and in the safety DVD provided with your vehicle. See the OPERATION section of the owner's manual for proper operating procedures.

VEHICLE BREAK-IN PERIOD

The break-in period for your new vehicle is the first 25 hours of operation, or the time it takes to use the first 2 full tanks of gasoline. No single action on your part is as important as a proper break-in period. Careful treatment of a new engine will result in more efficient performance and longer life for the engine. Perform the following procedures carefully.

 **NOTICE**

Excessive heat build-up during the first 3 hours of operation will damage close-fitted engine parts and drive components. Do not operate at full throttle or high speeds during the first 3 hours of use.

ENGINE AND DRIVETRAIN BREAK-IN

1. Fill the fuel tank with clean, fresh fuel. Review the fuel warnings in the Refueling section.
2. Check the oil level. Add the recommended oil as needed to maintain the oil level in the normal (safe) operating range.
3. Drive slowly at first. Select an open area that allows room to familiarize yourself with vehicle operation and handling.
4. Vary throttle positions. Do not operate at sustained idle.
5. Perform regular checks on fluid levels, controls and areas outlined on the daily pre-ride inspection checklist.

During the break-in period, change both the oil and the filter at 25 hours.

6. Check fluid levels of transmission and all gearcases after the first 25 hours of operation and every 100 hours thereafter.
7. Pull only light loads.

OPERATION

PVT BREAK-IN (CLUTCHES/BELT)

Always break in the clutches and drive belt of new vehicles, as well as after a belt replacement.

A proper break-in of the clutches and drive belt will ensure a longer life and better performance. Break in the clutches and belt by operating at slower speeds during the break-in period as recommended. Pull only light loads. Avoid aggressive acceleration and high speed operation during the break-in period.

If a belt fails, always clean any debris from the PVT intake and outlet duct and from the clutch and engine compartments when replacing the belt.

FUEL RECOMMENDATION

Polaris recommends using fresh Unleaded 87 Octane TOP TIER DETERGENT GASOLINE® containing up to 10% ethanol purchased during the season of vehicle usage. This fuel will provide the best engine performance (starting, run quality, fuel economy, and power) and durability.

Octane Rating

Polaris recommends a minimum of 87 Octane (R+M/2) rated gasoline. Using lower octane gasoline could result in engine damage.

Ethanol Content

Polaris recommends gasoline containing up to 10% ethanol (E10). Higher levels of ethanol (ex. E15 and E85) may result in engine damage.

Detergent Gasoline

Polaris recommends TOP TIER DETERGENT GASOLINE® to keep the engine cleaner by reducing carbon deposits, which will help maintain engine performance and durability. Refer to www.toptiergas.com for a list of TOP TIER DETERGENT GASOLINE® retailers. Alternatively, the logo shown below on the retailer's fuel pump will confirm that TOP TIER DETERGENT GASOLINE® is being dispensed.



If TOP TIER DETERGENT GASOLINE® is not available, adding Polaris Carbon Clean to the fuel tank at every oil change will help reduce carbon deposits.

Seasonal Blends

Polaris recommends using gasoline that is purchased during the season the vehicle is being used, especially summer vs. winter. Between seasons, refineries typically change the gasoline blend to avoid temperature induced engine performance issues. Winter blend gasoline improves engine starting in cold weather and summer blend gasoline helps prevent vapor lock issues in hot weather.

STARTING THE ENGINE

1. Position the vehicle on a level surface outdoors or in a well ventilated area.
2. Sit in the driver's seat and fasten the seat belt. Secure the cab doors (if equipped).
3. Place the transmission in PARK.
4. Apply the brakes. Do not press the throttle pedal while starting the engine.
5. Turn the ignition key past the ON/RUN position to START. Engage the starter for a maximum of five seconds. Release the key when the engine starts.
6. If the engine does not start within five seconds, return the ignition switch to the OFF position and wait five seconds. Repeat steps 5 and 6 until the engine starts.
7. Vary the engine RPM slightly with the throttle to aid in warm up until the engine idles smoothly.

NOTICE

Operating the vehicle immediately after starting could cause engine damage. Allow the engine to warm up for several minutes before operating the vehicle.

OPERATION

STOPPING THE ENGINE

1. Release the throttle pedal completely and brake to a complete stop.
2. Place the transmission in PARK.
3. Turn the key to the OFF position.
4. Slowly release the brake pedal and make sure the transmission is in PARK before exiting the vehicle.



A rolling vehicle can cause serious injury. Always place the transmission in PARK before stopping the engine.

BRAKING

1. Release the throttle pedal completely.

 **NOTICE**

When the throttle pedal is released completely and engine speed slows to near idle, the vehicle has no engine braking.

2. Press on the brake pedal evenly and firmly. Practice starting and stopping (using the brakes) until you're familiar with the controls.

ALL WHEEL DRIVE/REAR DIFFERENTIAL SYSTEM (AWD)

If your model is equipped with a lockable differential, you can choose to operate with an open differential or a closed differential.

ENGAGING AWD

Press the top of the switch to engage All Wheel Drive (AWD). The 4X4 indicator illuminates in the rider information center to indicate that the vehicle is in AWD.

When the AWD switch is on, the front gearcase will automatically engage any time the rear wheels lose traction. When the rear wheels regain traction, the front gearcase will automatically disengage. There is no limit to the length of time the vehicle may remain in AWD.

Initially, the vehicle's electronic system will not enable the AWD until the engine RPM is below 3100. Once enabled, the AWD remains enabled until the AWD switch is turned off. If the switch is turned off while the front gearcase is moving, it will not disengage until the rear wheels regain traction.

- ① All-Wheel Drive (AWD)
- ② Differential Lock
- ③ Differential Unlock

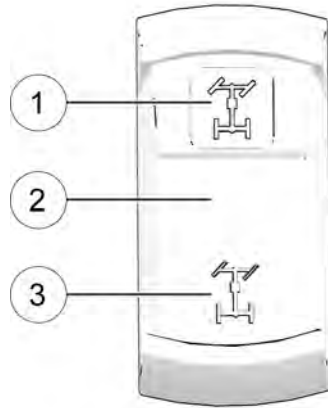

Engage the AWD before getting into conditions where front wheel drive may be needed. If the rear wheels are spinning, release the throttle before switching to AWD.

NOTICE

Switching to AWD while the rear wheels are spinning may cause severe drive shaft and clutch damage. Always switch to AWD while the rear wheels have traction or are at rest.

DISENGAGING AWD

Move the AWD switch to the center or bottom position to disengage AWD. If the switch is turned off while the front hubs are driving, they will not release until the rear wheels regain traction.

In some situations, the front gearcase may remain locked after turning the AWD switch off. If this occurs, you may notice increased steering effort and some vehicle speed restriction. Perform the following procedure to unlock the front gearcase.

To disengage AWD, do the following:

1. Stop the vehicle.
2. Operate in reverse for at least 10 feet (3 m).
3. Stop completely.
4. Shift into low gear and drive forward.
5. If the front gearcase remains locked after following these instructions, see your dealer or other qualified service person for service.

OPERATION

LOCKING THE DIFFERENTIAL

Move the rocker switch to the center position to lock the differential and operate in two wheel drive (2WD). Locking the differential in slippery or low traction conditions helps improve traction. When the rear differential is locked, both rear wheels rotate at the same speed.

UNLOCKING THE DIFFERENTIAL (TURF MODE)

When operating in TURF mode, the inside rear wheel will rotate independently from the outside wheel during turns. Operate in TURF mode only as needed to protect smooth, level surfaces from tire damage. DO NOT operate in TURF mode when climbing or descending hills, when sidehilling, or when operating on uneven, loose, or slippery terrain such as sand, gravel, ice, snow, obstacles, and water crossings. Always operate in AWD on these types of terrain.

WARNING

Operating in TURF mode (if equipped) when on sloped, uneven, or loose terrain could cause loss of control and result in serious injury or death. One rear wheel may slip and lose traction or may lift up and grab when it touches the ground again.

Press the bottom of the switch to unlock the differential and allow the rear drive wheels to operate independently (1WD). When the rear differential is unlocked, the rear wheels can rotate at different speeds. Unlock the differential to make maneuvering easier and minimize damage to turf.

NOTICE

Damage to the differential can occur if it is engaged while the vehicle is traveling at high speeds or while the rear wheels are spinning. Slow the vehicle to nearly stopped before engaging the differential.

WARNING

Never operate in TURF mode (if equipped) while operating on a hill or other irregular terrain. Always move the AWD switch to AWD before ascending or descending a hill.

HAULING CARGO

 **WARNING**

Hauling cargo improperly can alter vehicle handling and may cause loss of control or brake instability, which can result in serious injury or death.

 **WARNING**

Always follow these precautions when hauling cargo:

- Never exceed the maximum weight capacity of the vehicle. When determining the weight you are adding to the vehicle, include the weight of the operator, passengers, non-factory installed accessories, loads in the rack or box and the load on the trailer tongue. The combined weight of these items must not exceed the maximum weight capacity.
- **REDUCE SPEED AND ALLOW GREATER DISTANCES FOR BRAKING WHEN HAULING CARGO.**
- Always load the cargo box with the load as far forward and as low as possible.
- When operating over rough or hilly terrain, reduce speed and cargo to maintain stable driving conditions.
- Always operate the vehicle with extreme care when hauling or towing loads.
- Slow down and drive in the lowest gear available. When transporting heavy loads and/or when towing, always operate the vehicle in low gear.

OPERATION

WARNING

- **SECURE ALL LOADS BEFORE OPERATING.** Unsecured loads can create unstable operating conditions, which could result in loss of control of the vehicle.
- **OPERATE ONLY WITH STABLE AND SAFELY ARRANGED LOADS.** When handling off-centered loads that cannot be centered, securely fasten the load and operate with extra caution. Always attach the tow load to the hitch point designated for your vehicle.
- **HEAVY LOADS CAN CAUSE BRAKING AND CONTROL PROBLEMS.** Use extreme caution when applying brakes with a loaded vehicle. Avoid terrain or situations that may require backing downhill.
- **USE EXTREME CAUTION** when operating with loads that extend over the rack sides. Stability and maneuverability may be adversely affected, causing vehicle rollover.
- **DO NOT TRAVEL FASTER THAN THE RECOMMENDED SPEEDS.** Vehicle should never exceed 10 MPH (16 km/h) while towing a load on a level grass surface. Vehicle speed should never exceed 5 MPH (8 km/h) when towing loads in rough terrain, while cornering, or while ascending or descending an incline.

Your POLARIS vehicle has been designed to carry or tow specific capacities. Always read and understand the load distribution warnings listed on the warning labels. The total load (operator, passengers, non-factory installed accessories, cargo and weight on hitch) must not exceed the maximum weight capacity of the vehicle. See the Safety chapter for details.

WARNING

Driving with passengers in the cargo box can result in severe injury or death. Never allow passengers to ride in the cargo box. Passengers must always ride in the cab with seat belts fastened securely.

TOWING LOADS

Towing improperly can alter vehicle handling and may cause loss of control or brake instability. Always follow these precautions when towing:

1. Never load more than 150 lbs. (68.1 kg) tongue weight on the towing bracket.
2. When transporting heavy loads and/or when towing, always operate the vehicle in low gear.
3. Do not operate the vehicle faster than 10 MPH (16 km/h) when towing. Towing a trailer increases braking distance.

4. Do not tow more than the recommended weight for the vehicle. See the towing capacity chart below and the Specifications section for towing values.
5. Attach a trailer to the trailer hitch bracket only. Do not attach a trailer to any other location, which could result in loss of control of the vehicle.
6. Avoid towing loads on an incline. If it's unavoidable, choose the smallest incline available, operate with extreme caution, and drive straight up or down the incline.

TOTAL TOWED LOAD WEIGHT (LEVEL GROUND)	TOTAL HITCH VERTICAL WEIGHT	MAXIMUM TOWING SPEED
2000 lbs. (907 kg)	150 lbs. (68.1 kg)	10 MPH (16 km/h)

NOTE

To extend belt life, use low gear when hauling or towing heavy cargo.

OPERATION

BELT LIFE

To extend belt life, use low gear when hauling or towing heavy cargo.

DUMPING THE CARGO BOX

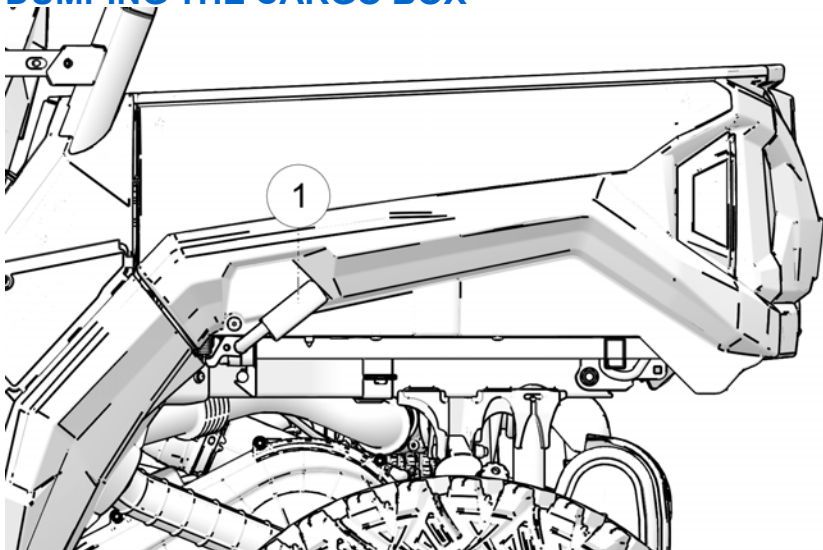

1. Select a level site to dump the cargo box. Do not attempt to dump or unload the vehicle while parked on an incline.
2. Apply the brakes. Place the transmission in PARK.
3. Ensure that the cargo is positioned evenly or toward the front of the cargo box.
4. Release the tailgate by pulling up on the tailgate latch.

WARNING

If the weight distribution on the box is located toward the rear of the box when the release lever is pulled forward, the box may dump unexpectedly and cause serious injury to the operator or bystanders. Never operate the dump lever without ensuring that the load is positioned evenly or at the front of the box.

5. Stand clear and pull one of the cargo box release levers upward. Lift the front of the cargo box to dump the cargo.
6. Lower the cargo box and push down securely to latch.

 **WARNING**

Operating the vehicle while the cargo box is raised could result in severe injury. The box could close unexpectedly and cause injury to the driver or passenger. The rear tires could also catch the rear of a raised box, damaging the vehicle and creating hazardous driving conditions. Never operate this vehicle with the cargo box in the raised position.

TOWING THE GENERAL

Towing this vehicle is not recommended. Always transport the vehicle on a trailer or flatbed with all four wheels off the ground. See the Transporting the General section for details.

If towing a disabled vehicle is unavoidable, place the disabled vehicle's transmission in neutral. Tow the shortest distance possible. Do not operate faster than 10 MPH (16 km/h).

EMISSION CONTROL SYSTEMS

NOISE EMISSION CONTROL SYSTEM

Do not modify the engine, intake or exhaust components, as doing so may affect compliance with U.S.A. EPA noise control requirements (40 CFR 205) and local noise level requirements.

OPERATION ON PUBLIC LANDS IN THE U.S.A.

Your vehicle has a spark arrester that was tested and qualified to be in accordance with the USFS standard 5100-1D. Federal law requires that this spark arrester be installed and functional when the vehicle is operated on public lands.

Operation of off-road vehicles on public lands in the U.S.A. is regulated by 43 CFR 420. Violations are subject to monetary penalties. Federal regulations can be viewed online at <https://ecfr.federalregister.gov/current/title-43/subtitle-B/chapter-1/part-420>.

CRANKCASE EMISSION CONTROL SYSTEM

This engine is equipped with a closed crankcase system. Blow-by gases are forced back to the combustion chamber by the intake system. All exhaust gases exit through the exhaust system.

EXHAUST EMISSION CONTROL SYSTEM

Exhaust emissions are controlled by engine design. An electronic fuel injection (EFI) system controls fuel delivery. The engine and EFI components are set at the factory for optimal performance and are not adjustable.

The emissions label is located on the inside of the lower left frame tube (below driver's foot area).

ELECTROMAGNETIC INTERFERENCE

This spark ignition system complies with Canadian ICES-002.

This vehicle complies with the EMC requirements of UN ECE Regulation 10.

Non-ionizing Radiation: This vehicle emits some electromagnetic energy. People with active or non-active implantable medical devices (such as heart monitoring or controlling devices) should review the limitations of their device and the applicable electromagnetic standards and directives that apply to this vehicle.

MAINTENANCE

PERIODIC MAINTENANCE CHART

Any qualified repair shop or person may maintain, replace or repair the emission control devices or systems on your vehicle. An authorized dealer can perform any service that may be necessary for your vehicle. POLARIS also recommends POLARIS parts for emissions-related service, however equivalent parts can be used.

It is a potential violation of the Clean Air Act if a part supplied by an aftermarket parts manufacturer reduces the effectiveness of the vehicle's emission controls. Tampering with emission controls is prohibited by federal law.

Owners are responsible for performing the scheduled maintenance identified in this owner's manual.

Careful periodic maintenance will help keep your vehicle in the safest, most reliable condition. Inspection, adjustment and lubrication of important components are explained in the periodic maintenance chart.

Inspect, clean, lubricate, adjust and replace parts as necessary. When inspection reveals the need for replacement parts, genuine POLARIS parts are available from your POLARIS dealer, or other qualified person. Equivalent parts may be used for emissions-related service.

Service and adjustments are important for proper vehicle operation. If you're not familiar with safe service and adjustment procedures, a qualified dealer can perform these operations.

Vehicles subjected to heavy or severe use patterns must be inspected and serviced more frequently.

SEVERE USE DEFINITION

- Frequent immersion in mud, water or sand
- Frequent or prolonged operation in dusty environments
- Short trip cold weather operation
- Racing or race-style high RPM use
- Prolonged low speed, heavy load operation
- Extended idle

Pay special attention to the oil level. A rise in oil level during cold weather can indicate contaminants collecting in the oil sump or crankcase. Change oil immediately if the oil level begins to rise. Monitor the oil level, and if it continues to rise, discontinue use and determine the cause. Your authorized dealer can assist.

MAINTENANCE

MAINTENANCE CHART KEY

SYMBOL	DESCRIPTION
XU	Perform these procedures more often for vehicles subjected to severe use.
D	Have an authorized POLARIS dealer or other qualified person perform these services.

WARNING

Improperly performing the procedures marked with a **D** could result in component failure and lead to serious injury or death. Have an authorized POLARIS dealer or other qualified person perform these services.

Perform all services at whichever maintenance interval is reached first. Record maintenance and service in the Maintenance Log.

ITEM		MAINTENANCE INTERVAL (WHICHEVER COMES FIRST)			REMARKS
		HOURS	CLNDR	MILES (KM)	
	PVT intake screen	-	Daily	-	Inspect; clean often
	Coolant	-	Daily	-	Check level
XU	Power steering unit (if equipped)	-	Daily	-	Inspect daily; clean often
	Head lamp / tail lamp	-	Daily	-	Verify proper operation
XU	Air filter	-	Weekly	-	Inspect; replace as needed
XU D	Brake pad wear	10 H	Monthly	100 (160)	Inspect periodically
	Battery	25 H	Monthly	200 (320)	Check terminals; clean; test
	Fuel System	25 H	Monthly	200 (320)	Inspect; cycle key to pressurize fuel pump; check lines and fittings for leaks and abrasion
XU	Demand drive fluid (front gearcase) (if equipped)	25 H	Monthly	-	Perform a break-in oil level check
XU	Transmission oil	25 H	Monthly	-	Perform a break-in oil level check
XU	Engine oil change (break-in)	25 H	-	500 (800)	Perform a break-in oil change
XU	General lubrication	50 H	3 M	500 (800)	Lubricate all fittings, pivots, cables, etc.

MAINTENANCE

ITEM		MAINTENANCE INTERVAL (WHICHEVER COMES FIRST)			REMARKS
		HOURS	CLNDR	MILES (KM)	
	Shift Linkage	50 H	6 M	500 (800)	Inspect, lubricate, adjust
D	Steering	50 H	6 M	500 (800)	Lubricate
XU	Front and Rear Stabilizer Bars	50 H	6 M	500 (800)	Lubricate
D	Throttle Pedal	50 H	6 M	500 (800)	Inspect for free movement; replace pedal as needed
	Throttle body air intake ducts/flange	50 H	6 M	500 (800)	Inspect ducts for proper sealing/air leaks
	Drive belt	50 H	6 M	500 (800)	Inspect; adjust; replace as needed
	Cooling system (if applicable)	50 H	6 M	500 (800)	Inspect coolant strength seasonally; pressure test system yearly
XU	Radiator (if applicable)	50 H	6 M	500 (800)	Inspect; clean external surfaces
XU	Shock absorbers	50 H	-	500 (800)	Inspect for leaks, loose joints, wear
XU D	Shock absorbers	250 H	-	2500 (4000)	Replace or rebuild (if applicable)
XU	Oil lines and fasteners	50 H	12 M	1000 (1600)	Inspect for leaks and loose fittings
XU	Engine oil and filter change	100 H	6 M	1000 (1600)	Change the oil and filter
XU	Front gearcase oil	100 H	12 M	1000 (1600)	Change fluid
XU	Transmission oil	100 H	12 M	1000 (1600)	Change fluid
D	Fuel System	100 H	12 M	1000 (1600)	Cycle key to pressurize fuel pump; check for leaks at fill cap, fuel lines/rail and fuel pump; replace lines every 2 years
XU	Cooling Hoses (if applicable)	100 H	12 M	1000 (1600)	Inspect for leaks
XU	Engine mounts	100 H	12 M	1000 (1600)	Inspect
	Exhaust muffler /pipe	100 H	12 M	1000 (1600)	Inspect

MAINTENANCE

ITEM		MAINTENANCE INTERVAL (WHICHEVER COMES FIRST)			REMARKS
		HOURS	CLNDR	MILES (KM)	
	Drive shafts	100 H	12 M	1000 (1600)	Remove and grease
D	Spark plug	100 H	12 M	1000 (1600)	Inspect; replace as needed
XU	Wiring	100 H	12 M	1000 (1600)	Inspect for wear, routing, security; apply dielectric grease to connectors subjected to water, mud, etc.
D XU	Clutches (drive and driven)	100 H	12 M	1000 (1600)	Inspect; clean; replace worn parts
D	Front wheel bearings	100 H	12 M	1000 (1600)	Inspect; replace as needed
D	Brake fluid	200 H	24 M	2000 (3200)	Change every two years
	Ratcheting cam chain tensioner	200 H	-	2000 (3200)	Check; adjust as needed
	Suspension bushings	250 H	24 M	2000 (3200)	Inspect; replace if necessary
XU	Spark arrester	300 H	36 M	3000 (4800)	Clean out
D	Valve clearance	-	-	5000 (8000)	Inspect; adjust as needed
XU	Coolant	-	60 M	-	Change coolant
D	Toe adjustment	-			Inspect periodically; adjust when parts are replaced
D XU	Auxiliary brake (if equipped)	-			Inspect daily; adjust as needed
	Headlight aim	-			Adjust as needed

LUBRICATION RECOMMENDATIONS

Check and lubricate all components at the intervals outlined in the Periodic Maintenance Chart section, or more often under severe use, such as wet or dusty conditions. Items not listed in the chart should be lubricated at the general lubrication interval.

MAINTENANCE

ITEM	LUBE	METHOD
Engine Oil	PS-4 5W-50 4-Cycle Oil	Add to proper level on dipstick. See page 73.
Brake Fluid	DOT 4 Brake Fluid	Maintain level between fill lines. See page 89.
Main Gearcase Oil (Transmission)	AGL Gearcase Lubricant & Transmission Fluid	See page 77.
Front Gearcase Oil	Demand Drive Fluid	See page 77.
Front Prop Shaft Yoke	U-Joint Grease	Locate fittings and grease (3 pumps maximum).
Front and Rear Stabilizer Bar Bushings	All Season Grease or grease conforming to NLGI No. 2	Grease one fitting on each side of the vehicle.

MAINTENANCE

ENGINE OIL

Always check and change the oil at the intervals outlined in the Periodic Maintenance Chart. Always use the recommended engine oil. Always change the oil filter whenever changing oil.

Pay special attention to the oil level. A rise in oil level during cold weather can indicate contaminants collecting in the oil sump or crankcase. Change oil immediately if the oil level begins to rise. Monitor the oil level, and if it continues to rise, discontinue use and determine the cause. Your dealer can assist.

WARNING

Vehicle operation with insufficient, deteriorated, or contaminated engine oil will cause accelerated wear and may result in engine seizure, accident and injury. Always perform the maintenance procedures as outlined in the Periodic Maintenance Chart.

OIL RECOMMENDATIONS

POLARIS recommends the use of POLARIS PS-4 5W-50 4-Cycle Oil or a similar oil. Refer to the Specifications section for capacities.

Oil may need to be changed more frequently if POLARIS PS-4 engine oil is not used. Follow the manufacturer's recommendations for ambient temperature operation. See the Polaris Products section for part numbers.

NOTICE

Mixing brands or using a non-recommended oil may cause serious engine damage. Always use the recommended oil. Never substitute or mix oil brands.

OIL CHECK

Always check the oil when the engine is cold. If the engine is hot when the oil is checked, the level will appear to be overfull.

⚠ CAUTION

Always remove all cargo from the cargo box before lifting the box to access engine components.

Access the oil fill cap, dipstick and filter under the cargo box.

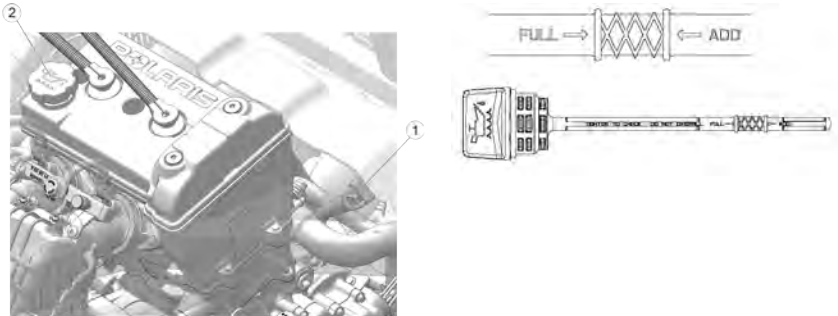

1. Remove all cargo from the cargo box. See page 62.
2. Position the vehicle on a level surface.
3. Place the transmission in PARK.
4. Stop the engine.
5. Stand clear and pull up on the cargo box release lever. Lift the front of the cargo box.
6. Remove the dipstick. Wipe it dry with a clean cloth.
7. Reinstall the dipstick completely. Remove the dipstick ① and check the oil level.
8. Remove the oil fill cap ② to add the recommended oil as needed. Maintain the oil level between the minimum and maximum marks on the dipstick. Do not overfill.
9. Reinstall the fill cap . Reinstall the dipstick.
10. Lower the cargo box and push down securely to latch.

MAINTENANCE

OIL AND FILTER CHANGE

Always change the oil and filters at the intervals outlined in the Periodic Maintenance Chart section. Always change the oil filter whenever changing oil.

The crankcase drain plug is located on the bottom of the crankcase. Access the drain plug through the access hole in the skid plate under the crankcase (see next page).

 CAUTION

Always remove all cargo from the cargo box before lifting the box to access engine components.

Access the oil fill cap, dipstick and filter under the cargo box.

1. Remove all cargo from the cargo box. See page 62.
2. Position the vehicle on a level surface.
3. Place the transmission in PARK.
4. Stand clear and pull up on the cargo box release lever. Lift the front of the cargo box.
5. For maximum clearance in the engine compartment, detach the cargo box shock from the base of the box.
6. Carefully detach the fuel line and spark plug wires from their retaining clips on the outlet hose, then loosen the outlet hose clamp and remove the hose from the clutch cover.

 CAUTION

Do not allow debris or other objects to enter the clutch cover.

7. Locate the crankcase drain plug access hole in the skid plate.
8. Clean the area around the crankcase drain plug.

 CAUTION

Hot oil can cause burns to skin. Do not allow hot oil to contact skin.

9. Place a drain pan under the engine crankcase and remove the drain plug. Allow the oil to drain completely.
10. Using an oil filter wrench, turn the filter counter-clockwise to remove it.
11. Using a clean dry cloth, clean the filter sealing surface on the crankcase.

12. Lubricate the o-ring on the new filter with a film of fresh engine oil. Check to make sure the o-ring is in good condition.
13. Install the new filter and turn by hand until the filter gasket contacts the sealing surface, then turn an additional 3/4 turn.
14. Reinstall the drain plug. Torque the drain plug to 12 ft-lbs (16 Nm).
15. Remove the oil fill cap and add 2.5 quarts (2.4 l) of recommended oil. Reinstall the fill cap.
16. Start the engine and check for leaks.
17. Stop the engine and wait 15 seconds before removing the dipstick.
18. Remove the dipstick. Wipe it dry with a clean cloth.
19. Reinstall the dipstick completely. Remove the dipstick and check the oil level.
20. Remove the oil fill cap and add oil as needed to bring the level to the upper mark on the dipstick. Do not overfill.
21. Reinstall the fill cap. Reinstall the dipstick.
22. Reinstall the outlet hose to the clutch box, routing the hose under the fuel line and spark plug wires. Make sure the clutch cover rib aligns in the notch at the end of the outlet hose. Tighten the clamp.
23. Reinstall the fuel line and spark plug wires to the retaining clips on the outlet hose.
24. Lower the cargo box and push down securely to latch.
25. Dispose of used filter and oil properly.

GEARCASES

TRANSMISSION (MAIN GEARCASE)

Always check and change the transmission oil at the intervals outlined in the Periodic Maintenance Chart section. Refer to the Gearcase Specifications Chart for recommended lubricants, capacities and torque specifications. See page 109 for the part numbers of POLARIS products.

OIL CHECK

The fluid check/fill plug is located on the rear of the gearcase. Maintain the oil level even with the bottom of the plug hole threads.

1. Position the vehicle on a level surface.
2. Remove the fill plug ①.
3. Check the fluid level.
4. Add the recommended fluid to the bottom of the fill plug hole. Do not overfill.
5. Reinstall the fill plug. Torque to specification.

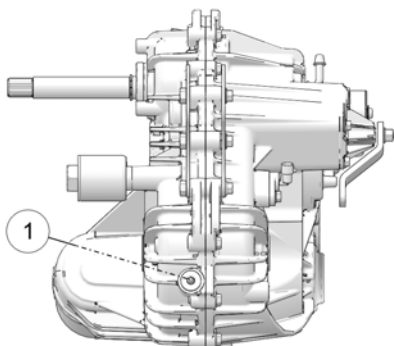

OIL CHANGE

The drain plug is located near the bottom of the gearcase.

1. Remove the fill plug ①.
2. Place a drain pan under the drain plug ②.
3. Remove the drain plug. Allow the fluid to drain completely.
4. Clean and reinstall the drain plug. Torque to specification.
5. Add the recommended fluid to the bottom of the fill plug hole. Do not overfill.
6. Reinstall the fill plug. Torque to specification.
7. Check for leaks. Discard used fluid properly.

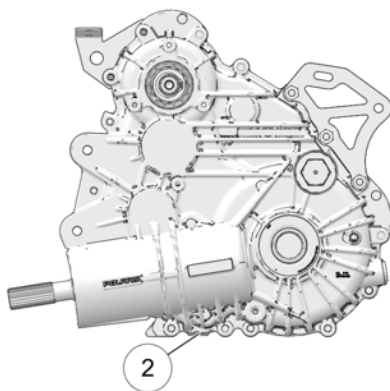

FRONT GEARCASE

Always check and change the front gearcase oil at the intervals outlined in the Periodic Maintenance Chart. Maintain the oil level even with the bottom thread of the fill plug hole. Refer to the Gearcase Specifications Chart for recommended lubricants, capacities and torque specifications. See *Lubricants/Service Products* for the part numbers of POLARIS products.

OIL CHECK

The front gearcase fill plug is located on the right side of the front gearcase.

1. Position the vehicle on a level surface.
2. Place the transmission in PARK.
3. Remove the fill plug ①. Check the oil level.
4. Add the recommended oil as needed.
5. Reinstall the fill plug. Torque to specification.

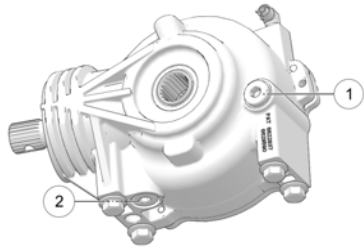

OIL CHANGE

1. Support the vehicle securely with a jackstand.
2. Remove the fill plug.
3. Place a drain pan under the drain plug.
4. Remove the drain plug. Allow the oil to drain completely.
5. Clean and reinstall the drain plug. Torque to specification.
6. Add the recommended oil.
7. Reinstall the fill plug. Torque to specification.
8. Check for leaks. Discard of used oil properly.

GEARCASE SPECIFICATION CHART

GEARCASE	LUBRICANT	CAPACITY	FILL PLUG TORQUE	DRAIN PLUG TORQUE
Main Gearcase (Transmission)	AGL Gearcase Lubricant & Transmission Fluid	44 oz. (1200 ml)	10-14 ft. lbs. (14-19 Nm)	10-14 ft. lbs. (14-19 Nm)
Front Gearcase	Demand Drive Fluid	7.5 oz. (250-275 ml)	8-10 ft. lbs. (11-14 Nm)	8-10 ft. lbs. (11-14 Nm)

SPARK PLUGS

SPARK PLUG RECOMMENDATIONS

Refer to the Specifications section for the recommended spark plug type for your vehicle. Always torque spark plugs to specification.

NOTICE

Using non-recommended spark plugs can result in serious engine damage. Always use POLARIS-recommended spark plugs or their equivalent.

SPARK PLUG GAP / TORQUE

ELECTRODE GAP	PLUG TORQUE
0.7-0.8 mm	7 ft. lbs. (9.5 Nm)

SPARK PLUG INSPECTION

Spark plug condition is indicative of engine operation. The spark plug firing end condition should be read after the engine is warmed up and the vehicle is driven at higher speeds. Immediately check the spark plug for correct color.

CAUTION

Always remove all cargo from the cargo box before lifting the box to access engine components.

1. Lift the cargo box. Remove the spark plug cap.

CAUTION

A hot exhaust system and engine can cause burns. Wear protective gloves when removing a spark plug for inspection.

2. Using the spark plug wrench provided in the tool kit, remove the plug by rotating it counter-clockwise.
3. Reverse the procedure for spark plug installation. Apply anti-seize compound to the spark plug threads.
4. Torque to specification.

MAINTENANCE

NORMAL PLUG

The normal insulator tip is gray, tan or light brown. There will be few combustion deposits. The electrodes are not burned or eroded. This indicates the proper type and heat range for the engine and the service.

The tip should not be white. A white insulator tip indicates overheating, caused by use of an improper spark plug or incorrect throttle body adjustments.

WET FOULED PLUG

The wet fouled insulator tip is black. A damp oil film covers the firing end. There may be a carbon layer over the entire nose. Generally, the electrodes are not worn. General causes of fouling are: incorrect spark plug type or heat range, excessive engine oil consumption or incorrect throttle body adjustments.

COOLING SYSTEM

The engine coolant level is controlled or maintained by the recovery system. The recovery system components are the overflow bottle, radiator filler neck, radiator pressure cap and connecting hose.

As coolant operating temperature increases, the expanding (heated) excess coolant is forced out of the radiator, past the pressure cap, and into the overflow bottle. As engine coolant temperature decreases, the contracting (cooled) coolant is drawn back up from the tank, past the pressure cap, and into the radiator.

Some coolant level drop on new vehicles is normal as the system is purging itself of trapped air. Observe coolant levels and maintain as recommended by adding coolant to the overflow bottle.

ADDING OR CHANGING COOLANT

POLARIS recommends the use of POLARIS Antifreeze 50/50 Premix. This antifreeze is already premixed and ready to use. Do not dilute with water.

To ensure that the coolant maintains its ability to protect the engine, we recommend that the system be completely drained every five (5) years and fresh Antifreeze 50/50 Premix added.

Any time the cooling system has been drained for maintenance or repair, replace the coolant with fresh Antifreeze 50/50 Premix. If the recovery bottle has run dry, the level in the radiator should be inspected. Add coolant as needed.

RADIATOR AND COOLING FAN

Always check and clean the screen and radiator fins at the intervals outlined in the Periodic Maintenance Chart. Do not obstruct or deflect air flow through the radiator by installing unauthorized accessories in front of the radiator or behind the cooling fan. Interference with the radiator air flow can lead to overheating and consequent engine damage.

NOTICE

Washing the vehicle with a high-pressure hose could damage the radiator fins and impair the radiator's effectiveness. Using a high-pressure system is not recommended.

OVERFLOW BOTTLE COOLANT LEVEL

Always check and change the coolant at the intervals outlined in the Periodic Maintenance Chart. Maintain the coolant level between the minimum and maximum marks on the bottle (when the fluid is cool).

1. Position the vehicle on a level surface.
2. Place the transmission in PARK.

MAINTENANCE

3. Remove the hood. See page 42.
4. View the coolant level in the overflow bottle.
5. If the coolant level is below the safe operating range, make sure the pressure cap is securely installed before adding coolant to the overflow bottle.

NOTE

Always add coolant through the bottle filler opening, not through the radiator pressure cap opening.

6. Reinstall the coolant bottle cap.

TIP

If coolant must be added often, or if the overflow bottle runs completely dry, there may be a leak in the system. Your POLARIS dealer, or other qualified person, can inspect the cooling system.

RADIATOR COOLANT LEVEL

Check the radiator coolant level **ONLY** if the overflow bottle is dry. If the overflow bottle contains fluid, the radiator level should **NOT** be inspected.

TIP

If the overflow bottle runs completely dry, there may be a leak in the system. Your POLARIS dealer, or other authorized, can inspect the cooling system.

1. Remove the hood. See page 42.

CAUTION

Escaping steam can cause burns. Never remove the pressure cap while the engine is warm or hot. Always allow the engine to cool before removing the pressure cap.

2. If the overflow bottle is dry, slowly remove the radiator pressure cap.
3. View the coolant level through the opening.
4. Use a funnel and slowly add coolant as needed.
5. Reinstall the pressure cap securely. Use of a non-standard pressure cap will not allow the recovery system to function properly. Your POLARIS dealer, or other qualified person, can provide the correct replacement part.
6. With the pressure cap securely installed, add coolant to the overflow bottle to the recommended level. Reinstall the coolant bottle cap.

POLARIS VARIABLE TRANSMISSION (PVT) SYSTEM

WARNING

Failure to comply with the instructions in this warning can result in severe injury or death. Do not modify any component of the PVT system. Doing so may reduce its strength so that a failure may occur at a high speed. The PVT system has been precision balanced. Any modification will cause the system to be out of balance, creating vibration and additional loads on components.

The PVT system rotates at high speeds, creating large amounts of force on clutch components. As the owner, you have the following responsibilities for your own safety and the safety of others:

- Always follow all recommended maintenance procedures. Always look for and remove debris inside and around the clutch and vent system when replacing the belt.
- See your dealer or other qualified service person as outlined in the owner's manual.
- This PVT system is intended for use on POLARIS products only. Do not install it in any other product.
- Always make sure the PVT housing is securely in place during operation.

BELT REPLACEMENT / DEBRIS REMOVAL

If a belt fails, always clean any debris from the duct and from the clutch and engine compartments when replacing the belt.

WARNING

Failure to remove ALL debris when replacing the belt could result in vehicle damage, loss of control and severe injury or death.

1. Allow hot components to cool before performing this procedure.
2. Remove the engine access cover and thoroughly clean all debris from the aluminum debris bracket and from the engine compartment.
3. Remove the clutch cover screws and open the clutch cover. (It does not have to be removed from the vehicle.) Remove all debris wrapped in and around the PVT system.

TIP

Use the shock/clutch tool from the tool kit to slightly open the sheaves to aid in debris removal and belt installation.

MAINTENANCE

4. Remove all debris from the entire clutch air duct passage.
5. Check for signs of damage to seals on the transmission and engine. If any seals appear to be damaged, your vehicle requires prompt service. Your POLARIS dealer can assist.

TIP

Belt slip is responsible for creating excessive heat that destroys belts, wears clutch components and causes outer clutch covers to fail. Switch to low range while operating at slower speeds to extend the life of the PVT components (belt, cover, etc.).

PVT DRYING

There may be some instances when water is accidentally ingested into the PVT system. Use the following instructions to dry it out before operating.

1. Remove the clutch cover drain plug.
2. Allow the water to drain. Reinstall the drain plug.
3. Place the transmission in PARK. Apply the brakes.
4. Start the engine.
5. Apply varying throttle for 10-15 seconds to expel the moisture and air-dry the belt and clutches. Do not hold the throttle wide open for more than 10 seconds.
6. Allow the engine RPM to settle to idle speed. Apply the brakes. Shift the transmission to the lowest available range.
7. Test for belt slippage. If the belt slips, repeat the process.
8. Your vehicle requires service as soon as possible. Your POLARIS dealer, or other qualified person, can assist.

VEHICLE IMMERSION

WARNING

If your vehicle becomes immersed, major engine damage can result if the machine is not thoroughly inspected. Take the vehicle in for service before starting the engine. Your POLARIS dealer, or other qualified person, can provide this service.

If it's impossible to take your POLARIS vehicle to a dealer before starting it, follow the steps outlined below:

1. Move the vehicle to dry land, or at the very least, to water below the floorboard.
2. Dry any water present in the air box. Filter replacement is required if water is present.
3. Dry any water present in the intake manifold.
4. Remove the spark plugs. Turn the engine over several times using the electric start.
5. Dry the spark plugs and reinstall, or replace with new plugs.
6. Attempt to start the engine. If necessary, repeat the drying procedure.
7. Take the vehicle in for service as soon as possible, whether you succeed in starting it or not. Your POLARIS dealer, or other qualified person, can provide the required service.
8. If water has been ingested into the PVT follow the PVT Drying procedure.

STEERING WHEEL INSPECTION

Check the steering wheel for specified freeplay and smooth operation at the intervals outlined in the Periodic Maintenance Chart section.

1. Position the vehicle on level ground.
2. Lightly turn the steering wheel left and right.
3. There should be 0.8-1.0 in (20-25 mm) of freeplay.
4. If there is excessive freeplay or strange noises, or the steering feels rough or “catchy,” have the steering system inspected by an authorized dealer.

POWER STEERING UNIT (IF EQUIPPED)

If your model is equipped with power steering, frequently clean the areas around and on the power steering unit to allow proper cooling. Clean these areas ③ thoroughly.

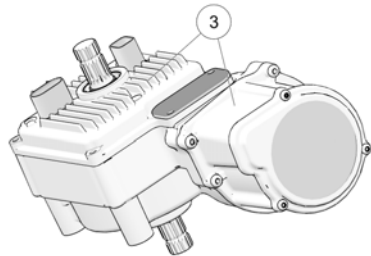

MAINTENANCE

FILTER SYSTEMS

AIR FILTER

Always change the air filter at the intervals outlined in the Periodic Maintenance Chart. Service the air filter more frequently if the vehicle is operated in wet conditions or at high throttle for extended periods.

1. Lift the cargo box to access the air box.
2. Release the air box cover latches and remove the cover.
3. Remove the air filter.
4. Inspect the air box for oil or water deposits. Wipe away any deposits with a clean cloth.
5. Install a new filter if needed. Do not attempt to clean the air filter.

PVT INTAKE SCREEN

The PVT intake screen is located on the driver's side of the vehicle.

Inspect the screen before each use of the vehicle. Remove all dirt and debris from the screen and clean it frequently with warm soapy water.

SPARK ARRESTOR

WARNING

- Never operate the vehicle without the spark arrestor.
- Remove any combustible materials from the area.

Failure to heed the following warnings while servicing the spark arrestor could result in serious injury or death.

- Never run the engine in an enclosed area. Exhaust contains poisonous carbon monoxide gas that can cause loss of consciousness or death in a very short time.
- Do NOT perform service on the spark arrestor while the system is HOT. Exhaust system temperatures can reach extreme temperatures. Allow components to cool sufficiently before proceeding.
- Do not stand behind or in front of the vehicle while purging the exhaust system.
- Never go under the vehicle while it is inclined.
- Wear eye protection and gloves while servicing.

Periodically clean the spark arrestor to remove accumulated carbon.

1. Place the transmission in PARK.
2. Remove the arrestor retaining bolt and nut.
3. Remove the arrestor from the end of the muffler.
4. Use a non-synthetic brush to clean the arrestor screen. A synthetic brush may melt if components are warm. If necessary, blow debris from the screen with compressed air.
5. Inspect the screen for wear and damage. Replace a worn or damaged screen.
6. Reinstall the arrestor.
7. Torque the bolt to 9-11 ft. lbs. (12-15 Nm).

BRAKES

The front and rear brakes are hydraulic disc type brakes activated by the brake pedal.

WARNING

Do not perform maintenance immediately after the vehicle has been operated, as the brake system may become very hot. Serious burns could result from contact with hot brake components. Allow components to cool before proceeding. Always wear eye protection and gloves.

BRAKE FLUID

Inspect the brake system routinely. Inspect the level of the brake fluid before each operation.

WARNING

After opening a bottle of brake fluid, always discard any unused portion. Never store or use a partial bottle. Brake fluid is hygroscopic, meaning it rapidly absorbs moisture from the air. The moisture causes the boiling temperature of the brake fluid to drop, which can lead to early brake fade and the possibility of accident or severe injury.

Change the brake fluid every two years and any time the fluid becomes contaminated, the fluid level is below the minimum, or if the type and brand of the fluid in the reservoir are unknown.

1. Position the vehicle on a level surface.
2. Place the transmission in PARK.
3. View the brake fluid level at the reservoir in the driver's side wheel well.
4. The level should be between the upper (MAX) and lower (MIN) level lines.
5. If the fluid level is lower than the upper level line, add brake fluid to the upper (MAX) line.
6. Apply the brake forcefully for a few seconds and check for fluid leakage around the fittings.

BRAKE INSPECTION

WARNING

Do not apply WD-40® or any petroleum product to brake discs. These types of products are flammable and may also reduce the friction between the brake pad and caliper.

1. Check the brake system for fluid leaks.
2. Check the brake pedal for excessive travel or a spongy feel.
3. Check the friction pads for wear, damage and looseness.
4. Check brake discs for signs of cracks, excessive corrosion, warping or other damage. Clean any grease using an approved brake cleaner or alcohol.
5. Inspect the brake disc spline and pad wear surface for excessive wear. Change pads when worn to 0.030" (0.762 mm).

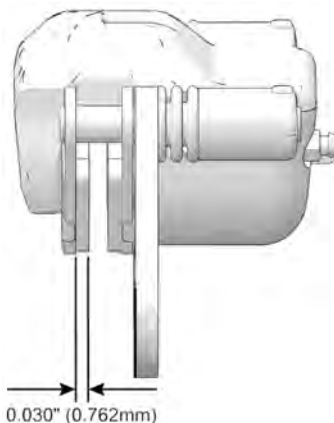

SUSPENSION SETTINGS

FRONT/REAR SPRING PRELOAD

The front and rear suspensions are preload adjustable. The suspensions are set on the lowest setting at the factory. The factory setting is appropriate for nearly all riding conditions.

If desired, the suspension may be adjusted to maintain vehicle clearance height when carrying loads. *Always heed the following rules if you make adjustments to this suspension.*

- Always return the suspension to the lowest setting after the load is removed from the vehicle. The increased suspension height will negatively impact vehicle stability when operating without a load.
- Always apply the same adjustment setting to *all four wheels*.
- Do not increase the spring preload by more than one inch (25.4 mm) over the factory setting.

FACTORY PRELOAD SETTINGS	
Front	1.5 inches (38.1 mm)
Rear	0.4 inches (10.2 mm)

Your POLARIS dealer, or other qualified person, can provide the tool required to make suspension adjustments.

1. Elevate the vehicle to allow the suspension to fully extend.
2. Loosen the jam nut and back it away from the adjusting ring.
3. Turn the adjusting ring to the left (1) to increase preload for a stiffer ride. Turn the adjusting ring to the right (2) to decrease preload for a softer ride.

 **WARNING**

Uneven adjustment may cause poor handling of the vehicle, which could result in an accident. Always adjust both the left and right spring preloads equally. Your POLARIS dealer, or other qualified person, can assist.

4. Tighten the jam nut firmly against the adjuster ring.

MAINTENANCE

FRONT/REAR SHOCK COMPRESSION

The compression damping adjustment is located on the shock 'Piggyback' reservoir of each shock. Damping adjustments can be made without using any tools.

Turn the adjuster knob clockwise to increase compression damping. Turn the adjuster knob counter-clockwise to decrease compression damping.

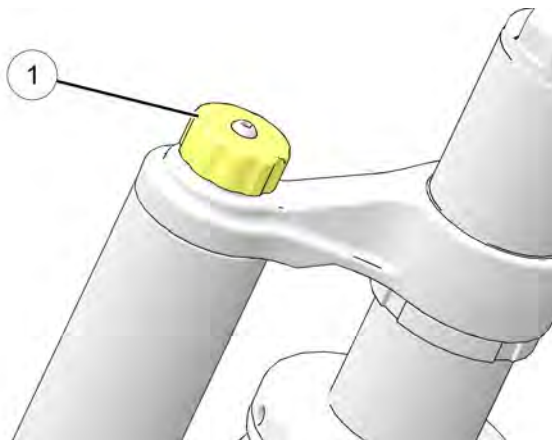

FACTORY COMPRESSION SETTINGS	
Front Shock	8 clicks from full hard
Rear Shock	8 clicks from full hard

TIRES

WARNING

Operating your vehicle with worn tires will increase the possibility of skidding, loss of control and an accident, which could result in serious injury or death. Always replace tires when the tread depth measures 1/8 in (3 mm) or less. Improper tire inflation or the use of non-standard size or type of tires may adversely affect vehicle handling, which could result in vehicle damage or personal injury. Always maintain proper tire pressure. Always use POLARIS approved size and type of tires for this vehicle when replacing tires.

TIRE TREAD DEPTH

Always replace tires when tread depth is worn to 3 mm (1/8") or less.

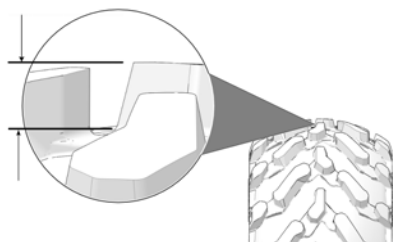

AXLE AND WHEEL NUT TORQUE SPECIFICATIONS

Inspect the following items occasionally for tightness, and if they've been loosened for maintenance service. Do not lubricate the stud or the lug nut.

NUT TYPE	LOCATION	NUT TORQUE
Lug Nut (Aluminum Wheels) 	Front and Rear	120 ft-lbs (163 Nm)

WHEEL REMOVAL

1. Position the vehicle on a level surface.
2. Place the transmission in PARK. Stop the engine.
3. Loosen the wheel nuts slightly.
4. Elevate the side of the vehicle by placing a suitable stand under the frame.
5. Remove the wheel nuts. Remove the wheel.

WHEEL INSTALLATION

WARNING

Improperly installed wheels can adversely affect tire wear and vehicle handling, which can result in serious injury or death. Always ensure that all nuts are torqued to specification. Do not service axle nuts that have a cotter pin installed. Your dealer can assist.

NOTICE

Front and rear wheels have different wheel offsets. Make sure the correct wheel is used in the correct location.

1. Place the transmission in PARK.
2. Place the wheel on the hub with the valve stem toward the outside.
3. Attach the wheel nuts and finger-tighten.
4. Carefully lower the vehicle to the ground.
5. Torque the wheel nuts to specification.

FUSES

If the engine stops or will not start, or if you experience other electrical failures, a fuse may need replacement. Locate and correct any short circuits that may have caused the blown fuse, then replace the fuse. Raise the driver's seat and remove the access panel to access the fuse center. Spare fuses can be found in the tool kit.

If you suspect that a fuse or relay may not be working properly, please see your dealer, or other qualified person.

FUSE SIZE	FEATURE SUPPORTED
10A	EFI
15A	Lights
10A	Term
10A	Accessory
25A	Info
25A	EPS
10A	Unswitched Power
10A	Drive
10A	Key
25A	Fan Circuit Breaker

LIGHTS

Poor lighting can result in reduced visibility when driving. Headlight and taillight lenses become dirty during normal operation. Clean lights frequently and replace burned out lamps promptly. Do not operate this vehicle at night or in low light conditions until the headlight is replaced. Always make sure lights are adjusted properly for best visibility.

HEADLIGHT REPLACEMENT

If a headlight becomes damaged or inoperable, the entire headlight assembly must be replaced. Do not operate this vehicle at night or in low light conditions until the headlight is replaced. Always make sure lights are adjusted properly for best visibility.

HEADLIGHT BEAM ADJUSTMENT

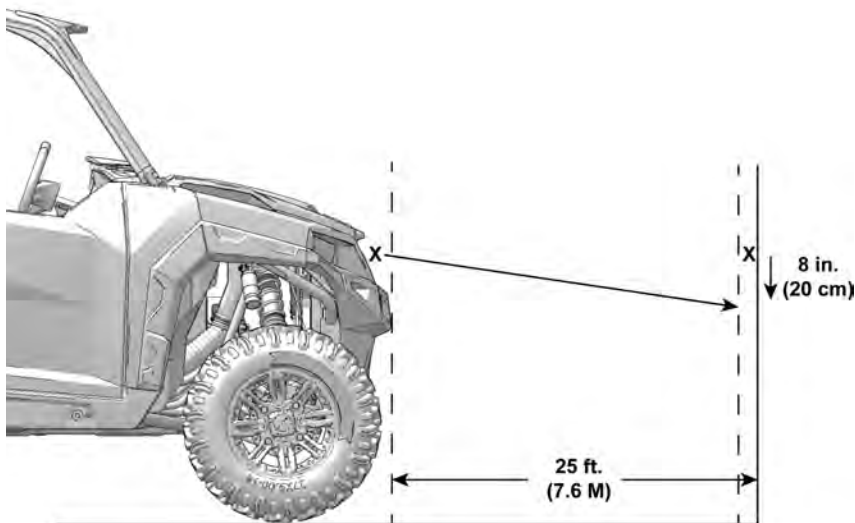

1. Place the vehicle on a level surface with the headlight approximately 25 ft. (7.6 m) from a wall.
2. Place the transmission in PARK.
3. Measure the distance from the floor to the center of the headlight and make a mark on the wall at the same height.
4. Apply the brakes. Start the engine. Turn on the headlights.
5. Observe the headlight aim. The most intense part of the headlight beam should be aimed 8" (20 cm) below the mark placed on the wall. Include the weight of a rider on the seat while performing this step.
6. If a headlight needs adjustment, locate the adjustment screw at the back of the headlight.
7. Loosen the screw. Adjust the headlight, then tighten the screw.
8. Repeat steps 5-7 until the lamp is properly adjusted.

BATTERY

WARNING

Improperly connecting or disconnecting battery cables can result in an explosion and cause serious injury or death. When removing the battery, always disconnect the negative (black) cable first. When reinstalling the battery, always connect the negative (black) cable last.

Your vehicle has a low-maintenance battery. Always keep battery terminals and connections free of corrosion. If cleaning is necessary, remove the corrosion with a stiff wire brush. Wash with a solution of one tablespoon baking soda and one cup water. Rinse well with tap water and dry off with clean shop towels. Coat the terminals with dielectric grease or petroleum jelly.

BATTERY REMOVAL

The battery is located under the driver's seat on 2 passenger vehicles. On 4 passenger vehicles, the battery is under the left rear passenger seat.

1. Park the vehicle on a flat, level surface.
2. Ensure the vehicle is in PARK.
3. Turn the key switch to OFF and remove the key.
4. To access the battery, remove the seat. See *Seat removal*.
5. Remove the battery access panel.
6. Loosen the black (negative) battery cable fastener. Remove the cable from the battery and move the cable away from the battery terminal.
7. Loosen the red (positive) battery cable fastener. Remove the cable from the battery and move the cable away from the battery terminal.
8. Remove the battery hold-down strap.
9. Lift the battery out of the vehicle.

BATTERY INSTALLATION

Using a new battery that has not been fully charged can damage the battery and result in a shorter life. It can also hinder vehicle performance. Follow the battery charging instructions in the AGM Battery Maintenance and Charging section before installing the battery.

1. Ensure that the battery is fully charged.
2. Place the battery in the battery holder.
3. Coat the terminals with dielectric grease or petroleum jelly.
4. Secure the battery hold-down strap.

MAINTENANCE

5. Connect and tighten the red (positive) cable first.
6. Connect and tighten the black (negative) cable last.
7. Verify that cables are properly routed.

BATTERY MAINTENANCE AND CHARGING

WARNING

An overheated battery may explode, causing severe injury or death. Always watch charging times carefully. Stop charging if the battery becomes very warm to the touch. Allow it to cool before resuming charging.

The sealed battery is already filled with electrolyte and has been sealed and *fully charged* at the factory. *Never* pry the sealing strip off or add any other fluid to this battery.

The single most important thing about maintaining a sealed battery is to keep it fully charged. Check the battery voltage with a voltmeter or multimeter. A fully charged battery will register 12.8 V or higher. If the voltage falls below 12.5V, charge it immediately, or the battery runs the risk of sulfation and reduced battery life.

If you do not drive the vehicle for more than TWO WEEKS, Polaris recommends using a BatteryMINDER® 2012 AGM - 2 AMP charger (PN 2830438), which can be ordered through your dealer.

Polaris provides a charging accessory with your vehicle that allows easy connection to the battery through the 12V auxiliary outlet, located on the dash. During charging, place the charger outside of the vehicle and protect it from moisture.

IMPORTANT

The 12V socket located in the rear of 4 seat vehicles is powered after key-on and **CANNOT** be used for charging.

If you plan to store the vehicle for ONE MONTH or longer, remove the battery from the vehicle, then store the battery in a cool and dry location. Continue to maintain the battery with the BatteryMINDER® 2012 AGM - 2 AMP charger.

When using an automatic charger other than a BatteryMINDER® 2012-AGM - 2 AMP charger, refer to the charger manufacturer's instructions for recharging.

If using a **constant current charger** (instead of BatteryMINDER® 2012 AGM - 2 AMP charger), use the guidelines below. Always verify battery condition before and 1-2 hours after the end of charging.

MAINTENANCE

STATE OF CHARGE	VOLTAGE (DC)	ACTION	CHARGE TIME*
100%	12.8-13.0 volts	None, check monthly	None required
75%-100%	12.6-12.8 volts	May need slight charge, if no charge given, check in 2 weeks	3-6 hours
50%-75%	12.3-12.6 volts	Needs charge	5-11 hours
25%-50%	12.0-12.3 volts	Needs charge	At least 13 hours
0%-25%	12.0 volts or less	Needs charge	At least 20 hours

* Using AGM specific charger at standard amps specified on top of battery

CLEANING AND STORAGE

WASHING THE VEHICLE

Keeping your POLARIS vehicle clean will not only improve its appearance but it can also extend the life of various components.

Water in the PVT system could cause the drive belt to become wet and slip in the clutches. Always avoid spraying water directly toward any intake pre-filters. If water does enter the PVT intake, follow the procedure on *PVT Drying*.

High water pressure may damage radiator fins and impair a radiator's effectiveness. High pressure may also damage other vehicle components.

Certain products, including insect repellents and chemicals, will damage plastic surfaces. Do not allow these types of products to contact the vehicle.

The best and safest way to clean your POLARIS vehicle is with a garden hose and a pail of mild soap and water.

1. Use a professional-type washing cloth, cleaning the upper body first and the lower parts last.
2. Rinse with clean water frequently.
3. Dry surfaces with a chamois to prevent water spots.

WASHING TIPS

- Avoid the use of harsh cleaners, which can damage the finish.
- Do not use medium to heavy duty compounds on the finish.
- Always use clean cloths and pads for cleaning and polishing. Old or reused cloths and pads may contain dirt particles that will scratch the finish.
- Do not use high-speed polishers/buffers on body panels, as damage or color fading may occur.
- Do not spray water directly into the intake ducts.

If a high pressure water system is used for cleaning, exercise extreme caution. The maximum pressure should not exceed 3000 PSI, 2.5 GPM with a 40° pressure washer nozzle. Make sure to keep the pressure washer nozzle 2 ft (.6 m) from the vehicle away from the surface being cleaned. The water may damage components and could remove paint and labels. Avoid directing the water stream at the following items:

- Wheel bearings
- Radiator
- Transmission seals
- Brakes
- Cab and body panels
- Labels and decals
- Electrical components and wiring
- Air intake components
- Throttle and shift cables and controls
- Seat Belts
- Seats

WARNING

Spilled oil left on engine components or in the engine area may pose a fire hazard. Use shop rags to clean any spilled oil. If needed, use a non-flammable solvent on the rag to aid in the cleaning process. Do not use any device such as a pressurized water or air as this may disperse the oil onto engine components and could pose a fire hazard.

WARNING

Clean seat belts with warm water. Avoid damaging seat belts:

- Do not use bleach, dye or household detergents.
- Never use lubricant on any seat belt component.
- Do not use a pressure washer to clean the seat belts.

If warning and safety labels are damaged, contact your POLARIS dealer for free replacement.

Grease all zerk fittings (if applicable) immediately after washing. Allow the engine to run for a while to evaporate any water that may have entered the engine or exhaust system.

POLISHING THE VEHICLE

POLARIS recommends the use of common household aerosol furniture polish for polishing the finish on your POLARIS vehicle. Follow the instructions on the container.

POLISHING TIPS

- Avoid the use of automotive products, some of which can scratch the finish of your vehicle.
- Always use clean cloths and pads for cleaning and polishing. Old or reused cloths and pads may contain dirt particles that will scratch the finish.

STORAGE TIPS

NOTICE

Starting the engine during the storage period will disturb the protective film created by fogging and damage could occur. Never start the engine during the storage period.

CLEAN THE EXTERIOR

Make any necessary repairs and clean the vehicle as recommended.

STABILIZE THE FUEL

1. Fill the fuel tank.
2. Add POLARIS Carbon Clean Fuel Treatment or POLARIS Fuel Stabilizer or equivalent fuel treatments or stabilizers. Follow the instructions on the container for the recommended amount. Carbon Clean removes water from fuel systems, stabilizes fuel and removes carbon deposits from pistons, rings, valves and exhaust systems.
3. Allow the engine to run for 15-20 minutes to allow the stabilizer to disperse through the entire fuel delivery system.

OIL AND FILTER

Change the oil and filter. See the Engine Oil section.

AIR FILTER / AIR BOX

Replace the air filter. See Maintenance Chapter. Clean the air box.

INSPECT AND LUBRICATE

Inspect all cables and lubricate all areas of the vehicle as recommended in the Periodic Maintenance Chart section.

BATTERY MAINTENANCE

See the Battery Storage section and Battery Charging section for storage and charging procedures.

MAINTENANCE

FOG THE ENGINE

1. Treat the fuel system with POLARIS Carbon Clean or other equivalent fuel treatment. Follow the instructions on the container. Start the engine. Allow it to idle for several minutes so the Carbon Clean reaches the injectors. Stop the engine.
2. Remove the spark plugs and add 1–1.5 oz. (29.5–44 cc.) of engine oil. To access the plug holes, use a section of clear 6 mm (1/4") hose and a small plastic squeeze bottle filled with the pre-measured amount of oil. *Do this carefully! If you miss the plug holes, oil will drain from the spark plug cavities into the hole at the front of the cylinder head, and appear to be an oil leak.*
3. Reinstall the spark plugs. Torque to specification.
4. Apply dielectric grease to the inside of each spark plug cap. *Do not reinstall the cap onto the plug at this step.*
5. Turn the engine over several times. Oil will be forced in and around the piston rings and ring lands, coating the cylinder with a protective film of fresh oil.
6. Reinstall the spark plug caps.
7. If POLARIS fuel system additive is not used, fuel tank, fuel lines, and injectors should be completely drained of gasoline.

STORAGE AREA / COVERS

Be sure the storage area is well ventilated. Cover the vehicle with a genuine POLARIS cover or similar that allows for adequate airflow. Do not use plastic or coated material, as these materials do not allow enough ventilation to prevent condensation and may promote corrosion and oxidation.

FLUID LEVELS

Inspect the fluid levels. Add or change fluids as recommended in the Periodic Maintenance Chart.

- Demand drive fluid (front gearcase)
- Rear gearcase fluid (if equipped)
- Transmission fluid
- Brake fluid (change every two years and any time the fluid looks dark or contaminated)
- Coolant (test strength/fill)

REMOVAL FROM STORAGE

 **WARNING**

Engine exhaust contains poisonous carbon monoxide and can cause loss of consciousness or death. Never run an engine in an enclosed area.

1. Check the battery electrolyte level and charge the battery if necessary. Install it in the vehicle. Make sure the battery vent hose is routed properly and that it's not pinched or restricted in any way.
2. Make sure spark plugs are tight.
3. Fill the fuel tank with fuel.
4. Check all the points listed in the Daily Pre-Ride Inspection. *Tightness of the bolts, nuts and other fasteners should be checked by an authorized dealer or other qualified service facility.*
5. Lubricate at the intervals outlined in the Periodic Maintenance Chart.

MAINTENANCE

TRANSPORTING THE GENERAL

Follow these procedures when transporting the vehicle.

1. Place the transmission in PARK. Stop the engine.
2. Slowly release the brake pedal and make sure the transmission is in PARK before exiting the vehicle.
3. Remove the key to prevent loss during transporting.
4. Secure the fuel cap, hood, doors (if equipped) and cargo box. Ensure that the seats are attached correctly and are not loose.

 **WARNING**

Cargo and other loose vehicle parts may fly off while transporting this vehicle. Secure or remove all cargo, and inspect the unit for loose parts prior to transport.

If transporting the vehicle in a non-enclosed trailer, then the vehicle must FACE FORWARD, or roof must be removed.

Failure to comply may allow airflow, vibration, or other factors to separate the roof from the vehicle and cause an accident, resulting in serious personal injury or death.

5. Always tie the frame of the POLARIS vehicle to the transporting unit securely with suitable straps or rope. Do not attach tie straps to the front A-arm bolt pockets.

SPECIFICATIONS

GENERAL XP 1000

Maximum Weight Capacity (including operator, passenger, cargo, non-factory installed accessories)	1000 lbs. (454 kg)
Dry Weight	Sport: 1668 lbs. (756 kg) Premium: 1679 lbs. (762 kg) Ultimate: 1718 lbs. (779 kg)
Test GVW - Rollover Protection System (ROPS)	3000 lbs. (1360 kg) per ISO 3471:2008
Fuel Capacity	9.5 gal. (36 L)
Engine Oil Capacity	2.5 qts. (2.4 L)
Coolant Capacity	5.44 qts. (5.1 L)
Towing Capacity	2000 lbs. (907 kg)
Hitch Tongue Capacity	150 lbs. (68 kg)
Max. Cargo Box Load*	600 lbs. (272 kg)
Overall Length	118 in. (299.7 cm)
Overall Width	66.4 in. (168.7 cm)
Overall Height	77.5 in. (196.9 cm)
Wheelbase	82.7 in. (210 cm)
Cargo Box Dimensions (Inside)	26 x 43 x 11 in. (66 x 109 x 28 cm)
Ground Clearance	13.5 in. (34.3 cm)
Min. Turning Radius	190 in. (483 cm)
Engine	4-Stroke DOHC Twin Cylinder
Displacement	999 cc
Bore x Stroke	93 mm x 73.5 mm
Alternator Output	560 W @ 3000 RPM
Compression Ratio	10.5:1
Starting System	Electric
Fuel System	Electronic fuel injection
Ignition System	Electronic

SPECIFICATIONS

Spark Plug / Gap	MR7F / 0.7-0.8 mm
Front Suspension	Independent Double A-arm w/14 in. (35.6 cm) of travel
Rear Suspension	Independent Double A-arm w/14 in. (35.6 cm) of travel
Lubrication System	Wet Sump
Driving System Type	Automatic POLARIS Variable Transmission
Shift Type	Single Lever Dual Range (H/L/N/R/P)
Transmission Gear Ratio - High	Front 4.03:1 / Rear 12.05:1
Transmission Gear Ratio - Low	Front 8.56:1 / Rear 25.59:1
Transmission Gear Ratio - Reverse	Front 7.67:1 / Rear 22.92:1
Front Drive Ratio	3.18:1
Tire Size - Front	30 x 10 x 15
Tire Size - Rear	30 x 10 x 15
Tire Pressure - Front	10 psi (69 kPa)
Tire Pressure - Rear	14 psi (97 kPa)
Brakes, Front/Rear	Foot Activated, 4-wheel hydraulic disc
Hood Headlight	LED
Taillights	LED
Brake Light	LED
Mounted Light Bar (if equipped)	If light fails, replace entire assembly
Instrument Cluster	Analog and LCD
Auxiliary DC Outlet	12V

Dry weight is also listed on the Certificate of Origin for your vehicle in the Shipping Weight field. The dry weight is estimated based on the manufactured weight of the vehicle minus any serviceable fluids and may also exclude the weight of factory installed accessories not essential to the vehicle's basic operation as outlined in ANSI®/ROHVA® 1–2016 standard.

CLUTCHING (GENERAL)

See your POLARIS dealer or qualified person for clutching specifications.

POLARIS PRODUCTS

LUBRICANTS / SERVICE PRODUCTS

PRODUCT	SIZE (QUANTITY)	QUANTITY	PART NUMBER
Fogging Oil	12 fl oz (355 mL) aerosol	12	2870791
	1 qt (0.95 L)	12	2871517
PS-4	1 qt (0.95 L)	12	2876244
	2 qt (1.90 L)	8	2877490
	1 gal (3.8 L)	4	2876245
PS-4 Extreme Duty	1 qt (0.95 L)	12	2878920
	2 qt (1.90 L)	8	2878922
	1 gal (3.8 L)	4	2878919
	1 qt (0.95 L)	12	2889395
	1 gal (3.8 L)	4	2889396
AGL	1 qt (0.95 L)	12	2878068
	1 gal (3.8 L)	4	2878069
Pump for Gallon Jug	—	1	2870465
Demand Drive	1 qt (0.95 L)	12	2877922
	2.5 gal (9.5 L)	2	2877923
Antifreeze / Coolant	1 qt (0.95 L)	12	2880514
	1 gal (3.8 L)	6	2880513
Grease Gun Kit, Premium All Season	—	1	2871312
All Season Grease	Four 3 fl oz (89 mL) packs	6	2871322
	14 fl oz (414 mL) cartridge	1	2871423
Premium Starter Grease	—	1	2871460
U-Joint Grease	3 fl oz (89 mL) tube	24	2871515
	14 fl oz (414 mL) cartridge	1	2871551
Dielectric Grease (Nyogel®)	—	1	2871329

POLARIS PRODUCTS

PRODUCT	SIZE (QUANTITY)	QUANTITY	PART NUMBER
Carbon Clean	12 fl oz (355 mL) bottle	12	2871326
Fuel Stabilizer	16 fl oz (473 mL)	12	2870652
	2.5 gal (9.5 L)	2	2872280
DOT 4 Brake Fluid	—	1	2872189
Loctite® 565 Thread Sealant	—	1	2871956
BatteryMINDER® 2012 AGM - 2 AMP Charger	—	1	2830438

TROUBLESHOOTING

DRIVE BELT WEAR/BURN

POSSIBLE CAUSE	SOLUTION
Driving onto a pickup or tall trailer in high range	Use low range during loading.
Starting out going up a steep incline	Use low range.
Driving at low RPM or ground speed – 3–7 mph (4.8–11.3 km/h)	Drive at a higher speed or use low range more frequently.
Insufficient warm-up at low ambient temperatures	Warm the engine at least 5 minutes. With the transmission in neutral, advance the throttle to about 1/8 throttle in short bursts, 5 to 7 times. The belt will become more flexible and prevent belt burning.
Slow/easy clutch engagement	Use the throttle quickly and effectively.
Towing/pushing at low RPM/low ground speed	Use low range only.
Utility use/plowing	Use low range only.
Stuck in mud or snow	Shift the transmission to low range and carefully use fast, aggressive throttle application to engage clutch. WARNING: Excessive throttle may cause loss of control and vehicle rollover.
Climbing over large objects from a stopped position	Shift the transmission to low range and carefully use fast, brief, aggressive throttle application to engage clutch. WARNING: Excessive throttle may cause loss of control and vehicle rollover.
Belt slippage from water or snow ingestion into the PVT system	Dry out the PVT. Prevent water from entering the PVT intake duct. See Intake Pre-Filters for more information. Inspect clutch seals for damage if repeated leaking occurs.
Clutch malfunction	An authorized dealer can assist.
Poor engine performance	Check for clogged air filter, clogged fuel filter, water in the fuel or foreign material in fuel tank or fuel lines. An authorized dealer can assist.
Slippage from failure to warm up belt	Always warm up the belt by operating below 30 mph (48 km/h) for 1 miles (1.6 km) (5 miles (8 km) or more when temperature is below freezing).
Wrong or missing belt	Install the recommended belt.
Improper break-in	Always break in a new belt and/or clutch.

TROUBLESHOOTING

ENGINE DOESN'T TURN OVER

POSSIBLE CAUSE	SOLUTION
Low battery voltage	Recharge the battery.
Loose battery connections	Check all connections and tighten.
Loose solenoid connections	Check all connections and tighten.
Loose electronic control box connections	Inspect, clean, reinstall connectors.

ENGINE TURNS OVER, FAILS TO START

POSSIBLE CAUSE	SOLUTION
Out of fuel	Refuel.
Water is present in fuel	Drain the fuel system and refuel.
Old or non-recommended fuel	Replace with fresh recommended fuel.
Fouled or defective spark plug	Inspect plug and replace if necessary.
No spark to spark plug	Inspect plug and replace if necessary.
Water or fuel in crankcase	Your authorized dealer can assist.
Low battery voltage	Recharge the battery to 12.8 VDC.
Mechanical failure	Your authorized dealer can assist.

ENGINE BACKFIRES

POSSIBLE CAUSE	SOLUTION
Weak spark from spark plug	Inspect, clean and/or replace spark plug
Incorrect spark plug gap or heat range	Set gap to specs or replace plug
Old or non-recommended fuel	Replace with fresh recommended fuel
Incorrectly installed spark plug wires	Your authorized dealer can assist

POSSIBLE CAUSE	SOLUTION
Mechanical failure	Your authorized dealer can assist
Loose ignition connections	Check all connections and tighten
Water present in fuel	Replace with fresh recommended fuel

ENGINE PINGS OR KNOCKS

POSSIBLE CAUSE	SOLUTION
Poor quality or low octane fuel	Replace with recommended fuel
Incorrect spark plug gap or heat range	Set gap to specs or replace plug

ENGINE RUNS IRREGULARLY, STALLS OR MISFIRES

POSSIBLE CAUSE	SOLUTION
Fouled or defective spark plug	Inspect, clean and/or replace spark plug
Worn or defective spark plug wires	Your authorized dealer can assist
Incorrect spark plug gap or heat range	Set gap to specs or replace plug
Loose ignition connections	Check all connections and tighten
Water present in fuel	Replace with new fuel
Low battery voltage	Recharge battery to 12.8 VDC
Incorrect fuel	Replace with recommended fuel
Clogged air filter	Inspect and clean or replace
Clogged intake pre-filter	Inspect and clean (with soapy water) or replace
Other mechanical failure	Your authorized dealer can assist

TROUBLESHOOTING

ENGINE STOPS OR LOSES POWER

POSSIBLE CAUSE	SOLUTION
Out of fuel	Refuel
Water is present in fuel	Replace with new fuel
Fouled or defective spark plug	Inspect, clean and/or replace spark plug
Worn or defective spark plug wires	Your POLARIS dealer, or other qualified person, can assist
Incorrect spark plug gap or heat range	Set gap to specs or replace plug
Loose ignition connections	Check all connections and tighten
Low battery voltage	Recharge the battery to 12.8 VDC
Incorrect fuel	Replace with fresh recommended fuel
Clogged air filter	Inspect and clean or replace
Throttle release switch malfunction	Your POLARIS dealer, or other qualified person, can assist
Other mechanical failure	Your POLARIS dealer, or other qualified person, can assist
Overheated engine	Clean radiator screen and core, clean engine exterior. Your POLARIS dealer, or other qualified person, can assist

WARRANTY

LIMITED WARRANTY

POLARIS Industries Inc., 2100 Highway 55, Medina, MN 55340 (POLARIS) gives a SIX MONTH LIMITED WARRANTY on all components of your POLARIS vehicle against defects in material or workmanship. Laws and regulations in your jurisdiction may give extra protection. POLARIS further warrants that the spark arrester in this product will meet the efficiency requirements of USFS standard 5100-1D for at least 1000 hours when subjected to normal use and when maintenance and installation are in accordance with POLARIS recommendations.

This warranty covers parts and labor charges for repair or replacement of defective parts and begins on the date of purchase by the original retail purchaser. The duration of this warranty may vary by international region based upon local laws and regulations.

REGISTRATION

At the time of sale, the Warranty Registration Form must be completed by your dealer and submitted to POLARIS within ten days of purchase. Upon receipt of this registration, POLARIS will record the registration for warranty. No verification of registration will be sent to the purchaser as the copy of the Warranty Registration Form will be your proof of warranty coverage. If you have not signed the original registration and received the customer copy, please contact your dealer immediately. Initial dealer preparation and set-up of your vehicle is very important in ensuring trouble-free operation.

WARRANTY COVERAGE AND EXCLUSIONS

LIMITATIONS OF WARRANTIES AND REMEDIES

This POLARIS limited warranty excludes any failures that are not caused by a defect in material or workmanship. **THIS WARRANTY DOES NOT COVER CLAIMS OF DEFECTIVE DESIGN.** This warranty also does not cover acts of God, accidental damage, normal wear and tear, abuse or improper handling. This warranty also does not cover any damage to any vehicle, component, or part as a result of being structurally altered or electrically, modified, neglected, improperly maintained or used for racing, competition or purposes other than for which it was designed.

This warranty excludes damages or failures resulting from improper lubrication; surface imperfections caused by external stress, heat, cold or contamination; operator error or abuse; improper component alignment, tension, adjustment; snow, water, dirt or other foreign substance ingestion/contamination; improper maintenance; modified components; use of aftermarket or unapproved components, accessories, or attachments; use of unapproved software or calibration; unauthorized repairs; or repairs made after the warranty period expires or by an unauthorized repair center.

This warranty excludes the expected reduction in range or capacity that the high-voltage battery pack may experience as a result of time and usage. However, a high-voltage battery pack that exhibits a capacity reduction in excess of 20% of the published nominal capacity is covered under the limited warranty. The reduction would need to be verified by an authorized dealer by checking the battery management system (BMS) log data.

This warranty excludes non-recoverable high-voltage battery packs. It is the owner's responsibility to ensure the state of charge (SoC) of the high-voltage battery is maintained properly and never fully depleted. If the high-voltage battery charge becomes fully depleted, the high-voltage battery can cease operating permanently (also known as non-recoverable)

This warranty excludes damages or failures caused by abuse, accident, fire, or any other cause other than a defect in materials or workmanship and provides no coverage for consumable components, general wear items, or any parts exposed to friction surfaces, stresses, environmental conditions and/or contamination for which they were not designed or not intended, including but not limited to the following items:

- Wheels and tires
- Suspension components
- Brake components
- Seat components
- Steering components
- 12-Volt Battery
- Light bulbs/Sealed beam lamps
- Lubricants
- Finished and unfinished surfaces
- Bushings
- Hydraulic components and fluids
- Circuit breakers/Fuses
- Electronic components
- Sealants
- Coolants
- Bearings

LUBRICANTS AND FLUIDS

1. Mixing oil brands or using non-recommended oil may cause engine damage. We recommend the use of POLARIS engine oil.
2. Damage or failure resulting from the use of non-recommended lubricants or fluids is not covered by this warranty.

This warranty provides no coverage for personal loss or expense, including mileage, transportation costs, hotels, meals, shipping or handling fees, product pick-up or delivery, replacement rentals, loss of product use, loss of profits, or loss of vacation or personal time.

THE EXCLUSIVE REMEDY FOR BREACH OF THIS WARRANTY SHALL BE, AT POLARIS' OPTION, REPAIR OR REPLACEMENT OF ANY DEFECTIVE MATERIALS, COMPONENTS, OR PRODUCTS. THE REMEDIES SET FORTH IN THIS WARRANTY ARE THE ONLY REMEDIES AVAILABLE TO ANY PERSON FOR BREACH OF THIS WARRANTY. POLARIS SHALL HAVE NO LIABILITY TO ANY PERSON FOR INCIDENTAL, CONSEQUENTIAL OR SPECIAL DAMAGES OF ANY DESCRIPTION, WHETHER ARISING OUT OF EXPRESS OR IMPLIED WARRANTY OR ANY OTHER CONTRACT, NEGLIGENCE, OR OTHER TORT OR OTHERWISE. THIS EXCLUSION OF CONSEQUENTIAL, INCIDENTAL, AND SPECIAL DAMAGES IS INDEPENDENT FROM AND SHALL SURVIVE ANY FINDING THAT THE EXCLUSIVE REMEDY FAILED OF ITS ESSENTIAL PURPOSE.

THE IMPLIED WARRANTY OF FITNESS FOR A PARTICULAR PURPOSE IS EXCLUDED FROM THIS LIMITED WARRANTY. ALL OTHER IMPLIED WARRANTIES (INCLUDING BUT NOT LIMITED TO THE IMPLIED WARRANTY OF MERCHANTABILITY) ARE LIMITED IN DURATION TO THE ABOVE SIX MONTH WARRANTY PERIOD. POLARIS DISCLAIMS ALL EXPRESS WARRANTIES NOT STATED IN THIS WARRANTY. SOME STATES DO NOT PERMIT THE EXCLUSION OR LIMITATION OF INCIDENTAL OR CONSEQUENTIAL DAMAGES OR ALLOW LIMITATIONS ON THE DURATION OF IMPLIED WARRANTIES, SO THE ABOVE LIMITATIONS MAY NOT APPLY TO YOU IF INCONSISTENT WITH CONTROLLING STATE LAW.

WARRANTY

HOW TO OBTAIN WARRANTY SERVICE

If your vehicle requires warranty service, you must take it to a POLARIS Servicing Dealer. When requesting warranty service you must present your copy of the Warranty Registration Form to the dealer. (THE COST OF TRANSPORTATION TO AND FROM THE DEALER IS YOUR RESPONSIBILITY.) POLARIS suggests that you use your original selling dealer; however, you may use any POLARIS Servicing Dealer to perform warranty service.

IN THE COUNTRY WHERE YOUR PRODUCT WAS PURCHASED:

You are responsible for presenting your vehicle to an authorized POLARIS dealer as soon as a problem exists. The warranty repairs should be completed in a reasonable amount of time, not to exceed 30 days. However, any damage caused to the product by you or any non-authorized third party may void this warranty. Warranty or Service Bulletin repairs must be done by an authorized POLARIS dealer, or other qualified person authorized by POLARIS.

OUTSIDE THE COUNTRY WHERE YOUR PRODUCT WAS PURCHASED:

If you are traveling temporarily outside the country where your product was purchased, you should take your product to an authorized POLARIS dealer, or other qualified person authorized by POLARIS. You must show the dealer photo identification from the country of the selling dealer's authorized location as proof of residence. Upon residence verification, the servicing dealer will be authorized to perform the warranty repair.

IF YOU MOVE:

If you move to another country, be sure to contact POLARIS Customer Assistance and the customs department of the destination country before you move. Product importation rules vary considerably from country to country. You may be required to present documentation of your move to POLARIS in order to continue your warranty coverage. You may also be required to obtain documentation from POLARIS to register your product in your new country. We recommend that you register your product at a local authorized POLARIS dealer promptly after you move.

IF YOU PURCHASE FROM A PRIVATE PARTY:

If you purchase a POLARIS product from a private party, to be kept and used outside of the country in which the product was originally purchased, all warranty coverage will be denied. However, we encourage you to promptly register your product at your local authorized POLARIS dealer to receive safety information and notice regarding your product.

EXPORTED PRODUCTS

EXCEPT WHERE SPECIFICALLY REQUIRED BY LAW, THERE IS NO WARRANTY OR SERVICE BULLETIN COVERAGE ON THIS PRODUCT IF IT IS SOLD OUTSIDE THE COUNTRY OF THE SELLING DEALER'S

AUTHORIZED LOCATION. This policy does not apply to products that have received authorization for export from POLARIS. Dealers may not give authorization for export. You should consult an authorized dealer to determine this product's warranty or service coverage if you have any questions. This policy does not apply to products registered to government officials or military personnel on assignment outside the country of the selling dealer's authorized location. This policy does not apply to Safety Bulletins

NOTICE

If vehicle is equipped with windshield, remove windshield, or tilt windshield up. Remove any hardware attached to ROPS right-hand A-pillar.

NOTICE

If your product is registered outside of the country where it was purchased and you have not followed the procedure set above, your product will no longer be eligible for warranty or service bulletin coverage of any kind, other than safety recalls. Products registered to government officials or military personnel on assignment outside of the country where the product was purchased will continue to be covered by the Limited Warranty.

Please work with your dealer to resolve any warranty issues. Dealership contacts can be found via this website, if needed:

www.polaris.com/en-us/contact

Should your dealer require any additional assistance, they will contact the appropriate person at POLARIS.

This warranty gives you specific legal rights, and you may also have other rights which vary from state to state or in different countries. If any of the above terms are void because of federal, state, local law, all other warranty terms will remain in effect.

For questions call POLARIS Owner Connections:

United States & Canada: 1-800-POLARIS (1-800-765-2747)

French: 1-800-268-6334

To report a safety defect to Transport Canada, you may either fill out an online defect complaint form at their website:

English: <http://www.tc.gc.ca/recalls>

French: <http://www.tc.gc.ca/rappels>

WARRANTY

Or contact their Defect Investigations and Recalls Division by calling toll-free 1-800-333-0510 (Canada) or 819-420-4300 (Ottawa-Gatineau area / International).

U.S.A. EPA EMISSIONS LIMITED WARRANTY

This emissions limited warranty is in addition to the POLARIS standard limited warranty for your vehicle. POLARIS Industries Inc. warrants that at the time it is first purchased, this emissions-certified vehicle is designed, built and equipped so it conforms with applicable U.S. Environmental Protection Agency emission regulations. POLARIS warrants that the vehicle is free from defects in materials and workmanship that would cause it to fail to meet these regulations.

The warranty period for off road vehicles 100cc or greater emissions-certified vehicles starts on the date of purchase by original retail purchaser and continues for a period of 500 hours of engine operation, 5000 kilometers (3100 miles) of vehicle travel, or 30 calendar months from the date of purchase, whichever comes first. The warranty period for ATVs less than 100cc emissions-certified vehicles starts on the date of purchase by original retail purchaser and continues for a period of 250 hours of engine operation, 2500 kilometers (1550 miles) of vehicle travel, or 30 calendar months from the date of purchase, whichever comes first. This EPA emissions warranty period is extended for at least as long as the standard factory warranty that Polaris provides on the vehicle as a whole. The EPA emissions warranty period does not further extend if you purchase additional warranty coverage in the form of a service contract or other paid warranty extension, but emission-related parts may be covered subject to the terms of any such paid service contract or paid warranty extension

This emissions limited warranty covers components whose failure increases the vehicle's regulated emissions, and it covers components of systems whose only purpose is to control emissions. Repairing or replacing other components not covered by this warranty is the responsibility of the vehicle owner. This emissions limited warranty does not cover components whose failure does not increase the vehicle's regulated emissions.

For exhaust emissions, emission-related components include any engine parts related to the following systems:

- Air-induction system
- Fuel system
- Ignition system
- Exhaust gas recirculation systems

The following parts are also considered emission-related components for exhaust emissions:

- Aftertreatment devices
- Crankcase ventilation valves
- Sensors
- Electronic control units

The following parts are considered emission-related components for evaporative emissions:

- Fuel Tank
- Fuel Cap
- Fuel Line
- Fuel Line Fittings
- Clamps*
- Pressure Relief Valves*
- Control Valves*
- Control Solenoids*
- Electronic Controls*
- Vacuum Control Diaphragms*
- Control Cables*
- Control Linkages*
- Purge Valves
- Vapor Hoses
- Liquid/Vapor Separator
- Carbon Canister
- Canister Mounting Brackets
- EFI Purge Port Connector

*As related to the evaporative emission control system.

Emission-related components also include any other part whose only purpose is to reduce emissions or whose failure will increase emissions without significantly degrading engine/equipment performance. The exclusive remedy for breach of this limited warranty shall be, at the exclusive option of POLARIS, repair or replacement of any defective materials, components or products. THE REMEDIES SET FORTH IN THIS LIMITED WARRANTY ARE THE ONLY REMEDIES AVAILABLE TO ANY PERSON FOR BREACH OF THIS WARRANTY. POLARIS SHALL HAVE NO LIABILITY TO ANY PERSON FOR INCIDENTAL, CONSEQUENTIAL OR SPECIAL DAMAGES OF ANY DESCRIPTION, WHETHER ARISING OUT OF EXPRESS OR IMPLIED WARRANTY OR ANY OTHER CONTRACT, NEGLIGENCE OR OTHER TORT OR OTHERWISE. THIS EXCLUSION OF CONSEQUENTIAL, INCIDENTAL, AND SPECIAL DAMAGES IS INDEPENDENT FROM AND SHALL SURVIVE ANY FINDING THAT THE EXCLUSIVE REMEDY FAILED OF ITS ESSENTIAL PURPOSE.

ALL IMPLIED WARRANTIES (INCLUDING BUT NOT LIMITED TO ANY IMPLIED WARRANTIES OF MERCHANTABILITY AND FITNESS FOR A PARTICULAR PURPOSE) ARE LIMITED IN DURATION TO THE WARRANTY PERIOD DESCRIBED HEREIN. POLARIS DISCLAIMS ALL EXPRESS WARRANTIES NOT STATED IN THIS WARRANTY. Some states do not allow limitations on how long an implied warranty lasts, so the above limitation may not apply if it is inconsistent with the controlling state law.

This limited warranty excludes failures not caused by a defect in material or workmanship. This limited warranty does not cover damage due to accidents, abuse or improper handling, maintenance or use. This limited warranty also does not cover damage to any engine as a result of being structurally altered, or when the vehicle has been used in racing competition. This limited warranty also does not cover physical damage, corrosion or defects caused by fire, explosions or other similar causes beyond the control of POLARIS.

WARRANTY

Owners are responsible for performing the scheduled maintenance identified in the owner's manual. POLARIS may deny warranty claims for failures that have been caused by the owner's or operator's improper maintenance or use, by accidents for which POLARIS has no responsibility, or by acts of God.

Any qualified repair shop or person may maintain, replace, or repair the emission control devices or systems on your vehicle. An authorized POLARIS dealer, or other qualified person, can perform any service that may be necessary for your vehicle. POLARIS also recommends POLARIS parts, however equivalent parts may be used for such service. It is a potential violation of the Clean Air Act if a part supplied by an aftermarket parts manufacturer reduces the effectiveness of the vehicle's emission controls. Tampering with emission controls is prohibited by federal law.

CALIFORNIA RESIDENTS

Certain POLARIS Off-Road Vehicles are available in 49-state and 50-state versions. Only the 50-state models are certified for sale in California. The 50-state models available for sale in California are identified by the letter “B” in the ninth position of the model number (e.g., R16RTE87B). The POLARIS 50-state models are designed and built with features such as a reduced cargo box capacity. Any modifications to these features may be a violation of the applicable California regulations and may void this limited emissions warranty offered by the manufacturer.

POLARIS Industries Inc. warrants that at the time it is purchased, this vehicle is:

1. Designed, built, and equipped so as to conform, at the time of sale, with all applicable California evaporative emissions regulations.
2. Free from defects in materials and workmanship that may cause the failure of a warranted part as defined in California evaporative emissions regulations. All replacement parts must be identical in all material respects to that part as described in the OHRV manufacturer’s Executive Order of Certification application.

The California evaporative emissions control system limited warranty statement below applies to your Off Highway Recreational Vehicle in California if the vehicle is equipped with an evaporative emission control system and is labeled with a Vehicle Evaporative Emissions Control Information label indicating that the vehicle conforms to California evaporative emissions regulations applicable to new off-road sport vehicles, all-terrain vehicles, or off-road utility vehicles. These vehicles are referred to as “OHRV-EVAP” below.

CALIFORNIA EMISSION CONTROL WARRANTY STATEMENT YOUR WARRANTY RIGHTS AND OBLIGATIONS

The California Air Resources Board and Polaris Industries Inc. are pleased to explain the emission control system warranty on your model year 2018 and newer Off Highway Recreational Vehicle. In California, new off-highway recreational vehicles must be designed, built and equipped to meet the State’s stringent anti-smog standards. Polaris must warrant the emission control system on your OHRV-EVAP for the periods of time listed below provided there has been no abuse, neglect or improper maintenance of your OHRV-EVAP.

Your emission control system may include parts such as the carburetor or fuel injection system, fuel tank, fuel hoses, carbon canister, engine computer and Evaporative Emissions Control System parts listed in the U.S.A. EPA Emissions Limited Warranty. Also included may be hoses, belts, connectors and other emission-related assemblies. Where a warrantable condition exists, Polaris will repair your OHRV-EVAP at no cost to you including diagnosis, parts and labor.

MANUFACTURER’S WARRANTY COVERAGE:

For model year 2018 and newer OHRV-EVAP models.

WARRANTY

For 30 months, or 2500 miles (4023 km), or 250 hours, whichever comes first, except for evaporative components over the OHRV high-priced warranty value, which is covered for 60 months, or 5000 miles (8047 km), or 500 hours, whichever comes first.

If any emission-related part on your OHRV-EVAP is defective, the part will be repaired or replaced by Polaris.

OWNER'S WARRANTY RESPONSIBILITIES:

As the OHRV-EVAP owner, you are responsible for the performance of the required maintenance listed in your owner's manual. Polaris recommends that you retain all receipts covering maintenance on your OHRV-EVAP, but Polaris cannot deny warranty solely for the lack of receipts or for your failure to ensure the performance of a scheduled maintenance.

As an owner you are responsible for presenting your OHRV-EVAP to a Polaris dealer as soon as a problem exists. The warranty repairs should be completed in a reasonable amount of time, not to exceed 30 days.

As an OHRV-EVAP owner, you should also be aware that Polaris may deny you warranty coverage if your OHRV-EVAP or a part has failed due to abuse, neglect, improper maintenance or unapproved modifications.

ADD-ON OR MODIFIED PARTS

An add-on or modified part must be compliant with applicable CARB emission control standards. A violation of this requirement is punishable by civil and/or criminal punishment.

If you have any questions regarding your warranty rights and responsibilities, you should contact Polaris Customer Assistance at 1-800-POLARIS (1-800-765-2747) or the California Air Resources Board at 9528 Telstar Avenue, El Monte, CA 91731.

United States & Canada: 1-800-POLARIS (1-800-765-2747)

French: 1-800-268-6334

CALIFORNIA EMISSIONS

How the California Emissions Warranty on Evaporative Emission Parts Must Function as Prescribed in 13 CCR § 2419.1

(1) Any warranted part which is not scheduled for replacement as part of maintenance in the Owner's Manual must be warranted for the warranty period. If any such part fails during the warranty period, it must be repaired or replaced by POLARIS according to subdivision (4) below. Any such part repaired or replaced under warranty must be fully warranted.

- (2) Any warranted part which is scheduled only for regular inspection in the Owner's Manual must be warranted for the warranty period. A statement in such written instructions to the effect of "repair or replace as necessary" must not reduce the period of warranty coverage. Any such part repaired or replaced under warranty must be warranted for the remaining warranty period.
- (3) Any warranted part which is scheduled for replacement as part of maintenance in the Owner's Manual must be warranted for the period of time prior to the first scheduled replacement point for that part. If the part fails before the first scheduled replacement point, the part must be repaired or replaced by POLARIS according to subdivision (4). Any such part repaired or replaced under warranty must be warranted for the remainder of the period prior to the first scheduled replacement point for the part.
- (4) Repair or replacement of any warranted part under the warranty provisions of this Article must be performed at no charge to the OHRV owner, at a warranty station, except in the case of a temporary repair when a warranted part or a warranty station is not reasonably available to the OHRV owner. In the event a temporary repair is permitted according to subdivision (8) below, repairs may be performed at any available service establishment, or by the owner, using any replacement part. POLARIS must reimburse the owner for his or her expenses including diagnostic charges for such temporary repair or replacement, not to exceed POLARIS' suggested retail price for all warranted parts replaced and labor charges based on the POLARIS recommended time allowance for the warranty repair and the geographically appropriate hourly labor rate.
- (5) Notwithstanding the provisions of subdivision (4) above, warranty services or repairs must be provided at all POLARIS dealerships that are owned by POLARIS or franchised to service the subject OHRVs.
- (6) The OHRV owner must not be charged for diagnostic labor which leads to the determination that a warranted part is, in fact, defective, provided that such diagnostic work is performed at a warranty station.
- (7) POLARIS is liable for damages to other vehicle components proximately caused by a failure, under warranty, of any warranted part.
- (8) Throughout the OHRV's evaporative emissions warranty period, POLARIS must maintain a supply of warranted parts sufficient to meet the expected demand for such parts. The lack of availability of such parts or the incompleteness of repairs within a reasonable time period, not to exceed 30 days from the time the OHRV is initially presented to the warranty station for repair, will qualify the need for a temporary repair for purposes of subdivision (4).
- (9) Any replacement part designated by POLARIS may be used in warranty repairs provided without charge to the OHRV owner. Such use will not reduce the warranty obligations of POLARIS, except that POLARIS will not be liable under the provisions of this Article for repair or replacement of any replacement part which is not a warranted part (except as provided under subdivision (d)(7)).

WARRANTY

(10) Any add-on or modified part exempted by the Air Resources Board from the prohibitions of section 27156 of the California Vehicle Code may be used on an OHRV. Such use, in and of itself, will not be grounds for disallowing a warranty claim made under the provisions of this Article. POLARIS is not liable under the provisions of this Article to warrant failures of warranted parts caused by the use of an add-on or modified part(s) unless such part(s) are also warranted.

(11) Upon a request of the Executive Officer, POLARIS must provide any documents that describe the manufacturer's warranty procedures or policies.

(12) Any replacement part must not reduce the effectiveness of the OHRV emission control system. POLARIS must demonstrate that the applicable emission standards are being met when the replacement part(s) are installed on the OHRV. The demonstration of equivalence to applicable emission standards can be achieved through replacing the part(s) with the evaporative emissions control components the OHRV evaporative family was certified with; or, if unavailable, alternative parts may be installed if POLARIS can provide test data to verify the evaporative control system meets, at least, the OHRV EFEL.

Exclusion

Notwithstanding the provisions of subdivisions (1) - (12) above, the repair or replacement of any warranted part otherwise eligible for the California Warranty on Evaporative Emission Parts, is excluded from such warranty coverage if POLARIS can provide evidence to the California Air Resources Board Executive Officer, to the Executive Officer's satisfaction, that the OHRV has been abused, neglected, improperly maintained, or had unapproved modifications and that such abuse, neglect, improper maintenance, or unapproved modification, was the direct cause of the need for the repair or replacement of the part.

A	
Adding or Changing Coolant	81
Air Filter.....	86
Air Filter / Air Box.....	103
All Wheel Drive/Rear	
Differential System	56
Auxiliary Outlet.....	37
Axle and Wheel Nut Torque	
Specifications.....	93

B	
Battery	
Installation	97
Overview	97
Removal.....	97
Battery Maintenance	103
Battery Maintenance and	
Charging	99
Belt Life	62
Belt Replacement	83
Brake Fluid.....	89
Brake Inspection	90
Brake Pedal	38
Brakes	89
Braking	56
Break-in Period	53
Bumper Light Bar Switch (if	
equipped).....	37

C	
California Emissions.....	124
California Residents	123
Cargo	59
Cargo Box, Dumping	62
Check Engine Indicator.....	52
Clean the Exterior.....	103
Clutch Cover Warning.....	29
Clutching	108
Component Locations.....	33
Cooling System.....	81
Crankcase Emission Control	
System	65

D	
Display Units, Standard/Metric	50
Drive Belt Wear/Burn.....	111
Drivetrain Break-In.....	53
Drying the Transmission.....	84

E	
Electromagnetic Interference	65
Electronic Power Steering	41
Emissions Limited Warranty.....	120
Engine Backfires	112
Engine Break-In	53
Engine Doesn't Turn Over	112
Engine Oil.....	72
Engine Oil Change.....	74
Engine Oil Check.....	73
Engine Pings or Knocks	113
Engine Runs Irregularly, Stalls	
or Misfires	113
Engine Stopping.....	56
Engine Turns Over, Fails to	
Start.....	112
Error Codes, Engine.....	52
Exhaust Emission Control	
System	65
Exhaust System Warning	86
Exported Products	119

F	
Fan, Cooling.....	81
Filter Systems.....	86
Fluid Change	
Engine Oil.....	74
Front Gearcase	77
Main Gearcase	76
Transmission.....	76
Fluid Check	
Front Gearcase.....	77
Main Gearcase	76
Transmission.....	76
Fluid Level	
Engine Oil.....	73
Fluid Levels.....	104

Fluid Part Numbers	109
Fog the Engine	104
Fouled Plugs	80
Front Gearcase	77
Front/Rear Spring Preload	91
Fuel Cap	42
Fuel Recommendation	54
Fuel Stabilizer	103
Fuses	95

G

Gap, Spark Plug	79
Gear Selector	34
Gearcase Specification Chart	77
Gearcase, Front	77
Gearcases	76
Gears, Shifting	34

H

Hauling Cargo	59
Headlight Beam Adjustment	96
Headlight Replacement	95
Hitch	41
Hitch Weight	60
Hood	42
How To Obtain Warranty Service	118

I

Ignition Switch	35
Indicator Lamps	45
Instrument Cluster	43
Intake Screen	86

L

Labels	
Air Filter Caution	31
Light Switch	36
Lights	95
Limited Warranty	115

Load Capacity	59
Lubricants / Service Products	109
Lubrication Recommendations	70

M

Main Gearcase	76
Maintenance	
Periodic	67
Maintenance Chart	68
Maintenance Log	127
Metric Display	50
Mode Button	44

N

Near-field Communication (NFC)	9
Noise Emission Control System	65
Notice	119

O

Oil and Filter	103
Oil Change	
Engine	74
Front Gearcase	77
Main Gearcase	76
Transmission	76
Oil Level	
Engine	73
Front Gearcase	77
Main Gearcase	76
Transmission	76
Oil Recommendations	72
Operation on Public Lands in the U.S.A.	65

P

Part Numbers	109
Payload Warning / Shift Caution (7185784)	27
Periodic Maintenance Chart	67
Plug Gap	79

Plug Torque.....	79
Plugs, Fouled	80
Plugs, Spark.....	79
Polaris Products	109
POLARIS Variable Transmission System.....	83
Polishing the Vehicle	102
Power Steering	41
Power Steering Unit (Cleaning).....	85
Programmable Service Interval.....	51
PVT Break-in (Clutches/Belt)	54
PVT Drying	84
PVT Intake Screen.....	86

R

Radiator and Cooling Fan.....	81
Radiator Coolant Level	82
Radio Compliance Statements	10
Receiver Hitch	41
Registration, Warranty	115
Removal from Storage.....	105
Rider Information Center	46
Rollover Protective Structure (ROPS).....	41

S

Safety Driver and Passenger Qualifications	14
Driving Guidelines	20
Owner Requirements	13
Prepare Vehicle for the Ride	15
Prepare Yourself, Passengers, and Cargo for the Ride	18
Safety Labels.....	27
Safety Symbols	8
Safety Warnings.....	53
Seat Belt.....	39
Seat Removal	40
Shifter	34
Shock Compression	92
Signal Words	8
Spark Arrestor	86
Spark Plug Inspection.....	79

Spark Plug Recommendations	79
Specifications	107
Spring Preload	91
Stabilize the Fuel.....	103
Starting the Engine	55
Steering Wheel Inspection.....	85
Steering Wheel, Adjustment.....	41
Stopping the Engine.....	56
Storage	103
Storage Area	104
Storage Compartment Access	40
Storage Compartment, Under-Seat.....	40
Switches.....	35
Ignition Switch	35
Light Switch.....	36
Mode Button.....	44

T

Tachometer	44
Throttle Pedal	38
Tire Tread Depth	93
Tires	93
Torque, Axle Nuts	93
Torque, Spark Plug	79
Torque, Wheel Nut.....	93
Towing Loads	60
Towing the GENERAL	63
Trailer Hitch Bracket.....	41
Transmission.....	76
Drying	84
Oil	76
Transporting the GENERAL	106

U

Under-Seat Storage	40
--------------------------	----

V

Vehicle Identification Numbers	12
Vehicle Immersion	84

W

Warning Symbols	8
Washing the Vehicle.....	101
Water, Immersion of Vehicle.....	84
Welcome Page	3
Wet Fouled Plug.....	80
Wheel Installation	94
Wheel Nut Inspection	93
Wheel Nut Torque.....	93
Wheel Removal.....	93
Winch Switch (if equipped)	36



For your nearest Polaris dealer,
call 1-800-POLARIS (765-2747)
or visit www.polaris.com

Polaris Industries Inc.
2100 Highway 55
Medina, MN 55340



Part No. 9941301 Rev 01
Printed in USA