

2024



For Maintenance and Safety

# OWNER'S MANUAL

POLARIS XPEDITION ADV  
POLARIS XPEDITION ADV 5

**POLARIS**  
Think Outside



## WARNING

Operating, servicing, and maintaining a passenger vehicle or off-road vehicle can expose you to chemicals including engine exhaust, carbon monoxide, phthalates, and lead, which are known to the State of California to cause cancer and birth defects or other reproductive harm. To minimize exposure, avoid breathing exhaust, do not idle the engine except as necessary, service your vehicle in a well-ventilated area and wear gloves or wash your hands frequently when servicing your vehicle.

For more information go to [www.P65Warnings.ca.gov/passenger-vehicle](http://www.P65Warnings.ca.gov/passenger-vehicle).



*For videos and more information  
about a safe riding experience with  
your Polaris vehicle, scan this QR  
Code® with your smartphone  
or visit: [www.polaris.com/en-us/safety](http://www.polaris.com/en-us/safety)*



## ***2024 Owner's Manual***

***POLARIS XPEDITION ADV Premium***  
***POLARIS XPEDITION ADV Ultimate***  
***POLARIS XPEDITION ADV NorthStar***  
***POLARIS XPEDITION ADV 5 Premium***  
***POLARIS XPEDITION ADV 5 Ultimate***  
***POLARIS XPEDITION ADV 5 NorthStar***

Unless noted, trademarks are the property of Polaris Industries Inc.

Recreational Off-Highway Vehicle Association<sup>SM</sup> and ROHVA<sup>SM</sup> are service trademarks of Recreational Off-Highway Vehicle Association. BatteryMINDer<sup>®</sup> is a registered trademark of VDC Electronics Inc. Loctite<sup>®</sup> is a registered trademark of Henkel Corporation. NYOGEL<sup>®</sup> is a registered trademark of Nye Lubricants, Inc. WD-40<sup>®</sup> is registered to WD-40 Manufacturing Company. QR Code<sup>®</sup> is a registered trademark of DENSO WAVE INCORPORATED. Apple<sup>®</sup> and APP STORE<sup>®</sup> are registered trademarks of Apple Inc. ANSI<sup>®</sup> is a registered trademark of American National Standards Institute, Inc. Bluetooth<sup>®</sup> is a registered trademark of Bluetooth Sig, Inc. Google Play<sup>®</sup> is a registered trademark of Google, LLC. Sandisk<sup>®</sup> is a registered trademark of SANDISK LLC. exFAT<sup>®</sup> is a registered trademark of Microsoft Corporation. OSHA<sup>SM</sup> is a service trademark of the Occupational Safety and Health Administration, U. S. Dept. of Labor. Tread Lightly<sup>®</sup> is a registered trademark of the United States Department of Agriculture. Harman<sup>®</sup> and JBL<sup>®</sup> are registered trademarks of Harman International Industries, Incorporated.

Copyright 2023 Polaris Industries Inc. All information contained within this publication is based on the latest product information at the time of publication. Due to constant improvements in the design and quality of production components, some minor discrepancies may result between the actual vehicle and the information presented in this publication. Depictions and/or procedures in this publication are intended for reference use only. No liability can be accepted for omissions or inaccuracies. Any reprinting or reuse of the depictions and/or procedures contained within, whether whole or in part, is expressly prohibited.

The original instructions for this vehicle are in English. Other languages are provided as translations of the original instructions.

Printed in U.S.A.

9940600 R02



Thank you for purchasing a POLARIS vehicle, and welcome to our world-wide family of POLARIS enthusiasts. Be sure to visit us online at [www.polaris.com](http://www.polaris.com) for the latest news, new product introductions, upcoming events, career opportunities and more.

Here at POLARIS we proudly produce an exciting line of utility and recreational products. We believe POLARIS sets a standard of excellence for all utility and recreational vehicles manufactured in the world today. Many years of experience have gone into the engineering, design, and development of your POLARIS vehicle.

For safe and enjoyable operation of your vehicle, be sure to follow the instructions and recommendations in this owner's manual. Your manual contains instructions for minor maintenance, but information about major repairs is outlined in the POLARIS Service Manual and can be performed by a factory certified Master Service Dealer (MSD) technician.

Your POLARIS dealer knows your vehicle best and is interested in your total satisfaction. Your POLARIS dealership can perform all of your service needs during and after the warranty period.

For the most up-to-date owner's manual visit  
<https://www.polaris.com/en-us/owners-manuals>.

## SAFETY SYMBOLS AND SIGNAL WORDS

---

The following signal words and symbols appear throughout this manual and on your vehicle. Your safety is involved when these words and symbols are used. Become familiar with their meanings before reading the manual.

### DANGER

DANGER indicates a hazardous situation which, if not avoided, WILL result in death or serious injury.

### WARNING

WARNING indicates a hazardous situation which, if not avoided, COULD result in death or serious injury.

### CAUTION

CAUTION indicates a hazardous situation which, if not avoided, COULD result in minor to moderate injury.

### NOTICE

NOTICE provides key information by clarifying instructions.

### IMPORTANT

IMPORTANT provides key reminders during disassembly, assembly, and inspection of components.

The Prohibition Safety Sign indicates an action NOT to take in order to avoid a hazard.



The Mandatory Action Sign indicates an action that NEEDS to be taken to avoid a hazard.



## TABLE OF CONTENTS

---

<b>Introduction . . . . .</b>	<b>7</b>
<b>Safety . . . . .</b>	<b>9</b>
<b>Features and Controls . . . . .</b>	<b>37</b>
<b>Ride Command Display (if equipped) . . . . .</b>	<b>71</b>
<b>Operation . . . . .</b>	<b>85</b>
<b>Emission Control Systems . . . . .</b>	<b>95</b>
<b>Maintenance . . . . .</b>	<b>97</b>
<b>Specifications . . . . .</b>	<b>153</b>
<b>POLARIS Products . . . . .</b>	<b>165</b>
<b>Troubleshooting . . . . .</b>	<b>167</b>
<b>Warranty . . . . .</b>	<b>171</b>
<b>Maintenance Log . . . . .</b>	<b>183</b>





## INTRODUCTION

### TOOLS FOR SAFE RIDING

To safely operate this vehicle, it is important to become familiar with its features, controls, and characteristics. Review the Safety Briefings for this vehicle that apply to you:

- Operators
- Riders
- Owners
- Trailering the Vehicle
- Maintaining the Vehicle

Additionally, read the product safety labels on the vehicle and follow all rules and regulations concerning the operation of this vehicle in your area.

POLARIS recommends anyone who will be operating this vehicle to take a training course. ROHVA® (Recreational Off-Highway Vehicle Association) provides both an online safety e-course and a hands-on safety course. To access this training, visit [www.rohva.org](http://www.rohva.org).

Other sources of safety information include the POLARIS Safety Video. The POLARIS Help Center also has additional information: <https://polaris.com/en-us/self-help>

### VEHICLE TESTING

This Off-Road Vehicle was subjected to the following tests of the National Standard for Recreational Off-Highway Vehicles, ANSI®/ROHVA® 1-2016:

- Maximum Speed Capability
- Service Brake Performance
- Parking Brake/Mechanism Performance
- Lateral Stability
- Pitch Stability
- Vehicle Handling
- Roll Over Protective Structure (ROPS)
- Occupant Retention System (ORS)
- Sound Level Limits

## INTRODUCTION

---

### VEHICLE IDENTIFICATION NUMBERS

Record your vehicle's identification number ① and engine serial number ② in the spaces provided. Remove the spare key and store it in a safe place. The ignition switch must be replaced if all keys are lost.

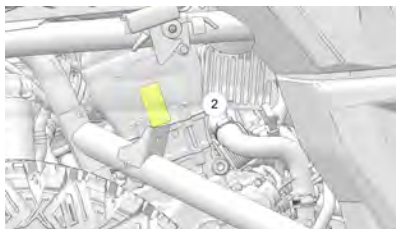
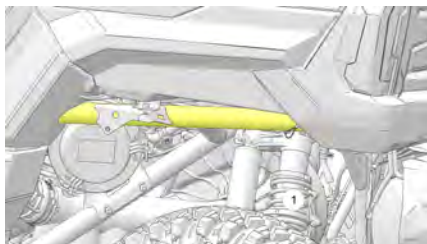

Vehicle Model Number:	
Vehicle Identification Number:	
Engine Serial Number:	
Personal PIN Security Code:	

---

## SAFETY

### OWNER REQUIREMENTS

**Improper use, maintenance, or modification of this vehicle can lead to serious injury or death.**

**Require proper use of your vehicle.** Do not allow anyone to operate your vehicle or ride as a passenger unless they are properly instructed and you are sure they are willing to ride responsibly. To prevent unauthorized use, always remove the ignition key when the vehicle is not in use.



**Any modifications or installation of non-POLARIS-approved accessories could increase the risk of injury.** While you may find aftermarket products similar in design and quality to POLARIS accessories, recognize that some aftermarket accessories or modifications are not suitable because of potential safety hazards to you or others. It is never appropriate to install any additional seating.

Check with the manufacturer to determine any potential effect of a modification or accessory on the safe use of your vehicle. You are responsible for injuries related to modifications to the vehicle. Modifications or accessories may:

- Damage machine components - especially modifications that increase speed or power.
- Make the vehicle less stable at higher speeds.
- Add weight, reducing the amount of cargo and total weight you can carry, and raise the vehicle's center of gravity.
- Overload the vehicle's electrical system capacity. Blowing a fuse may cause a loss of lights or engine power.
- Reduce the effectiveness of occupant protection systems, including the seatbelts and the Rollover Protective Structure (ROPS).
- Make it illegal to own or operate your vehicle. POLARIS-authorized spark arresters, mufflers, and emissions control components are mandatory for ownership or operation in many areas.
- Void your warranty.

**The vehicle ROPS, when used with the seat belts and doors, provides a structure to help protect occupants.** The structure will not protect occupants in all rollovers or accidents.

For more information about safety, contact an authorized dealer or visit the Polaris website at [www.polaris.com](http://www.polaris.com).

### DRIVER AND PASSENGER QUALIFICATIONS

**Make sure operators are 16 or older with a valid driver's license.** Just because a teenager has a license does not mean that they will make good judgments about driving and avoid risk taking.

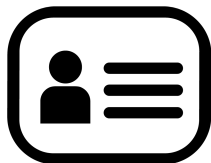

POLARIS recommends that you supervise younger drivers. Set rules and put limits on how, when, and where they are allowed to use this vehicle. For example, young drivers may need to have an adult in the vehicle with them and not be allowed to drive with their friends in the vehicle.

**Make sure all riders fit the vehicle.** Be sure that the driver and all passengers are able to:

- sit with their backs against their seat,
- adjust the seat belt to fit properly,
- have both feet flat on the floor, and
- have both hands on the steering wheel or on a passenger hand hold.

**Do not allow children who need child safety seats or booster seats to ride in the vehicle.** The vehicle is not designed to restrain automotive child safety seats.

**You are responsible for your passengers.** Be sure passengers are seated properly, belted, holding the passenger hand hold, and ready to brace. Unrestrained riders can fall out or be thrown around and from a moving vehicle.

**Every person must be properly seated and belted in their own seat.** Two people should never be belted into a single seat belt. People belted together can crash into one another in a collision and be seriously injured. Never carry passengers in the cargo bed as they could be thrown against or out of the vehicle or come into contact with moving parts.

**Do not let people drive or ride after using alcohol or drugs.**

## PREPARE VEHICLE FOR THE RIDE

**Before starting off, always perform the Pre-Ride Inspection.** Failure to inspect and verify that the vehicle is in safe operating condition increases the risk of an accident, which can lead to serious injury or death.



ITEM	REMARK	REFERENCE
Brake Fluid	Ensure proper level and condition	page 130
Front and rear suspension	Inspect	—
Front and rear shocks	Inspect	—
Steering	Ensure free operation	page 127
Tires	Inspect condition and pressure	page 25 page 134
Wheels/Lug Nuts	Inspect, ensure fastener tightness	page 134
Fuel and oil	Ensure proper levels and condition	page 104
Coolant	Ensure proper level and condition	page 117
Indicator lights/switches	Ensure proper operation	page 41 page 62
Air Filter	Inspect, replace as needed	page 128
Engine intake pre-filter	Inspect, clean	-
Headlights	Check operation	-
Brake lights/taillights	Check operation	-
Seat Belts	Check length of belt for damage, check latches for proper operation	page 48

## SAFETY

ITEM	REMARK	REFERENCE
Seat Latches (5 Passenger Models)	Ensure rear seat is secured.	page 53
Exhaust	Inspect spark arrester and clean if needed.	page 129
Vehicle Debris	Remove grass, leaves, and other flammable material or debris, especially near the exhaust system.	-
Lock adjustable steering wheel	Do not adjust the steering wheel while the vehicle is moving.	-
Alternator Belt (if equipped)	Inspect for cracks, damage. Replace, if necessary.	-

**Improper tire maintenance** can lead to loss of control and an accident, which could result in serious injury or death. To reduce your risk of injury:

- Maintain POLARIS recommended tire pressure. Check pressure before operating. Even if your vehicle has only been driven a short distance, the tire pressure readings can become higher.
- Make sure tire pressures match the specifications listed in the table below.
- Only use the size and type of tires specified for this vehicle.
- Do not operate your vehicle with worn or damaged tires.
- Always follow your tire manufacturer's instructions for maintenance.

MEASUREMENT	SPECIFICATION
Maximum Cargo Box Load	600 lbs (272 kg)
Tire Pressure in PSI (kPa) Premium/ Ultimate 2 Passenger Models Only	Premium/ Ultimate Models Front: 14 PSI (97 kPa) Rear: 18 PSI (124 kPa)
Tire Pressure in PSI (kPa) NorthStar 2 Passenger Models Only	NorthStar Models Front: 16 PSI (110 kPa) Rear: 22 PSI (152 kPa)
Tire Pressure in PSI (kPa) Premium/ Ultimate 5 Passenger Models Only	Premium/ Ultimate Models Front: 18 PSI (124 kPa) Rear: 22 PSI (152 kPa)
Tire Pressure in PSI (kPa) NorthStar 5 Passenger Models Only	NorthStar Models Front: 22 PSI (152 kPa) Rear: 26 PSI (179 kPa)
Maximum Weight Capacity Includes weight of operator, passenger, cargo, and accessories	2 Passenger- 1030 lb (467 kg)
	5 Passenger- 1160 lb (526 kg)

### PREPARE YOURSELF, PASSENGERS, AND CARGO FOR THE RIDE

**Wear an approved helmet.** Riding in this vehicle without wearing an approved helmet increases the risk of serious injury. For example, a helmet reduces your risk of injury from head strikes with the vehicle or other objects even if there is no crash.

Approved helmets in the USA and Canada bear a U.S. Department of Transportation (DOT) label. Approved helmets in Europe, Asia, and Oceania bear the ECE 22.05 label. The ECE mark consists of a circle surrounding the letter E, followed by the distinguishing number of the country which has granted approval. The approval number and serial number will also be displayed on the label.



**Use shatterproof goggles or a shatterproof helmet face shield.** Such protective eyewear may reduce the risk of foreign material getting in your eyes and help prevent loss of vision.

POLARIS recommends wearing approved Personal Protective Equipment (PPE) that have markings indicating they are designed to standards such as:

- VESC 8
- V-8
- Z87.1
- CE



**Additional protective clothing and gear** that may be appropriate for your riding conditions includes:

- Always wear shoes when operating. Consider wearing sturdy over-the-ankle boots suitable for the terrain you will be riding in.
- Full-finger gloves can protect against wind, sun, cold, and objects. Choose gloves that fit snugly and allow fingers to move freely and grip on the steering wheel or hand holds.
- Consider long sleeves and long pants to help protect arms and legs.
- Long-term exposure to wind and engine noise can cause permanent hearing loss. Properly worn hearing protective devices such as earplugs can help prevent hearing loss. Check local laws or the rules of the riding area you are in before wearing hearing protection to make sure its use is permitted.



**Always stay completely inside the vehicle and hold the steering wheel or hand holds.** Body parts outside of the vehicle can be struck by passing objects or crushed during a rollover. Do not put any part of your body outside of the vehicle for any reason. Do not hold onto the ROPS frame or put any part of your body on the door.

When transporting vehicle in non-enclosed trailer, vehicle must **FACE FORWARD**. Windshield and all windows, doors, and rear liftgate must be **FULLY CLOSED** and **LATCHED**. Failure to comply may allow airflow, vibration, or other factors to separate the windshield, doors, or rear liftgate from vehicle and cause an accident, resulting in serious injury or death.

**Be sure riders pay attention and plan ahead.** If you think or feel the vehicle may tip or roll, reduce your risk of injury:

- Keep a firm grip on the steering wheel or hand holds and brace yourself.
- Do not put any part of your body outside of the vehicle for any reason.

**This vehicle is not designed to carry unrestrained pets.** An unrestrained pet can be thrown about and injure riders, even during normal operation. When transporting pets, use a pet crate suitable for off-road use that is secured to the vehicle.

**Fuels such as gasoline can be extremely flammable.** To reduce the risk of serious injury or death, never carry fuel or other flammable liquids on this vehicle. Rollovers, crashes, rough riding, or changes in elevation or temperature may lead to fuel spilling or vapor release from portable containers. Hot vehicle parts can cause fires, even after the engine has been turned off.

**Never exceed vehicle weight capacities.** The vehicle's maximum weight capacity (including riders, cargo, and accessories) is 1030 lb. (467 kg) (two passenger) / 1160 lb. (526 kg) (five passenger) total. The cargo box can support up to 600 bs. (272 kg) of that total. When more rider weight is added, cargo weight may need to be eliminated to stay under the 1030 lb. (467 kg) (two passenger) / 1160 lb. (526 kg) (5 passenger) limit. Overloading the vehicle or carrying cargo improperly will cause changes in stability and handling, which could cause loss of control or an accident.

**Secure cargo in the cargo box as far forward, centered and as low as possible.** When cargo cannot be positioned and secured in this way, operate with extra caution. Unsecured cargo can strike and injure riders, affect vehicle handling, and result in loss of control.

**Cargo on the roof will raise the center of gravity.** The weight of cargo changes vehicle braking, handling, and stability. To avoid loss of control, turn gradually, operate at slower speeds, and avoid rougher or steeper terrain.

**The weight of riders and cargo changes vehicle braking, handling, and stability.** To avoid loss of control, turn gradually, operate at slower speeds, and avoid rougher or steeper terrain.

## DRIVING GUIDELINES

**Drive Responsibly.** This vehicle has higher ground clearance and other features to handle rugged terrain. It can be overturned in situations where some other vehicles may not. Abrupt maneuvers or aggressive driving, even on flat, open areas, can cause loss of control, rollovers, severe injury or death. To avoid loss of control and rollovers:



- Avoid abrupt maneuvers, sideways sliding, skidding, or fishtailing, and never do donuts.
- Slow down before entering turn.
- Avoid hard acceleration when turning, even from a stop.

### High speed off-road operation

Driving off-road vehicles to test the limits of your skills or abilities can be very dangerous to you, passengers, and bystanders. Basic skills for driving a car, ATV, or other off-road vehicles do not equip drivers to safely attempt high speed off-road operation. Develop your skill gradually through training, practice, and experience with the various driving modes of this vehicle and the terrain in which you are operating. Always do a low speed reconnaissance run (prerun) to become aware of anything you may encounter.

High speed off-road operation can lead to loss of control, crashes, or hard landings that can seriously injure occupants (even without rolling the vehicle or damaging it).

If you plan on using the vehicle for high speed, off-road competition, additional safety equipment may be necessary. Check the rules that apply to your competition.

### Do not go over jumps — going airborne can lead to serious injury or death.

Going airborne can cause loss of control, rollovers, or crashing into the ground and may damage the vehicle. Even without crashing, landings can be hard enough to cause any vehicle suspension to fully compress (e.g., bottom out). Serious injuries, including spinal injuries, can occur even if riders are properly harnessed, wearing helmets and the vehicle is not damaged and remains upright.

You may encounter slopes, "jumps", or other terrain features that could send the vehicle airborne, depending on your speed. These may be defectively designed, poorly maintained, or not suitable for this vehicle. Slow down, use extra care, and avoid going airborne. Never take this vehicle over jumps.

Watching someone else go over a jump or go airborne does not mean you can safely do so. Polaris cannot determine whether any jump you may encounter is appropriate for this vehicle. Any jump, even a small one, could be poorly maintained, designed, or not suitable for this vehicle and may cause serious injury or death.



**Plan for hills, rough terrain, ruts, and other changes in traction and terrain.**

Proceed slowly and with extra care on unfamiliar terrain. Avoid paved surfaces. Sudden changes in terrain such as holes, depressions, banks, softer or harder ground, or other irregularities may cause loss of control or rollover. Give yourself time to react to rocks, bumps, or holes that may be hard to see. Operating in deep snow or tall grass may make it harder to see obstacles.

If you cannot go around an obstacle, such as a fallen tree or a ditch, stop the vehicle in a safe place. Get out to inspect the area thoroughly. Look from both your approach side and exit side. If you are reasonably confident you can continue safely, choose the path that will allow you to go straight over the obstacle to minimize the vehicle tipping sideways. Go only fast enough to maintain your momentum, but still give yourself plenty of time to react to changes in conditions. If there is any question about your ability to maneuver safely over the obstacle, you should turn around if the ground is flat and you have the room, or back up until you find a less difficult path.

Abrupt application of the accelerator pedal can cause the tires to lose traction, reducing control of the vehicle and increasing the possibility of an accident, especially while on sloped terrain or while crossing obstacles such as rocks or logs.

**Avoid Operating on Public Roads (Paved or Otherwise).** This vehicle does not have highway safety features that on-road vehicles may have (air bags, anti-lock brakes, stability control, etc.). If another vehicle collides with you, the likelihood of a serious injury or death may be greater. Also, you may not be able to avoid a crash or rollover if you make sudden or abrupt maneuvers such as swerving or emergency braking.

While it may be legal to drive on some public roads, it is recommended that you avoid on-road operation. If you must drive on-road, drive slowly and defensively. Use extra care. You may also need to make vehicle modifications to comply with state or local laws. In addition, refer to tire manufacturer's instructions or limitations for on-road operation, including speed limits and premature tire wear.

## SAFETY

---

**Improperly operating on hills can cause loss of control, rollover, or accident**, which can lead to serious injury or death. Use extra care when operating on hills. Plan for rough terrain, ruts, and other changes in traction and terrain.

### **Driving up hills**

Check the terrain before ascending a hill and make sure it is not too slippery or loose. Engage all-wheel drive for hills. Drive straight uphill, keeping speed and throttle steady. Avoid steep hills which can cause the vehicle to overturn.

### **Recovering from stalling on a hill**

If the vehicle loses forward speed, apply the brakes gradually and stop. Do not attempt to turn the vehicle around. Instead, shift to reverse and allow the vehicle to slowly roll straight downhill. Apply light brake pressure to control speed.

### **Overtopping a hill**

Slow down when you reach the crest of a hill. Never blindly go over the crest of a hill or a drop off at high speed. An obstacle, a sharp drop, or another vehicle or person could be on the other side of the hill.

### **Driving down hills**

Check the terrain before descending a hill and make sure it is not too slippery or loose. Engage all-wheel drive and proceed slowly, applying the brakes lightly. Never descend a hill with the transmission in neutral or if the engine is turned off.

### **Avoid side hilling (riding across slopes)**

If unavoidable, proceed slowly and with extra caution. Avoid obstacles and changes in terrain that could cause the vehicle to tip or slide. If it feels like the vehicle begins to tip or slide, immediately turn downhill.

### **Riding near wooded areas or brush**

Use extra caution when operating near trees, particularly when operating on narrow trails. Tree branches or brush can be driven into the cab striking or stabbing occupants.



### **Riding in snow**

Always keep the brake and accelerator pedals free of snow and ice. Apply the brakes frequently to prevent ice or snow accumulation on the brake pads which can reduce brake performance.

### **Riding on ice**

Never operate the vehicle on a frozen body of water unless you have verified that the ice can support the weight of the vehicle. Severe injury or death can result if the vehicle falls through the ice.

**Riding in water / Falling into water**

Operating through deep or fast-flowing water can cause loss of traction, loss of control, overturning, or being swept away in water. You can be seriously injured or killed from entrapment and drowning. Never operate the vehicle in fast-flowing water or in water that exceeds the vehicles capabilities. Avoid sharp drop-offs and large rocks. Choose a path that provides an entrance and exit point with gradual inclines. Wet brakes may have reduced stopping ability. After leaving water, test the brakes. Apply them lightly several times while driving slowly. The friction will help dry out the pads. See *Water Fording Level* in this Owner's Manual for more information.

**Riding on sand dunes**

Use extra caution when operating on or near dunes. Be alert for changes in terrain. Never blindly go over the crest of a hill or a drop-off at high speed. An obstacle, a sharp drop, or another vehicle or a person could be on the other side of the hill.

**Riding in low-visibility conditions**

Use extra caution and drive slowly in conditions of reduced visibility such as fog, rain, and darkness.

**Plan ahead to avoid the need for evasive maneuvers, such as swerving.**

Hitting an obstacle — including wildlife — you are not ready for can be dangerous. Choosing to swerve instead can be even more dangerous because it can lead to loss of control, rollover, or collisions.

When operating in areas with possibility of wildlife appearing in your path, plan ahead to avoid swerving for animals if doing so could result in collisions or rollovers. Go slowly or avoid driving during seasons or times of day when animals such as deer are more likely to cross your path without warning.

**Avoid Collisions With Other Vehicles**

When following another vehicle or operating in the same area as others, keep a safe distance to avoid collisions. Allow extra space when sight distances are limited by dust, snow, curves, hills, or other conditions. Plan ahead to avoid having to swerve or leave the trail to avoid a collision.

On trails, be prepared to make space for other vehicles to pass. If you need to stop on a trail, move your vehicle to the edge of the path to allow others to pass safely.

**Correct a skid by turning the steering wheel in the direction of the skid.**

Never apply the brakes during a skid.

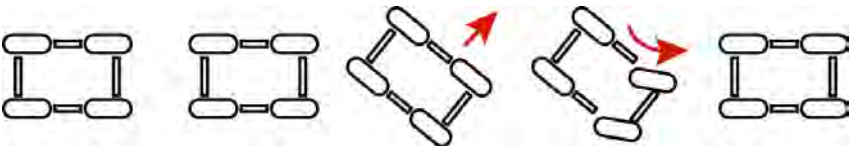

## SAFETY

---

If the vehicle begins to slide downhill or you feel it may tip, turn downhill immediately and stop. Maneuver slowly and carefully until you can drive straight downhill.

**Do not continue driving if your vehicle may be damaged or if you were in a crash or rollover.**

Operating the vehicle while damaged or after a crash or rollover can cause loss of control, rollover, or accident, which can lead to serious injury or death. If you cannot safely transport the vehicle on your own, contact a recovery and towing service.

After any crash, rollover, or other accident, have a POLARIS dealer inspect the vehicle for possible damage, including seat belts, ROPS, brakes, suspension, and steering systems.

Be prepared in case your vehicle becomes damaged or disabled, especially in remote areas. Consider in advance how to get help and stay safe until it arrives whenever you ride.

**There is a recovery tow loop ① at the front and back of the vehicle to attach a winch or strap.**

Use these loops to recover this vehicle if it is stuck, to pull it onto a tow truck, trailer, or to use this vehicle to recover another vehicle. These loops are for emergency recovery only and are not for towing vehicles to another location.

Improper recovery may lead to loss of control or vehicle damage. Only attach straps to specified locations. Do not attach to any other point on the vehicle. Only recover a vehicle of equal or lesser size and weight. When recovering a disabled vehicle, place the disabled vehicle's transmission in neutral. Do not move a disabled POLARIS XPEDITION faster than 10 mph (16 km/h).

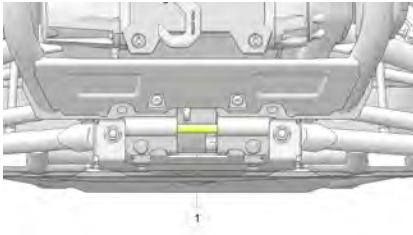

**Operating, Idling, Or Parking Near Combustible Materials**

Engine, exhaust, and other vehicle components can be very hot during and after use. Do not idle or park the vehicle over anything that could contact the exhaust system and catch on fire, such as tall grass, weeds, brush, leaves, debris, or other tall ground cover. Do not let mud, grass, or other debris accumulate on the engine or exhaust system. Inspect and remove as needed.

**Vehicle rollaway can cause serious injury or death.** This vehicle can roll whenever the gear selector is not in the PARK (P) position. Always shift to PARK (P) when stopping the engine or leaving the vehicle. When leaving the vehicle on an incline is unavoidable, use extra care. If leaving the vehicle unattended, block the rear wheels on the downhill side and keep children, pets, and others away from the gear selector.

**Before shifting into reverse, use extra care to make sure the area is clear of people or obstacles.** When it's safe to proceed, back slowly.

## SAFETY

---

**After operation, inspect the vehicle for damage and debris** to make sure the vehicle can be safely stored and operated again. Some things to inspect include:

- Debris that could catch fire, such as mud/grass near the engine or exhaust system
- Damage to the suspension, steering, or any other part of the vehicle
- Tire condition, such as tread and sidewall damage
- Shock absorber assembly condition

Be sure to have any issues checked and problems fixed before operating again.

**All engine exhaust contains carbon monoxide**, a deadly gas. Breathing carbon monoxide can cause headaches, dizziness, drowsiness, nausea, confusion, and eventually death. Carbon monoxide is a colorless, odorless, tasteless gas which may be present even if you do not see or smell any engine exhaust. Deadly levels of carbon monoxide can collect rapidly, and you can quickly be overcome and unable to save yourself. Also, deadly levels of carbon monoxide can linger for hours or days in enclosed or poorly ventilated areas. If you experience any symptoms of carbon monoxide poisoning, leave the area immediately, get fresh air, and **SEEK MEDICAL TREATMENT**.

- Do not run engine indoors. Even if you try to ventilate engine exhaust with fans or open windows and doors, carbon monoxide can rapidly reach dangerous levels.
- Do not run engine in poorly ventilated or partially enclosed areas such as barns, garages, or carports. If you start a vehicle in one of these, drive it out and close the door as soon as possible. If you drive it into one of these, turn it off as soon as possible.
- Do not run engine outdoors where engine exhaust can be drawn into a building through openings such as windows and doors.



# SAFETY LABELS AND LOCATIONS

## OVERVIEW

Warning labels have been placed on the vehicle for your protection. Read and follow the instructions of the labels on the vehicle carefully. If any of the labels depicted in this manual differ from the labels on your vehicle, always read and follow the instructions of the labels on the vehicle.

Never remove any labels from your vehicle. If a label becomes illegible or comes off, contact your POLARIS dealer for a replacement. Replacement safety labels are provided at no charge.

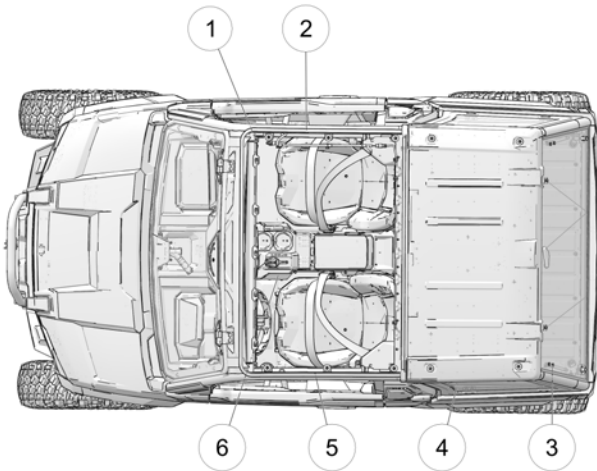

- ① Driver Information Warning
- ② Load/Passenger/Tire Pressure Warning
- ③ Fuel Transport Warning
- ④ Warning Label
- ⑤ Driver Information Warning
- ⑥ Driver Information Warning

## SAFETY

---

### FUEL TRANSPORT WARNING

The Fuel Transport Warning is located in the cargo box.

#### **WARNING**

NEVER carry fuel or other flammable liquids on this vehicle. Failure to follow this instruction could lead to serious burn injuries or death.

Part number: 7186122 (English), 7186122-F (French-Canadian)

### PROPER USE WARNING

The Proper Use Warning label is located on the ROPS.

#### **WARNING**

##### **Be Prepared**

- Fasten seat belts.
- Wear an approved helmet and protective gear.
- **ALWAYS** use vehicle cab nets and/or doors.
- Each rider must be able to sit whit back against seat, feet flat on the floor, and hands on steering wheel or handholds.
- Stay completely inside the vehicle.

#### **WARNING**

Improper vehicle use can result in SEVERE INJURY or DEATH

#### **WARNING**

##### **Drive Responsibly**

Avoid loss of control and rollovers:

- Avoid abrupt maneuvers, sideways sliding, skidding, or fishtailing, and never do donuts.
- Avoid hard acceleration when turning, even from a stop.
- Plan for hills, rough terrain, ruts, and other changes in traction and terrain. Avoid paved surfaces.
- Avoid side hilling (riding across slopes).

#### **WARNING**

Rollovers have caused severe injuries and death even on flat, open areas.

**⚠ WARNING****Be Sure Riders Pay Attention and Plan Ahead**

- If you think or feel the vehicle may tip or roll, reduce your risk to injury:
- Keep a firm grip on the steering wheel or handholds and brace yourself.
- Do not put any part of your body outside of the vehicle for any reason.

**⚠ WARNING****Require Proper Use of Your Vehicle**

Do your part to prevent injuries:

- Do not allow careless or reckless driving.
- Make sure operators are 16 or older with a valid driver's license.
- Do not let people drive or ride after using alcohol or drugs.
- Do not allow operation on public roads (unless designated for off-highway vehicle access) — collisions with cars and trucks can occur.
- Do not exceed seating capacity: 2 occupants.

Part Number: 7300596 (English), 7300596–F (French Canadian)

**MAXIMUM PAYLOAD/ TIRE PRESSURE WARNING**

The Maximum Payload/ Tire Pressure Warning label is located in the cargo box area.

**⚠ WARNING**

- Never carry passengers in cargo area during operation.
- If total payload is greater than 500 lbs, the vehicle must be operated in LOW range.

**⚠ WARNING**

**IMPROPER TIRE PRESSURE OR OVERLOADING CAN CAUSE LOSS OF CONTROL RESULTING IN SERIOUS INJURY OR DEATH.**

- Reduce speed and allow greater distance for braking when carrying cargo.
- Overloading or carrying tall, off-center, or unsecured loads will increase your risk of losing control. Loads should be centered and carried as low as possible in box.
- For stability on rough or hilly terrain, reduce speed and cargo.

# SAFETY

<b>POLARIS XPEDITION XP POLARIS XPEDITION ADV</b>	<b>PREMIUM</b>	<b>ULTIMATE</b>	<b>NORTHSTAR</b>
MAXIMUM CARGO BOX LOAD	600 lbs	600 lbs	600 lbs
TIRE PRESSURE IN PSI (KPa)	Front: 14 PSI (97 kPa) Rear: 18 PSI (124 kPa)	Front: 14 PSI (97 kPa) Rear: 18 PSI (124 kPa)	Front: 16 PSI (110 kPa) Rear: 22 PSI (152 kPa)
MAXIMUM WEIGHT CAPACITY INCLUDES WEIGHT OF OPERATOR, PASSENGER, CARGO, AND ACCESSORIES.	1030 lbs (467 kg)	1030 lbs (467 kg)	1030 lbs (467 kg)

## Additional Payload Information

Never Exceed	43 mph (69 kph)	43 mph (69 kph)	43 mph (69 kph)
If Total Payload Exceeds	430 lbs (195 kg)	430 lbs (195 kg)	430 lbs (195 kg)

POLARIS XPEDITION XP 5 POLARIS XPEDITION ADV 5	PREMIUM	ULTIMATE	NORTHSTAR
MAXIMUM CARGO BOX LOAD	600 lbs	600 lbs	600 lbs
TIRE PRESSURE IN PSI (kPa)	Front: 18 PSI (124 kPa) Rear: 22 PSI (152 kPa)	Front: 18 PSI (124 kPa) Rear: 22 PSI (152 kPa)	Front: 22 PSI (152 kPa) Rear: 26 PSI (179 kPa)
MAXIMUM WEIGHT CAPACITY INCLUDES WEIGHT OF OPERATOR, PASSENGER, CARGO, AND ACCESSORIES.	1160 lbs (526 kg)	1160 lbs (526 kg)	1160 lbs (526 kg)

### Additional Payload Information

Never Exceed	50 mph (80 kph)	50 mph (80 kph)	50 mph (80 kph)
If Total Payload Exceeds	645 lbs (293 kg)	645 lbs (293 kg)	645 lbs (293 kg)

Read Operation & Maintenance Manual for more detailed loading information.

Part number: 7300797 (English), 7300797–F (French Canadian)

## BELT WARNING

The Belt Warning label is located on the clutch cover.

### WARNING

Improper service or maintenance of this PVT system can result in vehicle damage, SEVERE INJURY or DEATH.

Always look for and remove debris inside and around clutch and vent system when replacing belt.

Read owner's manual or see authorized Polaris dealer.

Part number: 7177469 (English), 7177469–F (French Canadian)

## SAFETY

---

### AIR FILTER CAUTION

The Air Filter Caution label is located on the air filter housing.

#### CAUTION

Use a Polaris approved air filter. The use of a non-Polaris approved air filter may cause engine damage. Before installing filter, ensure there is no dirt or debris in the clean side of the intake tube. The air filter must be properly seated before the lid is reinstalled. Please reference your owner's manual for additional information regarding air filter service.

Part Number 7182652 (English), 7182652-F (French Canadian)

## TIP OUT WINDSHIELD WARNING (NORTHSTAR MODELS ONLY)

The Tip Out Windshield Warning is located on the windshield.

### **WARNING**

With windshield in vented or fully tipped position, do not drive on rough terrain, and do not exceed 45 mph (72 km/h). Keep windshield closed and latched in all other driving conditions. Failure to do so could cause the windshield system to fail resulting in serious injury or death.

Part number: 7300909 (English), 7300909-F (French Canadian)

## SAFETY LABELS AND LOCATIONS

### OVERVIEW, ADV 5 MODELS

Warning labels have been placed on the vehicle for your protection. Read and follow the instructions of the labels on the vehicle carefully. If any of the labels depicted in this manual differ from the labels on your vehicle, always read and follow the instructions of the labels on the vehicle.

Never remove any labels from your vehicle. If a label becomes illegible or comes off, contact your POLARIS dealer for a replacement. Replacement safety labels are provided at no charge.

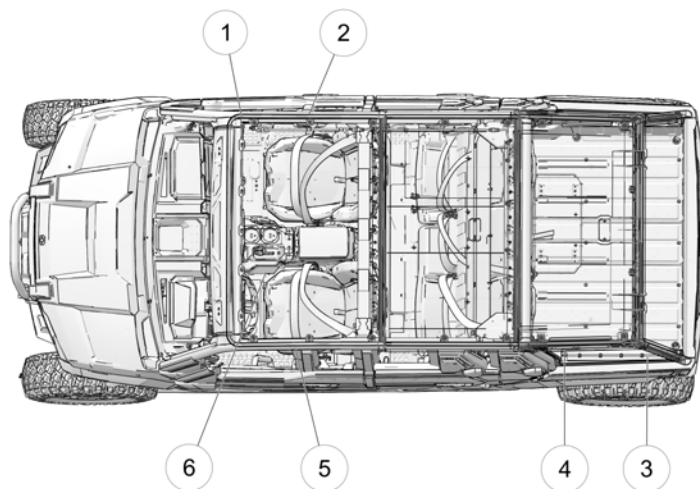

- ① Driver Information Warning
- ② Load/Passenger/Tire Pressure Warning
- ③ Fuel Transport Warning
- ④ Warning Label
- ⑤ Driver Information Warning
- ⑥ Driver Information Warning



---

## FUEL TRANSPORT WARNING

The Fuel Transport Warning is located in the cargo box.

### WARNING

NEVER carry fuel or other flammable liquids on this vehicle. Failure to follow this instruction could lead to serious burn injuries or death.

Part number: 7186122 (English), 7186122-F (French-Canadian)

## PROPER USE WARNING

The Proper Use Warning label is located on the ROPS.

### WARNING Be Prepared

- Fasten seat belts.
- Wear an approved helmet and protective gear.
- **ALWAYS** use vehicle cab nets and/or doors.
- Each rider must be able to sit whit back against seat, feet flat on the floor, and hands on steering wheel or handholds.
- Stay completely inside the vehicle.

The Proper Use Warning label is located on the ROPS.

### WARNING Be Prepared

- Fasten seat belts.
- Wear an approved helmet and protective gear.
- **ALWAYS** use vehicle cab nets and/or doors.
- Each rider must be able to sit whit back against seat, feet flat on the floor, and hands on steering wheel or handholds.
- Stay completely inside the vehicle.

### WARNING

Improper vehicle use can result in SEVERE INJURY or DEATH

# SAFETY

---

## **WARNING**

### **Drive Responsibly**

Avoid loss of control and rollovers:

- Avoid abrupt maneuvers, sideways sliding, skidding, or fishtailing, and never do donuts.
- Avoid hard acceleration when turning, even from a stop.
- Plan for hills, rough terrain, ruts, and other changes in traction and terrain. Avoid paved surfaces.
- Avoid side hilling (riding across slopes).

## **WARNING**

Rollovers have caused severe injuries and death even on flat, open areas.

## **WARNING**

### **Be Sure Riders Pay Attention and Plan Ahead**

- If you think or feel the vehicle may tip or roll, reduce your risk to injury:
- Keep a firm grip on the steering wheel or handholds and brace yourself.
- Do not put any part of your body outside of the vehicle for any reason.

## **WARNING**

### **Require Proper Use of Your Vehicle**

Do your part to prevent injuries:

- Do not allow careless or reckless driving.
- Make sure operators are 16 or older with a valid driver's license.
- Do not let people drive or ride after using alcohol or drugs.
- Do not allow operation on public roads (unless designated for off-highway vehicle access) — collisions with cars and trucks can occur.
- Do not exceed seating capacity: 5 occupants.

Part Number: 7300597 (English), 7300597–F (French Canadian)

## **MAXIMUM PAYLOAD/ TIRE PRESSURE WARNING**

The Maximum Payload/ Tire Pressure Warning label is located in the cargo box area.

## **WARNING**

- Never carry passengers in cargo area during operation.
- If total payload is greater than 500 lbs, the vehicle must be operated in LOW range.

**WARNING**

IMPROPER TIRE PRESSURE OR OVERLOADING CAN CAUSE LOSS OF CONTROL RESULTING IN SERIOUS INJURY OR DEATH.

- Reduce speed and allow greater distance for braking when carrying cargo.
- Overloading or carrying tall, off-center, or unsecured loads will increase your risk of losing control. Loads should be centered and carried as low as possible in box.
- For stability on rough or hilly terrain, reduce speed and cargo.

<b>POLARIS XPEDITION XP POLARIS XPEDITION ADV</b>	<b>PREMIUM</b>	<b>ULTIMATE</b>	<b>NORTHSTAR</b>
MAXIMUM CARGO BOX LOAD	600 lbs	600 lbs	600 lbs
TIRE PRESSURE IN PSI (KPa)	Front: 14 PSI (97 kPa) Rear: 18 PSI (124 kPa)	Front: 14 PSI (97 kPa) Rear: 18 PSI (124 kPa)	Front: 16 PSI (110 kPa) Rear: 22 PSI (152 kPa)
MAXIMUM WEIGHT CAPACITY INCLUDES WEIGHT OF OPERATOR, PASSENGER, CARGO, AND ACCESSORIES.	1030 lbs (467 kg)	1030 lbs (467 kg)	1030 lbs (467 kg)

**Additional Payload Information**

Never Exceed	43 mph (69 kph)	43 mph (69 kph)	43 mph (69 kph)
If Total Payload Exceeds	430 lbs (195 kg)	430 lbs (195 kg)	430 lbs (195 kg)

# SAFETY

<b>POLARIS XPEDITION XP 5 POLARIS XPEDITION ADV 5</b>	<b>PREMIUM</b>	<b>ULTIMATE</b>	<b>NORTHSTAR</b>
MAXIMUM CARGO BOX LOAD	600 lbs	600 lbs	600 lbs
TIRE PRESSURE IN PSI (KPa)	Front: 18 PSI (124 kPa) Rear: 22 PSI (152 kPa)	Front: 18 PSI (124 kPa) Rear: 22 PSI (152 kPa)	Front: 22 PSI (152 kPa) Rear: 26 PSI (179 kPa)
MAXIMUM WEIGHT CAPACITY INCLUDES WEIGHT OF OPERATOR, PASSENGER, CARGO, AND ACCESSORIES.	1160 lbs (526 kg)	1160 lbs (526 kg)	1160 lbs (526 kg)

## Additional Payload Information

Never Exceed	50 mph (80 kph)	50 mph (80 kph)	50 mph (80 kph)
If Total Payload Exceeds	645 lbs (293 kg)	645 lbs (293 kg)	645 lbs (293 kg)

Read Operation & Maintenance Manual for more detailed loading information.

Part number: 7300797 (English), 7300797–F (French Canadian)

## BELT WARNING

The Belt Warning label is located on the clutch cover.

### WARNING

Improper service or maintenance of this PVT system can result in vehicle damage, SEVERE INJURY or DEATH.

Always look for and remove debris inside and around clutch and vent system when replacing belt.

Read owner's manual or see authorized Polaris dealer.

Part number: 7177469 (English), 7177469–F (French Canadian)

## AIR FILTER CAUTION

The Air Filter Caution label is located on the air filter housing.

### CAUTION

Use a Polaris approved air filter. The use of a non-Polaris approved air filter may cause engine damage. Before installing filter, ensure there is no dirt or debris in the clean side of the intake tube. The air filter must be properly seated before the lid is reinstalled. Please reference your owner's manual for additional information regarding air filter service.

Part Number 7182652 (English), 7182652-F (French Canadian)

## TIP OUT WINDSHIELD WARNING (NORTHSTAR MODELS ONLY)

The Tip Out Windshield Warning is located on the windshield.

### WARNING

With windshield in vented or fully tipped position, do not drive on rough terrain, and do not exceed 45 mph (72 km/h). Keep windshield closed and latched in all other driving conditions. Failure to do so could cause the windshield system to fail resulting in serious injury or death.

Part number: 7300909 (English), 7300909-F (French Canadian)



## FEATURES AND CONTROLS

### NEAR-FIELD COMMUNICATION (NFC) (IF EQUIPPED)

Some Polaris vehicles come equipped with a near-field communication (NFC) chip. The NFC chip is embedded in the Polaris emblem located at the front of the vehicle and seamlessly connects you to a digital platform of vehicle information and tools. See your dealer for more information.

#### IMPORTANT

Not all devices are equipped with an NFC reader. Additionally, some devices require third party applications to access NFC content. For questions regarding the NFC reader on your device, refer to the device's user manual.

On models equipped with NFC, place your smartphone directly over the Polaris emblem to do the following:

- View vehicle specific information
- Access your Polaris Garage
- Download and view the owner's manual
- View accessory instructions
- Watch helpful videos
- Access warranty information
- Check for service notifications



### RIDE COMMAND WITH NFC

Additional NFC features are available when using the Ride Command mobile app. To access these features, do the following:

1. Download the Ride Command mobile app from the Apple App Store® or Google Play® store.
2. Create or log in to an existing account.
3. From the Ride Command mobile app home screen, select **Add Vehicle**.
4. On the vehicle, tap the NFC-enabled badge with the phone to scan the vehicle.
5. Confirm information, name your vehicle, and tap add to garage.

### SYSTEM REQUIREMENTS

Refer to device manufacturer's instructions to verify NFC read capability, and/or NFC-capable add-ons.

## FEATURES AND CONTROLS

---

### COMPONENT LOCATIONS, ADV MODELS

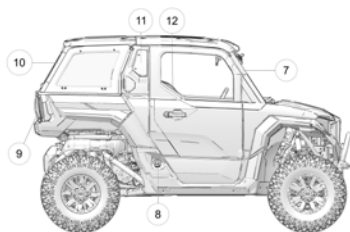

- ① Console
- ② Auxiliary Port
- ③ Front Bumper/ Brush Guard
- ④ Shock/ Spring
- ⑤ Radiator
- ⑥ Headlight

- ⑦ ROPS Cab Frame
- ⑧ Fuel Cap
- ⑨ Taillights
- ⑩ Rear Window
- ⑪ Fresh Air Inlet
- ⑫ Seat Belt

### COMPONENT LOCATIONS, ADV 5 MODELS

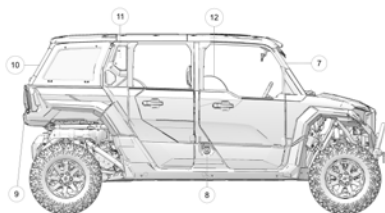

- ① Console
- ② Auxiliary Port
- ③ Front Bumper/ Brush Guard
- ④ Shock/ Spring
- ⑤ Radiator
- ⑥ Headlight

- ⑦ ROPS Cab Frame
- ⑧ Fuel Cap
- ⑨ Taillights
- ⑩ Rear Window
- ⑪ Fresh Air Inlet
- ⑫ Seat Belt



### **ADJUSTABLE STEERING WHEEL**

#### **STANDARD STEERING WHEEL (IF EQUIPPED)**

On models equipped with a standard steering wheel, the steering wheel can be tilted upward or downward for rider preference. Lift and hold the steering wheel adjustment lever while moving the steering wheel upward or downward. Release the lever when the steering wheel is at the desired position.

#### **TELESCOPIC STEERING WHEEL (IF EQUIPPED)**

On models equipped with a telescopic steering wheel, the steering wheel can be adjusted by pressing the release lever downward.

Once released, the steering wheel can be tilted up/down and telescoped in/out freely. When desired position is found, hold the steering wheel in place with one hand and pull the release lever back up with the other. The release lever will catch into place when it is locked.

## FEATURES AND CONTROLS

---

### GEAR SELECTOR

Low gear is the primary driving range for your vehicle. High gear is intended for use on hard-packed surfaces with light loads. Using high gear for heavy loads, hilly terrain or in wet, muddy conditions will increase the chance of drive belt burning. See the Drive Belt Wear/Burn section on Drive Belt Wear/Burn.

To shift gears, brake to a complete stop. When the engine is idling, move the lever ① to the desired gear.

P: Park  
R: Reverse  
N: Neutral  
L: Low Gear  
H: High Gear

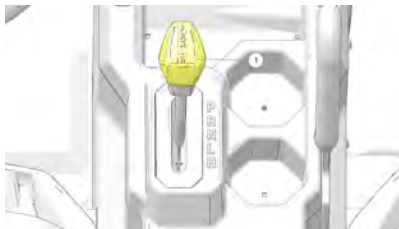

#### NOTICE

Shifting gears with the engine speed above idle or while the vehicle is moving could cause transmission damage. Always shift when the vehicle is stationary and the engine is at idle.

#### TIP

Maintaining shift linkage adjustment is important to assure proper transmission function. Your POLARIS dealer, or other qualified person, can assist in resolving any shifting problems.

### USING LOW RANGE

Always shift into low gear for any of the following conditions.

- Operating in rough terrain or over obstacles
- Loading the vehicle onto a trailer
- Towing loads
- Driving frequently at low RPM or at ground speeds below 7 MPH (11 km/h)

## SWITCHES

### IGNITION SWITCH

OFF	The engine is off. Electrical circuits are off. No 12V power to any accessory power ports.
ACCESSORY (if equipped)	The engine is off. Powers the power windows, display, audio, interior lights, pulse bar, USB, and 12V sockets. The instrument cluster will not be powered.
ON	Electrical circuits are on. Electrical equipment can be used.
START	Turn the key to the START position to engage the electric starter. The key returns to the ON position when released.

The ignition switch ① is a four-position, key-operated switch. The key can be removed from the switch when it is in the OFF position.

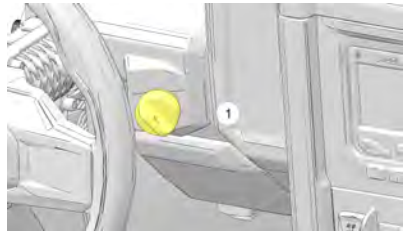

### AWD/DIFFERENTIAL LOCK SWITCH

The AWD switch has three positions:

- All Wheel Drive (AWD)
- Two Wheel Drive (2WD)
- Differential Unlock (TURF mode)



## FEATURES AND CONTROLS

### POLARIS 3-MODE THROTTLE CONTROL SWITCH

The Polaris 3-Mode Throttle Control Switch has three positions:

- Comfort (COMF)
- Standard (STND)
- Sport (SPRT)

MODE	DESCRIPTION
Comfort (COMF)	Allows minimized engine feedback when pressing the throttle pedal.
Standard (STND)	Allows slight less than MAX engine feedback when pressing the throttle pedal.
Sport (SPRT)	Allows MAX engine feedback when pressing the throttle pedal.



Always use low gear for any of the following conditions regardless of the selected throttle control setting:

- Operating in rough terrain or over obstacles.
- Loading the vehicle onto a trailer.
- Towing heavy loads.
- Driving frequently at low RPM or at ground speeds below 7 MPH (11 km/h).

### LIGHT SWITCH

The ignition switch key must be in the ON/RUN position to operate the headlights. Press the top of the switch to place the headlights on high beam. Move the switch to the center position to place the headlights on low beam. Press the bottom of the switch to turn off the headlights.



### WINCH SWITCH (IF EQUIPPED)

Press the top of the rocker switch to spool line out from the winch. Press the bottom of the rocker switch to spool line in to the winch. Move the rocker switch to the center position to stop spooling.



### **SWITCHES - NORTHSTAR** **HVAC CONTROL PANEL (IF EQUIPPED)**

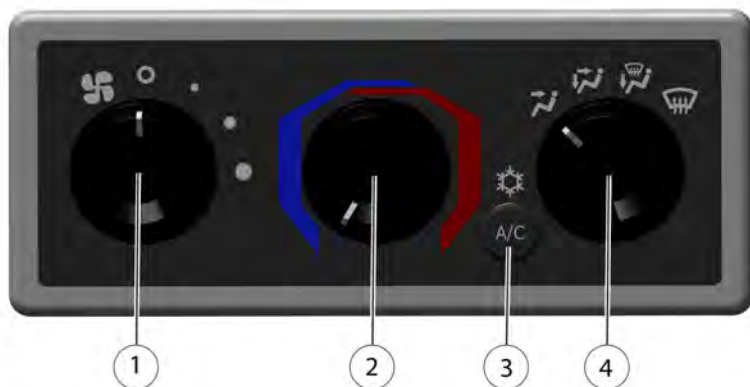

To operate the cab heater, rotate the fan control ① to the desired fan speed setting. The far left setting turns the fan off.

Adjust the temperature by rotating the temperature control ② to the desired heat setting. Rotate the control clockwise to increase heat or counter-clockwise to decrease heat.

Press the A/C switch ③ to enable the air conditioning system for cooling or defrost purposes.

Rotate the position switch ④ to select the air delivery mode. These modes let you direct airflow where needed (Vent, Vent / Lower Vent, Lower Vent / Defrost, Defrost).

When the defrost mode is selected, the A/C is automatically engaged to help clear the windshield. The A/C switch ③ can be used to manually disable the A/C.

### **WINDSHIELD WIPER/WASHER SWITCH** **(IF EQUIPPED)**

The windshield wiper/washer switch is located on the vehicle dashboard. The windshield washer fluid reservoir is located under the hood.

Select the desired function by pressing the top or bottom of the switch. The windshield wiper/washer switch has three positions:

- WASHER ON - top of switch fully pressed
- WIPER ON - middle position
- OFF - bottom of switch fully pressed



### WINDOW SWITCHES (IF EQUIPPED)

Electric window switches (if equipped) can be found in the center console.



### AUXILIARY OUTLET

The vehicle is equipped with 12-volt accessory outlet in the center console storage bin. An additional outlet is located on the rear side of the center console on Crew models. Use the outlets to power an auxiliary light or other optional accessories or lights.



## FEATURES AND CONTROLS

---

### USB OUTLET

The vehicle is equipped with a dual USB outlet in the center console. The outlet consists of two USB terminals.



### BATTERY TRICKLE-CHARGING OUTLET

The vehicle is equipped with a dedicated outlet for trickle-charging the battery during periods of extended inactivity.

If you do not drive the vehicle for more than TWO WEEKS, Polaris recommends using a BatteryMINDER® 2012 AGM - 2 AMP charger (PN 2830438), which can be ordered through your dealer.

Polaris provides a charging accessory with your vehicle that allows easy connection to the battery through the Battery Trickle-Charging Outlet, located on the front of the vehicle. While charging, place the charger outside of the vehicle and protect it from moisture.





## FOOT PEDALS

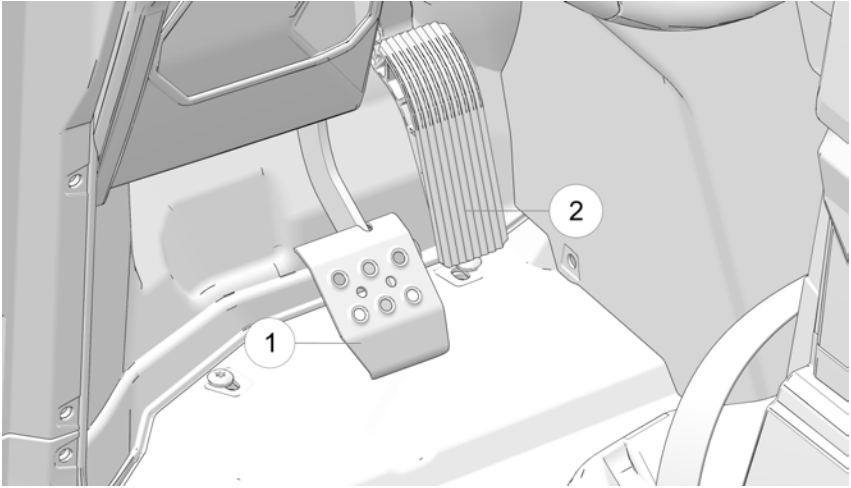

### BRAKE PEDAL

Depress the brake pedal ① to slow or stop the vehicle. Apply the brakes while starting the engine.

When the brake pedal is depressed, the brake light comes on. Check the brake light before each ride.

1. Turn the ignition switch to the ON position.
2. Apply the brakes. The brake light should come on after about 10 mm (0.4 in.) of pedal travel.

### THROTTLE PEDAL

Push the throttle pedal ② down to increase engine speed. Spring pressure returns the pedal to the rest position when released. Always check that the throttle pedal returns normally before starting the engine.

#### TIP

If the throttle pedal and brake pedal are applied simultaneously, engine power may be limited.

### SEATS

#### SEAT BELTS

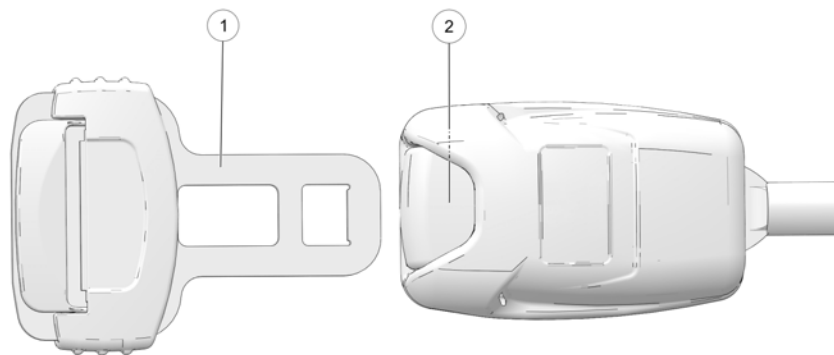

This vehicle is equipped with three-point lap and diagonal seat belts for the operator and any passengers. Always make sure the seat belts are secured for all riders before operating. The driver's seat belt is equipped with a seat belt interlock. Vehicle speed will be limited to 15 MPH (24 km/h) if the seat belt is not secured.

#### WARNING

Falling from a moving vehicle could result in serious injury or death. Always fasten your seat belt securely before operating or riding in the vehicle.

To wear the seat belt properly, follow this procedure:

1. For 3-point belts, pull the seat belt latch ① downward and across your chest toward the buckle at the inner edge of the seat. The belt should fit snugly across your hips and diagonally across your chest. Make sure the belt is not twisted.
2. Push the latch plate ① into the buckle ② until it clicks.
3. Release the strap, it will self tighten.
4. To release the seat belt, press the square red button in the buckle's center.

### SEAT BELT INSPECTION

#### WARNING

Failure to perform regular inspection can reduce the effectiveness of the seat belt during a crash and could result in serious injury or death.

Inspect all seat belts for proper operation before each use of the vehicle.

1. Push the latch plate into the buckle until it clicks. The latch plate must slide smoothly into the buckle. A click indicates that it's securely latched.
2. Push the red release latch in the middle of the buckle to make sure it releases freely.
3. Pull each seat belt completely out and inspect the full length for any damage, including cuts, wear, fraying or stiffness. If any damage is found, or if the seat belt does not operate properly, have the seat belt system checked and/or replaced by an authorized dealer.
4. To clean dirt or debris from the seat belts, sponge the straps with mild soap and water. Do not use bleach, dye or household detergents. Rinse the entire length of the belt webbing. Use a garden hose to flush out the retractor and latch housings regularly.

### STORAGE COMPARTMENTS

A small storage compartment is located between the driver's seat and passenger's seat<sup>①</sup>. Lift the console lid to access the storage compartment.

The electrical compartment is located under the driver's seat. Never use the electrical compartment for storage. Remove the driver's seat to access the battery.

The fuse panel is located under the small storage compartment liner. The fuse panel can be accessed by lifting the liner of the center storage compartment out of the console.



### FRONT SEAT REMOVAL / INSTALLATION

#### **DRIVERS SEAT (2 PASSENGER MODELS)/ FRONT PASSENGER SEAT (5 PASSENGER MODELS), REMOVAL**

1. Remove the two seat mount bracket fasteners.

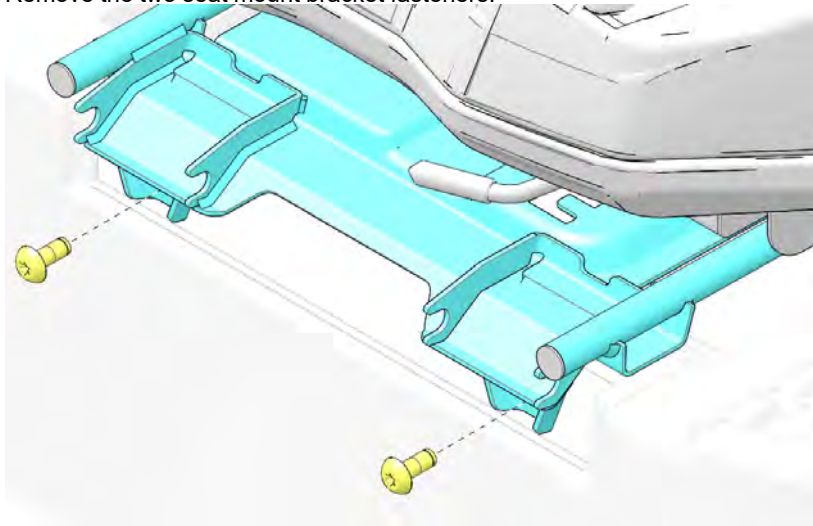

#### NOTICE

A T40 Torx can be found in the tool kit provided with your vehicle to remove these fasteners.

2. Pull up on the seat slider release lever, and slide the seat to the forward most position.
3. Slide the complete seat assembly forward and then remove the seat assembly from the vehicle.

#### **DRIVERS SEAT (2 PASSENGER MODELS)/ FRONT PASSENGER SEAT (5 PASSENGER MODELS), INSTALLATION**

1. Before placing the seat into the vehicle, slide the seat to the forward most position on the seat sliders..
2. Install the seat assembly in the vehicle.
3. Pull up on the seat slider release lever, and slide the seat to the rearward most position.

4. Align the mount points and make sure the seat base is attached to the seat mount.

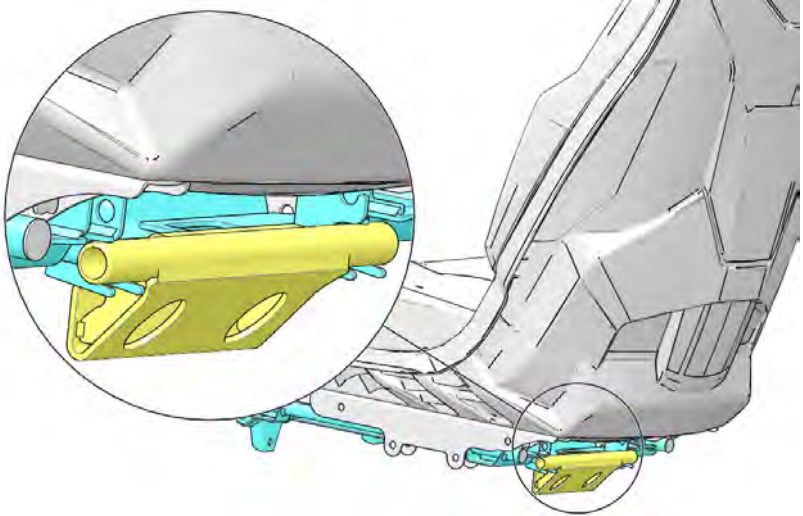

5. Install the seat base mounting fasteners. Torque to specification.

### TORQUE

Seat Base Mounting Fastener:  
13 ft lbs (18 Nm)

## FEATURES AND CONTROLS

---

### **PASSENGER SEAT (2 PASSENGER MODELS), REMOVAL**

1. Remove the two seat base mounting fasteners from the front of the seat.

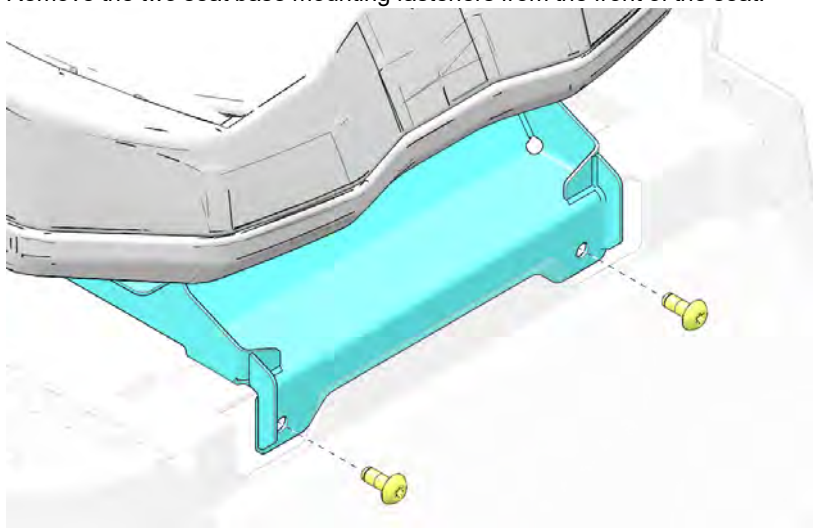

#### *NOTICE*

A T40 Torx can be found in the tool kit provided with your vehicle to remove these fasteners.

2. Pull the seat forward and remove the seat from the vehicle.

### **PASSENGER SEAT (2 PASSENGER MODELS), INSTALLATION**

1. Install the seat assembly in the vehicle.
2. Align the mount points and make sure the seat base is attached to the seat mount.

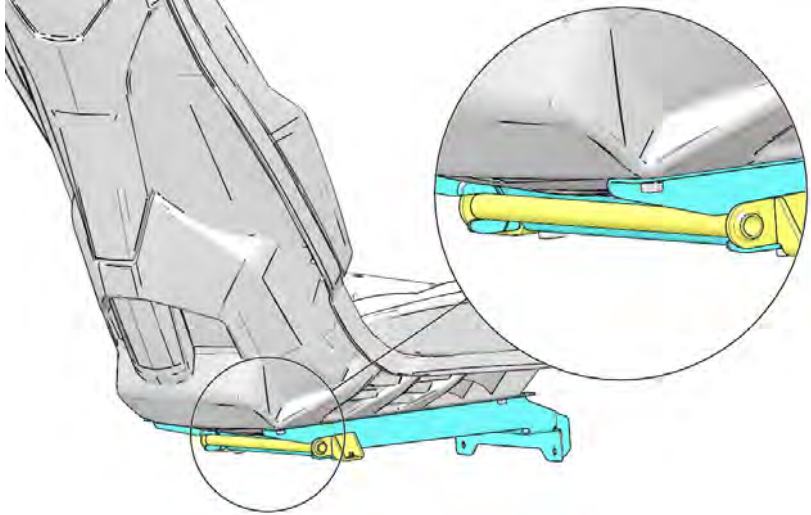

3. Install the seat base mounting fasteners. Torque to specification.

#### **TORQUE**

Seat Base Mounting Fastener:  
13 ft lbs (18 Nm)

### **REAR FOLDING SEAT**

The rear seat can be folded into several different configurations. The seat bottom can be folded up to create more room on the floor. The seat back can also be folded down to create more room from the cargo box area.

## FEATURES AND CONTROLS

---

### ***REAR SEAT BOTTOM FOLDING***

1. Lift up on the front edge of the rear seat bottom to fold up. Each section can be folded individually.

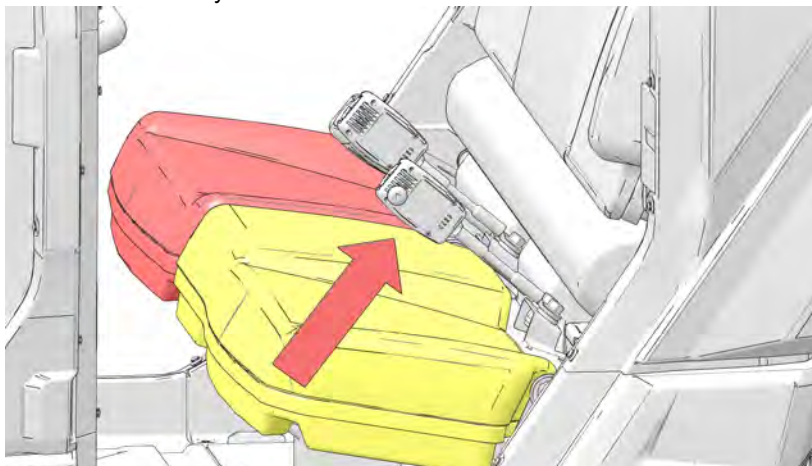



### REAR SEAT BACK

1. Secure the outer seatbelts to the inside of the seatbelt holder ①.

#### TIP

Routing the seatbelts behind the seatbelt holder ensures the belts are not over the seat while folding.

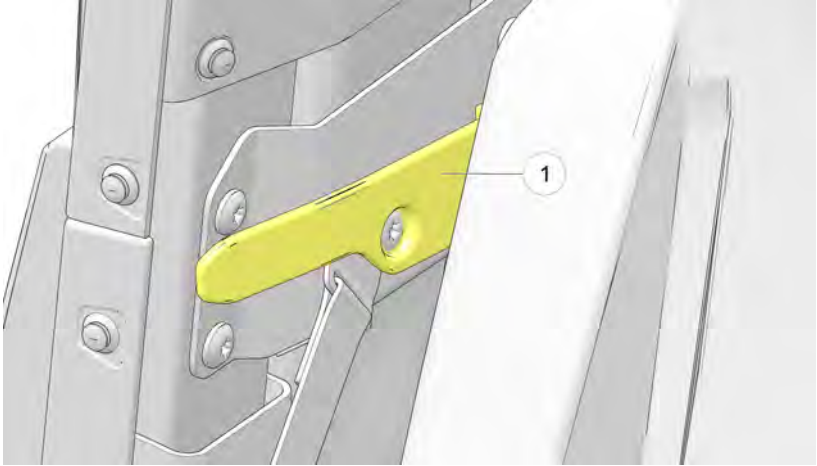

2. Pull firmly on the red release tether ② located in the middle rear of the rear seatback.

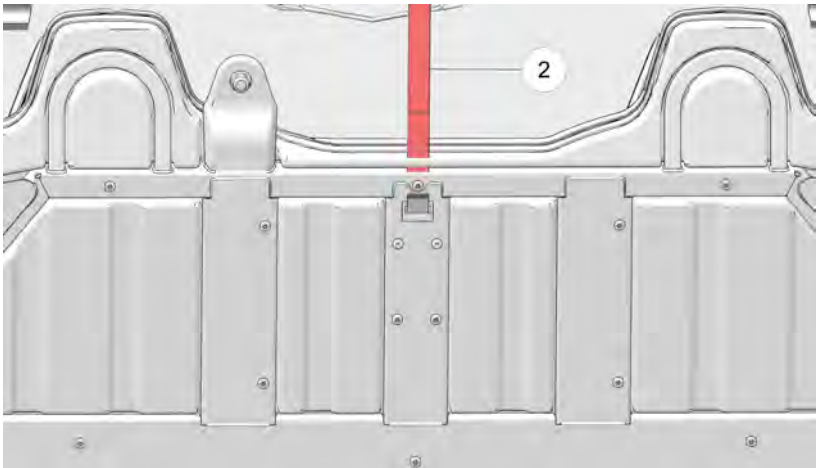

3. Fold the seatback forward.

## FEATURES AND CONTROLS

### NOTICE

Rear seatback must be up and latched while the rear seat is in use.

## ELECTRONIC POWER STEERING

Electronic power steering (EPS) engages when the ignition key is turned to the ON position. EPS remains engaged whether the vehicle is moving or idle. To conserve battery power, the EPS will shut down 5 minutes after the engine is stopped if the key remains in the ON position. The EPS warning indicator will illuminate to indicate the EPS has shut down. Turn the key off and on to reset the unit. If the light remains on after starting the engine, the EPS system is inoperative. See your POLARIS dealer, or other qualified person, as soon as possible for repair. Continued operation could result in permanent damage to the EPS unit and increased steering effort.

## ROLLOVER PROTECTIVE STRUCTURE (ROPS)

On 2P models, the ROPS decal is located on the rear roof crossbar, behind the drivers seat. On 5P models, the ROPS decal is located on the rear roof crossbar, behind the drivers side passenger seat.

Always have your authorized dealer thoroughly inspect the ROPS if it ever becomes damaged in any way. *No device can assure occupant protection in the event of a rollover.* Always follow all safe operating practices outlined in this manual to avoid vehicle rollover.

### WARNING

Vehicle rollover could cause severe injury or death. Always avoid operating in a manner that could result in vehicle rollover.

## TRAILER HITCH BRACKET

This vehicle is equipped with a receiver hitch bracket for a trailer hitch. A hitch capacity label is located on the hitch.

To avoid injury and property damage, always heed the warnings and towing capacities outlined on page 91.

## CAB DOORS

This vehicle is equipped with cab doors. Riding in this vehicle without closed and latched cab doors increases the risk of serious injury or death in the event of an accident or rollover. Always make sure all cab doors are closed and latched when riding in this vehicle.

Always inspect doors and latches for wear and damage before each use of the vehicle. Promptly replace any worn or damaged parts with new parts available from your authorized POLARIS dealer, or other qualified person.

### SIDE STEPS

This vehicle is equipped with side steps ① to help with vehicle loading of passengers and equipment. The front and the rear (if equipped) side steps have a maximum loading capacity of 300 lb (136 kg).

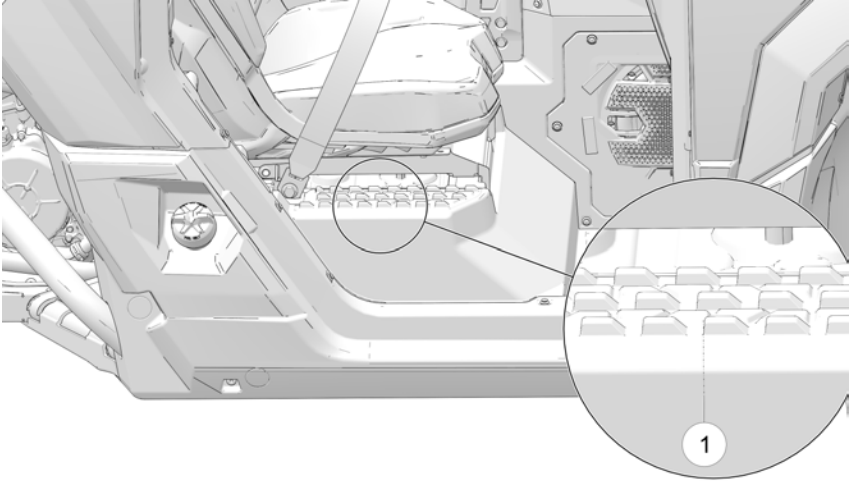

### FUEL CAP

The fuel tank filler cap ① is located on the right side of the vehicle near the passenger seat.



See page 86 for information on fuel types, quality, and seasonality.

## FEATURES AND CONTROLS

---

### HOOD

To remove the hood, do the following:

1. Turn the grille fasteners ① 1/4 turn.

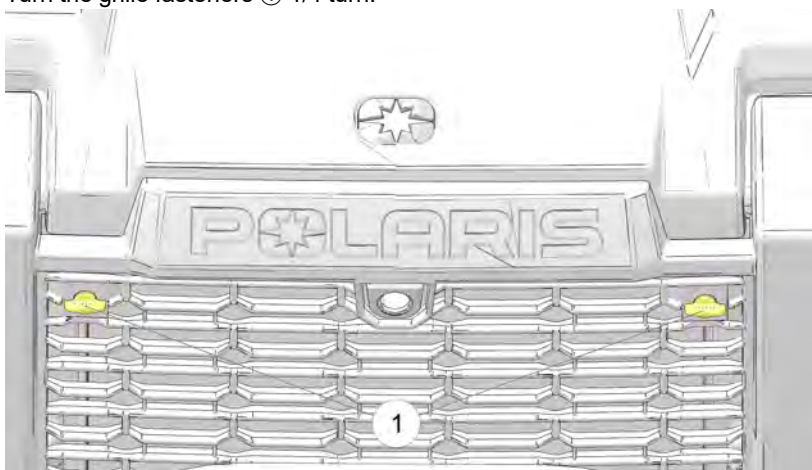

2. Pull the front grille up and away from the hood. Set the grille aside
3. Release the two rubber straps securing the hood to the vehicle.
4. Grasp the front hood edge and pull upward.
5. Pivot the hood ② forward and lift upward to disengage the lower hood hooks.

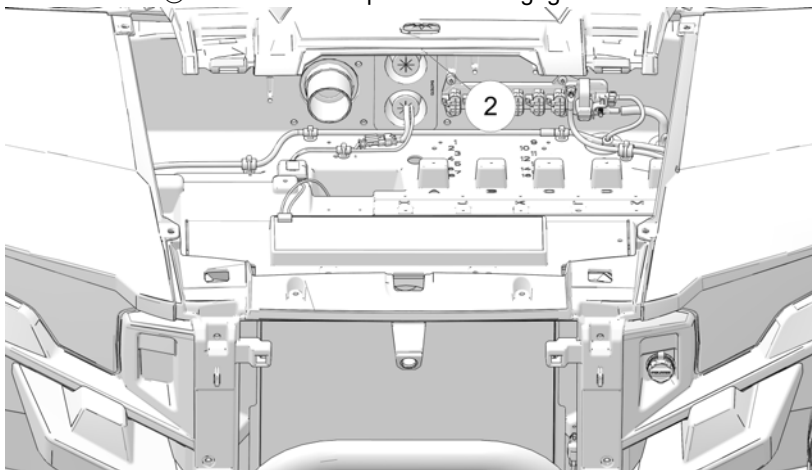

6. Lift the hood away from the vehicle.

## WATER FORDING LEVEL

Operating through deep or fast-flowing water can cause loss of traction, loss of control, overturning, or being swept away in water. You can be seriously injured or killed from entrapment and drowning. Never operate the vehicle in fast-flowing water or in water that exceeds the specification below. Avoid sharp drop-offs and large rocks. Choose a path that provides an entrance and exit point with gradual inclines. Wet brakes may have reduced stopping ability. After leaving water, test the brakes. Apply them lightly several times while driving slowly. The friction will help dry out the pads.

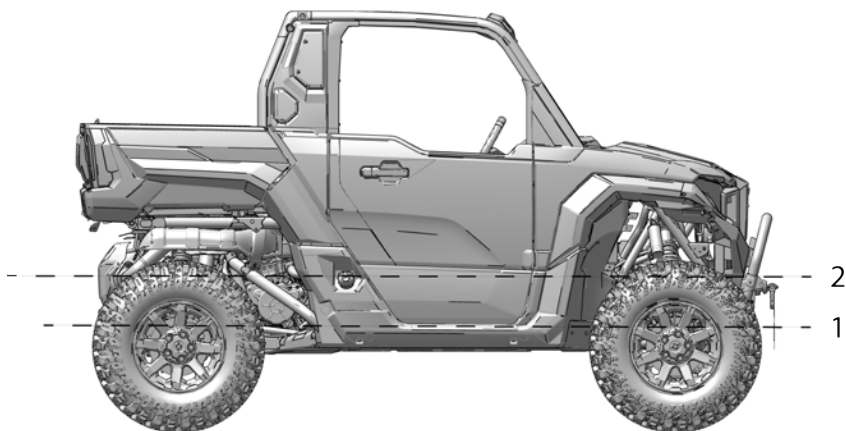

FIG- URE	MODEL	WATER FORDING HEIGHT
1	POLARIS XPEDITION ADV NorthStar	17.8 in (45.2 cm)
2	POLARIS XPEDITION ADV Premium/ Ultimate	28 in (71.5 cm)

## INSTRUMENT CLUSTER

### NOTICE

High water pressure may damage components. Wash the vehicle by hand or with a garden hose using mild soap. Certain products, including insect repellents and chemicals, will damage the speedometer lens and other plastic surfaces. Do not use alcohol to clean the instrument cluster. Do not allow insect sprays to contact the lens. Immediately clean off any gasoline that splashes on the instrument cluster.

## FEATURES AND CONTROLS

---



- ① Speedometer
- ② Tachometer
- ③ Indicator Lamps
- ④ Mode Button
- ⑤ Toggle Buttons
- ⑥ Rider Information Center

### **SPEEDOMETER**

The speedometer displays vehicle speed in either miles per hour (MPH) or kilometers per hour (km/h).

### **TACHOMETER**

The tachometer displays engine speed in revolutions per minute (RPM).

### **MODE BUTTON**

Press and hold the MODE button ④ to enter or exit the settings menu. Press and release the MODE button to cycle through Area 1 modes and to select an item.

### **TOGGLE BUTTONS**









Press and release either toggle button ⑤ to cycle through the options menu or Area 2 modes. Press and hold either toggle button to reset an item. See page 65.

#### **TIP**

With the ignition key off, pressing the MODE button or either toggle button will power up the Rider Information Center for 10 seconds to allow viewing of the odometer and the clock.

## FEATURES AND CONTROLS

### INDICATOR LAMPS

LAMP	INDICATES	CONDITION
<b>MPH</b>	Vehicle Speed	When standard mode is selected, speed displays in miles per hour.
<b>km/h</b>		When metric mode is selected, speed displays in kilometers per hour.
	Over Temperature	This lamp illuminates to indicate an overheated engine. If the indicator flashes, the overheating condition remains, and the system will automatically reduce engine power.
	Electric Power Steering (EPS) Warning (if equipped)	This indicator illuminates briefly when the key is turned to the ON position. If the light remains on, the EPS system is inoperative. See your POLARIS dealer, or other qualified person, as soon as possible for repair. Continued operation could result in permanent damage to the EPS unit and increased steering effort.
	High Beam	This lamp illuminates when the headlamp switch is set to high beam.
	Helmet/Seat Belt	This lamp is a reminder to the operator to ensure all riders are wearing helmets and seat belts before operating. The driver's seat belt is equipped with a seat belt interlock. Vehicle speed will be limited to 15 MPH (24 km/h) if the seat belt is not secured.
	Check Engine	This indicator appears if an Electronic Fuel Injection (EFI) related fault occurs. Do not operate the vehicle if this warning appears. Serious engine damage could result. Your authorized dealer or qualified person can assist.
	Check Battery	This warning usually indicates that the vehicle is operating at an RPM too low to keep the battery charged. It may also occur when the engine is at idle and high electrical load (lights, cooling fan, accessories) is applied. Drive at a higher RPM or recharge the battery to clear the warning.
	Low Fuel	This lamp illuminates when fuel level in the fuel tank is low.
	Speed Key (optional accessory)	Information about the speed key is provided in the accessory kit.
	Chassis Warning	If a fault condition is detected, the light will remain on as long as the condition exists. Retrieve the error codes for diagnosis. This lamp is also known as an Amber Warning Lamp (AWL).



## RIDER INFORMATION CENTER

①	AWD Indicator	This indicator shows whether 2X4 or AWD is active.
②	Fuel Gauge	The segments of the fuel gauge show the level of fuel in the fuel tank. When the last segment clears, a low fuel warning is activated. The outline of the fuel display will flash. Refuel immediately.
③	Service Indicator	A flashing wrench symbol alerts the operator that the preset service interval has been reached. Your POLARIS dealer, or other qualified person, can provide scheduled maintenance. See page 68 for resetting instructions.
④	Gear Indicator	This indicator displays gear shifter position. H = High Gear L = Low Gear N = Neutral R = Reverse Gear P = Park – = Gear Signal Error (or shifter between gears)
⑤	Speed Limitation (if equipped)	This vehicle may be equipped with a maximum speed limitation function. This would be displayed on the screen as “LIM” followed by the speed. “LIM 30” for example.

The rider information center is located in the instrument cluster. All segments will light up for one second at start-up. If the instrument cluster fails to illuminate, a battery over-voltage may have occurred and the instrument cluster may have shut off to protect the electronic speedometer. If this occurs, your POLARIS dealer, or other qualified person, can provide proper diagnosis.

The information center is set to display standard units of measurement and a 12-hour clock at the factory. To change to metric and/or a 24-hour clock hold the mode button and cycle to the clock menu. Use the directional arrows to change the clock settings.

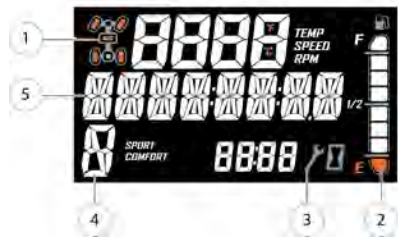

## FEATURES AND CONTROLS

### MODE INFORMATION DISPLAYS

The rider information center contains three areas that display mode information.



① Area 1 Modes	Description
Engine Temperature	Temperature of engine coolant
Vehicle Speed	Speed of vehicle
Tachometer	Engine speed (RPM)
② Area 2 Modes	Description
Odometer	The odometer records and displays the distance traveled by the vehicle.
Trip Meters (T1/T2)	A trip meter records the distance traveled by the vehicle if reset before each trip. To reset, see page 67.
Engine Hours	Total hours of engine operation since manufacture
Service Hours	A flashing wrench symbol indicates that the preset service interval has been reached. To reset, see page 68.
Trip Time	Time length of vehicle operation since mode was last reset
③ Area 3 Modes	Description
Clock	The clock displays time in a 12-hour or 24-hour format. To reset, see page 66.

### ACCESSING MENUS AND OPTIONS

#### **GAUGE SETTINGS MENU**

Press and release the MODE button to cycle through the Area 1 modes until the desired default mode displays. See the Mode Information Displays section for details.

Press and hold the MODE button to enter the settings menu.

*The OPTIONS screen will display for a few seconds.*

1. Press and release either toggle button to cycle to the desired option.
2. Press MODE to select the option.
3. Press either toggle button to cycle to the desired setting.
4. Press MODE to save and exit to the settings menu.
5. Press and hold the MODE button to exit the settings menu.



## FEATURES AND CONTROLS

---

### **BACKLIGHT BRIGHTNESS**

The information center backlight can be set to either blue or red.

1. Press and hold the MODE button to enter the settings menu.
2. Press either toggle button to cycle to the "BL LEVEL" option. Press MODE to select.
3. Press "UP" button to increase brightness. Press "DOWN" button to decrease brightness.
4. Press MODE to select and exit to the settings menu.



### **CLOCK**

The clock must be reset any time the battery has been disconnected or discharged.

1. Press and hold the MODE button to enter the settings menu.
2. Press either toggle button to cycle to the "CLOCK" option. Press MODE to select.
3. Press either toggle button to cycle to the desired setting (12H or 24H). Press MODE to select.
4. Press either toggle button to change each segment of the clock. Press MODE to accept a change and advance to the next segment.

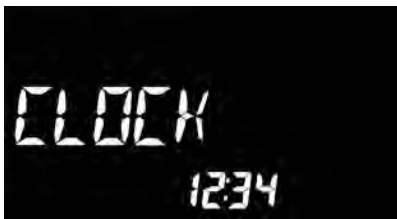

### **DISPLAY UNITS (STANDARD/METRIC)**



1. Press and hold the MODE button to enter the settings menu.
2. Press either toggle button to cycle to the desired "UNITS" option (distance, temperature or volume). Press MODE to select.
3. Press either toggle button to cycle to the desired setting.
4. Press MODE to save and exit to the settings menu.

### ***TRIP METER***

Use a trip meter to track the distance traveled during a specific trip or period of time. Reset the meter to zero before traveling.

1. Press either toggle button to cycle to the desired trip meter option (T1 or T2).
2. Press and hold either toggle button until the meter resets to zero.

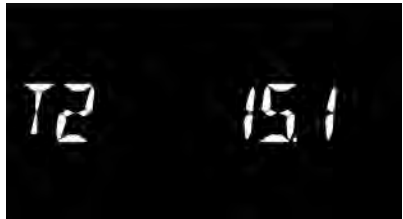

## FEATURES AND CONTROLS

---

### **TRIP TIME**

Use a trip time meter to track the travel time during a specific trip. Reset the meter to zero before traveling.

1. Press either toggle button to cycle to the trip time option (TT).
2. Press and hold either toggle button until the meter resets to zero.



### **PROGRAMMABLE SERVICE INTERVAL**

The service interval counter is programmed to 25 hours at the factory. As hours of engine operation increase, the counter decreases. The wrench icon will flash for about 10 seconds when the counter reaches zero (0), and each time the key is turned on thereafter, until the counter is reset.

When this feature is enabled, it provides a convenient reminder to perform routine maintenance. Refer to the Polaris Maintenance Schedule for recommended service intervals.

Use the following procedure to reset or change the service interval.

1. Press and hold the MODE button to enter the settings menu.
2. Press either toggle button to cycle to the "Service Hours" option. Press MODE to select.
3. Press MODE to reset the existing value and exit, or press either toggle button to change the value. Press MODE to save and exit to the settings menu.



### ENGINE ERROR CODES

The error screen displays only when the CHECK ENGINE indicator is on or when it goes on and off during one ignition cycle. Error codes are not stored. When the key is turned OFF, the code and message is lost, but will reappear if the fault reoccurs after restarting the engine.

If the CHECK ENGINE lamp or the EPS lamp illuminates, retrieve the active error codes from the display.

- ① Failure Mode Indicator (FMI)
- ② Suspect Parameter Number (SPN)
- ③ Code Count



1. Press and hold the MODE button to enter the settings menu.
2. Press either toggle button to cycle to the “DIAGCODE” option. Press MODE to select.
3. More than one diagnostic code may be present. Press the toggle UP button to see if more codes are present. Press MODE to select a code.

#### NOTICE

If the displayed code is an engine fault code, the CHECK ENGINE lamp will blink. If the displayed code is an EPS fault code, the EPS lamp will blink.

4. Record the three (3) numbers displayed.
5. Press MODE to exit to the settings menu.





## RIDE COMMAND DISPLAY (IF EQUIPPED)

### BEFORE YOU RIDE

#### WARNING

Failure to pay attention to operating your vehicle could result in loss of control, injury, or death. Always concentrate on riding. Do not enter information while operating your vehicle. Some features are limited when vehicle is in motion.

Before riding with your new display, do the following:

- Download the Polaris RIDE COMMAND App from the Apple®/Google Play® store and create your personalized account.
- Check your display to ensure you have the appropriate maps and trails visible for your area. To change or update maps/trails see page 83.
- Trails change often, and the trail data file is only considered valid for 90 days after the release date. Please keep your trail data up to date. Download the latest trails at <http://ridecommand.polaris.com>.

#### NOTICE

Using the display for an extended period of time while the vehicle's engine is off can drain the battery.

## VEHICLE-TO-VEHICLE COMMUNICATION (V2V)

#### IMPORTANT

For applications that use vehicle-to-vehicle (V2V) communication, radio transmitter IC: 5966A-P001 has been approved by Innovation, Science and Economic Development Canada (ISED) to operate with the Polaris antenna (part number 4019300) with gain of 1dBi. Any antenna that has a gain greater than 3 dBi is prohibited for use with this device.

## DEVICE OPERATING REQUIREMENTS

Phone functionality is dependent on the capabilities of your cell phone.

#### NOTICE

Some cell phones or operating systems will not work as shown in this manual.

## RIDE COMMAND DISPLAY (IF EQUIPPED)

### RADIO COMPLIANCE STATEMENTS

#### USA RADIO COMPLIANCE

Some vehicles may contain the following radio equipment or components:

COMPONENT	COMPONENT ID	MANUFACTURER
9200 Series RC-7 Display	PN 4081663	Polaris Industries Inc.
JBL® AM/FM/WB Radio with Bluetooth®	PN 2415723	Harman Technology®
V2V Antenna	PN 4019300	Amphenol®

This device complies with part 15 of the FCC Rules. Operation is subject to the following two conditions: (1) This device may not cause harmful interference, and (2) this device must accept any interference received, including interference that may cause undesired operation.

#### CAUTION

Changes or modifications not expressly approved by the party responsible for compliance could void the user's authority to operate the equipment.

#### CANADA RADIO COMPLIANCE

Some vehicles may contain the following radio equipment or components:

COMPONENT	COMPONENT ID	MANUFACTURER
9200 Series RC-7 Display	PN 4081663	Polaris Industries Inc.
JBL® AM/FM/WB Radio with Bluetooth®	PN 2415723	Harman Technology®
V2V Antenna	PN 4019300	Amphenol®

This device contains license-exempt transmitter(s)/receiver(s) that comply with Innovation, Science and Economic Development Canada's license-exempt RSS (s). Operation is subject to the following two conditions:

## RIDE COMMAND DISPLAY (IF EQUIPPED)

1. This device may not cause interference.
2. This device must accept any interference, including interference that may cause undesired operation of the device.

### IMPORTANT

For applications that use vehicle-to-vehicle (V2V) communication, radio transmitter IC 5966A-P001 has been approved by Innovation, Science and Economic Development Canada (ISED) to operate with Polaris antenna (part number 4019300) with gain of 1dBi. Any antenna that has a gain greater than 3 dBi is prohibited for use with this device.

## EUROPEAN UNION (EU) RADIO COMPLIANCE

Some vehicles may contain the following radio equipment or components:

<b>Component</b>	9200 Series RC-7 Display
<b>Component ID</b>	PN 4081663
<b>Manufacturer</b>	Polaris Industries Inc.
<b>*Transmitting Frequency</b>	2402 - 2480 MHz
<b>Max RF Transmitting PWR</b>	0.2432 W
*Other transmitting radio frequencies may exist outside of EU markets.	

<b>Component</b>	JBL AM/FM/WB Radio with Bluetooth®
<b>Component ID</b>	PN 2415723
<b>Manufacturer</b>	Harman Technology®
<b>*Transmitting Frequency</b>	2402 – 2483.5 MHz
<b>Max RF Transmitting PWR</b>	0.00107W
*Other transmitting radio frequencies may exist outside of EU markets.	

Hereby, Polaris Industries Inc. declares that the above radio equipment is in compliance with Directive 2014/53/EU.

The full text of the EU declaration of conformity is available at the following internet address:

<https://www.polaris.com/en-us/radio-conformity/>

## RIDE COMMAND DISPLAY (IF EQUIPPED)





### OVERVIEW





- ① Ride Command Buttons
- ② Driveline Mode
- ③ Widgets
- ④ Settings

- ⑤ Icon Bar
- ⑥ Gauge View Mode
- ⑦ Speedometer/Tachometer
- ⑧ Gear Status

## RIDE COMMAND BUTTONS

BUTTON	DESCRIPTION	FUNCTION
	<p>Menu Button</p>	<p>Press the Menu button to access the settings. To reboot the display, press and hold for 5 seconds.</p>
	<p>Gauge Screen Button</p>	<p>Press the Gauge Screen button to select from available screens.</p>
	<p>Map Button</p>	<p>Press the Map button to access the map, manage your rides and waypoints, and to see your friends on the map with Group Ride.</p>
	<p>Phone Button</p>	<p>Press the Phone button to access your Bluetooth® connected phone, including recent calls, contacts, dialer, and messages.</p>
	<p>Audio Button</p>	<p>Press the Audio button to access the Radio, Weather, USB, and connected Bluetooth® music interface</p>

## RIDE COMMAND DISPLAY (IF EQUIPPED)

BUTTON	DESCRIPTION	FUNCTION
	Volume Decrease Button	Press the Volume Decrease button to decrease the volume. Press and hold to mute volume.
	Volume Increase Button	Press the Volume Increase button to increase the volume.

### **PIN ACTIVATED SECURITY SYSTEM (P.A.S.S.) (IF EQUIPPED) — RIDE COMMAND**

The optional PIN Activated Security System (P.A.S.S.) is to prevent unauthorized use. When enabled, the vehicle cannot be operated until a valid passcode has been entered using the Ride Command display screen.

#### **ENABLE P.A.S.S.**

##### *NOTICE*

After activating P.A.S.S. for the first time you must power down the vehicle and allow the electronic control module (ECM) to fully shutdown before restarting. This may take up to three minutes.

1. Go the settings menu by pressing the Menu button.
2. Select Vehicle Settings from the left toolbar.
3. Select Engine Start Lockout.
4. If this your first time activating P.A.S.S. you will be prompted to enter a new passcode. Enter and verify new passcode.  
Please record your passcode.
5. Turn Engine Start Lockout from No to Yes.
6. Turn off the vehicle using the key ignition switch.

##### *NOTICE*



If the battery becomes low while the P.A.S.S. system is enabled, the gauge may show "New Vehicle Detected" after the battery has been recharged/replaced. Leave the key in the ON position to allow system reconfirmation.

#### **DISABLE P.A.S.S.**

1. Go the settings menu by pressing the Menu button.
2. Select Vehicle Settings from the left toolbar.
3. Select Engine Start Lockout.
4. Enter passcode to disable P.A.S.S.
5. Turn Engine Start Lockout from Yes to No.

## RIDE COMMAND DISPLAY (IF EQUIPPED)

### DRIVELINE MODE

ICON	DRIVELINE MODE	DESCRIPTION
	All Wheel Drive (AWD)	When in All-Wheel Drive, the front drive is engaged with the front differential. The locked state drives all wheels at the same speed which will increase steering effort and changes the handling characteristics from the AWD mode. If switched to AWD Lock when vehicle speed, accelerator pedal position, and engine RPM are above activation limits, AWD Lock will not engage until vehicle speed, accelerator pedal position, and engine RPM are decreased.
	Two Wheel Drive (2WD) Locked	Operating in 2WD will lock the rear differential, meaning both rear wheels are powered. In 2WD, both rear wheels will rotate at the same speed. Using 2WD in slippery or low traction conditions helps improve traction when AWD may not be required.
	Differential Unlock (TURF mode)	Operating in Turf Mode unlocks the rear differential and divides power flow between the left and right wheels, while allowing them to rotate at different speeds during cornering where the outside wheel needs to travel further than the inside wheel. This prevents axle torque wind-up that damages the turf. Both wheels will drive with equal torque, but this torque magnitude is limited to the tractive torque available at the wheel with the least traction. For example, if one tire is off the ground and has no traction, all power will flow to that wheel (path of least resistance) causing it to accelerate and spin. No driving torque will go to the other wheel with traction.

### GAUGE SCREENS

Press the Gauge Screen button to toggle between gauge screens. The display comes loaded with two different gauge screens. Additional gauge screens can be added or deleted.



## RIDE COMMAND DISPLAY (IF EQUIPPED)

Each gauge screen is customizable and can be set up in the following configurations:

- Four round widgets
- Two round widgets and a list of three data values
- A list of five data values

To customize your gauge screens, press the gear icon located in the lower right corner of the display.



## SETTINGS

From the setting menu you can view vehicle information, manage Bluetooth® devices, update display software, and more.

To access the Setting menu, press the Menu button ①.

You can also navigate to the settings menu by pressing the POLARIS logo at the top of the display screen ②. This will open the Control Panel. From the Control Panel, select the settings tab, then press the **All Settings** button located in the lower right corner of the display screen.



## RIDE COMMAND DISPLAY (IF EQUIPPED)

### GAUGE VIEW MODE

Press ① to toggle between the two available gauge view modes, **Analog** and **Digital**.

While in the digital gauge view mode, press ② to invert the MPH and RPM units.



### DISPLAY MODE

From the Control tab ③, select the display mode from the available options ④.

The display mode can be set to Day, Night, or AUTO mode.

#### Day Mode



#### Night Mode



## RIDE COMMAND DISPLAY (IF EQUIPPED)

### ICON BAR



ICON	DESCRIPTION	FUNCTION
①	Headset	Displays icon if headset is connected
②	Signal Strength	Displays current cell signal strength
③	Wireless Internet Signal Strength (if equipped)	Displays current wireless internet signal strength (if equipped)
④	Fuel Level	Displays current fuel capacity percentage
⑤	Vehicle Direction	Displays vehicle direction
⑥	Ambient Temperature	Displays ambient temperature
⑦	Clock	Displays current time

## RIDE COMMAND DISPLAY (IF EQUIPPED)

---

### UPDATE SOFTWARE

#### NOTICE

Before updating the Display, always export your existing rides and waypoints to a USB drive to avoid losing them.

To update the software, do the following:

#### ON YOUR PERSONAL COMPUTER

1. Go to [ridecommand.polaris.com/update](http://ridecommand.polaris.com/update).
2. Log into your account, or create a new account.
3. Using the Vehicle Identification Number (VIN), add your new Polaris vehicle to your Garage.
4. Locate and download the latest software to a USB flash drive (8+ GB).

#### ON YOUR VEHICLE

1. Connect the USB flash drive to the USB cable and power up your vehicle.
2. On the RIDE COMMAND display, select the Settings menu on your display by pressing the POLARIS icon at the top of the screen.
3. Select General Settings, then Update Software.
4. Select the file you wish to load (use date listed in the file name to determine most recent file).
5. Select Yes to restart display (restart required).

#### ERROR MESSAGES

If an error occurs while updating your software, perform one or all of the following actions to resolve the issue:

1. Remove and reconnect the USB flash drive securely.
2. Make sure the display files are not inside a folder on the flash drive.
3. Make sure only display files are on the flash drive. Remove any other files if necessary.
4. Try using a different USB flash drive.

### UPDATE MAPS

To update the maps on your display, do the following:

1. Go to [ridecommand.polaris.com/update](http://ridecommand.polaris.com/update) and download the map update to a USB flash drive.
2. Insert USB flash drive into the USB port on your vehicle.
3. Press the Update maps in the General Settings.
4. Select the file you want to install by pressing the corresponding down arrow icon.
5. This will update the display's map which will automatically restart the display once the update is complete. Do not remove the USB flash drive until the display has fully restarted.

### USB HARDWARE

#### SOFTWARE UPDATES

For software update, POLARIS recommends using a SanDisk® or similar USB flash drive with a minimum of 4GB in available memory, formatted using the FAT32 or exFAT® file systems. For best results remove all files from the flash drive before starting the update process.

#### MAP UPDATES

For Map updates, a 32GB USB drive is required (USB 3.0 drive is highly recommended) USB drive must be formatted to exFAT® before copying the map file onto it.

#### TRAIL UPDATES

For Trail updates, a 4GB drive formatted to FAT32 can be used.

### RIDE COMMAND+ (IF EQUIPPED)

Your vehicle may come equipped with RIDE COMMAND+ technology, which gives you access to your vehicle's custom information including Vehicle Health, Vehicle Locator and Issue Diagnostics along with a variety of features via the Polaris mobile app. You will need a cellular connection to view these features.

## RIDE COMMAND DISPLAY (IF EQUIPPED)

---

To learn more about RIDE COMMAND+, including equipped or compatible vehicles, specific features, and to access the RIDE COMMAND+ User Guide, visit [ridecommand.polaris.com/ridecommand+](http://ridecommand.polaris.com/ridecommand+) or scan the QR code below:



*Disclaimer: RIDE COMMAND+ only available in North America.*

---

## OPERATION

### VEHICLE BREAK-IN

#### ENGINE AND DRIVETRAIN BREAK-IN

1. Fill the fuel tank with the recommended fuel. See the Refueling section for details. Always exercise extreme caution whenever handling fuel.
2. Check the oil level. See the Oil Check section for details. Add the recommended oil as needed to maintain the oil level in the safe operating range.
3. Avoid aggressive use of the brakes.
4. Vary throttle positions. Do not operate at sustained idle.
5. Perform regular checks on fluid levels, controls and areas outlined on the daily pre-ride inspection checklist.
6. Carry only light loads.
7. During the break-in period, change both the oil and the filter at 25 hours, one month, or 500 miles, whichever comes first.
8. Check fluid levels of transmission and all gearcases according to the Maintenance Schedule.

#### BRAKE SYSTEM BREAK-IN

Apply only moderate braking force for the first 50 stops. Aggressive or overly forceful braking when the brake system is new could damage brake pads and rotors.

#### PVT BREAK-IN (CLUTCHES / BELT)

A proper break-in of the clutches and drive belt will ensure a longer life and better performance. If a belt fails, always clean any debris from the duct and from the engine compartment.

#### **STANDARD BREAK-IN**

Drive at slower speeds for the first 50 miles (80 km) of operation. Carry only light loads. Avoid aggressive acceleration, high-speed operation and prolonged operation at a specific RPM during this period.

#### **SAND / DUNE BREAK-IN**

Drive in low gear for the first 5 miles (8 km) of operation. Avoid prolonged low speed operation at high throttle. Avoid aggressive acceleration, high-speed operation and prolonged operation at a specific RPM during this period.

#### **BELT LIFE**

To extend belt life, use low gear in the following conditions:

## OPERATION

---

- When hauling or towing heavy cargo
- When consistently operating at speeds less than 30 MPH (48 km/h) in hard-pulling terrain, such as mud, rocks or sand/dune environments.

## OPERATING GUIDELINES

### FUEL RECOMMENDATION

Polaris recommends using fresh Unleaded 91 Octane TOP TIER® Detergent Gasoline containing up to 10% ethanol purchased during the season of vehicle usage. This fuel will provide the best engine performance (starting, run quality, fuel economy, and power) and durability.

#### Octane Rating

Polaris recommends a minimum of 87 Octane (R+M/2) rated gasoline. Using lower octane gasoline could result in engine damage.

#### Ethanol Content

Polaris recommends gasoline containing up to 10% ethanol (E10). Higher levels of ethanol (ex. E15 and E85) may result in engine damage.

#### Detergent Gasoline

Polaris recommends Top Tier® Detergent Gasoline to keep the engine cleaner by reducing carbon deposits, which will help maintain engine performance and durability. Refer to [www.toptiergas.com](http://www.toptiergas.com) for a list of TOP TIER® Detergent Gasoline retailers. Alternatively, the logo shown below on the retailer's fuel pump will confirm that TOP TIER® Detergent Gasoline is being dispensed.



If TOP TIER® Detergent Gasoline is not available, adding Polaris Carbon Clean to the fuel tank at every oil change will help reduce carbon deposits.

#### Seasonal Blends

Polaris recommends using gasoline that is purchased during the season the vehicle is being used, especially summer vs. winter. Between seasons, refineries typically change the gasoline blend to avoid temperature induced engine performance issues. Winter blend gasoline improves engine starting in cold weather and summer blend gasoline helps prevent vapor lock issues in hot weather.



---

## STARTING THE ENGINE

### NOTICE

Operating the vehicle immediately after starting could cause engine damage. Allow the engine to warm up for several minutes before operating the vehicle.

1. Position the vehicle on a level surface outdoors or in a well-ventilated area.
2. Sit in the driver's seat and fasten the seat belt. Always make sure all cab doors are closed and latched when riding in this vehicle.
3. Place the transmission in PARK.
4. Apply the brakes. Do not press the throttle pedal while starting the engine.
5. Turn the ignition key past the ON/RUN position and release immediately to START. The engine will turn over for a maximum five seconds until the vehicle has started.
6. If the engine does not start within five seconds, return the ignition switch to the OFF position and wait five seconds. Repeat steps 5 and 6 until the engine starts.
7. After starting the engine, wait 10 seconds before applying throttle.

## BRAKING

1. Release the throttle pedal completely.

### TIP

When the throttle pedal is released completely and engine speed slows to near idle, the vehicle has no engine braking.

2. Press on the brake pedal evenly and firmly.
3. Practice starting and stopping (using the brakes) until you're familiar with the controls.

## OPERATION

---

### DRIVING IN REVERSE



Before shifting into reverse, use extra care to make sure the area is clear of people or obstacles. When it's safe to proceed, back slowly.

Follow these precautions when operating in reverse:

1. Always check for obstacles or people behind the vehicle.
2. Apply the throttle *lightly*. Never open the throttle suddenly.
3. Back slowly.
4. Apply the brakes *lightly* for stopping.
5. Avoid making sharp turns.

### STOPPING THE ENGINE AND PARKING THE VEHICLE



When leaving the vehicle on an incline is unavoidable, use extra care. Vehicle rollaway can cause serious injury or death. This vehicle can roll whenever the gear selector is not in the PARK (P) position. Always shift to PARK (P) when stopping the engine or leaving the vehicle. If leaving the vehicle unattended, block the rear wheels on the downhill side and keep children, pets, and others away from the gear selector.

To park the vehicle:

1. Stop the vehicle on a level surface.
2. Place the transmission in PARK (P). This vehicle can roll whenever the transmission is not in the PARK (P) position.
3. Stop the engine.
4. Engage the park brake (if equipped).
5. Remove the ignition key to prevent unauthorized use.

## ALL WHEEL DRIVE/REAR DIFFERENTIAL SYSTEM (AWD)

If your model is equipped with a lockable differential, you can choose to operate with an open differential or a closed differential.

### ENGAGING AWD

Press the top of the switch to engage All Wheel Drive (AWD). The 4X4 indicator illuminates in the rider information center to indicate that the vehicle is in AWD.

When the AWD switch is on, the front gearcase will automatically engage any time the rear wheels lose traction. When the rear wheels regain traction, the front gearcase will automatically disengage. There is no limit to the length of time the vehicle may remain in AWD.

Initially, the vehicle's electronic system will not enable the AWD until the engine RPM is below 3100. Once enabled, the AWD remains enabled until the AWD switch is turned off. If the switch is turned off while the front gearcase is moving, it will not disengage until the rear wheels regain traction.

- ① All-Wheel Drive (AWD)
- ② Differential Lock
- ③ Differential Unlock

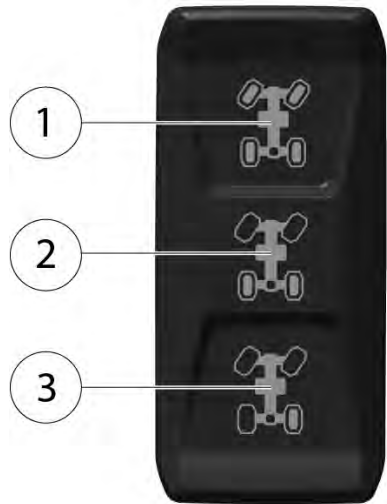

Engage the AWD before getting into conditions where front wheel drive may be needed. If the rear wheels are spinning, release the throttle before switching to AWD.

### DISENGAGING AWD

Move the AWD switch to the center or bottom position to disengage AWD. If the switch is turned off while the front hubs are driving, they will not release until the rear wheels regain traction.

## OPERATION

---

In some situations, the front gearcase may remain locked after turning the AWD switch off. If this occurs, you may notice increased steering effort and some vehicle speed restriction. Perform the following procedure to unlock the front gearcase.

To disengage AWD, do the following:

1. Stop the vehicle.
2. Operate in reverse for at least 10 feet (3 m).
3. Stop completely.
4. Shift into low gear and drive forward.
5. If the front gearcase remains locked after following these instructions, see your dealer or other qualified service person for service.

### **LOCKING THE DIFFERENTIAL**

Move the rocker switch to the center position to lock the differential and operate in two wheel drive (2WD). Locking the differential in slippery or low traction conditions helps improve traction. When the rear differential is locked, both rear wheels rotate at the same speed.

### **UNLOCKING THE DIFFERENTIAL (TURF MODE)**

When operating in TURF mode, the inside rear wheel will rotate independently from the outside wheel during turns. Operate in TURF mode only as needed to protect smooth, level surfaces from tire damage. DO NOT operate in TURF mode when climbing or descending hills, when sidehilling, or when operating on uneven, loose, or slippery terrain such as sand, gravel, ice, snow, obstacles, and water crossings. Always operate in AWD on these types of terrain.

#### WARNING

Operating in TURF mode (if equipped) when on sloped, uneven, or loose terrain could cause loss of control and result in serious injury or death. One rear wheel may slip and lose traction or may lift up and grab when it touches the ground again.

Press the bottom of the switch to unlock the differential and allow the rear drive wheels to operate independently (1WD). When the rear differential is unlocked, the rear wheels can rotate at different speeds. Unlock the differential to make maneuvering easier and minimize damage to turf.

#### NOTICE

Damage to the differential can occur if it is engaged while the vehicle is traveling at high speeds or while the rear wheels are spinning. Slow the vehicle to nearly stopped before engaging the differential.

 **WARNING**

Never operate in TURF mode (if equipped) while operating on a hill or other irregular terrain. Always move the AWD switch to AWD before ascending or descending a hill.

## HAULING CARGO

 **WARNING**

Hauling cargo improperly can alter vehicle handling and may cause loss of control or brake instability, which can result in serious injury or death.

 **WARNING**

Always follow these precautions when hauling cargo:

- Never exceed the maximum weight capacity of the vehicle. When determining the weight you are adding to the vehicle, include the weight of the operator, passengers, non-factory installed accessories, loads in the rack or box and the load on the trailer tongue. The combined weight of these items must not exceed the maximum weight capacity.
- **REDUCE SPEED AND ALLOW GREATER DISTANCES FOR BRAKING WHEN HAULING CARGO.**
- Always load the cargo box with the load as far forward and as low as possible.
- When operating over rough or hilly terrain, reduce speed and cargo to maintain stable driving conditions.
- Always operate the vehicle with extreme care when hauling or towing loads.
- Slow down and drive in the lowest gear available. When transporting heavy loads and/or when towing, always operate the vehicle in low gear and have ADC activated (if equipped).

## OPERATION

### WARNING

- **SECURE ALL LOADS BEFORE OPERATING.** Unsecured loads can create unstable operating conditions, which could result in loss of control of the vehicle.
- **OPERATE ONLY WITH STABLE AND SAFELY ARRANGED LOADS.** When handling off-centered loads that cannot be centered, securely fasten the load and operate with extra caution. Always attach the tow load to the hitch point designated for your vehicle.
- **HEAVY LOADS CAN CAUSE BRAKING AND CONTROL PROBLEMS.** Use extreme caution when applying brakes with a loaded vehicle. Avoid terrain or situations that may require backing downhill.
- **USE EXTREME CAUTION** when operating with loads that extend over the rack sides. Stability and maneuverability may be adversely affected, causing vehicle rollover.
- **DO NOT TRAVEL FASTER THAN THE RECOMMENDED SPEEDS.** Vehicle should never exceed 10 MPH (16 km/h) while towing a load on a level grass surface. Vehicle speed should never exceed 5 MPH (8 km/h) when towing loads in rough terrain, while cornering, or while ascending or descending an incline.

Your POLARIS vehicle has been designed to carry or tow specific capacities. Always read and understand the load distribution warnings listed on the warning labels. The total load (operator, passengers, non-factory installed accessories, cargo and weight on hitch) must not exceed the maximum weight capacity of the vehicle. See the Safety chapter for details.

### WARNING

Driving with passengers in the cargo box can result in severe injury or death. Never allow passengers to ride in the cargo box. Passengers must always ride in the cab with seat belts fastened securely.

## **TOWING LOADS**

Towing improperly can alter vehicle handling and may cause loss of control or brake instability. Always follow these precautions when towing:

1. Never load more than 200 lbs. (91 kg) tongue weight on the towing bracket.
2. When transporting heavy loads and/or when towing, always operate the vehicle in low gear and have ADC activated (if equipped).
3. Do not operate the vehicle faster than 10 MPH (16 km/h) when towing. Towing a trailer increases braking distance.

4. Do not tow more than the recommended weight for the vehicle. See the towing capacity chart below and the Specifications section for towing values.
5. Attach a trailer to the trailer hitch bracket only. Do not attach a trailer to any other location, which could result in loss of control of the vehicle.
6. Avoid towing loads on an incline. If it's unavoidable, choose the smallest incline available, operate with extreme caution, and drive straight up or down the incline.

TOTAL TOWED LOAD WEIGHT (LEVEL GROUND)	TOTAL HITCH VERTICAL WEIGHT	MAXIMUM TOWING SPEED
2000 lbs. (907 kg)	200 lbs. (91 kg)	10 MPH (16 km/h)

**NOTE**

To extend belt life, use low gear when hauling or towing heavy cargo.

## OPERATION

### TOWING THE POLARIS XPEDITION

Towing this vehicle is not recommended. Always transport the vehicle on a trailer or flatbed with all four wheels off the ground. See the Transporting the POLARIS XPEDITION section for details.

If towing a disabled vehicle is unavoidable, place the disabled vehicle's transmission in neutral. Tow the shortest distance possible. Do not operate faster than 10 MPH (16 km/h).

### TRANSPORTING THE POLARIS XPEDITION

Follow these procedures when transporting the vehicle.

1. Place the transmission in PARK. Stop the engine.
2. Slowly release the brake pedal and make sure the transmission is in PARK before exiting the vehicle.
3. Remove the key to prevent loss during transporting.
4. Secure the fuel cap, hood, doors, and cargo box. Ensure that the seats are attached correctly and are not loose.

#### WARNING

Cargo and other loose vehicle parts may fly off while transporting this vehicle. Secure or remove all cargo, and inspect the unit for loose parts prior to transport.

When transporting vehicle in non-enclosed trailer, vehicle must **FACE FORWARD**. Windshield and all windows, doors, and rear liftgate (if equipped) must be **FULLY CLOSED** and **LATCHED**. Failure to comply may allow airflow, vibration, or other factors to separate the windshield, doors, roof, or rear liftgate (if equipped) from vehicle and cause an accident, resulting in serious injury or death.

5. Always tie the frame  of the POLARIS vehicle to the transporting unit securely with suitable straps or rope. Do not attach tie straps to the front A-arm bolt pockets.

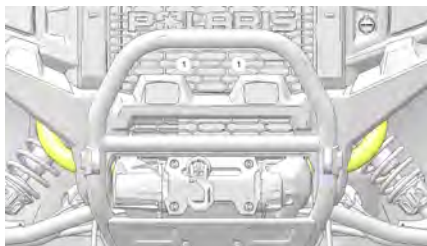



# EMISSION CONTROL SYSTEMS

## NOISE EMISSION CONTROL SYSTEM

Do not modify the engine, intake or exhaust components, as doing so may affect compliance with U.S.A. EPA noise control requirements (40 CFR 205) and local noise level requirements.

## OPERATION ON PUBLIC LANDS IN THE U.S.A.

Your vehicle has a spark arrestor that was tested and qualified to be in accordance with the USFS standard 5100-1D. Federal law requires that this spark arrestor be installed and functional when the vehicle is operated on public lands.

Operation of off-road vehicles on public lands in the U.S.A. is regulated by 43 CFR 420. Violations are subject to monetary penalties. Federal regulations can be viewed online at <https://ecfr.federalregister.gov/current/title-43/subtitle-B/chapter-1/part-420>.

## CRANKCASE EMISSION CONTROL SYSTEM

This engine is equipped with a closed crankcase system. Blow-by gases are forced back to the combustion chamber by the intake system. All exhaust gases exit through the exhaust system.

## EXHAUST EMISSION CONTROL SYSTEM

Exhaust emissions are controlled by engine design. An electronic fuel injection (EFI) system controls fuel delivery. The engine and EFI components are set at the factory for optimal performance and are not adjustable.

The emissions label is located on the inside of the lower left frame tube (below driver's foot area).

## ELECTROMAGNETIC INTERFERENCE

This spark ignition system complies with Canadian ICES-002.

This vehicle complies with the EMC requirements of UN ECE Regulation 10.

Non-ionizing Radiation: This vehicle emits some electromagnetic energy. People with active or non-active implantable medical devices (such as heart monitoring or controlling devices) should review the limitations of their device and the applicable electromagnetic standards and directives that apply to this vehicle.



## MAINTENANCE

### OVERVIEW

Any qualified repair shop or person may maintain, replace or repair the emission control devices or systems on your vehicle. An authorized POLARIS dealer can perform any service that may be necessary for your vehicle. POLARIS also recommends POLARIS parts for emissions-related service, however equivalent parts can be used.

It is a potential violation of the EU law if a part supplied by an aftermarket parts manufacturer reduces the effectiveness of the vehicle's emission controls. Tampering with emission controls is prohibited by law.

Owners are responsible for performing the scheduled maintenance identified in this owner's manual. Careful periodic maintenance will help keep your vehicle in safe, reliable condition. Inspect, clean, lubricate, adjust and replace parts as necessary. When inspection reveals the need for replacement parts, genuine POLARIS parts are available from your POLARIS dealer. Equivalent parts may be used for emissions-related service.

Record maintenance and service in the Maintenance Log beginning on page 183. Service and adjustments are important for proper vehicle operation. If you're not familiar with safe service and adjustment procedures, a qualified dealer can perform these operations. Maintenance intervals in the following chart are based upon average riding conditions and an average vehicle speed of approximately 10 miles per hour. Vehicles subjected to severe use must be inspected and serviced more frequently.

## MAINTENANCE

---

### **POLARIS MAINTENANCE SCHEDULE**

The intervals shown are based on vehicles operated under normal conditions.

Each interval is given in hours and miles (kilometers). Items should be serviced at whichever interval comes first following the **Initial Break-In Service**.

Continue to reference the following maintenance schedules at the given intervals as hours and miles (kilometers) increase on the vehicle.

*Vehicles subjected to severe use must be serviced at 50% of the stated interval. Examples of Severe Use: Frequent immersion in mud, water, or sand, constant high RPM use, prolonged low-speed heavy load operation, extended idle, and short trip cold weather operation.*

#### **INITIAL BREAK-IN SERVICE FIRST 25 HOURS / 500 MILES (800 KM) / 1 MONTH**

Engine Oil and Filter	Change the engine oil and filter.
Front Gearcase Fluid	Change fluid.
Transmission Fluid	Change fluid.
Clutches*	Inspect bushings, rollers, wearable parts; clean; replace worn parts.
Drive Belt	Inspect; replace as needed.
The break-in period consists of the first 25 hours of operation. Careful treatment of a new engine and drive components will result in more efficient performance and longer life for these components. The items outlined in this service interval only need to be performed at the first 25 hours of operation. They do not need to be performed every 25 hours.	
* It is recommended to have an authorized Polaris dealer perform these services.	

*Vehicles subjected to severe use must be serviced at 50% of the stated interval. Examples of Severe Use: Frequent immersion in mud, water, or sand, constant high RPM use, prolonged low-speed heavy load operation, extended idle, and short trip cold weather operation.*

## IMPORTANT

The following maintenance items will be performed for the first time when the vehicle has 75 hours / 1500 miles (2400 km) unless already performed.

### EVERY 50 HOURS / 1000 MILES (1600 KM) OR YEARLY FOLLOWING INITIAL BREAK-IN SERVICE

Air Filter	Inspect; replace as needed. Ensure proper installation of filter and airbox cover. Inspect ducts and screens; clean as necessary.
Brake Pads, Brake Lines/ Hoses	Inspect; replace as needed.
Brake System	Fluid level inspection; inspect for fluid leaks; add fluid if needed. Inspect brake pad wear.
Battery	Check terminals; terminals should be tight and free of corrosion. Clean, test, and replace as necessary.
Engine Oil and Filter	Change the engine oil and filter.
Exhaust / Silencer Pipe	Inspect.
Fuel System*	Cycle key to pressurize fuel pump; check for leaks at fuel system connections, check for leaks at fill cap.
General Lubrication	Lubricate all applicable fittings.
Spark Plugs	Inspect; replace as needed.
Wiring Harness / Connections	Inspect; Adjust / Clean as needed.
Drive Belt	Inspect; replace as needed.
Clutches*	Inspect bushings, rollers, wearable parts; clean; replace worn parts.
Wheel Bearings	Inspect; replace as needed
Throttle Body / Intake Ducts / Flanges	Inspect ducts for proper sealing / air leaks

## MAINTENANCE

---

### **EVERY 50 HOURS / 1000 MILES (1600 KM) OR YEARLY FOLLOWING INITIAL BREAK-IN SERVICE**

Steering Components	Inspect; replace as needed.
Suspension Components / Alignment*	Inspect front and rear suspension bushings, and ball joints for loose or worn components; replace as needed. Inspect shock absorbers for leaks or damage. Adjust suspension where applicable.
Tires	Inspect; Adjust pressure level as needed; Inspect wear and replace as needed.
* Have an authorized Polaris dealer or other qualified person perform these services.	

*Vehicles subjected to severe use must be serviced at 50% of the stated interval. Examples of Severe Use: Frequent immersion in mud, water, or sand, constant high RPM use, prolonged low-speed heavy load operation, extended idle, and short trip cold weather operation.*

## ADDITIONAL MAINTENANCE INTERVALS

<b>Every 2000 miles (3200 km) / 12 months / 1 year following Initial Break-In Service</b>	Front Gearcase Fluid**	Change fluid.
	Transmission Fluid	Change fluid.
<b>Every 2000 miles (3200 km)</b>	Shock Absorbers*	Inspect; replace or rebuild (if applicable).
<b>Every 3000 miles/ 30 months/ 150 hours</b>	Spark Arrestor	Inspect; Clean as needed. Replace as needed.
<b>Every 10000 miles (16000 km)</b>	Valve Clearance*	Inspect; adjust as needed.
<b>Every 24 months</b>	Brake Fluid	Change fluid.
<b>Every 60 months</b>	Coolant	Change fluid.
<p>* Have an authorized Polaris dealer or other qualified person perform these services.                      **This service will be completed first at 500 miles (800 km) during the break-in service, next at 2500 miles (4000 km), and every 2000 miles (3200 km) following.</p>		

## LUBRICATION RECOMMENDATIONS

Check and lubricate all components at the intervals outlined in the Maintenance section, or more often under severe use, such as wet or dusty conditions. Items not listed in the chart should be lubricated at the general lubrication interval.

ITEM	LUBE	METHOD
Engine Oil	PS-4 5W-50 4-Cycle Oil	Add to proper level on dipstick. See the Engine Oil Level section.
Brake Fluid	DOT 4 Brake Fluid	Maintain level between fill lines. See page 130.
Main Gearcase Oil (Transmission)	AGL Gearcase Lubricant & Transmission Fluid	See page 113

# MAINTENANCE

ITEM	LUBE	METHOD
Front Gearcase Oil	Demand Drive Fluid	See page 114.
Front Prop Shaft Yoke	U-Joint Grease	Locate fittings and grease (3 pumps maximum).



## ENGINE OIL

Always check and change the oil at the intervals outlined in the Polaris Maintenance Schedule. Always use the recommended engine oil. Always change the oil filter whenever changing oil.

Pay special attention to the oil level. A rise in oil level during cold weather can indicate contaminants collecting in the oil sump or crankcase. Change oil immediately if the oil level begins to rise. Monitor the oil level, and if it continues to rise, discontinue use and determine the cause. Your dealer can assist.

### WARNING

Vehicle operation with insufficient, deteriorated, or contaminated engine oil will cause accelerated wear and may result in engine seizure, accident and injury. Always perform the maintenance procedures as outlined in the Polaris Maintenance Schedule.

## OIL RECOMMENDATIONS

POLARIS recommends the use of POLARIS PS-4 5W-50 4-Cycle Oil or a similar oil. Refer to the Specifications section for capacities.

Oil may need to be changed more frequently if POLARIS PS-4 engine oil is not used. Follow the manufacturer's recommendations for ambient temperature operation. See the Polaris Products section for part numbers.

### NOTICE

Mixing brands or using a non-recommended oil may cause serious engine damage. Always use the recommended oil. Never substitute or mix oil brands.

## MAINTENANCE

---

### ENGINE OIL LEVEL

1. Position vehicle on a level surface and place the transmission in PARK.
2. Stop the engine and allow it to cool down before removing the dipstick.
3. Unlock the dipstick lever ① on the right side of the engine through the RH rear wheel opening. Remove the dipstick and wipe it dry with a clean cloth.

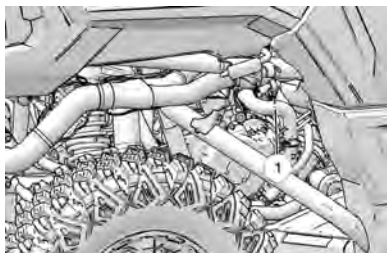

Non-NorthStar Units

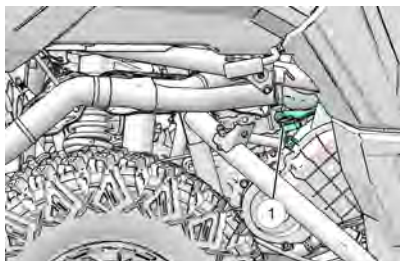

NorthStar Units

4. Reinstall the dipstick and push it into place. Do not lock the dipstick.

#### *NOTICE*

Make certain the dipstick is inserted all the way into the dipstick tube to keep the depth of the dipstick consistent.

5. Remove the dipstick and check the oil level.

6. Add the recommended oil as necessary to bring the oil level within the SAFE range on dipstick. Do not overfill (see NOTE below).

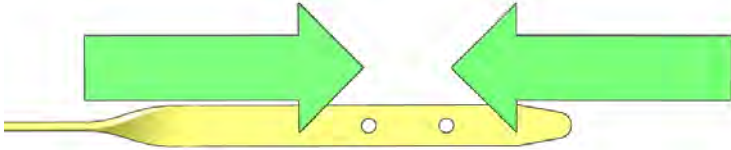

### *NOTICE*

A rising oil level between checks during cold weather operation can indicate contaminants such as gas or moisture collecting in the crankcase. If the oil level is over the upper mark, change the oil immediately.

## MAINTENANCE

7. To access oil fill cap, remove the cargo box access panel ② to locate the oil fill cap.

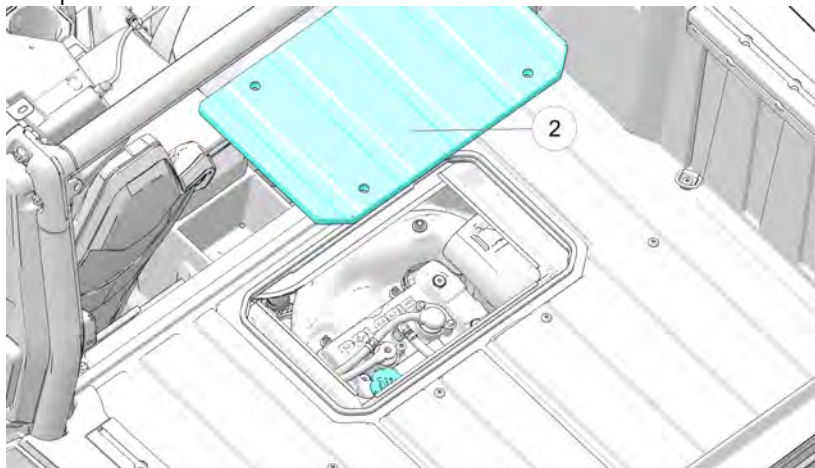

8. When finished, reinstall dipstick and lock the lever. Reinstall the cargo box access panel.

## OIL AND FILTER CHANGE (NON-NORTHSTAR MODELS)

Always change the oil and filters at the intervals outlined in the Polaris Maintenance Schedule. Always change the oil filter whenever changing oil.

### NOTICE

Warm the engine for 2–3 minutes before performing the oil change procedure.

The crankcase drain plug is located on the bottom of the crankcase. Access the drain plug through the access hole in the skid plate under the crankcase (see next page).

Access the oil fill cap under the cargo box access panel.

1. Position vehicle on a level surface and place the transmission in PARK.
2. Locate the crankcase drain plug access hole in the skid plate.
3. Clean the area around the crankcase drain plug.

### CAUTION

Hot oil can cause burns to skin. Do not allow hot oil to contact skin.

4. Place a drain pan under the engine crankcase and remove the drain plug ① and sealing washer. Allow the oil to drain completely.

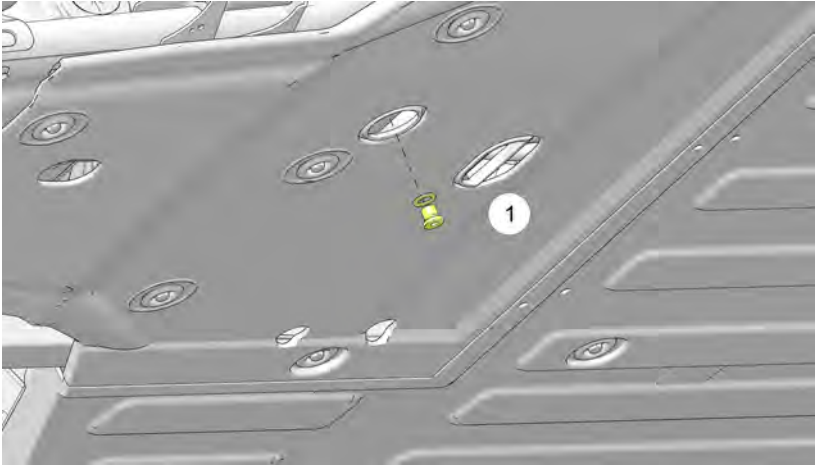

5. Using an extension, swivel, and oil filter wrench, turn the filter ② counter-clockwise to remove it.

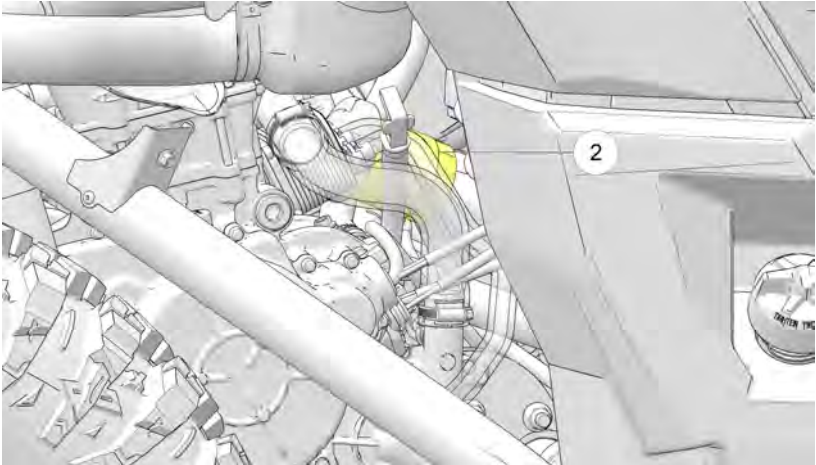

6. Using a clean dry lint free cloth, clean the filter sealing surface on the crankcase.
7. Lubricate the O-ring on the new oil filter with a film of fresh engine oil. Check to make sure the O-ring is in good condition.
8. Install the new oil filter by hand in a clockwise direction until the filter gasket contacts the sealing surface. Then, turn an additional 3/4 turn.

## MAINTENANCE

---

9. Replace the sealing washer on the drain plug.

### NOTICE

The sealing surface on the drain plug should be clean and free of burrs, nicks or scratches.

10. Reinstall the drain plug.

### TORQUE

**Drain Plug Torque:  
12 ft-lbs (16 Nm)**

11. Remove the engine access panel in the cargo box.
12. Remove the oil fill cap ③ and add 2.5 quarts (2.4 l) of recommended oil. Reinstall the fill cap.

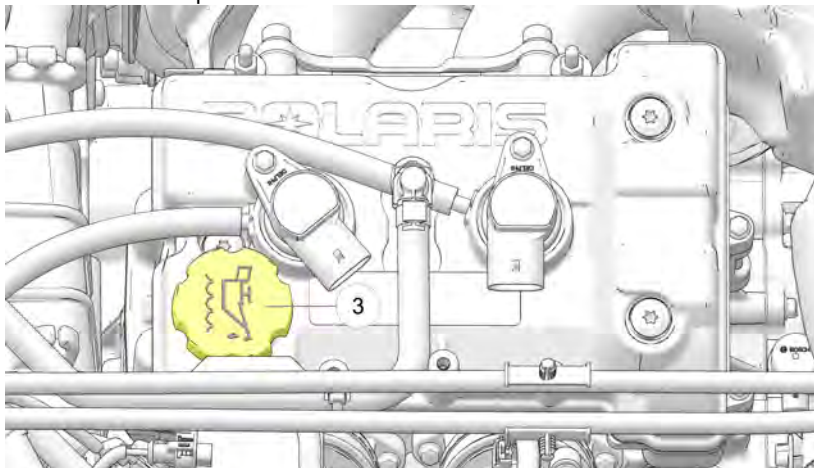

13. Start the engine and check for leaks.
14. Stop the engine and wait 15 seconds before removing the dipstick.

15. Remove the dipstick ④. Wipe it dry with a clean cloth.

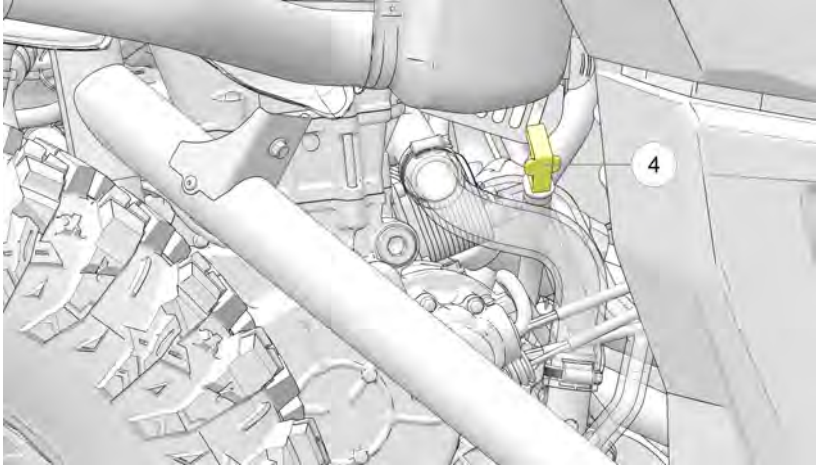

16. Reinstall the dipstick completely. Remove the dipstick and check the oil level.
17. Remove the oil fill cap and add oil as needed to bring the level to the upper mark on the dipstick. Do not overfill.
18. Reinstall the fill cap. Reinstall the dipstick.
19. Reinstall the engine access panel.
20. Dispose of used filter and oil properly.

## MAINTENANCE

### ENGINE OIL AND FILTER CHANGE (NORTHSTAR MODELS ONLY)

Always change engine oil and filter at the intervals outlined in the Polaris Maintenance Schedule. Always change the oil filter whenever changing the engine oil.

The crankcase drain plug is located on the bottom of the crankcase, under the skid plate.

#### CAUTION

Use caution when performing this procedure. Do not allow hot engine oil to come into contact with skin, as serious burns may result.

1. Position vehicle on a level surface and place the transmission in PARK.
2. Stop the engine and allow it to cool down.
3. Remove rear skid plate by removing its fasteners ①.

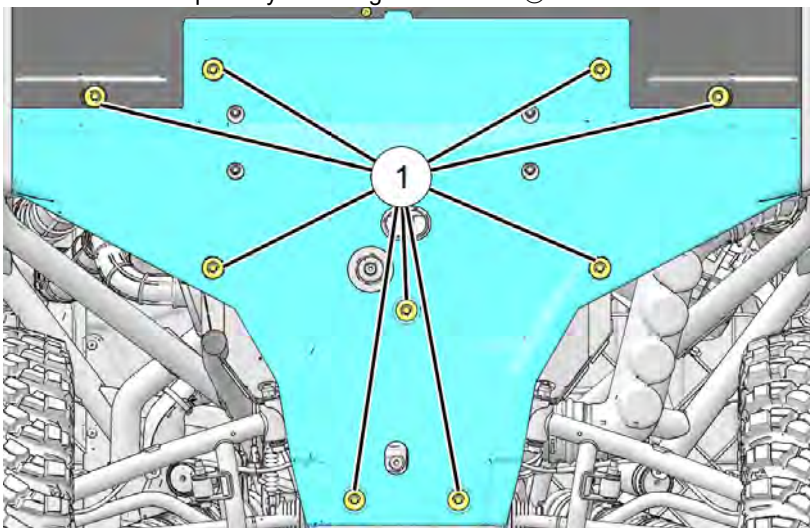

4. Clean the area around the crankcase drain plug.



5. Place a drain pan under the engine crankcase and remove the drain plug ②. Allow the oil to drain completely.

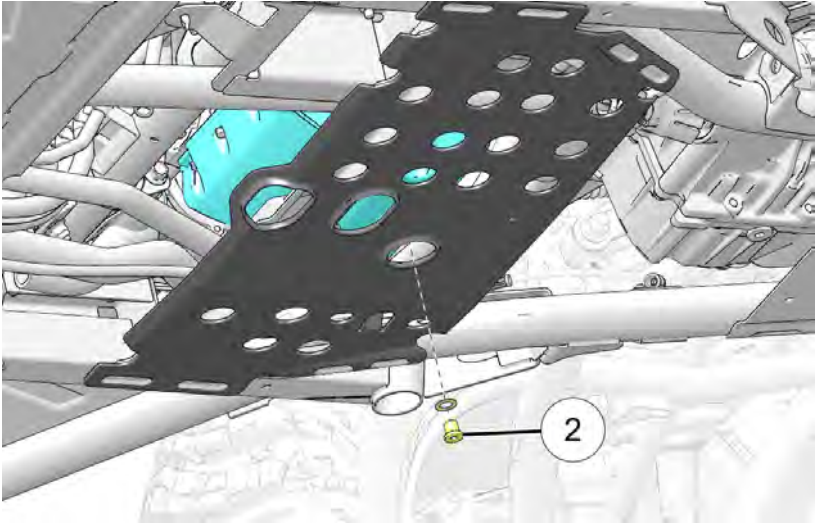

6. Using an extension, swivel, and oil filter wrench, turn the oil filter ③ counter-clockwise to remove it.

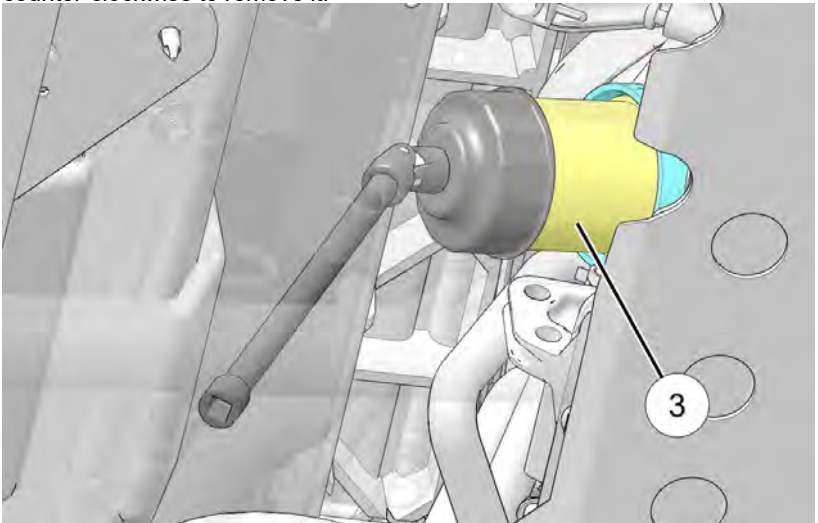

7. Using a clean dry cloth, clean the filter sealing surface on the engine crankcase.

## MAINTENANCE

---

- Lubricate the O-ring on the new oil filter with a film of fresh engine oil. Check to make sure the O-ring is in good condition. Install the oil filter.

### TORQUE

**Oil Filter Torque:**  
**Turn by hand until filter o-ring contacts sealing surface, then turn an additional 3/4 turn.**

- Replace the sealing washer on drain plug.

### NOTICE

The sealing surface on the drain plug should be clean and free of burrs, nicks or scratches.

- Reinstall the engine crankcase drain plug. Torque drain plug to specification.
- Remove oil fill cap. Fill engine with recommended engine oil.
- Verify the transmission is still in PARK.
- Start the engine and allow it to idle for 30 seconds.
- Stop the engine and inspect for oil leaks. Wait at least 15 seconds before removing the dipstick.
- Ensure oil level is within SAFE range on dipstick.
- Reinstall the skid plates.
- Dispose of used oil and filter properly.

## GEARCASES

### TRANSMISSION (MAIN GEARCASE)

Always check and change the transmission oil at the intervals outlined in the Polaris Maintenance Schedule. Refer to the Gearcase Specifications Chart for recommended lubricants, capacities and torque specifications. See page 165 for the part numbers of POLARIS products.

#### **OIL CHECK**

The fluid check/fill plug is located on the rear of the gearcase. Maintain the oil level even with the bottom of the plug hole threads.

1. Position the vehicle on a level surface.
2. Remove the fill plug ①.
3. Check the fluid level.
4. Add the recommended fluid to the bottom of the fill plug hole. Do not overfill.
5. Reinstall the fill plug. Torque to specification.



#### **OIL CHANGE**

The drain plug is located near the bottom of the gearcase.

1. Remove the fill plug ①.
2. Place a drain pan under the drain plug ②.
3. Remove the drain plug. Allow the fluid to drain completely.
4. Clean and reinstall the drain plug. Torque to specification.
5. Add the recommended fluid to the bottom of the fill plug hole. Do not overfill.
6. Reinstall the fill plug. Torque to specification.
7. Check for leaks. Discard used fluid properly.

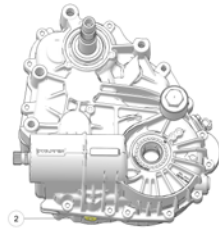

# MAINTENANCE

## FRONT GEARCASE

Always check and change the front gearcase oil at the intervals outlined in the Polaris Maintenance Schedule. Maintain the oil level even with the bottom thread of the fill plug hole. Refer to the Gearcase Specifications Chart for recommended lubricants, capacities and torque specifications. See page 165 for the part numbers of POLARIS products.

### OIL CHECK

The front gearcase fill plug is located on the right side of the front gearcase.

1. Position the vehicle on a level surface.
2. Place the transmission in PARK.
3. Remove the fill plug ①. Check the oil level.
4. Add the recommended oil as needed.
5. Reinstall the fill plug. Torque to specification.



### OIL CHANGE

1. Remove the fill plug.
2. Place a drain pan under the drain plug.
3. Remove the drain plug. Allow the oil to drain completely.
4. Clean and reinstall the drain plug. Torque to specification.
5. Add the recommended oil.
6. Reinstall the fill plug. Torque to specification.
7. Check for leaks. Discard of used oil properly.

## GEARCASE SPECIFICATION CHART

GEARCASE	LUBRICANT	CAPACITY	FILL PLUG TORQUE	DRAIN PLUG TORQUE
Main Gearcase (Transmission)	AGL Gearcase Lubricant & Transmission Fluid	52.4 oz. (1550 ml)	10-14 ft. lbs. (14-19 Nm)	10-14 ft. lbs. (14-19 Nm)
Front Gearcase	Demand Drive Fluid	10 – 11.83 Oz (300 – 350 ml)	8-30 ft. lbs. (11-40 Nm)	8-30 ft. lbs. (11-40 Nm)

## SPARK PLUGS

### SPARK PLUG RECOMMENDATIONS

Refer to the Specifications section for the recommended spark plug type for your vehicle. Always torque spark plugs to specification.

#### NOTICE

Using non-recommended spark plugs can result in serious engine damage. Always use POLARIS-recommended spark plugs or their equivalent.

### SPARK PLUG GAP / TORQUE

ELECTRODE GAP	PLUG TORQUE
0.7-0.8 mm	7 ft. lbs. (9.5 Nm)

### SPARK PLUG INSPECTION

Spark plug condition is indicative of engine operation. The spark plug firing end condition should be read after the engine is warmed up and the vehicle is driven at higher speeds. Immediately check the spark plug for correct color.

1. Remove the engine access panel from the cargo box. Remove the spark plug cap.

#### CAUTION

A hot exhaust system and engine can cause burns. Wear protective gloves when removing a spark plug for inspection.

2. Using the spark plug wrench provided in the tool kit, remove the plug by rotating it counter-clockwise.
3. Reverse the procedure for spark plug installation. Apply anti-seize compound to the spark plug threads.
4. Torque to specification.

### NORMAL PLUG

The normal insulator tip is gray, tan or light brown. There will be few combustion deposits. The electrodes are not burned or eroded. This indicates the proper type and heat range for the engine and the service.

The tip should not be white. A white insulator tip indicates overheating, caused by use of an improper spark plug or incorrect throttle body adjustments.

### ***WET FOULED PLUG***

The wet fouled insulator tip is black. A damp oil film covers the firing end. There may be a carbon layer over the entire nose. Generally, the electrodes are not worn. General causes of fouling are: incorrect spark plug type or heat range, excessive engine oil consumption or incorrect throttle body adjustments.

---

## COOLING SYSTEM

The engine coolant level is maintained by a remote pressurized tank system. The remote pressurized tank is connected to the radiator and provides a single pressure cap and fill point for the vehicle.

The pressure tank is designed to contain a volume of air above the coolant level. As coolant operating temperature increases the coolant level in the pressure tank will rise and push out air past the pressure cap. As the engine coolant temperature decreases the coolant level in the pressure tank will lower and draw air back into the tank through the pressure cap.

### TIP

Some coolant level drop on new vehicles is normal as the system is purging itself of trapped air. Observe coolant levels and maintain cold coolant level as recommended by adding coolant to the pressure tank.

### CAUTION

Escaping steam can cause burns. Never remove the pressure cap while the engine is warm or hot. Always allow the engine to cool before removing the pressure cap.

## ADDING OR CHANGING COOLANT

POLARIS recommends the use of POLARIS Antifreeze 50/50 Premix. This antifreeze is already premixed and ready to use. Do not dilute with water.

To ensure that the coolant maintains its ability to protect the engine, we recommend that the system be completely drained every five (5) years and fresh Antifreeze 50/50 Premix added.

Any time the cooling system has been drained for maintenance or repair, replace the coolant with fresh Antifreeze 50/50 Premix. If the pressure tank has run dry, fill as needed to bring the coolant level to within one inch of the cold fill mark.

## RADIATOR AND COOLING FAN

Always check and clean the screen and radiator fins at the intervals outlined in the Polaris Maintenance Schedule. Do not obstruct or deflect air flow through the radiator by installing unauthorized accessories in front of the radiator or behind the cooling fan. Interference with the radiator air flow can lead to overheating and consequent engine damage.

## MAINTENANCE

### NOTICE

Washing the vehicle with a high-pressure hose could damage the radiator fins and impair the radiator's effectiveness. Using a high-pressure system is not recommended.

## RADIATOR COOLANT LEVEL / CHANGING COOLANT

Always check and change the coolant at the intervals outlined in the Polaris Maintenance Schedule. Maintain the coolant level within 1 in (25.4mm) of the cold mark on the pressure tank (when the fluid is cool).

The changing coolant procedure is required only if the cooling system has been drained for maintenance and/or repair. Ensure vehicle is parked on a level surface before servicing.

1. Position the vehicle on a level surface.
2. Place the transmission in PARK.
3. Remove the drivers side rear panel ①. Pull up on the release tab, then slide the panel to the front of the vehicle. Pull out on the panel to remove.

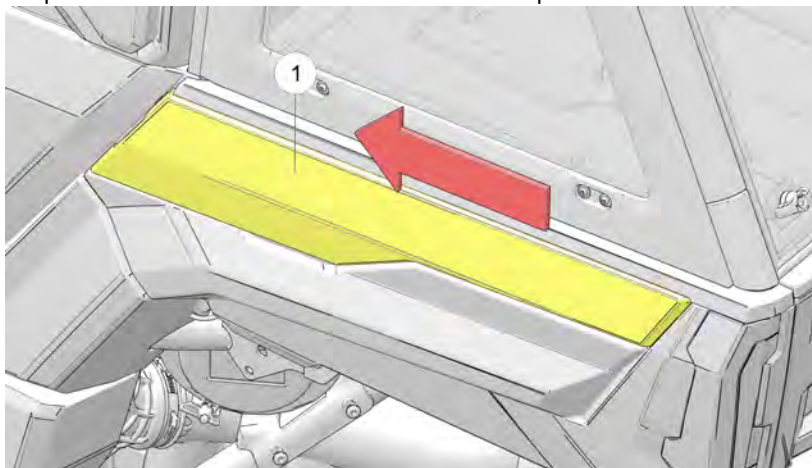



4. View the coolant level in the pressure tank ②.

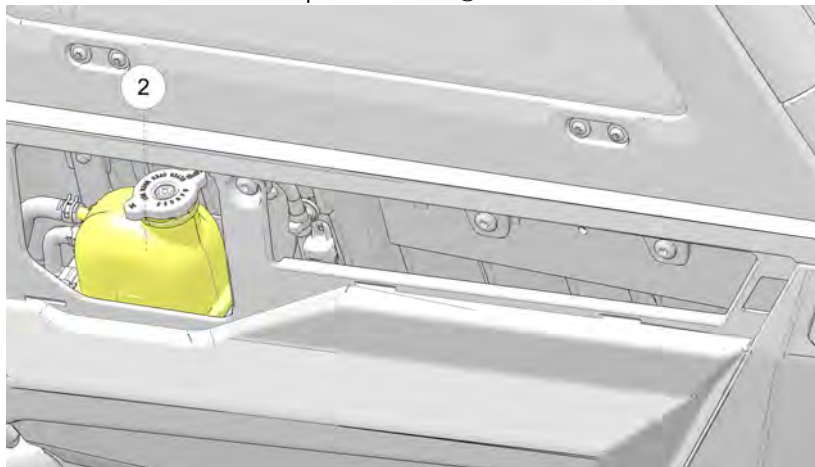

## ⚠ CAUTION

Escaping steam can cause burns. Never remove the pressure cap while the engine is warm or hot. Always allow the engine to cool before removing the pressure cap.

5. If the coolant level is below the safe operating range, coolant must be added to the pressure tank.

## NOTICE

Coolant can only be added through the pressure tank. There is no pressure cap on the radiator.

6. Use a funnel and slowly add coolant as needed.
7. Reinstall the pressure cap securely. Use of a non-standard pressure cap will not allow the system to function properly. Your POLARIS dealer, or other qualified person, can provide the correct replacement part.
8. Reinstall the driver's side rear panel. Place the panel into the slots on the rear panel, then push forward to lock.

## NOTICE

If coolant must be added often, or if the pressure tank runs completely dry, there may be a leak in the system. Your POLARIS dealer, or other qualified person, can inspect the cooling system.

# AIR CONDITIONING

### WARNING

Only licensed and certified professionals are allowed to check and maintain AC refrigerant levels. Your POLARIS dealer can assist.

## HVAC INTAKE FILTER CLEANING

The HVAC Intake filter is located below the hood.

1. Loosen the worm gear clamp that secures the filter. Remove the filter from the vehicle.
2. Clean the filter with low air pressure. Check for damage, replace if damaged.

## HVAC RECIRCULATION FILTER CLEANING

The HVAC Recirculation filter is located beneath the dash in the HVAC airbox.

1. Remove the two pushclips ① that retain the filter cover. Remove the cover

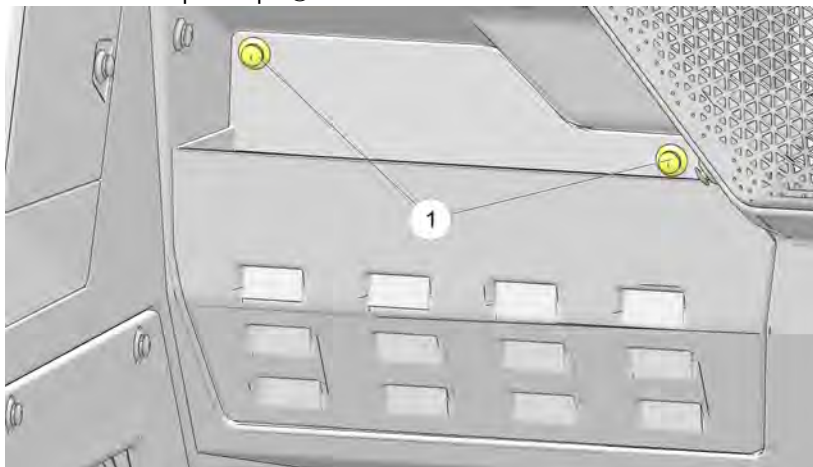

2. Unclip both sides of the filter to remove it from the housing. Pull the filter downwards, then away from the filter housing.
3. Clean the filter with low air pressure. If the filter is damaged, replace the filter.

## CONDENSER CLEANING

### NOTICE

Washing the vehicle with a high-pressure hose could damage the radiator fins and impair the radiator's effectiveness. Using a high-pressure system is not recommended.

The condenser should be cleaned at the correct service interval as outlined in the Polaris Maintenance Schedule. The condenser is located at the front of the vehicle, behind the front grille.

To clean the condenser, do the following:

1. Stop the machine on a flat level surface. Place the gear selector in PARK. Stop the engine and exit the vehicle.
2. Remove the hood. See page 58.
3. Use low pressure air or water to clean the condenser.
4. Reinstall the front grille and ensure it is snapped into place.

# POLARIS VARIABLE TRANSMISSION (PVT) SYSTEM

### WARNING

Failure to comply with the instructions in this warning can result in severe injury or death. Do not modify any component of the PVT system. Doing so may reduce its strength so that a failure may occur at a high speed. The PVT system has been precision balanced. Any modification will cause the system to be out of balance, creating vibration and additional loads on components.

The PVT system rotates at high speeds, creating large amounts of force on clutch components. As the owner, you have the following responsibilities for your own safety and the safety of others:

- Always follow all recommended maintenance procedures. Always look for and remove debris inside and around the clutch and vent system when replacing the belt.
- See your dealer or other qualified service person as outlined in the owner's manual.
- This PVT system is intended for use on POLARIS products only. Do not install it in any other product.
- Always make sure the PVT housing is securely in place during operation.

## BELT REPLACEMENT / DEBRIS REMOVAL

If a belt fails, always clean any debris from the duct and from the clutch and engine compartments when replacing the belt. Allow the vehicle to cool before performing this procedure.

### WARNING

Failure to remove ALL debris when replacing the belt could result in vehicle damage, loss of control and severe injury or death.

1. Position the vehicle on a flat, level surface.
2. Place the transmission in PARK.
3. Remove the engine access cover. Thoroughly clean all debris from the debris bracket  and from the engine compartment.

4. Loosen the air duct clamp ① on the bottom of the air filter housing.

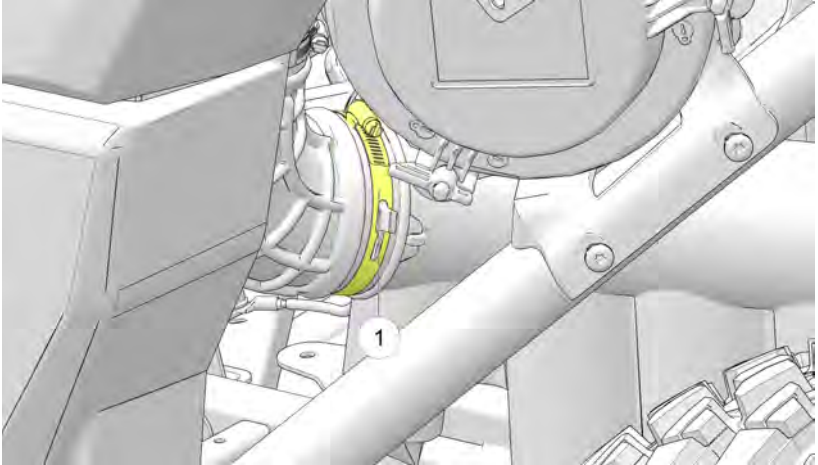

5. Loosen the air duct clamp ② on the drive belt cover. Remove the air duct hose from the vehicle.

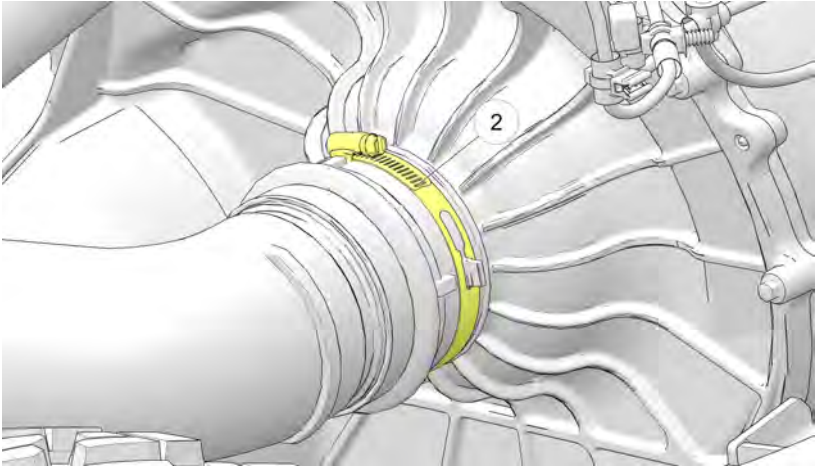

## MAINTENANCE

---

- Loosen all fourteen drive belt cover fasteners ③.

### NOTICE

Do not remove the fasteners from the drive belt cover.

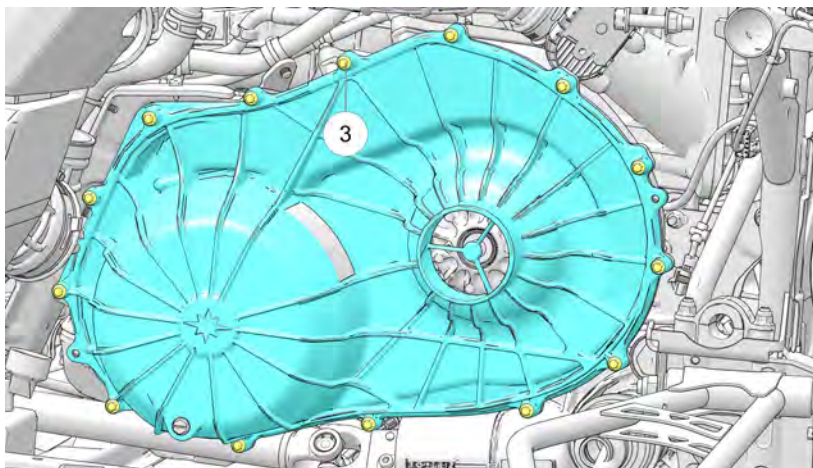

- Remove the drive belt cover ④ from the vehicle. Pivot the rear of the cover up to remove.

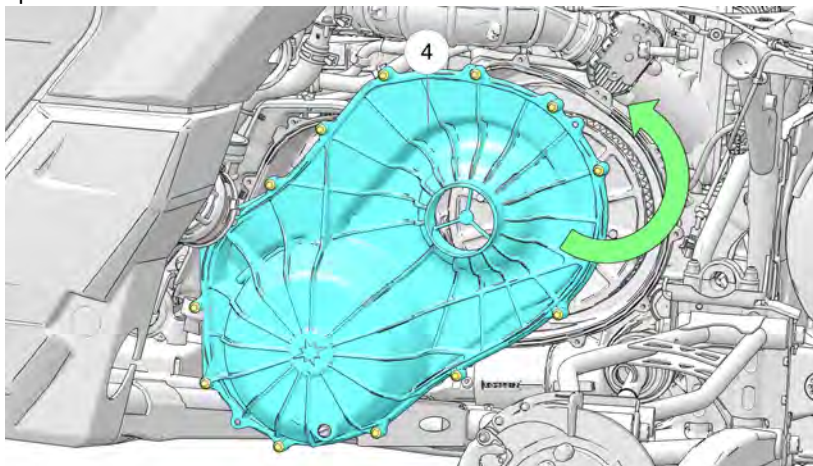

- Inspect the cover seal on the clutch housing for wear or damage. Replace if necessary.
- Mark or note the direction of the PVT drive belt. The belt must be installed in the same direction if the belt will be reinstalled.

10. Insert the clutch spreader tool into the threaded hole on the driven clutch. Turn the spreader tool clockwise to spread the clutch.

### NOTICE

If the tool does not readily turn, rotate the driven clutch one quarter of a turn counterclockwise. Repeat the above step.

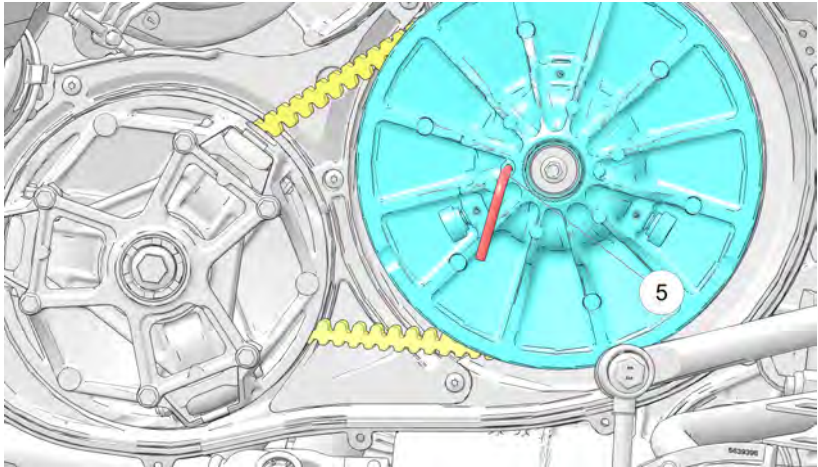

11. Remove the belt from the driven clutch.

### TIP

Removing the belt from the bottom of the driven clutch first can help provide additional clearance for belt removal.

12. Inspect the belt for any fraying, hour-glassing, loose cords, missing cogs, abrasions, burns, or damage. Replace if needed.
13. Clean the inside of the drive belt covers thoroughly and ensure that all debris from the air duct is removed.
14. Check for signs of damage to seals on the transmission and engine. If any seals appear to be damaged, your vehicle requires prompt service. Your POLARIS dealer can assist.

### TIP

Belt slip is responsible for creating excessive heat that destroys belts, wears clutch components and causes outer clutch covers to fail. Switch to low range while operating at slower speeds to extend the life of the PVT components (belt, cover, etc.).

## MAINTENANCE

---

15. Loop the new belt over the drive clutch, and begin to install it over the driven clutch sheave. Then, remove the clutch spreader tool from the driven clutch.
16. Rotate the driven clutch clockwise five to seven times to help seat the belt onto the sheaves.
17. Reinstall the drive belt cover. Torque the fasteners to specifications.
18. Reinstall the air duct to both the airbox and the drive belt cover. Torque the clamps to specifications.
19. Reinstall the engine access cover.

## PVT DRYING

There may be some instances when water is accidentally ingested into the PVT system. Use the following instructions to dry it out before operating.

1. Remove the clutch cover drain plug.
2. Allow the water to drain. Reinstall the drain plug.
3. Place the transmission in PARK. Apply the brakes.
4. Start the engine.
5. Apply varying throttle for 10-15 seconds to expel the moisture and air-dry the belt and clutches. Do not hold the throttle wide open for more than 10 seconds.
6. Allow the engine RPM to settle to idle speed. Apply the brakes. Shift the transmission to the lowest available range.
7. Test for belt slippage. If the belt slips, repeat the process.
8. Your vehicle requires service as soon as possible. Your POLARIS dealer, or other qualified person, can assist.

## VEHICLE IMMERSION

### WARNING

If your vehicle becomes immersed, major engine damage can result if the machine is not thoroughly inspected. Take the vehicle in for service before starting the engine. Your POLARIS dealer, or other qualified person, can provide this service.

If it's impossible to take your POLARIS vehicle to a dealer before starting it, follow the steps outlined below:



1. Move the vehicle to dry land, or at the very least, to water below the floorboard.
2. Dry any water present in the air box. Filter replacement is required if water is present.
3. Dry any water present in the intake manifold.
4. Remove the spark plugs. Turn the engine over several times using the electric start.
5. Dry the spark plugs and reinstall, or replace with new plugs.
6. Attempt to start the engine. If necessary, repeat the drying procedure.
7. Take the vehicle in for service as soon as possible, whether you succeed in starting it or not. Your POLARIS dealer, or other qualified person, can provide the required service.
8. If water has been ingested into the PVT follow the PVT Drying procedure.

## STEERING WHEEL INSPECTION

Check the steering wheel for specified freeplay and smooth operation at the intervals outlined in the Polaris Maintenance Schedule.

1. Position the vehicle on level ground.
2. Place a piece of tape or similar marking device on the steering wheel to mark the steering wheel position.
3. Lightly turn the steering wheel left and right.
4. Measure the distance that the tape or marking device moves WITHOUT moving the tires.
5. There should be 0.8-1.0 in (20-25 mm) of freeplay.
6. If there is excessive freeplay or strange noises, or the steering feels rough or “catchy,” have the steering system inspected by an authorized dealer.

## POWER STEERING UNIT

Frequently clean the areas around and on the power steering unit to allow proper cooling. Clean these areas ① thoroughly.

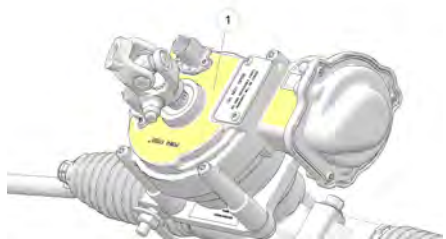

# FILTER SYSTEMS

## AIR FILTER

Always change the air filter at the intervals outlined in the Polaris Maintenance Schedule. Service the air filter more frequently if the vehicle is operated in wet conditions or at high throttle for extended periods.

1. Turn the airbox latches to the unlock position. Remove the cover.

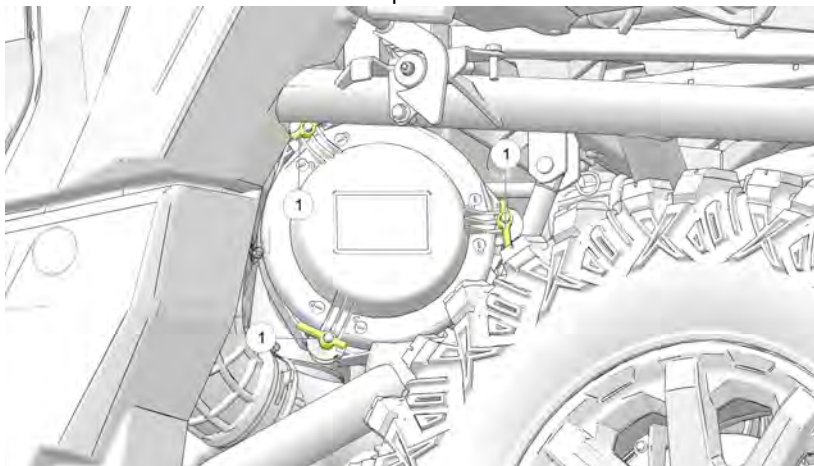

2. Remove the air filter.
3. Inspect the air box for oil or water deposits. Wipe away any deposits with a clean cloth.
4. Install a new filter if needed. Do not attempt to clean the air filter.

---

## SPARK ARRESTER

 **WARNING**

- Never operate the vehicle without the spark arrester.
- Remove any combustible materials from the area.

**Failure to heed the following warnings while servicing the spark arrester could result in serious injury or death.**

- Never run the engine in an enclosed area. Exhaust contains poisonous carbon monoxide gas that can cause loss of consciousness or death in a very short time.
- Do NOT perform service on the spark arrester while the system is HOT. Exhaust system temperatures can reach extreme temperatures. Allow components to cool sufficiently before proceeding.
- Do not stand behind or in front of the vehicle while purging the exhaust system.
- Never go under the vehicle while it is inclined.
- Wear eye protection and gloves while servicing.

Periodically clean the spark arrester to remove accumulated carbon.

1. Place the transmission in PARK.
2. Remove the arrester retaining bolt.
3. Remove the arrester from the end of the muffler.
4. Use a non-synthetic brush to clean the arrester screen. A synthetic brush may melt if components are warm. If necessary, blow debris from the screen with compressed air.
5. Inspect the screen for wear and damage. Replace a worn or damaged screen.
6. Reinstall the arrester.
7. Torque the bolt to 7.3-8.9 ft. lbs. (10–12 Nm).

## MAINTENANCE

---

### BRAKES

The front and rear brakes are hydraulic disc type brakes activated by the brake pedal.

#### WARNING

Do not perform maintenance immediately after the vehicle has been operated, as the brake system may become very hot. Serious burns could result from contact with hot brake components. Allow components to cool before proceeding. Always wear eye protection and gloves.

### BRAKE FLUID

Inspect the brake system routinely. Inspect the level of the brake fluid before each operation.

#### WARNING

After opening a bottle of brake fluid, always discard any unused portion. Never store or use a partial bottle. Brake fluid is hygroscopic, meaning it rapidly absorbs moisture from the air. The moisture causes the boiling temperature of the brake fluid to drop, which can lead to early brake fade and the possibility of accident or severe injury.

Change the brake fluid every two years and any time the fluid becomes contaminated, the fluid level is below the minimum, or if the type and brand of the fluid in the reservoir are unknown.

1. Position the vehicle on a level surface.
2. Place the transmission in PARK.
3. View the brake fluid level at the reservoir in the driver's side wheel well.
4. The level should be between the upper (MAX) and lower (MIN) level lines.
5. If the fluid level is lower than the upper level line, add brake fluid to the upper (MAX) line.
6. Apply the brake forcefully for a few seconds and check for fluid leakage around the fittings.

## BRAKE INSPECTION

### WARNING

Do not apply WD-40® or any petroleum product to brake discs. These types of products are flammable and may also reduce the friction between the brake pad and caliper.

1. Check the brake system for fluid leaks.
2. Check the brake pedal for excessive travel or a spongy feel.
3. Check the friction pads for wear, damage and looseness.
4. Check brake discs for signs of cracks, excessive corrosion, warping or other damage. Clean any grease using an approved brake cleaner or alcohol.
5. Inspect the brake disc spline and pad wear surface for excessive wear. Change pads when worn to 0.030" (0.762 mm).

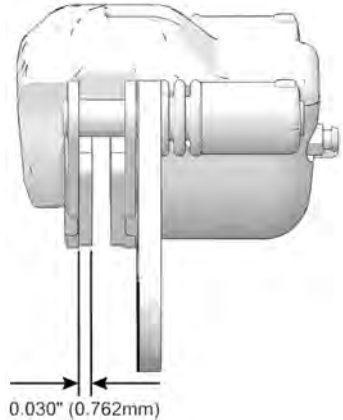

## SUSPENSION SETTINGS

### SHOCK SPRING ADJUSTMENT (PREMIUM MODELS)

### WARNING

Uneven adjustment may cause poor handling of the vehicle, which could result in an accident. Always adjust both the left and right spring preloads equally or have your POLARIS dealer perform the adjustments.



The front and rear shock absorber springs are adjustable to increase or decrease spring tension. Rotate the adjuster ① either clockwise or counter-clockwise to make adjustments.

Always apply the same adjustment setting to *all four wheels*.

## MAINTENANCE

### FRONT/REAR SPRING PRELOAD

The front and rear suspensions are preload adjustable. The suspensions are set to the factory preload as shown below. The factory setting is appropriate for nearly all riding conditions.

If desired, the suspension may be adjusted to maintain vehicle clearance height when carrying loads. *Always heed the following rules if you make adjustments to this suspension.*

- Always return the suspension to the factory preload after the load is removed from the vehicle. The increased suspension height will negatively impact vehicle stability when operating without a load.
- Always apply the same adjustment setting to *all four wheels*.
- Do not increase the spring preload by more than one inch (25.4 mm) over the factory setting.

FACTORY PRELOAD	2 PASSENGER ULTIMATE	CREW ULTIMATE/ 2 PASSENGER NORTHSTAR	CREW NORTHSTAR
Front	2.375 inches (60.33 mm)	1.127 inches (28.63 mm)	0.377 inches (9.58 mm)
Rear	0.765 inches (19.43 mm)	0.765 inches (19.43 mm)	0.00 inches (0 mm)

Your POLARIS dealer, or other qualified person, can provide the tool required to make suspension adjustments.

1. Elevate the vehicle to allow the suspension to fully extend.
2. Turn the preload nut to the left (1) to increase preload for a stiffer ride. Turn the preload nut to the right (2) to decrease preload for a softer ride.

#### WARNING

Uneven adjustment may cause poor handling of the vehicle, which could result in an accident. Always adjust both the left and right spring preloads equally. Your POLARIS dealer, or other qualified person, can assist.

### FRONT/REAR SHOCK COMPRESSION

The compression damping adjustment is located on the shock 'Piggyback' reservoir of each shock. Damping adjustments can be made without using any tools.

Turn the adjuster knob clockwise to increase compression damping. Turn the adjuster knob ① counter-clockwise to decrease compression damping.



### FACTORY COMPRESSION SETTINGS

Front Shock	Center Position
Rear Shock	Center Position

### CAUTION

Always adjust the shocks when the engine is cold. Components may become hot after vehicle use, and may cause injuries.

## TIRES

### WARNING

Operating your vehicle with worn tires will increase the possibility of skidding, loss of control and an accident, which could result in serious injury or death.

Always replace tires when the tread depth measures 1/8 in (3 mm) or less.

Improper tire inflation or the use of non-standard size or type of tires may adversely affect vehicle handling, which could result in vehicle damage or personal injury. Always maintain proper tire pressure. Always use POLARIS approved size and type of tires for this vehicle when replacing tires.

## MAINTENANCE

### TIRE TREAD DEPTH

Always replace tires when tread depth is worn to 3 mm (1/8") or less.

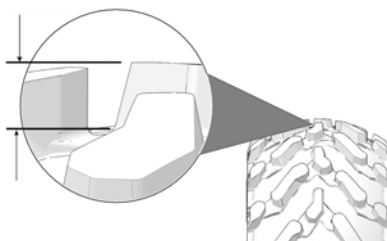

### LUG NUT TORQUE SPECIFICATIONS

Inspect the following items occasionally for tightness, and if they've been loosened for maintenance service. Do not lubricate the stud or the lug nut.

NUT TYPE	LOCATION	NUT TORQUE
Lug Nut (Aluminum Wheels) 	Front and Rear	120 ft-lbs (163 Nm)

### WHEEL REMOVAL

1. Position the vehicle on a level surface.
2. Place the transmission in PARK. Stop the engine.
3. Loosen the lug nuts slightly.
4. Elevate the side of the vehicle by placing a suitable stand under the frame.
5. Remove the lug nuts. Remove the wheel.

### WHEEL INSTALLATION

#### WARNING

Improperly installed wheels can adversely affect tire wear and vehicle handling, which can result in serious injury or death. Always ensure that all lug nuts are torqued to specification. Do not service axle nuts that have a cotter pin installed. Your dealer can assist.



1. Place the transmission in PARK.
2. Place the wheel on the hub with the valve stem toward the outside and rotation arrows on the tire pointing toward forward rotation.
3. Attach the lug nuts and finger-tighten.
4. Carefully lower the vehicle to the ground.
5. Torque the lug nuts to specification.

## FUSES (PREMIUM AND ULTIMATE MODELS ONLY)

If the engine stops or will not start, or if you experience other electrical failures, a fuse may need replacement. Locate and correct any short circuits that may have caused the blown fuse, then replace the fuse. Raise the center console lid and remove the storage bin to access the fuse center. Spare fuses can be found in the tool kit.

If you suspect that a fuse or relay may not be working properly, please see your dealer, or other qualified person.

### MAIN FUSE BOX

FUSE SIZE	FEATURE SUPPORTED
7.5 A	Unswitched ECU
10 A	Fuel
40 A	EPS
15 A	Chassis 1
10 A	EFI
5 A	Key
7.5 A	Accy Lt
10 A	Accy Power
20 A	Accy
10 A	Chassis 2
7.5 A	Coil
20 A	Audio Amp
15 A	Audio

## MAINTENANCE

FUSE SIZE	FEATURE SUPPORTED
30 A	Sub
10 A	Charge

### SECONDARY FUSE BOX

FUSE SIZE	FEATURE SUPPORTED
10 A	HB Lights
15 A	Lights
10 A	LB Lights
25A	Fan CB

## FUSES (NORTHSTAR MODELS ONLY)

If the engine stops or will not start, or if you experience other electrical failures, a fuse may need replacement. Locate and correct any short circuits that may have caused the blown fuse, then replace the fuse. Raise the center console lid and remove the storage bin to access the fuse center. Spare fuses can be found in the tool kit.

If you suspect that a fuse or relay may not be working properly, please see your dealer, or other qualified person.

### MAIN FUSE BOX

FUSE SIZE	FEATURE SUPPORTED
7.5 A	Unswitched ECU
10 A	Fuel
15 A	Chassis 1
40 A	EPS
25 A	HVAC
30 A	Engine Fan
10 A	EFI
5 A	Key
7.5 A	Accy Lt

FUSE SIZE	FEATURE SUPPORTED
10 A	Accy Pwr
20 A	Accy
10 A	Chassis 2
25 A	Window 2
7.5 A	Coil
15 A	Audio
10 A	Charge
20 A	Audio Amp
30 A	Sub
25 A	Window 1

**SECONDARY FUSE BOX**

FUSE SIZE	FEATURE SUPPORTED
10 A	HB Lights
10 A	Clutch
10 A	Wiper
15 A	Lights
10 A	LB Lights
5 A	HVAC CTRL

### LIGHTS

Poor lighting can result in reduced visibility when driving. Headlight and taillight lenses become dirty during normal operation. Clean lights frequently and replace burned out lamps promptly. Do not operate this vehicle at night or in low light conditions until the headlight is replaced. Always make sure lights are adjusted properly for best visibility.

### HEADLIGHT REPLACEMENT

If a headlight becomes damaged or inoperable, the entire headlight assembly must be replaced. Do not operate this vehicle at night or in low light conditions until the headlight is replaced. Always make sure lights are adjusted properly for best visibility.

## HEADLIGHT BEAM ADJUSTMENT

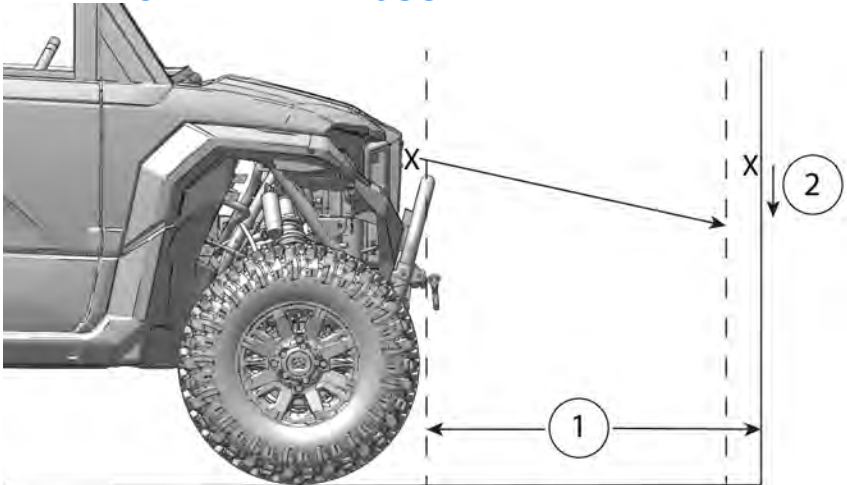

1. Place the vehicle on a level surface with the headlight approximately 25 ft. (7.6 m) ① from a wall.
2. Place the transmission in PARK.
3. Measure the distance from the floor to the center of the headlight and make a mark on the wall at the same height ②.
4. Apply the brakes. Start the engine. Turn on the headlights.
5. Observe the headlight aim. The most intense part of the headlight beam should be aimed 8" (20 cm) below the mark placed on the wall. Include the weight of a rider on the seat while performing this step.
6. If a headlight needs adjustment, locate the adjustment screw at the back of the headlight.
7. Loosen the screw. Adjust the headlight, then tighten the screw.
8. Repeat steps 5-7 until the lamp is properly adjusted.

## BATTERY

### WARNING

Improperly connecting or disconnecting battery cables can result in an explosion and cause serious injury or death. When removing the battery, always disconnect the negative (black) cable first. When reinstalling the battery, always connect the negative (black) cable last.

## MAINTENANCE

---

Your vehicle has a low-maintenance battery. Always keep battery terminals and connections free of corrosion. If cleaning is necessary, remove the corrosion with a stiff wire brush. Wash with a solution of one tablespoon baking soda and one cup water. Rinse well with tap water and dry off with clean shop towels. Coat the terminals with dielectric grease or petroleum jelly.

### BATTERY REMOVAL

1. Remove the driver's side seat. See the seat removal/ installation section.
2. Remove the access panel by turning the latch located in the front of the panel.

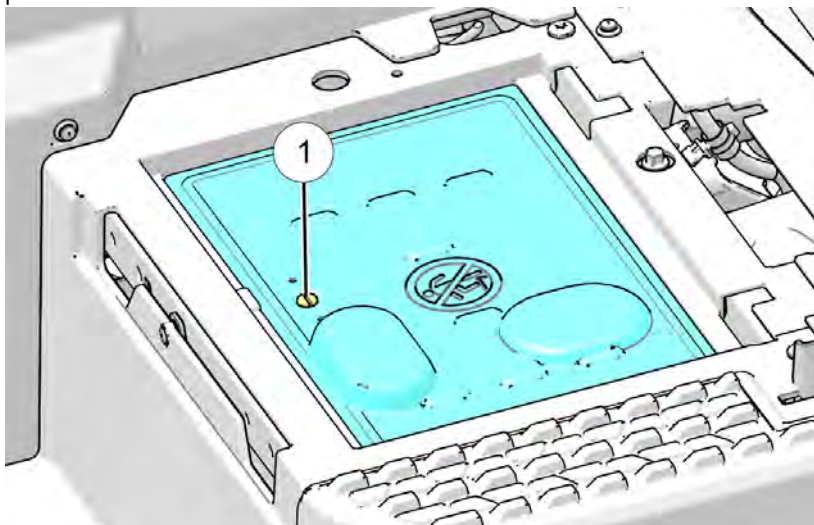

3. Disconnect the black (negative) battery cable ② first.

**⚠ CAUTION**

To reduce the chance of sparks: Whenever removing the battery, disconnect the black (negative) cable first. When reinstalling the battery, install the black (negative) cable last.

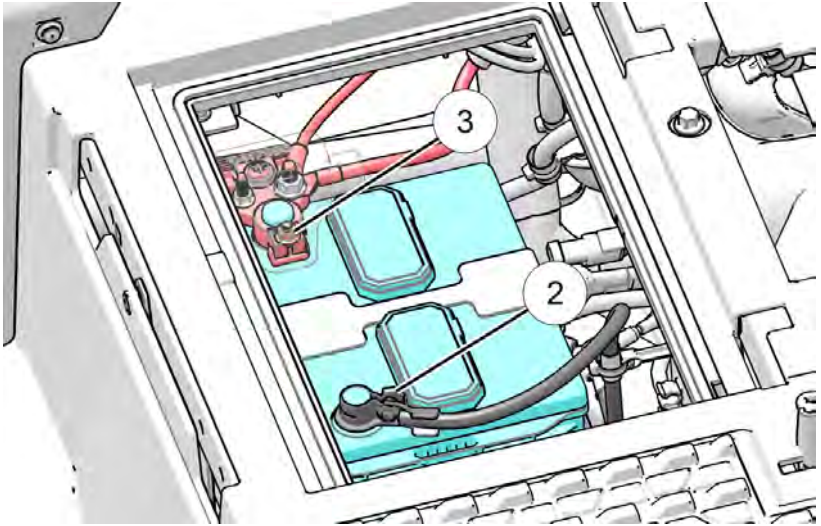

4. Disconnect the red (positive) battery cable ③ last.

## MAINTENANCE

---

5. Remove the battery hold-down strap by removing the fastener ④securing the hold-down strap.

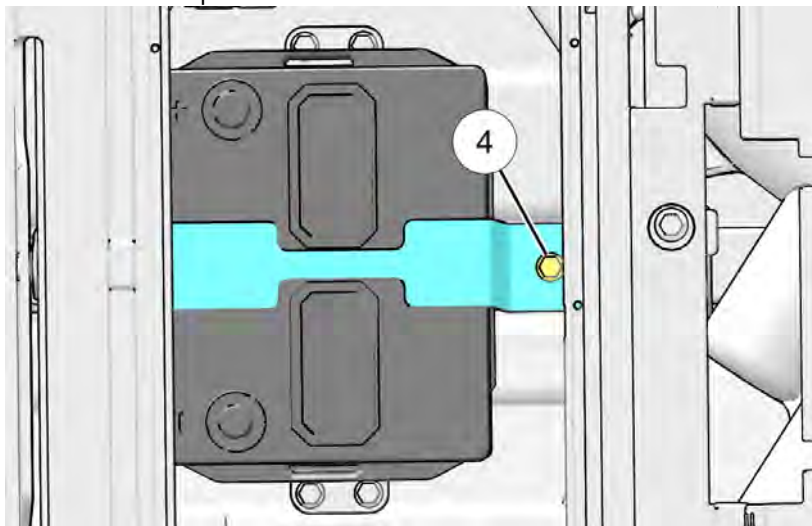

6. Lift the battery out of the vehicle.

## BATTERY INSTALLATION

Using a new battery that has not been fully charged can damage the battery and result in a shorter life. It can also hinder vehicle performance. Follow the battery charging instructions in the AGM Battery Maintenance and Charging section before installing the battery.

1. Ensure that the battery is fully charged.
2. Place the battery in the battery holder.
3. Coat the terminals with dielectric grease or petroleum jelly.
4. Secure the battery hold-down strap.
5. Connect and tighten the red (positive) cable first.
6. Connect and tighten the black (negative) cable last.
7. Verify that cables are properly routed.



## BATTERY MAINTENANCE AND CHARGING

 **WARNING**

An overheated battery may explode, causing severe injury or death. Always watch charging times carefully. Stop charging if the battery becomes very warm to the touch. Allow it to cool before resuming charging.

The sealed battery is already filled with electrolyte and has been sealed and *fully charged* at the factory. *Never* pry the sealing strip off or add any other fluid to this battery.

The single most important thing about maintaining a sealed battery is to keep it fully charged. Check the battery voltage with a voltmeter or multimeter. A fully charged battery will register 12.8 V or higher. If the voltage falls below 12.5V, charge it immediately, or the battery runs the risk of sulfation and reduced battery life.

If you do not drive the vehicle for more than TWO WEEKS, Polaris recommends using a BatteryMINDER® 2012 AGM - 2 AMP charger, which can be ordered through your dealer.

Polaris provides a charging accessory with your vehicle that allows easy connection to the battery through the vehicle trickle charge port, located on the front grille. During charging, place the charger outside of the vehicle and protect it from moisture.

If you plan to store the vehicle for THREE MONTHS or longer, remove the battery from the vehicle, then store the battery in a cool and dry location. Continue to maintain the battery with the BatteryMINDER® 2012 AGM - 2 AMP charger.

When using an automatic charger other than a BatteryMINDER® 2012-AGM - 2 AMP charger, refer to the charger manufacturer's instructions for recharging.

If using a **constant current charger** (instead of BatteryMINDER® 2012 AGM - 2 AMP charger), use the guidelines below. Always verify battery condition before and 1-2 hours after the end of charging.

STATE OF CHARGE	VOLTAGE (DC)	ACTION	CHARGE TIME*
100%	12.8-13.0 volts	None, check monthly	None required
75%-100%	12.6-12.8 volts	May need slight charge, if no charge given, check in 2 weeks	3-6 hours
50%-75%	12.3-12.6 volts	Needs charge	5-11 hours
25%-50%	12.0-12.3 volts	Needs charge	At least 13 hours

## MAINTENANCE

<b>STATE OF CHARGE</b>	<b>VOLTAGE (DC)</b>	<b>ACTION</b>	<b>CHARGE TIME*</b>
0%-25%	12.0 volts or less	Needs charge	At least 20 hours
* Using AGM specific charger at standard amps specified on top of battery			



# CLEANING AND STORAGE

## WASHING THE VEHICLE

Keeping your POLARIS vehicle clean will not only improve its appearance but it can also extend the life of various components.

Water in the PVT system could cause the drive belt to become wet and slip in the clutches. Always avoid spraying water directly toward any intake pre-filters. If water does enter the PVT intake, follow the procedure on *PVT Drying*.

High water pressure may damage radiator fins and impair a radiator's effectiveness. High pressure may also damage other vehicle components.

Certain products, including insect repellents and chemicals, will damage plastic surfaces. Do not allow these types of products to contact the vehicle.

The best and safest way to clean your POLARIS vehicle is with a garden hose and a pail of mild soap and water.

1. Use a professional-type washing cloth, cleaning the upper body first and the lower parts last.
2. Rinse with clean water frequently.
3. Dry surfaces with a chamois to prevent water spots.

## WASHING TIPS

- Avoid the use of harsh cleaners, which can damage the finish.
- Do not use medium to heavy duty compounds on the finish.
- Always use clean cloths and pads for cleaning and polishing. Old or reused cloths and pads may contain dirt particles that will scratch the finish.
- Do not use high-speed polishers/buffers on body panels, as damage or color fading may occur.
- Do not spray water directly into the intake ducts.

If a high pressure water system is used for cleaning, exercise extreme caution. The maximum pressure should not exceed 3000 PSI, 2.5 GPM with a 40° pressure washer nozzle. Make sure to keep the pressure washer nozzle 2 ft (.6 m) from the vehicle away from the surface being cleaned. The water may damage components and could remove paint and labels. Avoid directing the water stream at the following items:

- Wheel bearings
- Radiator
- Transmission seals
- Brakes
- Cab and body panels
- Labels and decals
- Electrical components and wiring
- Air intake components
- Throttle and shift cables and controls
- Seat Belts
- Seats

### WARNING

Spilled oil left on engine components or in the engine area may pose a fire hazard. Use shop rags to clean any spilled oil. If needed, use a non-flammable solvent on the rag to aid in the cleaning process. Do not use any device such as a pressurized water or air as this may disperse the oil onto engine components and could pose a fire hazard.

### WARNING

Clean seat belts with warm water. Avoid damaging seat belts:

- Do not use bleach, dye or household detergents.
- Never use lubricant on any seat belt component.
- Do not use a pressure washer to clean the seat belts.

If warning and safety labels are damaged, contact your POLARIS dealer for free replacement.

Grease all zerk fittings (if applicable) immediately after washing. Allow the engine to run for a while to evaporate any water that may have entered the engine or exhaust system.

## POLISHING THE VEHICLE

POLARIS recommends the use of common household aerosol furniture polish for polishing the finish on your POLARIS vehicle. Follow the instructions on the container.

### ***POLISHING TIPS***

- Avoid the use of automotive products, some of which can scratch the finish of your vehicle.
- Always use clean cloths and pads for cleaning and polishing. Old or reused cloths and pads may contain dirt particles that will scratch the finish.

## MAINTENANCE

---

### STORAGE TIPS

#### NOTICE

Starting the engine during the storage period will disturb the protective film created by fogging and damage could occur. Never start the engine during the storage period.

### **CLEAN THE EXTERIOR**

Make any necessary repairs and clean the vehicle as recommended.

### **STABILIZE THE FUEL**

1. Fill the fuel tank.
2. Add POLARIS Carbon Clean Fuel Treatment or POLARIS Fuel Stabilizer or equivalent fuel treatments or stabilizers. Follow the instructions on the container for the recommended amount. Carbon Clean removes water from fuel systems, stabilizes fuel and removes carbon deposits from pistons, rings, valves and exhaust systems.
3. Allow the engine to run for 15-20 minutes to allow the stabilizer to disperse through the entire fuel delivery system.

### **OIL AND FILTER**

Change the oil and filter. See the Engine Oil section.

### **AIR FILTER / AIR BOX**

Replace the air filter. See Maintenance Chapter. Clean the air box.

### **INSPECT AND LUBRICATE**

Inspect all cables and lubricate all areas of the vehicle as recommended in the Polaris Maintenance Schedule.

### **BATTERY MAINTENANCE**

See the Battery Storage section and Battery Charging section for storage and charging procedures.

## **FOG THE ENGINE**

1. Treat the fuel system with POLARIS Carbon Clean or other equivalent fuel treatment. Follow the instructions on the container. Start the engine. Allow it to idle for several minutes so the Carbon Clean reaches the injectors. Stop the engine.
2. Remove the spark plugs and add 1–1.5 oz. (29.5–44 cc.) of engine oil. To access the plug holes, use a section of clear 6 mm (1/4") hose and a small plastic squeeze bottle filled with the pre-measured amount of oil. *Do this carefully! If you miss the plug holes, oil will drain from the spark plug cavities into the hole at the front of the cylinder head, and appear to be an oil leak.*
3. Reinstall the spark plugs. Torque to specification.
4. Apply dielectric grease to the inside of each spark plug cap. *Do not reinstall the cap onto the plug at this step.*
5. Turn the engine over several times. Oil will be forced in and around the piston rings and ring lands, coating the cylinder with a protective film of fresh oil.
6. Reinstall the spark plug caps.
7. If POLARIS fuel system additive is not used, fuel tank, fuel lines, and injectors should be completely drained of gasoline.

## **STORAGE AREA / COVERS**

Be sure the storage area is well ventilated. Cover the vehicle with a genuine POLARIS cover or similar that allows for adequate airflow. Do not use plastic or coated material, as these materials do not allow enough ventilation to prevent condensation and may promote corrosion and oxidation.

## **FLUID LEVELS**

Inspect the fluid levels. Add or change fluids as recommended in the Polaris Maintenance Schedule.

- Demand drive fluid (front gearcase)
- Rear gearcase fluid (if equipped)
- Transmission fluid
- Brake fluid (change every two years and any time the fluid looks dark or contaminated)
- Coolant (test strength/fill)

## MAINTENANCE

---

### REMOVAL FROM STORAGE



Engine exhaust contains poisonous carbon monoxide and can cause loss of consciousness or death. Never run an engine in an enclosed area.

1. Check the battery electrolyte level and charge the battery if necessary. Install it in the vehicle. Make sure the battery vent hose is routed properly and that it's not pinched or restricted in any way.
2. Make sure spark plugs are tight.
3. Fill the fuel tank with fuel.
4. Check all the points listed in the Daily Pre-Ride Inspection. *Tightness of the bolts, nuts and other fasteners should be checked by an authorized dealer or other qualified service facility.*
5. Lubricate at the intervals outlined in the Polaris Maintenance Schedule.

### TOWING THE POLARIS XPEDITION

Towing this vehicle is not recommended. Always transport the vehicle on a trailer or flatbed with all four wheels off the ground. See the Transporting the POLARIS XPEDITION section for details.

If towing a disabled vehicle is unavoidable, place the disabled vehicle's transmission in neutral. Tow the shortest distance possible. Do not operate faster than 10 MPH (16 km/h).

### TRANSPORTING THE POLARIS XPEDITION

Follow these procedures when transporting the vehicle.

1. Place the transmission in PARK. Stop the engine.
2. Slowly release the brake pedal and make sure the transmission is in PARK before exiting the vehicle.
3. Remove the key to prevent loss during transporting.



4. Secure the fuel cap, hood, doors, and cargo box. Ensure that the seats are attached correctly and are not loose.

### WARNING

Cargo and other loose vehicle parts may fly off while transporting this vehicle. Secure or remove all cargo, and inspect the unit for loose parts prior to transport.

When transporting vehicle in non-enclosed trailer, vehicle must **FACE FORWARD**. Windshield and all windows, doors, and rear liftgate (if equipped) must be **FULLY CLOSED** and **LATCHED**. Failure to comply may allow airflow, vibration, or other factors to separate the windshield, doors, roof, or rear liftgate (if equipped) from vehicle and cause an accident, resulting in serious injury or death.

5. Always tie the frame ① of the POLARIS vehicle to the transporting unit securely with suitable straps or rope. Do not attach tie straps to the front A-arm bolt pockets.

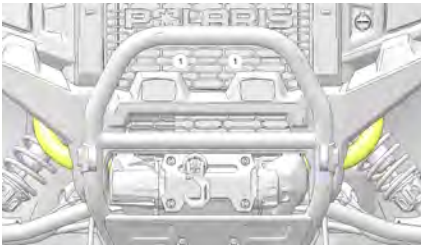



## SPECIFICATIONS

## POLARIS XPEDITION ADV PREMIUM

Maximum Weight Capacity (including operator, passenger, cargo, non-factory installed accessories)	1030 lbs. (467 kg)
Dry Weight	2083 lbs. (945 kg)
GVW (Gross Vehicle Weight)	3234 lbs. (1467 kg)
Fuel Capacity	12.5 gal. (47.3 L)
Engine Oil Capacity	2.5 qts. (2.4 L)
Coolant Capacity	7.1 qts. (6.7 L)
Towing Capacity	2000 lbs. (907 kg)
Hitch Tongue Capacity	200 lbs. (91 kg)
Max. Cargo Box Load	600 lbs. (272 kg)
Overall Length	122 in. (311 cm)
Overall Width	64 in. (163 cm)
Overall Height	75 in. (190 cm) (Without Roof Rack)
Wheelbase	88 in. (222 cm)
Cargo Box Dimensions (Inside)	36.2 x 47.25 x 13.5 in (92 x 120 x 34.3 cm)
Ground Clearance	13.5 in (34 cm)
Min. Turning Radius	199.2 in. (506 cm)
Engine	4-Stroke DOHC Twin Cylinder
Displacement	999 cc
Bore x Stroke	93 mm x 73.5 mm
Stator Output	660 W @ 3000 RPM
Compression Ratio	12.5:1
Starting System	Electric
Fuel System	Electronic fuel injection
Ignition System	Electronic
Spark Plug / Gap	MR7F / 0.7-0.8 mm

## SPECIFICATIONS

Front Suspension	Independent Double A-arm w/14 in. (35.5 cm) of travel
Rear Suspension	Independent Double A-arm w/15 in. (38.1 cm) of travel
Lubrication System	Wet Sump
Driving System Type	Automatic POLARIS Variable Transmission
Shift Type	Single Lever Dual Range (P/R/N/L/H)
Transmission Gear Ratio - High	Front 4.93:1 / Rear 14.73:1
Transmission Gear Ratio - Low	Front 10.92:1 / Rear 32.65:1
Transmission Gear Ratio - Reverse	Front 10.37:1 / Rear 31.01:1
Front Drive Ratio	3.08:1
Tire Size - Front	30x10R15 ProArmor Crawler XP
Tire Size - Rear	30x11R15 ProArmor Crawler XP
Tire Pressure - Front	14 psi (97 kPa)
Tire Pressure - Rear	18 psi (124 kPa)
Brakes, Front/Rear	Foot Activated, 4-wheel hydraulic disc
Hood Headlight	L.E.D.
Taillights	L.E.D.
Brake Light	L.E.D.
Instrument Cluster	Analog and LCD
Auxiliary DC Outlet	12V

## POLARIS XPEDITION ADV ULTIMATE

Maximum Weight Capacity (including operator, passenger, cargo, non-factory installed accessories)	1030 lbs. (467 kg)
Dry Weight	2128 lbs. (965 kg)
GVW (Gross Vehicle Weight)	3279 lbs. (1487 kg)
Fuel Capacity	12.5 gal. (47.3 L)
Engine Oil Capacity	2.5 qts. (2.4 L)
Coolant Capacity	7.1 qts. (6.7 L)

## SPECIFICATIONS

Towing Capacity	2000 lbs. (907 kg)
Hitch Tongue Capacity	200 lbs. (91 kg)
Max. Cargo Box Load	600 lbs. (272 kg)
Overall Length	122 in. (311 cm)
Overall Width	64 in. (163 cm)
Overall Height	75 in. (190 cm) (Without Roof Rack)
Wheelbase	88 in. (222 cm)
Cargo Box Dimensions (Inside)	36.2 x 47.25 x 13.5 in (92 x 120 x 34.3 cm)
Ground Clearance	13.5 in. (34 cm)
Min. Turning Radius	199.2 in. (506 cm)
Engine	4-Stroke DOHC Twin Cylinder
Displacement	999 cc
Bore x Stroke	93 mm x 73.5 mm
Stator Output	900 W @ 3000 RPM
Compression Ratio	10.5:1
Starting System	Electric
Fuel System	Electronic fuel injection
Ignition System	Electronic
Spark Plug / Gap	MR7F / 0.7-0.8 mm
Front Suspension	Independent Double A-arm w/14 in. (35.6 cm) of travel
Rear Suspension	Independent Double A-arm w/15 in. (38.1 cm) of travel
Lubrication System	Wet Sump
Driving System Type	Automatic POLARIS Variable Transmission
Shift Type	Single Lever Dual Range (P/R/N/L/H)
Transmission Gear Ratio - High	Front 4.93:1 / Rear 14.73:1
Transmission Gear Ratio - Low	Front 10.92:1 / Rear 32.65:1
Transmission Gear Ratio - Reverse	Front 10.37:1 / Rear 31.01:1
Front Drive Ratio	3.08:1

## SPECIFICATIONS

Tire Size - Front	30x10R15 ProArmor Crawler XP
Tire Size - Rear	30x11R15 ProArmor Crawler XP
Tire Pressure - Front	14 psi (97 kPa)
Tire Pressure - Rear	18 psi (124 kPa)
Brakes, Front/Rear	Foot Activated, 4-wheel hydraulic disc
Hood Headlight	L.E.D.
Taillights	L.E.D.
Brake Light	L.E.D.
Instrument Cluster	Analog and LCD
Auxiliary DC Outlet	12V

## POLARIS XPEdition ADV NORTHSTAR

Maximum Weight Capacity (including operator, passenger, cargo, non-factory installed accessories)	1030 lbs. (467 kg)
Dry Weight	2391 lbs. (1084 kg)
GVW (Gross Vehicle Weight)	3542 lbs. (1606 kg)
Fuel Capacity	12.5 gal. (47.3 L)
Engine Oil Capacity	2.5 qts. (2.4 L)
Coolant Capacity	9.3 qts. (8.8 L)
Towing Capacity	2000 lbs. (907 kg)
Hitch Tongue Capacity	200 lbs. (91 kg)
Max. Cargo Box Load	600 lbs. (272 kg)
Overall Length	122 in. (311 cm)
Overall Width	64 in. (163 cm)
Overall Height	75 in. (190 cm) (Without Roof Rack)
Wheelbase	88 in. (222 cm)
Cargo Box Dimensions (Inside)	36.2 x 47.25 x 13.5 in (92 x 120 x 34.3 cm)
Ground Clearance	13.5 in. (34 cm)
Min. Turning Radius	199.2 in. (506 cm)

## SPECIFICATIONS

Engine	4-Stroke DOHC Twin Cylinder
Displacement	999 cc
Bore x Stroke	93 mm x 73.5 mm
Alternator Output	1850 W (140A) @ 3000 RPM
Compression Ratio	10.5:1
Starting System	Electric
Fuel System	Electronic fuel injection
Ignition System	Electronic
Spark Plug / Gap	MR7F / 0.7-0.8 mm
Front Suspension	Independent Double A-arm w/14 in. (35.6 cm) of travel
Rear Suspension	Independent Double A-arm w/15 in. (38.1 cm) of travel
Lubrication System	Wet Sump
Driving System Type	Automatic POLARIS Variable Transmission
Shift Type	Single Lever Dual Range (P/R/N/L/H)
Transmission Gear Ratio - High	Front 4.93:1 / Rear 14.73:1
Transmission Gear Ratio - Low	Front 10.92:1 / Rear 32.65:1
Transmission Gear Ratio - Reverse	Front 10.37:1 / Rear 31.01:1
Front Drive Ratio	3.08:1
Tire Size - Front	30x10R15 ProArmor Crawler XP
Tire Size - Rear	30x11R15 ProArmor Crawler XP
Tire Pressure - Front	16 psi (110 kPa)
Tire Pressure - Rear	22 psi (152 kPa)
Brakes, Front/Rear	Foot Activated, 4-wheel hydraulic disc
Hood Headlight	L.E.D.
Taillights	L.E.D.
Brake Light	L.E.D.
Instrument Cluster	Analog and LCD
Auxiliary DC Outlet	12V

## SPECIFICATIONS

### POLARIS XPEDITION ADV 5 PREMIUM

Maximum Weight Capacity (including operator, passenger, cargo, non-factory installed accessories)	1160 lbs. (527 kg)
Dry Weight	2417 lbs. (1096 kg)
GVW (Gross Vehicle Weight)	3703 lbs. (1679 kg)
Fuel Capacity	12.5 gal. (47.3 L)
Engine Oil Capacity	2.5 qts. (2.4 L)
Coolant Capacity	7.8 qts. (5.1 L)
Towing Capacity	2000 lbs. (907 kg)
Hitch Tongue Capacity	150 lbs. (68 kg)
Max. Cargo Box Load	600 lbs. (272 kg)
Overall Length	152 in. (386 cm)
Overall Width	64 in. (163 cm)
Overall Height	75 in. (190.25 cm) (Without Roof Rack)
Wheelbase	117 in. (297 cm)
Cargo Box Dimensions (Inside)	36.2 x 47.25 x 13.5 in (92 x 120 x 34.3 cm)
Ground Clearance	14 in. (36)
Min. Turning Radius	244.8 in. (622 cm)
Engine	4-Stroke DOHC Twin Cylinder
Displacement	999 cc
Bore x Stroke	93 mm x 73.5 mm
Stator Output	660 W @ 3000 RPM
Compression Ratio	12.5:1
Starting System	Electric
Fuel System	Electronic fuel injection
Ignition System	Electronic
Spark Plug / Gap	MR7F / 0.7-0.8 mm
Front Suspension	Independent Double A-arm w/14 in. (35.6 cm) of travel



## SPECIFICATIONS

Rear Suspension	Independent Double A-arm w/15 in. (38.1 cm) of travel
Lubrication System	Wet Sump
Driving System Type	Automatic POLARIS Variable Transmission
Shift Type	Single Lever Dual Range (P/R/N/L/H)
Transmission Gear Ratio - High	Front 4.93:1 / Rear 14.73:1
Transmission Gear Ratio - Low	Front 10.92:1 / Rear 32.65:1
Transmission Gear Ratio - Reverse	Front 10.37:1 / Rear 31.01:1
Front Drive Ratio	3.08:1
Tire Size - Front	30x10R15 ProArmor Crawler XP
Tire Size - Rear	30x11R15 ProArmor Crawler XP
Tire Pressure - Front	18 psi (124 kPa)
Tire Pressure - Rear	22 psi (152 kPa)
Brakes, Front/Rear	Foot Activated, 4-wheel hydraulic disc
Hood Headlight	L.E.D.
Taillights	L.E.D.
Brake Light	L.E.D.
Instrument Cluster	Analog and LCD
Auxiliary DC Outlet	12V

## POLARIS XPEDITION ADV 5 ULTIMATE

Maximum Weight Capacity (including operator, passenger, cargo, non-factory installed accessories)	1160 lbs. (527 kg)
Dry Weight	2462 lbs. (1117 kg)
GVW (Gross Vehicle Weight)	3748 lbs. (1700 kg)
Fuel Capacity	12.5 gal. (47.3 L)
Engine Oil Capacity	2.5 qts. (2.4 L)
Coolant Capacity	7.8 qts. (7.4 L)
Towing Capacity	2000 lbs. (907 kg)
Hitch Tongue Capacity	150 lbs. (68 kg)

# SPECIFICATIONS

Max. Cargo Box Load	600 lbs. (272 kg)
Overall Length	152 in. (386 cm)
Overall Width	64 in. (163 cm)
Overall Height	75 in. (190.5 cm) (Without Roof Rack)
Wheelbase	117 in. (297 cm)
Cargo Box Dimensions (Inside)	36.2 x 47.25 x 13.5 in (92 x 120 x 34.3 cm)
Ground Clearance	14 in (36 cm)
Min. Turning Radius	244.8 in. (622 cm)
Engine	4-Stroke DOHC Twin Cylinder
Displacement	999 cc
Bore x Stroke	93 mm x 73.5 mm
Stator Output	900 W @ 3000 RPM
Compression Ratio	10.5:1
Starting System	Electric
Fuel System	Electronic fuel injection
Ignition System	Electronic
Spark Plug / Gap	MR7F / 0.7-0.8 mm
Front Suspension	Independent Double A-arm w/14 in. (35.6 cm) of travel
Rear Suspension	Independent Double A-arm w/15 in. (38.1 cm) of travel
Lubrication System	Wet Sump
Driving System Type	Automatic POLARIS Variable Transmission
Shift Type	Single Lever Dual Range (P/R/N/L/H)
Transmission Gear Ratio - High	Front 4.93:1 / Rear 14.73:1
Transmission Gear Ratio - Low	Front 10.92:1 / Rear 32.65:1
Transmission Gear Ratio - Reverse	Front 10.37:1 / Rear 31.01:1
Front Drive Ratio	3.08:1
Tire Size - Front	30x10R15 ProArmor Crawler XP
Tire Size - Rear	30x11R15 ProArmor Crawler XP

## SPECIFICATIONS

Tire Pressure - Front	18 psi (124 kPa)
Tire Pressure - Rear	22 psi (152 kPa)
Brakes, Front/Rear	Foot Activated, 4-wheel hydraulic disc
Hood Headlight	L.E.D.
Taillights	L.E.D.
Brake Light	L.E.D.
Instrument Cluster	Analog and LCD
Auxiliary DC Outlet	12V

## POLARIS XPEDITION ADV 5 NORTHSTAR

Maximum Weight Capacity (including operator, passenger, cargo, non-factory installed accessories)	1160 lbs. (527 kg)
Dry Weight	2801 lbs. (1270 kg)
GVW (Gross Vehicle Weight)	4087 lbs. (1854 kg)
Fuel Capacity	12.5 gal. (47.3 L)
Engine Oil Capacity	2.5 qts. (2.4 L)
Coolant Capacity	10 qts. (9.5 L)
Towing Capacity	2000 lbs. (907 kg)
Hitch Tongue Capacity	150 lbs. (68 kg)
Max. Cargo Box Load	600 lbs. (272 kg)
Overall Length	152 in. (386 cm)
Overall Width	64 in. (163 cm)
Overall Height	75 in. (190.5 cm) (Without Roof Rack)
Wheelbase	117 in. (297 cm)
Cargo Box Dimensions (Inside)	36.2 x 47.25 x 13.5 in (92 x 120 x 34.3 cm)
Ground Clearance	14 in (35.6 cm)
Min. Turning Radius	244.8 in. (622 cm)
Engine	4-Stroke DOHC Twin Cylinder
Displacement	999 cc

# SPECIFICATIONS

Bore x Stroke	93 mm x 73.5 mm
Alternator Output	1850 W (140A) @ 3000 RPM
Compression Ratio	10.5:1
Starting System	Electric
Fuel System	Electronic fuel injection
Ignition System	Electronic
Spark Plug / Gap	MR7F / 0.7-0.8 mm
Front Suspension	Independent Double A-arm w/14 in. (35.6 cm) of travel
Rear Suspension	Independent Double A-arm w/15 in. (38.1 cm) of travel
Lubrication System	Wet Sump
Driving System Type	Automatic POLARIS Variable Transmission
Shift Type	Single Lever Dual Range (P/R/N/L/H)
Transmission Gear Ratio - High	Front 4.93:1 / Rear 14.73:1
Transmission Gear Ratio - Low	Front 10.92:1 / Rear 32.65:1
Transmission Gear Ratio - Reverse	Front 10.37:1 / Rear 31.01:1
Front Drive Ratio	3.08:1
Tire Size - Front	30x10R15 ProArmor Crawler XP
Tire Size - Rear	30x11R15 ProArmor Crawler XP
Tire Pressure - Front	22 psi (152 kPa)
Tire Pressure - Rear	26 psi (179 kPa)
Brakes, Front/Rear	Foot Activated, 4-wheel hydraulic disc
Hood Headlight	L.E.D.
Taillights	L.E.D.
Brake Light	L.E.D.
Instrument Cluster	Analog and LCD
Auxiliary DC Outlet	12V

Dry weight is also listed on the Certificate of Origin for your vehicle in the Shipping Weight field. The dry weight is estimated based on the manufactured weight of the vehicle minus any serviceable fluids and may also exclude the weight of factory installed accessories not essential to the vehicle's basic operation as outlined in ANSI®/ROHVA® 1–2016 standard.

### **CLUTCHING (GENERAL)**

See your POLARIS dealer or qualified person for clutching specifications.

For operation at high elevation, different clutching parts may be needed. See you POLARIS dealer for more information.



# POLARIS PRODUCTS

## LUBRICANTS / SERVICE PRODUCTS

PRODUCT	SIZE (QUANTITY)	QUANTITY	PART NUMBER
Fogging Oil	12 fl oz (355 mL) aerosol	12	2870791
	1 qt (0.95 L)	12	2871517
PS-4	1 qt (0.95 L)	12	2876244
	2 qt (1.90 L)	8	2877490
	1 gal (3.8 L)	4	2876245
PS-4 Extreme Duty	1 qt (0.95 L)	12	2878920
	2 qt (1.90 L)	8	2878922
	1 gal (3.8 L)	4	2878919
	1 qt (0.95 L)	12	2889395
	1 gal (3.8 L)	4	2889396
AGL	1 qt (0.95 L)	12	2878068
	1 gal (3.8 L)	4	2878069
Pump for Gallon Jug	—	1	2870465
Demand Drive	1 qt (0.95 L)	12	2877922
	2.5 gal (9.5 L)	2	2877923
Antifreeze / Coolant	1 qt (0.95 L)	12	2880514
	1 gal (3.8 L)	6	2880513
Grease Gun Kit, Premium All Season	—	1	2871312
All Season Grease	Four 3 fl oz (89 mL) packs	6	2871322
	14 fl oz (414 mL) cartridge	1	2871423
Premium Starter Grease	—	1	2871460
U-Joint Grease	3 fl oz (89 mL) tube	24	2871515
	14 fl oz (414 mL) cartridge	1	2871551
Dielectric Grease (Nyogel®)	—	1	2871329

## POLARIS PRODUCTS

PRODUCT	SIZE (QUANTITY)	QUANTITY	PART NUMBER
Carbon Clean	12 fl oz (355 mL) bottle	12	2871326
Fuel Stabilizer	16 fl oz (473 mL)	12	2870652
	2.5 gal (9.5 L)	2	2872280
DOT 4 Brake Fluid	—	1	2872189
Loctite® 565 Thread Sealant	—	1	2871956
BatteryMINDER® 2012 AGM - 2 AMP Charger	—	1	2830438



# TROUBLESHOOTING

## DRIVE BELT WEAR/BURN

POSSIBLE CAUSE	SOLUTION
Driving onto a pickup or tall trailer in high range	Use low range during loading.
Starting out going up a steep incline	Use low range.
Driving at low RPM or ground speed – 3–7 mph (5–12 km/h)	Drive at a higher speed or use low range more frequently.
Insufficient warm-up at low ambient temperatures	Warm the engine at least 5 minutes. With the transmission in neutral, advance the throttle to about 1/8 throttle in short bursts, five to seven times. The belt will become more flexible and prevent belt burning. Always warm up the belt by operating below 30 mph (48 km/h) for 1 mile (1.6 km). When the temperature is below freezing, extend the belt warming time to 5 miles (8 km).
Slow/easy clutch engagement	Use the throttle quickly and effectively.
Towing/pushing at low RPM/low ground speed	Use low range only.
Utility use/plowing	Use low range only.
Stuck in mud or snow	Shift the transmission to low range and carefully use fast, aggressive throttle application to engage clutch. <b>WARNING: Excessive throttle may cause loss of control and vehicle rollover.</b>
Climbing over large objects from a stopped position	Shift the transmission to low range and carefully use fast, brief, aggressive throttle application to engage clutch. <b>WARNING: Excessive throttle may cause loss of control and vehicle rollover.</b>
Belt slippage from water or snow ingestion into the PVT system	Dry out the PVT. See PVT Drying procedure. Prevent water from entering the PVT intake duct. See Intake Pre-Filters for more information. Inspect clutch seals for damage if repeated leaking occurs.
Clutch malfunction	An authorized dealer can assist.
Poor engine performance	Check for clogged air filter, clogged fuel filter, water in the fuel or foreign material in fuel tank or fuel lines. An authorized dealer can assist.
Wrong belt	Install the recommended belt.
Improper break-in	Always break in a new belt and/or clutch. See PVT Break-in procedure.

## TROUBLESHOOTING

---

### ENGINE DOES NOT TURN OVER

POSSIBLE CAUSE	SOLUTION
Low battery voltage	Recharge the battery
Loose battery connections	Check all connections and tighten
Loose solenoid connections	Check all connections and tighten
Loose ECM (Electronic Control Module) connections	Inspect, clean, reinstall connectors

### ENGINE TURNS OVER, FAILS TO START

POSSIBLE CAUSE	SOLUTION
Out of fuel	Refuel
Water is present in fuel	Drain the fuel system and refuel
Old or non-recommended fuel	Replace with fresh recommended fuel
Fouled or defective spark plug	Inspect plug and replace if necessary
No spark to spark plug	Inspect plug and replace if necessary
Water or fuel in crankcase	Your authorized dealer can assist
Low battery voltage	Recharge the battery to 12.8 V DC
Mechanical failure	Your authorized dealer can assist

### ENGINE BACKFIRES

POSSIBLE CAUSE	SOLUTION
Weak spark from spark plug	Inspect, clean and/or replace spark plug
Incorrect spark plug gap or heat range	Set gap to specs or replace plug
Old or non-recommended fuel	Replace with fresh recommended fuel
Incorrectly installed spark plug wires	Your authorized dealer can assist
Mechanical failure	Your authorized dealer can assist
Loose ignition connections	Check all connections and tighten
Water present in fuel	Replace with fresh recommended fuel

## ENGINE PINGS OR KNOCKS

POSSIBLE CAUSE	SOLUTION
Poor quality or low octane fuel	Replace with recommended fuel
Incorrect spark plug gap or heat range	Set gap to specs or replace plug

## ENGINE RUNS IRREGULARLY, STALLS OR MISFIRES

POSSIBLE CAUSE	SOLUTION
Fouled or defective spark plug	Inspect, clean and/or replace spark plug
Worn or defective spark plug wires	Your authorized dealer can assist
Incorrect spark plug gap or heat range	Set gap to specs or replace plug
Loose ignition connections	Check all connections and tighten
Water present in fuel	Replace with new fuel
Low battery voltage	Recharge battery to 12.8 V DC
Incorrect fuel	Replace with recommended fuel
Clogged air filter	Inspect and clean or replace
Clogged intake pre-filter	Inspect and clean (with soapy water) or replace
Other mechanical failure	Your authorized dealer can assist

## ENGINE STOPS OR LOSES POWER

POSSIBLE CAUSE	SOLUTION
Out of fuel	Refuel
Water is present in fuel	Replace with new fuel
Fouled or defective spark plug	Inspect, clean and/or replace spark plug
Worn or defective spark plug wires	Your POLARIS dealer, or other qualified person, can assist
Incorrect spark plug gap or heat range	Set gap to specs or replace plug
Loose ignition connections	Check all connections and tighten
Low battery voltage	Recharge the battery to 12.8 V DC

## TROUBLESHOOTING

POSSIBLE CAUSE	SOLUTION
Incorrect fuel	Replace with fresh recommended fuel
Clogged air filter	Inspect and clean or replace
Throttle release switch malfunction	Your POLARIS dealer, or other qualified person, can assist
Other mechanical failure	Your POLARIS dealer, or other qualified person, can assist
Overheated engine	Clean radiator screen and core, clean engine exterior. Your POLARIS dealer, or other qualified person, can assist

## WARRANTY

### LIMITED WARRANTY

POLARIS Industries Inc., 2100 Highway 55, Medina, MN 55340 (POLARIS) gives a SIX MONTH LIMITED WARRANTY on all components of your POLARIS vehicle against defects in material or workmanship. Laws and regulations in your jurisdiction may give extra protection. POLARIS further warrants that the spark arrester in this product will meet the efficiency requirements of USFS standard 5100-1D for at least 1000 hours when subjected to normal use and when maintenance and installation are in accordance with POLARIS recommendations.

This warranty covers parts and labor charges for repair or replacement of defective parts and begins on the date of purchase by the original retail purchaser. The duration of this warranty may vary by international region based upon local laws and regulations.

### REGISTRATION

At the time of sale, the Warranty Registration Form must be completed by your dealer and submitted to POLARIS within ten days of purchase. Upon receipt of this registration, POLARIS will record the registration for warranty. No verification of registration will be sent to the purchaser as the copy of the Warranty Registration Form will be your proof of warranty coverage. If you have not signed the original registration and received the customer copy, please contact your dealer immediately. Initial dealer preparation and set-up of your vehicle is very important in ensuring trouble-free operation.

### **WARRANTY COVERAGE AND EXCLUSIONS**

#### **LIMITATIONS OF WARRANTIES AND REMEDIES**

This POLARIS limited warranty excludes any failures that are not caused by a defect in material or workmanship. **THIS WARRANTY DOES NOT COVER CLAIMS OF DEFECTIVE DESIGN.** This warranty also does not cover acts of God, accidental damage, normal wear and tear, abuse or improper handling. This warranty also does not cover any damage to any vehicle, component, or part as a result of being structurally altered or electrically, modified, neglected, improperly maintained or used for racing, competition or purposes other than for which it was designed.

This warranty excludes damages or failures resulting from improper lubrication; surface imperfections caused by external stress, heat, cold or contamination; operator error or abuse; improper component alignment, tension, adjustment; snow, water, dirt or other foreign substance ingestion/contamination; improper maintenance; modified components; use of aftermarket or unapproved components, accessories, or attachments; use of unapproved software or calibration; unauthorized repairs; or repairs made after the warranty period expires or by an unauthorized repair center.

This warranty excludes the expected reduction in range or capacity that the high-voltage battery pack may experience as a result of time and usage. However, a high-voltage battery pack that exhibits a capacity reduction in excess of 20% of the published nominal capacity is covered under the limited warranty. The reduction would need to be verified by an authorized dealer by checking the battery management system (BMS) log data.

This warranty excludes non-recoverable high-voltage battery packs. It is the owner's responsibility to ensure the state of charge (SoC) of the high-voltage battery is maintained properly and never fully depleted. If the high-voltage battery charge becomes fully depleted, the high-voltage battery can cease operating permanently (also known as non-recoverable)

This warranty excludes damages or failures caused by abuse, accident, fire, or any other cause other than a defect in materials or workmanship and provides no coverage for consumable components, general wear items, or any parts exposed to friction surfaces, stresses, environmental conditions and/or contamination for which they were not designed or not intended, including but not limited to the following items:

- Wheels and tires
- Suspension components
- Brake components
- Seat components
- Steering components
- 12-Volt Battery
- Light bulbs/Sealed beam lamps
- Lubricants
- Finished and unfinished surfaces
- Bushings
- Hydraulic components and fluids
- Circuit breakers/Fuses
- Electronic components
- Sealants
- Coolants
- Bearings

## LUBRICANTS AND FLUIDS

Damage or failure resulting from the use of non-recommended lubricants or fluids is not covered by this warranty.

This warranty provides no coverage for personal loss or expense, including mileage, transportation costs, hotels, meals, shipping or handling fees, product pick-up or delivery, replacement rentals, loss of product use, loss of profits, or loss of vacation or personal time.

THE EXCLUSIVE REMEDY FOR BREACH OF THIS WARRANTY SHALL BE, AT Polaris' OPTION, REPAIR OR REPLACEMENT OF ANY DEFECTIVE MATERIALS, COMPONENTS, OR PRODUCTS. THE REMEDIES SET FORTH IN THIS WARRANTY ARE THE ONLY REMEDIES AVAILABLE TO ANY PERSON FOR BREACH OF THIS WARRANTY. Polaris SHALL HAVE NO LIABILITY TO ANY PERSON FOR INCIDENTAL, CONSEQUENTIAL OR SPECIAL DAMAGES OF ANY DESCRIPTION, WHETHER ARISING OUT OF EXPRESS OR IMPLIED WARRANTY OR ANY OTHER CONTRACT, NEGLIGENCE, OR OTHER TORT OR OTHERWISE. THIS EXCLUSION OF CONSEQUENTIAL, INCIDENTAL, AND SPECIAL DAMAGES IS INDEPENDENT FROM AND SHALL SURVIVE ANY FINDING THAT THE EXCLUSIVE REMEDY FAILED OF ITS ESSENTIAL PURPOSE.

THE IMPLIED WARRANTY OF FITNESS FOR A PARTICULAR PURPOSE IS EXCLUDED FROM THIS LIMITED WARRANTY. ALL OTHER IMPLIED WARRANTIES (INCLUDING BUT NOT LIMITED TO THE IMPLIED WARRANTY OF MERCHANTABILITY) ARE LIMITED IN DURATION TO THE ABOVE SIX MONTH WARRANTY PERIOD. Polaris DISCLAIMS ALL EXPRESS WARRANTIES NOT STATED IN THIS WARRANTY. SOME STATES DO NOT PERMIT THE EXCLUSION OR LIMITATION OF INCIDENTAL OR CONSEQUENTIAL DAMAGES OR ALLOW LIMITATIONS ON THE DURATION OF IMPLIED WARRANTIES, SO THE ABOVE LIMITATIONS MAY NOT APPLY TO YOU IF INCONSISTENT WITH CONTROLLING STATE LAW.

## WARRANTY

---

### **HOW TO OBTAIN WARRANTY SERVICE**

If your vehicle requires warranty service, you must take it to a POLARIS Servicing Dealer. When requesting warranty service you must present your copy of the Warranty Registration Form to the dealer. (THE COST OF TRANSPORTATION TO AND FROM THE DEALER IS YOUR RESPONSIBILITY.) POLARIS suggests that you use your original selling dealer; however, you may use any POLARIS Servicing Dealer to perform warranty service.

### **IN THE COUNTRY WHERE YOUR PRODUCT WAS PURCHASED:**

You are responsible for presenting your vehicle to an authorized POLARIS dealer as soon as a problem exists. The warranty repairs should be completed in a reasonable amount of time, not to exceed 30 days. However, any damage caused to the product by you or any non-authorized third party may void this warranty. Warranty or Service Bulletin repairs must be done by an authorized POLARIS dealer, or other qualified person authorized by POLARIS.

### **OUTSIDE THE COUNTRY WHERE YOUR PRODUCT WAS PURCHASED:**

If you are traveling temporarily outside the country where your product was purchased, you should take your product to an authorized POLARIS dealer, or other qualified person authorized by POLARIS. You must show the dealer photo identification from the country of the selling dealer's authorized location as proof of residence. Upon residence verification, the servicing dealer will be authorized to perform the warranty repair.

### **IF YOU MOVE:**

If you move to another country, be sure to contact POLARIS Customer Assistance and the customs department of the destination country before you move. Product importation rules vary considerably from country to country. You may be required to present documentation of your move to POLARIS in order to continue your warranty coverage. You may also be required to obtain documentation from POLARIS to register your product in your new country. We recommend that you register your product at a local authorized POLARIS dealer promptly after you move.

### **IF YOU PURCHASE FROM A PRIVATE PARTY:**

If you purchase a POLARIS product from a private party, to be kept and used outside of the country in which the product was originally purchased, all warranty coverage will be denied. However, we encourage you to promptly register your product at your local authorized POLARIS dealer to receive safety information and notice regarding your product.



---

## EXPORTED PRODUCTS

EXCEPT WHERE SPECIFICALLY REQUIRED BY LAW, THERE IS NO WARRANTY OR SERVICE BULLETIN COVERAGE ON THIS PRODUCT IF IT IS SOLD OUTSIDE THE COUNTRY OF THE SELLING DEALER'S

**AUTHORIZED LOCATION.** This policy does not apply to products that have received authorization for export from POLARIS. Dealers may not give authorization for export. You should consult an authorized dealer to determine this product's warranty or service coverage if you have any questions. This policy does not apply to products registered to government officials or military personnel on assignment outside the country of the selling dealer's authorized location. This policy does not apply to Safety Bulletins

### NOTICE

If vehicle is equipped with windshield, remove windshield, or tilt windshield up. Remove any hardware attached to ROPS right-hand A-pillar.

## U.S.A. EPA EMISSIONS LIMITED WARRANTY

This emissions limited warranty is in addition to the POLARIS standard limited warranty for your vehicle. POLARIS Industries Inc. warrants that at the time it is first purchased, this emissions-certified vehicle is designed, built and equipped so it conforms with applicable U.S. Environmental Protection Agency emission regulations. POLARIS warrants that the vehicle is free from defects in materials and workmanship that would cause it to fail to meet these regulations.

The warranty period for off road vehicles 100cc or greater emissions-certified vehicles starts on the date of purchase by original retail purchaser and continues for a period of 500 hours of engine operation, 5000 kilometers (3100 miles) of vehicle travel, or 30 calendar months from the date of purchase, whichever comes first. The warranty period for ATVs less than 100cc emissions-certified vehicles starts on the date of purchase by original retail purchaser and continues for a period of 250 hours of engine operation, 2500 kilometers (1550 miles) of vehicle travel, or 30 calendar months from the date of purchase, whichever comes first. This EPA emissions warranty period is extended for at least as long as the standard factory warranty that Polaris provides on the vehicle as a whole. The EPA emissions warranty period does not further extend if you purchase additional warranty coverage in the form of a service contract or other paid warranty extension, but emission-related parts may be covered subject to the terms of any such paid service contract or paid warranty extension

This emissions limited warranty covers components whose failure increases the vehicle's regulated emissions, and it covers components of systems whose only purpose is to control emissions. Repairing or replacing other components not covered by this warranty is the responsibility of the vehicle owner. This emissions limited warranty does not cover components whose failure does not increase the vehicle's regulated emissions.

## WARRANTY

---

For exhaust emissions, emission-related components include any engine parts related to the following systems:

- Air-induction system
- Fuel system
- Ignition system
- Exhaust gas recirculation systems

The following parts are also considered emission-related components for exhaust emissions:

- Aftertreatment devices
- Crankcase ventilation valves
- Sensors
- Electronic control units

The following parts are considered emission-related components for evaporative emissions:

- Fuel Tank
- Fuel Cap
- Fuel Line
- Fuel Line Fittings
- Clamps\*
- Pressure Relief Valves\*
- Control Valves\*
- Control Solenoids\*
- Electronic Controls\*
- Vacuum Control Diaphragms\*
- Control Cables\*
- Control Linkages\*
- Purge Valves
- Vapor Hoses
- Liquid/Vapor Separator
- Carbon Canister
- Canister Mounting Brackets
- EFI Purge Port Connector

\*As related to the evaporative emission control system.

Emission-related components also include any other part whose only purpose is to reduce emissions or whose failure will increase emissions without significantly degrading engine/equipment performance. The exclusive remedy for breach of this limited warranty shall be, at the exclusive option of POLARIS, repair or replacement of any defective materials, components or products. THE REMEDIES SET FORTH IN THIS LIMITED WARRANTY ARE THE ONLY REMEDIES AVAILABLE TO ANY PERSON FOR BREACH OF THIS WARRANTY. POLARIS SHALL HAVE NO LIABILITY TO ANY PERSON FOR INCIDENTAL, CONSEQUENTIAL OR SPECIAL DAMAGES OF ANY DESCRIPTION, WHETHER ARISING OUT OF EXPRESS OR IMPLIED WARRANTY OR ANY OTHER CONTRACT, NEGLIGENCE OR OTHER TORT OR OTHERWISE. THIS EXCLUSION OF CONSEQUENTIAL, INCIDENTAL, AND SPECIAL DAMAGES IS INDEPENDENT FROM AND SHALL SURVIVE ANY FINDING THAT THE EXCLUSIVE REMEDY FAILED OF ITS ESSENTIAL PURPOSE.

ALL IMPLIED WARRANTIES (INCLUDING BUT NOT LIMITED TO ANY IMPLIED WARRANTIES OF MERCHANTABILITY AND FITNESS FOR A PARTICULAR PURPOSE) ARE LIMITED IN DURATION TO THE WARRANTY PERIOD DESCRIBED HEREIN. POLARIS DISCLAIMS ALL EXPRESS WARRANTIES NOT STATED IN THIS WARRANTY. Some states do not allow limitations on how long an implied warranty lasts, so the above limitation may not apply if it is inconsistent with the controlling state law.

This limited warranty excludes failures not caused by a defect in material or workmanship. This limited warranty does not cover damage due to accidents, abuse or improper handling, maintenance or use. This limited warranty also does not cover damage to any engine as a result of being structurally altered, or when the vehicle has been used in racing competition. This limited warranty also does not cover physical damage, corrosion or defects caused by fire, explosions or other similar causes beyond the control of POLARIS.

## WARRANTY

---

Owners are responsible for performing the scheduled maintenance identified in the owner's manual. POLARIS may deny warranty claims for failures that have been caused by the owner's or operator's improper maintenance or use, by accidents for which POLARIS has no responsibility, or by acts of God.

Any qualified repair shop or person may maintain, replace, or repair the emission control devices or systems on your vehicle. An authorized POLARIS dealer, or other qualified person, can perform any service that may be necessary for your vehicle. POLARIS also recommends POLARIS parts, however equivalent parts may be used for such service. It is a potential violation of the Clean Air Act if a part supplied by an aftermarket parts manufacturer reduces the effectiveness of the vehicle's emission controls. Tampering with emission controls is prohibited by federal law.

---

## CALIFORNIA RESIDENTS

Certain POLARIS Off-Road Vehicles are available in 49-state and 50-state versions. Only the 50-state models are certified for sale in California. The 50-state models available for sale in California are identified by the letter “B” in the ninth position of the model number (e.g., R16RTE87B). The POLARIS 50-state models are designed and built with features such as a reduced cargo box capacity. Any modifications to these features may be a violation of the applicable California regulations and may void this limited emissions warranty offered by the manufacturer.

POLARIS Industries Inc. warrants that at the time it is purchased, this vehicle is:

1. Designed, built, and equipped so as to conform, at the time of sale, with all applicable California evaporative emissions regulations.
2. Free from defects in materials and workmanship that may cause the failure of a warranted part as defined in California evaporative emissions regulations. All replacement parts must be identical in all material respects to that part as described in the OHRV manufacturer’s Executive Order of Certification application.

The California evaporative emissions control system limited warranty statement below applies to your Off Highway Recreational Vehicle in California if the vehicle is equipped with an evaporative emission control system and is labeled with a Vehicle Evaporative Emissions Control Information label indicating that the vehicle conforms to California evaporative emissions regulations applicable to new off-road sport vehicles, all-terrain vehicles, or off-road utility vehicles. These vehicles are referred to as “OHRV-EVAP” below.

### **CALIFORNIA EMISSION CONTROL WARRANTY STATEMENT YOUR WARRANTY RIGHTS AND OBLIGATIONS**

The California Air Resources Board and Polaris Industries Inc. are pleased to explain the emission control system warranty on your model year 2018 and newer Off Highway Recreational Vehicle. In California, new off-highway recreational vehicles must be designed, built and equipped to meet the State’s stringent anti-smog standards. Polaris must warrant the emission control system on your OHRV-EVAP for the periods of time listed below provided there has been no abuse, neglect or improper maintenance of your OHRV-EVAP.

Your emission control system may include parts such as the carburetor or fuel injection system, fuel tank, fuel hoses, carbon canister, engine computer and Evaporative Emissions Control System parts listed in the U.S.A. EPA Emissions Limited Warranty. Also included may be hoses, belts, connectors and other emission-related assemblies. Where a warrantable condition exists, Polaris will repair your OHRV-EVAP at no cost to you including diagnosis, parts and labor.

### **MANUFACTURER’S WARRANTY COVERAGE:**

For model year 2018 and newer OHRV-EVAP models.

## WARRANTY

---

For 30 months, or 2500 miles (4023 km), or 250 hours, whichever comes first, except for evaporative components over the OHRV high-priced warranty value, which is covered for 60 months, or 5000 miles (8047 km), or 500 hours, whichever comes first.

If any emission-related part on your OHRV-EVAP is defective, the part will be repaired or replaced by Polaris.

### OWNER'S WARRANTY RESPONSIBILITIES:

As the OHRV-EVAP owner, you are responsible for the performance of the required maintenance listed in your owner's manual. Polaris recommends that you retain all receipts covering maintenance on your OHRV-EVAP, but Polaris cannot deny warranty solely for the lack of receipts or for your failure to ensure the performance of a scheduled maintenance.

As an owner you are responsible for presenting your OHRV-EVAP to a Polaris dealer as soon as a problem exists. The warranty repairs should be completed in a reasonable amount of time, not to exceed 30 days.

As an OHRV-EVAP owner, you should also be aware that Polaris may deny you warranty coverage if your OHRV-EVAP or a part has failed due to abuse, neglect, improper maintenance or unapproved modifications.

### ADD-ON OR MODIFIED PARTS

An add-on or modified part must be compliant with applicable CARB emission control standards. A violation of this requirement is punishable by civil and/or criminal punishment.

If you have any questions regarding your warranty rights and responsibilities, you should contact Polaris Customer Assistance at 1-800-POLARIS (1-800-765-2747) or the California Air Resources Board at 9528 Telstar Avenue, El Monte, CA 91731.

United States & Canada: 1-800-POLARIS (1-800-765-2747)

French: 1-800-268-6334

## CALIFORNIA EMISSIONS

### How the California Emissions Warranty on Evaporative Emission Parts Must Function as Prescribed in 13 CCR § 2419.1

(1) Any warranted part which is not scheduled for replacement as part of maintenance in the Owner's Manual must be warranted for the warranty period. If any such part fails during the warranty period, it must be repaired or replaced by POLARIS according to subdivision (4) below. Any such part repaired or replaced under warranty must be fully warranted.

- (2) Any warranted part which is scheduled only for regular inspection in the Owner's Manual must be warranted for the warranty period. A statement in such written instructions to the effect of "repair or replace as necessary" must not reduce the period of warranty coverage. Any such part repaired or replaced under warranty must be warranted for the remaining warranty period.
- (3) Any warranted part which is scheduled for replacement as part of maintenance in the Owner's Manual must be warranted for the period of time prior to the first scheduled replacement point for that part. If the part fails before the first scheduled replacement point, the part must be repaired or replaced by POLARIS according to subdivision (4). Any such part repaired or replaced under warranty must be warranted for the remainder of the period prior to the first scheduled replacement point for the part.
- (4) Repair or replacement of any warranted part under the warranty provisions of this Article must be performed at no charge to the OHRV owner, at a warranty station, except in the case of a temporary repair when a warranted part or a warranty station is not reasonably available to the OHRV owner. In the event a temporary repair is permitted according to subdivision (8) below, repairs may be performed at any available service establishment, or by the owner, using any replacement part. POLARIS must reimburse the owner for his or her expenses including diagnostic charges for such temporary repair or replacement, not to exceed POLARIS' suggested retail price for all warranted parts replaced and labor charges based on the POLARIS recommended time allowance for the warranty repair and the geographically appropriate hourly labor rate.
- (5) Notwithstanding the provisions of subdivision (4) above, warranty services or repairs must be provided at all POLARIS dealerships that are owned by POLARIS or franchised to service the subject OHRVs.
- (6) The OHRV owner must not be charged for diagnostic labor which leads to the determination that a warranted part is, in fact, defective, provided that such diagnostic work is performed at a warranty station.
- (7) POLARIS is liable for damages to other vehicle components proximately caused by a failure, under warranty, of any warranted part.
- (8) Throughout the OHRV's evaporative emissions warranty period, POLARIS must maintain a supply of warranted parts sufficient to meet the expected demand for such parts. The lack of availability of such parts or the incompleteness of repairs within a reasonable time period, not to exceed 30 days from the time the OHRV is initially presented to the warranty station for repair, will qualify the need for a temporary repair for purposes of subdivision (4).
- (9) Any replacement part designated by POLARIS may be used in warranty repairs provided without charge to the OHRV owner. Such use will not reduce the warranty obligations of POLARIS, except that POLARIS will not be liable under the provisions of this Article for repair or replacement of any replacement part which is not a warranted part (except as provided under subdivision (d)(7)).

## WARRANTY

---

(10) Any add-on or modified part exempted by the Air Resources Board from the prohibitions of section 27156 of the California Vehicle Code may be used on an OHRV. Such use, in and of itself, will not be grounds for disallowing a warranty claim made under the provisions of this Article. POLARIS is not liable under the provisions of this Article to warrant failures of warranted parts caused by the use of an add-on or modified part(s) unless such part(s) are also warranted.

(11) Upon a request of the Executive Officer, POLARIS must provide any documents that describe the manufacturer's warranty procedures or policies.

(12) Any replacement part must not reduce the effectiveness of the OHRV emission control system. POLARIS must demonstrate that the applicable emission standards are being met when the replacement part(s) are installed on the OHRV. The demonstration of equivalence to applicable emission standards can be achieved through replacing the part(s) with the evaporative emissions control components the OHRV evaporative family was certified with; or, if unavailable, alternative parts may be installed if POLARIS can provide test data to verify the evaporative control system meets, at least, the OHRV EFEL.

### **Exclusion**

Notwithstanding the provisions of subdivisions (1) - (12) above, the repair or replacement of any warranted part otherwise eligible for the California Warranty on Evaporative Emission Parts, is excluded from such warranty coverage if POLARIS can provide evidence to the California Air Resources Board Executive Officer, to the Executive Officer's satisfaction, that the OHRV has been abused, neglected, improperly maintained, or had unapproved modifications and that such abuse, neglect, improper maintenance, or unapproved modification, was the direct cause of the need for the repair or replacement of the part.







---

<b>A</b>		Crankcase Emission Control System ..... 95
Adding or Changing Coolant ..... 117		
ADV 5 ..... 118		
Air Conditioning ..... 120		
Air Filter ..... 128		
Air Filter / Air Box ..... 148		
All Wheel Drive/Rear Differential System ..... 89		
Auxiliary Outlet ..... 45		
AWD / Differential Lock Switch ..... 41		
<b>B</b>		
Battery		
Installation ..... 142		
Overview ..... 139		
Removal ..... 140		
Battery Maintenance ..... 148		
Battery Maintenance and Charging ..... 143		
Battery Trickle-Charging Outlet ..... 46		
Belt Replacement ..... 122		
Body		
Front Seat		
Removal ..... 50		
Installation ..... 50		
Brake Fluid ..... 130		
Brake Inspection ..... 131		
Brake Pedal ..... 47		
Brakes ..... 130		
Braking ..... 87		
<b>C</b>		
California Emissions ..... 180		
California Residents ..... 179		
Cargo ..... 91		
Check Engine Indicator ..... 69		
Clean the Exterior ..... 148		
Clutching ..... 163		
Component Locations		
ADV 5 ..... 38		
ADV Models ..... 38		
Cooling System ..... 117		
<b>D</b>		
		Device Compliance Statements .... 72
		Display Mode ..... 80
		Display Units, Standard/Metric ..... 66
		Drive Belt Wear/Burn ..... 167
		Drying the Transmission ..... 126
<b>E</b>		
		Electromagnetic Interference ..... 95
		Electronic Power Steering ..... 56
		Emissions Limited Warranty ..... 175
		Engine
		NorthStar Models Only ..... 110
		Oil and Filter Change ..... 110
		Oil Level ..... 104
		Engine Backfires ..... 168
		Engine Does Not Turn Over ..... 168
		Engine Oil ..... 103
		Engine Oil Change ..... 106
		Engine Pings or Knocks ..... 169
		Engine Runs Irregularly, Stalls or Misfires ..... 169
		Engine Turns Over, Fails to Start ..... 168
		Error Codes, Engine ..... 69
		Exhaust Emission Control System ..... 95
		Exhaust System Warning ..... 129
		Exported Products ..... 175
<b>F</b>		
		Fan, Cooling ..... 117
		Filter Systems ..... 128
		Fluid Change
		Engine Oil ..... 106
		Front Gearcase ..... 114
		Main Gearcase ..... 113
		Transmission ..... 113
		Fluid Check

---

Front Gearcase .....	114
Main Gearcase .....	113
Transmission .....	113
Fluid Levels .....	149
Fluid Part Numbers .....	165
Fog the Engine .....	149
Fouled Plugs .....	116
Front Gearcase .....	114
Front/Rear Spring Preload .....	132
Fuel Cap .....	57
Fuel Recommendation .....	86
Fuel Stabilizer .....	148
Fuses .....	135-136

## G

Gap, Spark Plug .....	115
Gear Selector .....	40
Gearcase Specification Chart .....	114
Gearcase, Front .....	114
Gearcases .....	113
Gears, Shifting .....	40

## H

Hauling Cargo .....	91
Headlight Beam Adjustment .....	139
Headlight Replacement .....	138
Hitch .....	56
Hitch Weight .....	92
Hood .....	58
How To Obtain Warranty Service .....	174
HVAC Control Panel .....	44

## I

Ignition Switch .....	41
Indicator Lamps .....	62
Instrument Cluster .....	59
Toggle Buttons .....	61

## L

Labels .....	25, 32
Air Filter Caution .....	28, 35
Belt Warning .....	27, 34
Proper Use Warning .....	24, 31
Tip Out Windshield Warning NorthStar Models Only .....	29, 35
Light Switch .....	42
Lights .....	138
Limited Warranty .....	171
Load Capacity .....	91
Lubricants / Service Products .....	165
Lubrication Recommendations .....	101
Lug Nut Inspection .....	134
Lug Nut Torque .....	134
Lug Nut Torque Specifications .....	134

## M

Main Gearcase .....	113
Maintenance Log .....	183
Maintenance Overview .....	97
Maximum Payload Tire Pressure Warning .....	25, 32
Metric Display .....	66
Mode Button .....	61
Mode Information Displays .....	64

## N

Near Field Communication (NFC) .....	37
Noise Emission Control System .....	95
NorthStar Models .....	136

## O

Oil and Filter .....	148
Oil Change Engine .....	106
Front Gearcase .....	114
Main Gearcase .....	113
Non-Northstar .....	106
Transmission .....	113
Oil Level	

Front Gearcase .....	114
Main Gearcase .....	113
Transmission .....	113
Oil Recommendations .....	103
Operation on Public Lands in the U.S.A. ....	95

## P

Part Numbers .....	165
PIN Activated Security System (P.A. S.S.) (if equipped) Ride Command .....	77
Plug Gap .....	115
Plug Torque .....	115
Plugs, Fouled .....	116
Plugs, Spark .....	115
Polaris 3-Mode Throttle Control Switch .....	42
Polaris Products .....	165
POLARIS Variable Transmission System .....	122
Polishing the Vehicle .....	147
Power Steering .....	56
Power Steering Unit Cleaning .....	127
Premium Models .....	131, 135
Programmable Service Interval .....	68
PVT Drying .....	126

## R

Radiator and Cooling Fan .....	117
Radiator Coolant Level / Changing Coolant .....	118
Rear Folding Seat .....	53
Receiver Hitch .....	56
Registration, Warranty .....	171
Removal from Storage .....	150
Ride Command Before You Ride .....	71
Buttons .....	75
Driveline Mode .....	78
Gauge Screens .....	78
Gauge View Mode .....	80
Icon Bar .....	81

Overview .....	74
Settings .....	79
RIDE COMMAND+ .....	83
Rider Information Center .....	63
Rollover Protective Structure (ROPS) .....	56

## S

Safe Operating Guidelines Stopping the Engine and Parking the Vehicle .....	88
Safe Operation Practices Driving in Reverse .....	88
Safety Driver and Passenger Qualifications .....	10
Driving Guidelines .....	16
Owner Requirements .....	9
Prepare Vehicle for the Ride .....	11
Prepare Yourself, Passengers, and Cargo for the Ride .....	14
Safety Labels and Locations Overview .....	23
Overview, ADV 5 .....	30
Safety Symbols .....	4
Seat Belt .....	48
Shifter .....	40
Shock Compression .....	132
Shock Spring Adjustment .....	131
Side Steps .....	57
Signal Words .....	4
Spark Arrester .....	129
Spark Plug Inspection .....	115
Spark Plug Recommendations .....	115
Specifications ADV 5 NorthStar .....	161
ADV 5 Ultimate .....	159
POLARIS XPEDITION ADV 5 Premium .....	158
POLARIS XPEDITION ADV NorthStar .....	156
POLARIS XPEDITION ADV Premium .....	153
POLARIS XPEDITION ADV Ultimate .....	154
Spring Preload .....	132

---

Stabilize the Fuel .....	148
Starting the Engine .....	87
Steering Wheel Inspection .....	127
Steering Wheel, Adjustment .....	39
Storage .....	148
Storage Area .....	149
Storage Compartment, Front .....	49
Switches .....	41
Ignition Switch .....	41
Light Switch .....	42
Mode Button .....	61
Window .....	45

## T

Tachometer .....	61
Throttle Pedal .....	47
Tire Tread Depth .....	134
Tires .....	133
Tools for Safe Riding .....	7
Torque, Lug Nut .....	134
Torque, Spark Plug .....	115
Towing Loads .....	92
Towing the POLARIS XPEDITION .....	94, 150
Trailer Hitch Bracket .....	56
Transmission .....	113
Drying .....	126
Oil .....	113
Transporting the POLARIS XPEDITION .....	94, 150

## U

Ultimate Models .....	135
Update Maps .....	83
Update Software .....	82
USB Outlet .....	46

## V

Vehicle Break-in Brake System Break-in .....	85
Engine and Drivetrain Break-in .....	85

PVT Break-in (Clutches / Belt) ...	85
Vehicle Identification Numbers .....	8
Vehicle Immersion .....	126
Vehicle-to-Vehicle Communication (V2V) .....	71

## W

Warning Symbols .....	4
Washing the Vehicle .....	146
Water Forging Level .....	59
Water, Immersion of Vehicle .....	126
Welcome Page .....	3
Wet Fouled Plug .....	116
Wheel Installation .....	134
Wheel Removal .....	134
Winch Switch (if equipped) .....	43
Windshield Wiper/Washer Switch (if equipped) .....	44





For your nearest Polaris dealer,  
call 1-800-POLARIS (765-2747)  
or visit [www.polaris.com](http://www.polaris.com)

Polaris Inc.  
2100 Highway 55  
Medina, MN 55340



Part No. 9940600 Rev 02  
Printed in USA