

2023



For Maintenance and Safety

# OWNER'S MANUAL

RANGER SP 570  
RANGER CREW SP 570

**POLARIS**  
Think Outside



## **WARNING**

Read, understand, and follow all of the instructions and safety precautions in this manual and on all product labels.

Failure to follow the safety precautions could result in serious injury or death.



## **WARNING**

Operating, servicing, and maintaining a passenger vehicle or off-road vehicle can expose you to chemicals including engine exhaust, carbon monoxide, phthalates, and lead, which are known to the State of California to cause cancer and birth defects or other reproductive harm. To minimize exposure, avoid breathing exhaust, do not idle the engine except as necessary, service your vehicle in a well-ventilated area and wear gloves or wash your hands frequently when servicing your vehicle.

For more information go to [www.P65Warnings.ca.gov/passenger-vehicle](http://www.P65Warnings.ca.gov/passenger-vehicle).



*For videos and more information  
about a safe riding experience with  
your Polaris vehicle, scan this QR  
Code® with your smartphone  
or visit: [www.polaris.com/en-us/safety](http://www.polaris.com/en-us/safety)*

**POLARIS**  
***RANGER***<sup>®</sup>

***2023 Owner's Manual***

***RANGER SP 570***  
***RANGER SP 570 Premium***  
***RANGER SP 570 NorthStar Edition***  
***RANGER CREW SP 570***  
***RANGER CREW SP 570 Premium***  
***RANGER CREW SP 570 NorthStar***  
***Edition***

Unless noted, trademarks are the property of Polaris Industries Inc. Loctite® is a registered trademark of Henkel Corporation. Recreational Off-Highway Vehicle Association® and ROHVA® are registered trademarks of Recreational Off-Highway Vehicle Association. WD-40® is registered to WD-40 Manufacturing Company. QR Code® is a registered trademark of DENSO WAVE INCORPORATED. OSHA® is a registered trademark of the Occupational Safety and Health Administration. U. S. Dept. of Labor, MACPHERSON RIDE® is a trademark of Aftermarket Auto Parts Alliance, Inc. NGK® is a registered trademark of NGK Spark Plug Co., Ltd. Tread Lightly® is a registered trademark of the United States Department of Agriculture. Autolite® is a registered trademark of BMO HARRIS BANK N.A. Google Play® is a registered trademark of Google LLC. BatteryMINDer® is a registered trademark of VDC Electronics Inc. Apple® and APP Store® are registered trademarks of Apple Inc. NYOGEL® is a registered trademark of Nye Lubricants, Inc.

Copyright 2023 Polaris Industries Inc. All information contained within this publication is based on the latest product information at the time of publication. Due to constant improvements in the design and quality of production components, some minor discrepancies may result between the actual vehicle and the information presented in this publication. Depictions and/or procedures in this publication are intended for reference use only. No liability can be accepted for omissions or inaccuracies. Any reprinting or reuse of the depictions and/or procedures contained within, whether whole or in part, is expressly prohibited.

The original instructions for this vehicle are in English. Other languages are provided as translations of the original instructions.

Printed in U.S.A.

9940856 R03



Thank you for purchasing a POLARIS vehicle, and welcome to our world-wide family of POLARIS enthusiasts. Be sure to visit us online at [www.polaris.com](http://www.polaris.com) for the latest news, new product introductions, upcoming events, career opportunities and more.

Here at POLARIS we proudly produce an exciting line of utility and recreational products. We believe POLARIS sets a standard of excellence for all utility and recreational vehicles manufactured in the world today. Many years of experience have gone into the engineering, design, and development of your POLARIS vehicle, making it the finest machine we've ever produced.

For safe and enjoyable operation of your vehicle, be sure to follow the instructions and recommendations in this owner's manual. Your manual contains instructions for minor maintenance, but information about major repairs is outlined in the POLARIS Service Manual and can be performed by a factory certified Master Service Dealer (MSD) technician.

Your POLARIS dealer knows your vehicle best and is interested in your total satisfaction. Your POLARIS dealership can perform all of your service needs during and after the warranty period.

For the most up-to-date owner's manual visit <https://www.polaris.com/en-us/owners-manuals>.

WELCOME

---

---

<b>Introduction . . . . .</b>	<b>7</b>
<b>Safety . . . . .</b>	<b>11</b>
<b>Features and Controls . . . . .</b>	<b>33</b>
<b>Operation . . . . .</b>	<b>67</b>
<b>Emission Control Systems . . . . .</b>	<b>79</b>
<b>Maintenance . . . . .</b>	<b>81</b>
<b>Specifications . . . . .</b>	<b>141</b>
<b>POLARIS Products . . . . .</b>	<b>147</b>
<b>Troubleshooting . . . . .</b>	<b>149</b>
<b>Warranty . . . . .</b>	<b>155</b>
<b>Maintenance Log . . . . .</b>	<b>165</b>





# INTRODUCTION

## BEFORE YOU RIDE

This POLARIS vehicle is an off-road vehicle. Familiarize yourself with all laws and regulations concerning the operation of this vehicle in your area.

### WARNING

Failure to heed the warnings and safety precautions contained in this manual can result in severe injury or death. Your POLARIS vehicle is not a toy and can be hazardous to operate. This vehicle handles differently than cars, trucks or other off-road vehicles. A collision or rollover can occur quickly, even during routine maneuvers like turning, or driving on hills or over obstacles, if you fail to take proper precautions.

- Read this owner's manual and review the safety DVD that came with your vehicle. A free extra copy of the DVD can be obtained by contacting your local POLARIS dealer. Understand all safety warnings, precautions and operating procedures before operating the vehicle. Keep this manual with the vehicle.
- Never operate this vehicle without proper instruction. Take an authorized training course. See the Safety Training section for more information.
- This vehicle is an **ADULT VEHICLE ONLY**. You **MUST** be at least age 16 and have a valid driver's license to operate this vehicle.
- Always use the cab nets (or doors) while riding in this vehicle. Always keep hands, feet and all other body parts inside the vehicle at all times.
- Always wear a helmet, eye protection, gloves, long-sleeve shirt, long pants and over-the-ankle boots.
- Never operate this vehicle under the influence of drugs or alcohol, as these conditions impair judgement and reduce the operator's ability to react.
- Complete the New Operator Driving Procedures outlined in this manual. Never allow a guest to operate this vehicle until the guest has completed the New Operator Driving Procedures.
- Never permit a guest to operate this vehicle unless the guest has reviewed the owner's manual and all safety labels and has completed a safety training

### IMPORTANT

For more information about safety, contact an authorized dealer or visit the Polaris website at [www.polaris.com](http://www.polaris.com).

## INTRODUCTION

---

### SAFETY SYMBOLS AND SIGNAL WORDS

The following signal words and symbols appear throughout this manual and on your vehicle. Your safety is involved when these words and symbols are used. Become familiar with their meanings before reading the manual.

#### DANGER

DANGER indicates a hazardous situation which, if not avoided, WILL result in death or serious injury.

#### WARNING

WARNING indicates a hazardous situation which, if not avoided, COULD result in death or serious injury.

#### CAUTION

CAUTION indicates a hazardous situation which, if not avoided, COULD result in minor to moderate injury.

#### NOTICE

NOTICE provides key information by clarifying instructions.

#### IMPORTANT

IMPORTANT provides key reminders during disassembly, assembly, and inspection of components.

The Prohibition Safety Sign indicates an action NOT to take in order to avoid a hazard.



The Mandatory Action Sign indicates an action that NEEDS to be taken to avoid a hazard.



## VEHICLE IDENTIFICATION NUMBERS

Record your vehicle's identification numbers and key number in the spaces provided. Remove the spare key and store it in a safe place. An ignition key can be duplicated only by ordering a POLARIS key blank (using your key number) and mating it with one of your existing keys. The ignition switch must be replaced if all keys are lost.

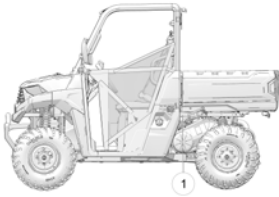

① Vehicle Identification Number (VIN)

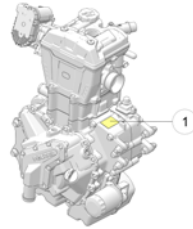

② Engine Serial Number

Vehicle Model Number:	
Vehicle Identification Number (VIN):	
Engine Serial Number:	
Key Number	

## INTRODUCTION

---

### NEAR-FIELD COMMUNICATION (NFC) (IF EQUIPPED)

Some Polaris vehicles come equipped with a near-field communication (NFC) chip. The NFC chip is embedded in the Polaris emblem located at the front of the vehicle and seamlessly connects you to a digital platform of vehicle information and tools. See your dealer for more information.

#### IMPORTANT

Not all devices are equipped with an NFC reader. Additionally, some devices require third party applications to access NFC content. For questions regarding the NFC reader on your device, refer to the device's user manual.

On models equipped with NFC, place your smartphone directly over the Polaris emblem to do the following:

- View vehicle specific information
- Access your Polaris Garage
- Download and view the owner's manual
- View accessory instructions
- Watch helpful videos
- Access warranty information
- Check for service notifications



### RIDE COMMAND WITH NFC

Additional NFC features are available when using the Ride Command mobile app. To access these features, do the following:

1. Download the Ride Command mobile app from the Apple App Store® or Google Play® store.
2. Create or log in to an existing account.
3. From the Ride Command mobile app home screen, select **Add Vehicle**.
4. On the vehicle, tap the NFC-enabled badge with the phone to scan the vehicle.
5. Confirm information, name your vehicle, and tap add to garage.

### SYSTEM REQUIREMENTS

Refer to device manufacturer's instructions to verify NFC read capability, and/or NFC-capable add-ons.

---

## SAFETY

### OWNER REQUIREMENTS

**Improper use, maintenance, or modification of this vehicle can lead to serious injury or death.**

**Require proper use of your vehicle.** Do not allow anyone to operate your vehicle or ride as a passenger unless they are properly instructed and you are sure they are willing to ride responsibly. To prevent unauthorized use, always remove the ignition key when the vehicle is not in use.



**Any modifications or installation of non-POLARIS-approved accessories could increase the risk of injury.** While you may find aftermarket products similar in design and quality to POLARIS accessories, recognize that some aftermarket accessories or modifications are not suitable because of potential safety hazards to you or others. It is never appropriate to install any additional seating.

Check with the manufacturer to determine any potential effect of a modification or accessory on the safe use of your vehicle. You are responsible for injuries related to modifications to the vehicle. Modifications or accessories may:

- Damage machine components - especially modifications that increase speed or power.
- Make the vehicle less stable at higher speeds.
- Add weight, reducing the amount of cargo and total weight you can carry, and raise the vehicle's center of gravity.
- Overload the vehicle's electrical system capacity. Blowing a fuse may cause a loss of lights or engine power.
- Reduce the effectiveness of occupant protection systems, including the seatbelts and the Rollover Protective Structure (ROPS).
- Make it illegal to own or operate your vehicle. POLARIS-authorized spark arresters, mufflers, and emissions control components are mandatory for ownership or operation in many areas.
- Void your warranty.

**The vehicle ROPS, when used with the seat belts and doors, provides a structure to help protect occupants.** The structure will not protect occupants in all rollovers or accidents.

For more information about safety, contact an authorized dealer or visit the Polaris website at [www.polaris.com](http://www.polaris.com).

### DRIVER AND PASSENGER QUALIFICATIONS

**Make sure operators are 16 or older with a valid driver's license.** Just because a teenager has a license does not mean that they will make good judgments about driving and avoid risk taking.

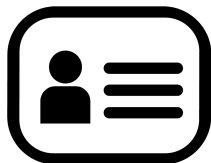

POLARIS recommends that you supervise younger drivers. Set rules and put limits on how, when, and where they are allowed to use this vehicle. For example, young drivers may need to have an adult in the vehicle with them and not be allowed to drive with their friends in the vehicle.

**Make sure all riders fit the vehicle.** Be sure that the driver and all passengers are able to:

- sit with their backs against their seat,
- adjust the seat belt to fit properly,
- have both feet flat on the floor, and
- have both hands on the steering wheel or on a passenger hand hold.

**Do not allow children who need child safety seats or booster seats to ride in the vehicle.** The vehicle is not designed to restrain automotive child safety seats.

**You are responsible for your passengers.** Be sure passengers are seated properly, belted, holding the passenger hand hold, and ready to brace. Unrestrained riders can fall out or be thrown around and from a moving vehicle.

**Every person must be properly seated and belted in their own seat.** Two people should never be belted into a single seat belt. People belted together can crash into one another in a collision and be seriously injured. Never carry passengers in the cargo bed as they could be thrown against or out of the vehicle or come into contact with moving parts.

**Do not let people drive or ride after using alcohol or drugs.**

## PREPARE VEHICLE FOR THE RIDE

**Before starting off, always perform the Pre-Ride Inspection.** Failure to inspect and verify that the vehicle is in safe operating condition increases the risk of an accident, which can lead to serious injury or death.



ITEM	REMARK	REFERENCE
Brake Fluid	Ensure proper level and condition	page 118
Front and rear suspension	Inspect	—
Steering	Ensure free operation	page 119
Tires	Inspect condition and pressure	page page 121
Wheels/Lug Nuts	Inspect, ensure fastener tightness	page 121
Fuel and oil	Ensure proper levels and condition	page 87
Coolant	Ensure proper level and condition	page 100
Indicator lights/switches	Ensure proper operation	page 38 page 47
Air Filter	Inspect, replace as needed	page 115
Engine intake pre-filter	Inspect, clean	—
PVT intake pre-filter	Inspect, clean	—
Headlights	Check operation	—
Brake lights/taillights	Check operation	—
Seat Latches (5 Passenger Models)	Ensure rear seat is secured.	page 42

## SAFETY

ITEM	REMARK	REFERENCE
Seat Belts	Check length of belt for damage, check latches for proper operation.	page 41
Exhaust	Inspect spark arrester and clean if needed.	page 79
Vehicle Debris	Remove grass, leaves, and other flammable material or debris, especially near the exhaust system.	-
Lock adjustable steering wheel	Do not adjust the steering wheel while the vehicle is moving.	-
Alternator Belt (if equipped)	Inspect for cracks, damage. Replace, if necessary.	-



**Improper tire maintenance** can lead to loss of control and an accident, which could result in serious injury or death. To reduce your risk of injury:

- Maintain POLARIS recommended tire pressure. Check pressure before operating. Even if your vehicle has only been driven a short distance, the tire pressure readings can become higher.
- Make sure tire pressures match the specifications listed in the table below.
- Only use the size and type of tires specified for this vehicle.
- Do not operate your vehicle with worn or damaged tires.
- Always follow your tire manufacturer's instructions for maintenance.

MEASUREMENT	SPECIFICATION
Maximum Cargo Box Load	500 lbs (226 kg)
Tire Pressure in PSI (kPa) SP 570 Models Only	Front: 10 PSI (69 kPa) Rear: 10 PSI (69 kPa)
Tire Pressure in PSI (kPa) SP 570 Premium Models Only	Premium Models Front: 10 PSI (69 kPa) Rear: 10 PSI (69 kPa)
Tire Pressure in PSI (kPa) SP 570 Northstar Models Only	Northstar Models Front: 10 PSI (69 kPa) Rear: 10 PSI (69 kPa)
Tire Pressure in PSI (kPa) Crew SP 570 Models Only	Front: 16 PSI (110 kPa) Rear: 16 PSI (110 kPa)
Tire Pressure in PSI (kPa) Crew SP 570 Premium Models Only	Premium Models Front: 16 PSI (110 kPa) Rear: 16 PSI (110 kPa)
Tire Pressure in PSI (kPa) Crew SP 570 Northstar Models Only	Northstar Models Front: 16 PSI (110 kPa) Rear: 16 PSI (110 kPa)
Maximum Weight Capacity Includes weight of operator, passenger, cargo, and accessories	SP 570 1000 lbs (454 kg) SP 570 Premium 925 lbs (420 kg) SP 570 Northstar 700 lbs (318 kg)

## SAFETY

Maximum Weight Capacity, Crew Models Includes weight of operator, passenger, cargo, and accessories	Crew SP 570 1225 lbs (510 kg) Crew SP 570 Premium 1100 lbs (499 kg) Crew SP 570 Northstar 750 lbs (340 kg)
--	---

### PREPARE YOURSELF, PASSENGERS, AND CARGO FOR THE RIDE

**Wear an approved helmet.** Riding in this vehicle without wearing an approved helmet increases the risk of serious injury. For example, a helmet reduces your risk of injury from head strikes with the vehicle or other objects even if there is no crash.

Approved helmets in the USA and Canada bear a U.S. Department of Transportation (DOT) label. Approved helmets in Europe, Asia, and Oceania bear the ECE 22.05 label. The ECE mark consists of a circle surrounding the letter E, followed by the distinguishing number of the country which has granted approval. The approval number and serial number will also be displayed on the label.



**Use shatterproof goggles or a shatterproof helmet face shield.** Such protective eyewear may reduce the risk of foreign material getting in your eyes and help prevent loss of vision.

POLARIS recommends wearing approved Personal Protective Equipment (PPE) that have markings indicating they are designed to standards such as:

- VESC 8
- V-8
- Z87.1
- CE



**Additional protective clothing and gear** that may be appropriate for your riding conditions includes:

- Always wear shoes when operating. Consider wearing sturdy over-the-ankle boots suitable for the terrain you will be riding in.
- Full-finger gloves can protect against wind, sun, cold, and objects. Choose gloves that fit snugly and allow fingers to move freely and grip on the steering wheel or hand holds.
- Consider long sleeves and long pants to help protect arms and legs.
- Long-term exposure to wind and engine noise can cause permanent hearing loss. Properly worn hearing protective devices such as earplugs can help prevent hearing loss. Check local laws or the rules of the riding area you are in before wearing hearing protection to make sure its use is permitted.

**Always stay completely inside the vehicle and hold the steering wheel or hand holds.** Body parts outside of the vehicle can be struck by passing objects or crushed during a rollover. Do not put any part of your body outside of the vehicle for any reason. Do not hold onto the ROPS frame or put any part of your body on the door.

Riding in this vehicle without closed and latched cab doors increases the risk of serious injury or death in the event of an accident or rollover. Always make sure all cab doors are closed and latched while riding in this vehicle.

**Be sure riders pay attention and plan ahead.** If you think or feel the vehicle may tip or roll, reduce your risk of injury:

- Keep a firm grip on the steering wheel or hand holds and brace yourself.
- Do not put any part of your body outside of the vehicle for any reason.

**This vehicle is not designed to carry unrestrained pets.** An unrestrained pet can be thrown about and injure riders, even during normal operation. When transporting pets, use a pet crate suitable for off-road use that is secured to the vehicle.

**Fuels such as gasoline can be extremely flammable.** To reduce the risk of serious injury or death, never carry fuel or other flammable liquids on this vehicle. Rollovers, crashes, rough riding, or changes in elevation or temperature may lead to fuel spilling or vapor release from portable containers. Hot vehicle parts can cause fires, even after the engine has been turned off.

**Never exceed vehicle weight capacities.** The vehicle's maximum weight capacity varies depending on model. The cargo box can support up to 500 lbs. (226 kg) of that total. When more rider weight is added, cargo weight may need to be eliminated to stay under the limit. Overloading the vehicle or carrying cargo improperly will cause changes in stability and handling, which could cause loss of control or an accident.

## SAFETY

---

**Secure cargo in the cargo box as far forward, centered and as low as possible.** When cargo cannot be positioned and secured in this way, operate with extra caution. Unsecured cargo can strike and injure riders, affect vehicle handling, and result in loss of control.

**The weight of riders and cargo changes vehicle braking, handling, and stability.** To avoid loss of control, turn gradually, operate at slower speeds, and avoid rougher or steeper terrain.

## DRIVING GUIDELINES

**Drive Responsibly.** This vehicle has higher ground clearance and other features to handle rugged terrain. It can be overturned in situations where some other vehicles may not. Abrupt maneuvers or aggressive driving, even on flat, open areas, can cause loss of control, rollovers, severe injury or death. To avoid loss of control and rollovers:



- Avoid abrupt maneuvers, sideways sliding, skidding, or fishtailing, and never do donuts.
- Slow down before entering turn.
- Avoid hard acceleration when turning, even from a stop.

### High speed off-road operation

Driving off-road vehicles to test the limits of your skills or abilities can be very dangerous to you, passengers, and bystanders. Basic skills for driving a car, ATV, or other off-road vehicles do not equip drivers to safely attempt high speed off-road operation. Develop your skill gradually through training, practice, and experience with the various driving modes of this vehicle and the terrain in which you are operating. Always do a low speed reconnaissance run (prerun) to become aware of anything you may encounter.

High speed off-road operation can lead to loss of control, crashes, or hard landings that can seriously injure occupants (even without rolling the vehicle or damaging it).

If you plan on using the vehicle for high speed, off-road competition, additional safety equipment may be necessary. Check the rules that apply to your competition.

**Do not go over jumps — going airborne can lead to serious injury or death.**

Going airborne can cause loss of control, rollovers, or crashing into the ground and may damage the vehicle. Even without crashing, landings can be hard enough to cause any vehicle suspension to fully compress (e.g., bottom out). Serious injuries, including spinal injuries, can occur even if riders are properly harnessed, wearing helmets and the vehicle is not damaged and remains upright.

You may encounter slopes, "jumps", or other terrain features that could send the vehicle airborne, depending on your speed. These may be defectively designed, poorly maintained, or not suitable for this vehicle. Slow down, use extra care, and avoid going airborne. Never take this vehicle over jumps.

Watching someone else go over a jump or go airborne does not mean you can safely do so. Polaris cannot determine whether any jump you may encounter is appropriate for this vehicle. Any jump, even a small one, could be poorly maintained, designed, or not suitable for this vehicle and may cause serious injury or death.

**Plan for hills, rough terrain, ruts, and other changes in traction and terrain.**

Proceed slowly and with extra care on unfamiliar terrain. Avoid paved surfaces. Sudden changes in terrain such as holes, depressions, banks, softer or harder ground, or other irregularities may cause loss of control or rollover. Give yourself time to react to rocks, bumps, or holes that may be hard to see. Operating in deep snow or tall grass may make it harder to see obstacles.

If you cannot go around an obstacle, such as a fallen tree or a ditch, stop the vehicle in a safe place. Get out to inspect the area thoroughly. Look from both your approach side and exit side. If you are reasonably confident you can continue safely, choose the path that will allow you to go straight over the obstacle to minimize the vehicle tipping sideways. Go only fast enough to maintain your momentum, but still give yourself plenty of time to react to changes in conditions. If there is any question about your ability to maneuver safely over the obstacle, you should turn around if the ground is flat and you have the room, or back up until you find a less difficult path.

Abrupt application of the accelerator pedal can cause the tires to lose traction, reducing control of the vehicle and increasing the possibility of an accident, especially while on sloped terrain or while crossing obstacles such as rocks or logs.

## SAFETY

---

**Avoid Operating on Public Roads (Paved or Otherwise).** This vehicle does not have highway safety features that on-road vehicles may have (air bags, anti-lock brakes, stability control, etc.). If another vehicle collides with you, the likelihood of a serious injury or death may be greater. Also, you may not be able to avoid a crash or rollover if you make sudden or abrupt maneuvers such as swerving or emergency braking.

While it may be legal to drive on some public roads, it is recommended that you avoid on-road operation. If you must drive on-road, drive slowly and defensively. Use extra care. You may also need to make vehicle modifications to comply with state or local laws. In addition, refer to tire manufacturer's instructions or limitations for on-road operation, including speed limits and premature tire wear.

**Improperly operating on hills can cause loss of control, rollover, or accident,** which can lead to serious injury or death. Use extra care when operating on hills. Plan for rough terrain, ruts, and other changes in traction and terrain.

### **Driving up hills**

Check the terrain before ascending a hill and make sure it is not too slippery or loose. Engage all-wheel drive for hills. Drive straight uphill, keeping speed and throttle steady. Avoid steep hills which can cause the vehicle to overturn.

### **Recovering from stalling on a hill**

If the vehicle loses forward speed, apply the brakes gradually and stop. Do not attempt to turn the vehicle around. Instead, shift to reverse and allow the vehicle to slowly roll straight downhill. Apply light brake pressure to control speed.

### **Overtopping a hill**

Slow down when you reach the crest of a hill. Never blindly go over the crest of a hill or a drop off at high speed. An obstacle, a sharp drop, or another vehicle or person could be on the other side of the hill.

### **Driving down hills**

Check the terrain before descending a hill and make sure it is not too slippery or loose. Engage all-wheel drive and proceed slowly, applying the brakes lightly. Never descend a hill with the transmission in neutral or if the engine is turned off.

### **Avoid side hilling (riding across slopes)**

If unavoidable, proceed slowly and with extra caution. Avoid obstacles and changes in terrain that could cause the vehicle to tip or slide. If it feels like the vehicle begins to tip or slide, immediately turn downhill.

### **Riding near wooded areas or brush**

Use extra caution when operating near trees, particularly when operating on narrow trails. Tree branches or brush can be driven into the cab striking or stabbing occupants.

**Riding in snow**

Always keep the brake and accelerator pedals free of snow and ice. Apply the brakes frequently to prevent ice or snow accumulation on the brake pads which can reduce brake performance.

**Riding on ice**

Never operate the vehicle on a frozen body of water unless you have verified that the ice can support the weight of the vehicle. Severe injury or death can result if the vehicle falls through the ice.

**Riding in water / Falling into water**

Operating through deep or fast-flowing water can cause loss of traction, loss of control, overturning, or being swept away in water. You can be seriously injured or killed from entrapment and drowning. Never operate the vehicle in fast-flowing water or in water that exceeds the floor level of the vehicle. Avoid sharp drop-offs and large rocks. Choose a path that provides an entrance and exit point with gradual inclines. Wet brakes may have reduced stopping ability. After leaving water, test the brakes. Apply them lightly several times while driving slowly. The friction will help dry out the pads.

**Riding on sand dunes**

Use extra caution when operating on or near dunes. Be alert for changes in terrain. Never blindly go over the crest of a hill or a drop-off at high speed. An obstacle, a sharp drop, or another vehicle or a person could be on the other side of the hill.

**Riding in low-visibility conditions**

Use extra caution and drive slowly in conditions of reduced visibility such as fog, rain, and darkness.

**Plan ahead to avoid the need for evasive maneuvers, such as swerving.**

Hitting an obstacle — including wildlife — you are not ready for can be dangerous. Choosing to swerve instead can be even more dangerous because it can lead to loss of control, rollover, or collisions.

When operating in areas with possibility of wildlife appearing in your path, plan ahead to avoid swerving for animals if doing so could result in collisions or rollovers. Go slowly or avoid driving during seasons or times of day when animals such as deer are more likely to cross your path without warning.

**Avoid Collisions With Other Vehicles**

When following another vehicle or operating in the same area as others, keep a safe distance to avoid collisions. Allow extra space when sight distances are limited by dust, snow, curves, hills, or other conditions. Plan ahead to avoid having to swerve or leave the trail to avoid a collision.

## SAFETY

---

On trails, be prepared to make space for other vehicles to pass. If you need to stop on a trail, move your vehicle to the edge of the path to allow others to pass safely.

### **Correct a skid by turning the steering wheel in the direction of the skid.**

Never apply the brakes during a skid.

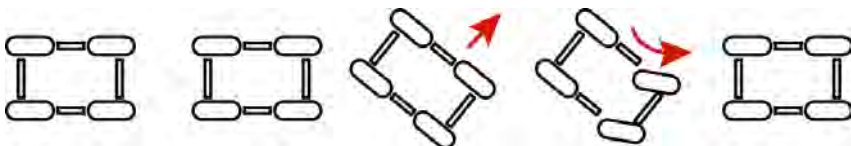

If the vehicle begins to slide downhill or you feel it may tip, turn downhill immediately and stop. Maneuver slowly and carefully until you can drive straight downhill.

### **Do not continue driving if your vehicle may be damaged or if you were in a crash or rollover.**

Operating the vehicle while damaged or after a crash or rollover can cause loss of control, rollover, or accident, which can lead to serious injury or death. If you cannot safely transport the vehicle on your own, contact a recovery and towing service.

After any crash, rollover, or other accident, have a POLARIS dealer inspect the vehicle for possible damage, including seat belts, ROPS, brakes, suspension, and steering systems.

Be prepared in case your vehicle becomes damaged or disabled, especially in remote areas. Consider in advance how to get help and stay safe until it arrives whenever you ride.



**There is a recovery tow loop ① at the front and back of the vehicle to attach a winch or strap.**

Use these loops to recover this vehicle if it is stuck, to pull it onto a tow truck, trailer, or to use this vehicle to recover another vehicle. These loops are for emergency recovery only and are not for towing vehicles to another location.

Improper recovery may lead to loss of control or vehicle damage. Only attach straps to specified locations. Do not attach to any other point on the vehicle. Only recover a vehicle of equal or lesser size and weight. When recovering a disabled vehicle, place the disabled vehicle's transmission in neutral. Do not move a disabled POLARIS vehicle faster than 10 mph (16 km/h).

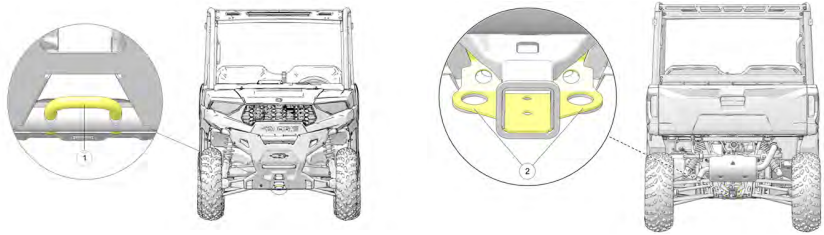

**Operating, Idling, Or Parking Near Combustible Materials**

Engine, exhaust, and other vehicle components can be very hot during and after use. Do not idle or park the vehicle over anything that could contact the exhaust system and catch on fire, such as tall grass, weeds, brush, leaves, debris, or other tall ground cover. Do not let mud, grass, or other debris accumulate on the engine or exhaust system. Inspect and remove as needed.

**Vehicle rollaway can cause serious injury or death.** This vehicle can roll whenever the gear selector is not in the PARK (P) position. Always shift to PARK (P) when stopping the engine or leaving the vehicle. When leaving the vehicle on an incline is unavoidable, use extra care. If leaving the vehicle unattended, block the rear wheels on the downhill side and keep children, pets, and others away from the gear selector.

**Before shifting into reverse, use extra care to make sure the area is clear of people or obstacles.** When it's safe to proceed, back slowly.

## SAFETY

---

**After operation, inspect the vehicle for damage and debris** to make sure the vehicle can be safely stored and operated again. Some things to inspect include:

- Debris that could catch fire, such as mud/grass near the engine or exhaust system
- Damage to the suspension, steering, or any other part of the vehicle
- Tire condition, such as tread and sidewall damage
- Shock absorber assembly condition

Be sure to have any issues checked and problems fixed before operating again.

**All engine exhaust contains carbon monoxide**, a deadly gas. Breathing carbon monoxide can cause headaches, dizziness, drowsiness, nausea, confusion, and eventually death. Carbon monoxide is a colorless, odorless, tasteless gas which may be present even if you do not see or smell any engine exhaust. Deadly levels of carbon monoxide can collect rapidly, and you can quickly be overcome and unable to save yourself. Also, deadly levels of carbon monoxide can linger for hours or days in enclosed or poorly ventilated areas. If you experience any symptoms of carbon monoxide poisoning, leave the area immediately, get fresh air, and **SEEK MEDICAL TREATMENT**.

- Do not run engine indoors. Even if you try to ventilate engine exhaust with fans or open windows and doors, carbon monoxide can rapidly reach dangerous levels.
- Do not run engine in poorly ventilated or partially enclosed areas such as barns, garages, or carports. If you start a vehicle in one of these, drive it out and close the door as soon as possible. If you drive it into one of these, turn it off as soon as possible.
- Do not run engine outdoors where engine exhaust can be drawn into a building through openings such as windows and doors.

## SAFETY LABELS AND LOCATIONS

Warning labels have been placed on the vehicle for your protection. Read and follow the instructions of the labels on the vehicle carefully. If any of the labels depicted in this manual differ from the labels on your vehicle, always read and follow the instructions of the labels *on the vehicle*.

If any label becomes illegible or comes off, contact your POLARIS dealer to purchase a replacement. Replacement *safety* labels are provided by POLARIS at no charge. The part number is printed on the label.

### BELT WARNING

The Belt Warning label is located on the clutch cover.

#### **WARNING**

Improper service or maintenance of this PVT system can result in vehicle damage, SEVERE INJURY or DEATH.

Always look for and remove debris inside and around clutch and vent system when replacing belt.

Read owner's manual or see authorized Polaris dealer.

Part number: 7177469 (English),  
7177469-F (French Canadian)

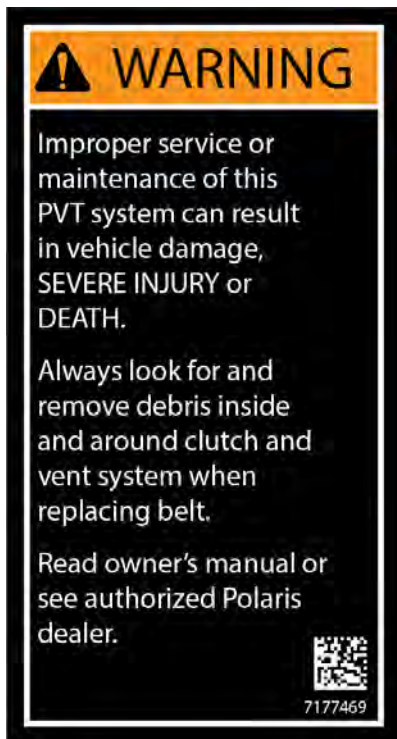

# SAFETY

## PROPER USE WARNING

The Proper Use Warning label is located on the ROPS.

### WARNING

Improper vehicle use can result in SEVERE INJURY or DEATH

### WARNING

#### Drive Responsibly

Avoid loss of control and rollovers:

- Avoid abrupt maneuvers, sideways sliding, skidding, or fishtailing, and never do donuts.
- Avoid hard acceleration when turning, even from a stop.
- Plan for hills, rough terrain, ruts, and other changes in traction and terrain. Avoid paved surfaces.
- Avoid side hilling (riding across slopes).

#### Require Proper Use of Your Vehicle

Do your part to prevent injuries:

- Do not allow careless or reckless driving.
- Make sure operators are 16 or older with a valid driver's license.
- Do not let people drive or ride after using alcohol or drugs.
- Do not allow operation on public roads (unless designated for off-highway vehicle access) — collisions with cars and trucks can occur.
- Do not exceed seating capacity: 2 occupants.



The image shows a warning label with a black background and orange border. At the top, it features a warning symbol and the word "WARNING" in large, bold, white letters. Below this, the text "Improper vehicle use can result in SEVERE INJURY or DEATH" is written in white. The label is divided into two main sections. The left section is titled "Drive Responsibly" and lists several safety instructions: "Avoid loss of control and rollovers:", "• Avoid abrupt maneuvers, sideways sliding, skidding, or fishtailing, and never do donuts.", "• Slow down before entering a turn.", "• Avoid hard acceleration when turning, even from a stop.", "• Plan for hills, rough terrain, ruts, and other changes in traction and terrain. Avoid paved surfaces.", and "• Avoid side hilling (riding across slopes)". To the right of this text is an illustration of a vehicle rolling over, with a speech bubble that says "Rollovers have caused severe injuries and death, even on flat, open areas." The right section is titled "Require Proper Use of Your Vehicle" and lists instructions: "Do your part to prevent injuries:", "• Do not allow careless or reckless driving.", "• Make sure operators are 16 or older with a valid driver's license.", "• Do not let people drive or ride after using alcohol or drugs.", "• Do not allow operation on public roads (unless designated for off-highway vehicle access) - collisions with cars and trucks can occur.", and "• Do not exceed seating capacity: 2 occupants." To the right of this text is a red circle with a diagonal slash over the number "16", with the words "DRIVER UNDER" above it. In the bottom right corner, there is a QR code and the number "7300524".

Part Number: 7300524 (English), 7300524–F (French Canadian)

## PROPER USE WARNING (CREW MODELS ONLY)

The Proper Use Warning label is located on the ROPS.

### WARNING

Improper vehicle use can result in SEVERE INJURY or DEATH

### WARNING

#### Drive Responsibly

Avoid loss of control and rollovers:

- Avoid abrupt maneuvers, sideways sliding, skidding, or fishtailing, and never do donuts.
- Avoid hard acceleration when turning, even from a stop.
- Plan for hills, rough terrain, ruts, and other changes in traction and terrain. Avoid paved surfaces.
- Avoid side hilling (riding across slopes).

#### Require Proper Use of Your Vehicle

Do your part to prevent injuries:

- Do not allow careless or reckless driving.
- Make sure operators are 16 or older with a valid driver's license.
- Do not let people drive or ride after using alcohol or drugs.
- Do not allow operation on public roads (unless designated for off-highway vehicle access) — collisions with cars and trucks can occur.
- Do not exceed seating capacity: 4 occupants.



Part Number: 7300525 (English), 7300525-F (French Canadian)

# SAFETY

## PASSENGER/ TIRE PRESSURE WARNING

The Passenger/ Tire Pressure Warning is located on the cargo box.

### ⚠ WARNING

- Never carry passengers in cargo box.
- Passengers can be thrown off. This can cause serious injury or death.
- If total payload is greater than 500 lbs, the vehicle must be operated in LOW range.

### ⚠ WARNING

#### IMPROPER TIRE PRESSURE OR OVERLOADING CAN CAUSE LOSS OF CONTROL RESULTING IN SERIOUS INJURY OR DEATH.

- Reduce speed and allow greater distance for braking when carrying cargo.
- Overloading or carrying tall, off-center, or unsecured loads will increase your risk of losing control. Loads should be centered and carried as low as possible in box.
- For stability on rough or hilly terrain, reduce speed and cargo.

**⚠ WARNING**



• Never carry passengers in cargo box.

• Passengers can be thrown off. This can cause serious injury or death.

• If total payload is greater than 500 lbs, the vehicle must be operated in LOW range.

---

**⚠ WARNING**

**IMPROPER TIRE PRESSURE OR OVERLOADING CAN CAUSE LOSS OF CONTROL RESULTING IN SERIOUS INJURY OR DEATH.**

- Reduce speed and allow greater distance for braking when carrying cargo.
- Overloading or carrying tall, off-center, or unsecured loads will increase your risk of losing control. Loads should be centered and carried as low as possible in box.
- For stability on rough or hilly terrain, reduce speed and cargo.

RANGER	RANGER SP 570	RANGER SP 570 PREMIUM	RANGER SP 570 NorthStar Edition
MAXIMUM CARGO BOX LOAD	500 lbs (226 kg)	500 lbs (226 kg)	500 lbs (226 kg)
TIRE PRESSURE (IN PSI (KPa))	FRONT 10 (69) REAR 10 (69)	FRONT 10 (69) REAR 10 (69)	FRONT 10 (69) REAR 10 (69)
MAXIMUM WEIGHT CAPACITY (INCLUDES WEIGHT OF OPERATOR, PASSENGER, CARGO, AND ACCESSORIES)	1000 lbs (454 kg)	973 lbs (440 kg)	900 lbs (408 kg)

Read Operation & Maintenance Manual for more detailed loading information.

RANGER CREW	RANGER CREW SP 570	RANGER CREW SP 570 PREMIUM	RANGER CREW SP 570 NorthStar Edition
MAXIMUM CARGO BOX LOAD	500 lbs (226 kg)	500 lbs (226 kg)	500 lbs (226 kg)
TIRE PRESSURE (IN PSI (KPa))	FRONT 16 (110) REAR 16 (110)	FRONT 16 (110) REAR 16 (110)	FRONT 16 (110) REAR 16 (110)
MAXIMUM WEIGHT CAPACITY (INCLUDES WEIGHT OF OPERATOR, PASSENGER, CARGO, AND ACCESSORIES)	1225 lbs (557 kg)	1191 lbs (539 kg)	700 lbs (316 kg)

Read Operation & Maintenance Manual for more detailed loading information.

Read Operation & Maintenance Manual for more detailed loading information.

RANGER	RANGER SP 570	RANGER SP 570 PREMIUM	RANGER SP 570 NORTHSTAR EDITION
MAXIMUM CARGO BOX LOAD	500 (226 kg)	500 (226 kg)	500 (226 kg)
TIRE PRESSURE IN PSI (KPa)	Front 10 (69) Rear 10 (69)	Front 10 (69) Rear 10 (69)	Front 10 (69) Rear 10 (69)

<b>RANGER</b>	<b>RANGER SP 570</b>	<b>RANGER SP 570 PREMIUM</b>	<b>RANGER SP 570 NORTHSTAR EDITION</b>
MAXIMUM WEIGHT CAPACITY INCLUDES WEIGHT OF OPERATOR, PASSENGER, CARGO, AND ACCESSORIES	1000 (454 kg)	925 (420 kg)	700 (318 kg)
Read Operation & Maintenance Manual for more detailed loading information.			

<b>RANGER CREW</b>	<b>RANGER CREW SP 570</b>	<b>RANGER CREW SP 570 PREMIUM</b>	<b>RANGER CREW SP 570 NORTHSTAR EDITION</b>
MAXIMUM CARGO BOX LOAD	500 (226 kg)	500 (226 kg)	500 (226 kg)
TIRE PRESSURE IN PSI (KPa)	Front 16 (110) Rear 16 (110)	Front 16 (110) Rear 16 (110)	Front 16 (110) Rear 16 (110)
MAXIMUM WEIGHT CAPACITY INCLUDES WEIGHT OF OPERATOR, PASSENGER, CARGO, AND ACCESSORIES	1225 (510 kg)	1100 (499 kg)	750 (340 kg)
Read Operation & Maintenance Manual for more detailed loading information.			

Part number: 7300521 (English), 7300521-F (French Canadian)

## SAFETY

### SEAT BELT/ DRIVER RESPONSIBLY WARNING

#### WARNING

Improper vehicle use can result in **SEVERE INJURY** or **DEATH**

#### Be Prepared

- Fasten seat belts.
- Wear an approved helmet and protective gear.
- **ALWAYS** use vehicle cab doors if equipped.
- Each rider must be able to sit with back against seat, feet flat on the floor, and hands on steering wheel or handholds. Stay completely inside the vehicle.

#### Be Sure Riders Pay Attention and Plan Ahead

If you think or feel the vehicle may tip or roll, reduce your risk to injury:

- Keep a firm grip on the steering wheel or handholds and brace yourself.
- Do not put any part of your body outside of the vehicle for any reason.

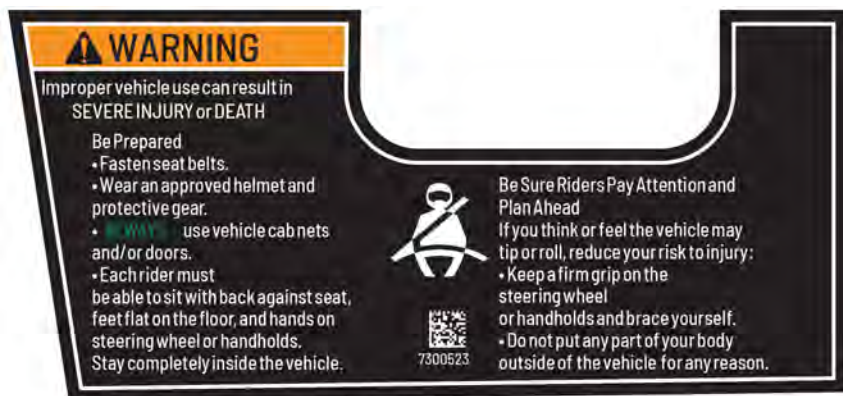

Part number: 7300523 (English), 7300523-F (French Canadian)



## MAXIMUM PAYLOAD WARNING

### ⚠ WARNING

The Maximum Payload Warning label is located on the cargo box.



<i>RANGER</i>	NEVER EXCEED	IF TOTAL PAYLOAD EXCEEDS
SP 570	30 mph (49 kph)	480 lbs (218 kg)
CREW SP 570	35 mph (56 kph)	750 lbs (340 kg)

### ⚠ CAUTION

To avoid transmission damage, shift only when the vehicle is stationary and at idle. When the vehicle is stopped, place shift in parked position.

Part number: 7300582 (English), 7300582-F (French Canadian)

## CLUTCH COVER WARNING

The Clutch Cover Warning label is located on the clutch cover.

### ⚠ WARNING

- Moving parts hazard under belt-clutch guard. To prevent serious injury, do not operate vehicle with guard removed
- Do not modify engine or clutch. Doing so can cause part failure, possible imbalance, and excessive engine RPM which can result in serious injury or death.

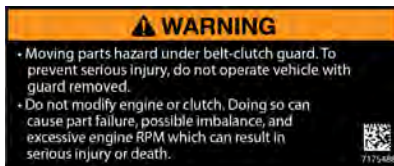

Part number: 7175488 (English),  
7175488-F (French Canadian)

## SAFETY

---

### FUEL TRANSPORT WARNING

The Fuel Transport Warning label is located in the cargo box.

#### WARNING

NEVER carry fuel or other flammable liquids on this vehicle

Failure to follow this instruction could lead to serious burn injuries or death.

Part number: 7186122 (English),  
7186122-F (French Canadian)



### AIR FILTER CAUTION

The Air Filter Caution label is located on the air filter housing.

#### CAUTION

Use a Polaris approved air filter. The use of a non-Polaris approved air filter may cause engine damage. Before installing filter, ensure there is no dirt or debris in the clean side of the intake tube. The air filter must be properly seated before the lid is reinstalled.

Please reference your owner's manual for additional information regarding air filter service.

Part Number 7195873 (English),  
7195873-F (French Canadian)

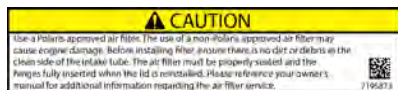

## FEATURES AND CONTROLS

### COMPONENT LOCATIONS

- ① ROPS (Roll Over Protection System)
- ② Headlight
- ③ Front Bumper/ Brush Guard
- ④ Tie Down Point
- ⑤ Radiator (behind removable grille)

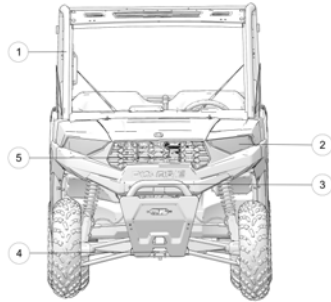

- ⑥ Cargo Box
- ⑦ Tailgate
- ⑧ Muffler (Spark Arrestor)
- ⑨ Cargo Box Lever
- ⑩ Fuel Cap

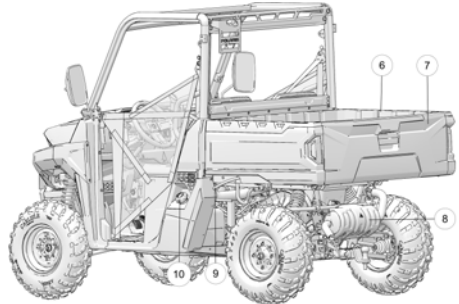

- ⑪ Seatbelt
- ⑫ Electrical Compartment (under seat)

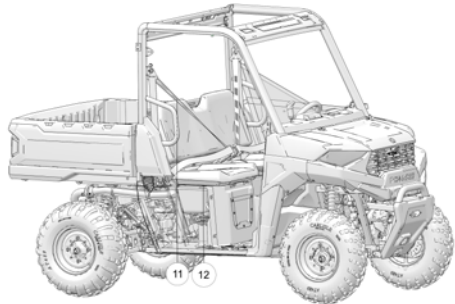

### CONSOLE

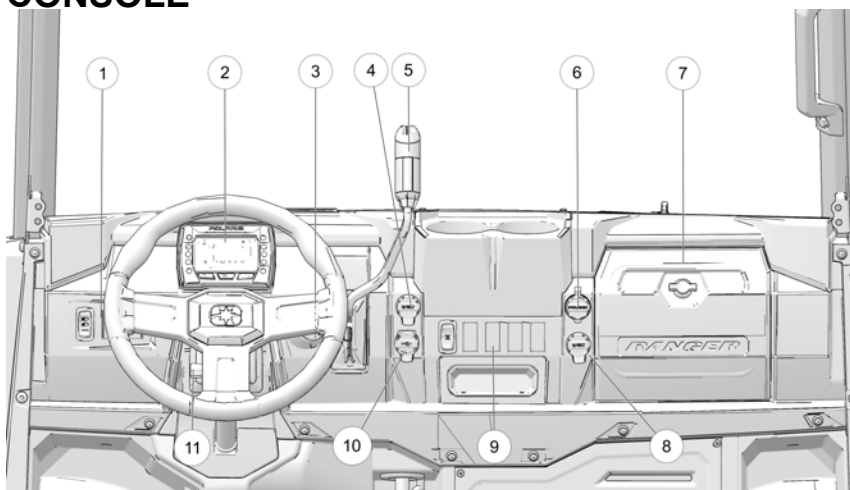

- |                                 |                                   |
|---------------------------------|-----------------------------------|
| ① Left Switch Panel             | ⑦ Storage Compartment             |
| ② Instrument Cluster            | ⑧ 12V Auxiliary Port              |
| ③ Ignition Switch               | ⑨ Right Switch Panel              |
| ④ 12V Auxiliary Port            | ⑩ USB Charging Port (if equipped) |
| ⑤ Gear Selector (Shifter)       | ⑪ Steering Wheel Adjustment Lever |
| ⑥ Battery Trickle Charging Port |                                   |

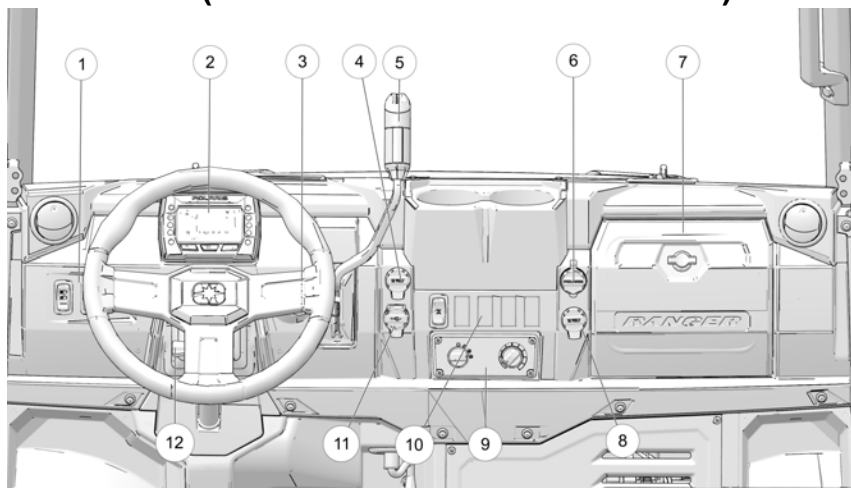
**CONSOLE (NORTHSTAR MODELS ONLY)**

- |                                   |                                   |
|-----------------------------------|-----------------------------------|
| ① Left Switch Panel               | ⑦ Storage Compartment             |
| ② Instrument Cluster              | ⑧ 12V Auxiliary Outlet            |
| ③ Ignition Switch                 | ⑨ Heater Controls (If Equipped)   |
| ④ 12V Auxiliary Outlet            | ⑩ Right Switch Panel              |
| ⑤ Gear Selector (Shifter)         | ⑪ USB Charging Port (if equipped) |
| ⑥ Battery Trickle Charging Outlet | ⑫ Steering Wheel Adjustment Lever |

**ADJUSTABLE STEERING WHEEL**

The steering wheel can be tilted upward or downward for rider preference.

Lift and hold the adjustment lever toward you while moving the steering wheel upward or downward. Release the lever when the steering wheel is at the desired position.

## FEATURES AND CONTROLS

---

### AUXILIARY OUTLET

The vehicle is equipped with 12-volt accessory outlets on the dash. Use the outlets to power an auxiliary light or other optional accessories or lights. For service, the dash outlet connection is under the dash.



### BATTERY TRICKLE-CHARGING OUTLET

The vehicle is equipped with a dedicated outlet for trickle-charging the battery during periods of extended inactivity.

If you do not drive the vehicle for more than TWO WEEKS, Polaris recommends using a BatteryMINDER® 2012 AGM - 2 AMP charger, which can be ordered through your dealer.

Polaris provides a charging accessory with your vehicle that allows easy connection to the battery through the Battery Trickle-Charging Outlet, located on the dash. While charging, place the charger outside of the vehicle and protect it from moisture.



### USB OUTLET

The vehicle is equipped with a dual USB outlet in the center console. The outlet consists of two USB terminals.



### GEAR SELECTOR

Low gear is the primary driving range for the *RANGER*. High gear is intended for use on hard-packed surfaces with light loads. Using high gear for heavy loads, hilly terrain or in wet, muddy conditions will increase the chance of drive belt burning. See the Drive Belt Wear/Burn section for details.

H: High Gear

L: Low Gear

N: Neutral

R: Reverse

P: Park

To shift gears, brake to a complete stop. When the engine is idling, move the lever to the desired gear.

#### NOTICE

Shifting gears with the engine speed above idle or while the vehicle is moving could cause transmission damage. Always shift when the vehicle is stationary and the engine is at idle.

#### TIP

Maintaining shift linkage adjustment is important to assure proper transmission function. See your dealer if you experience any shifting problems.

### **USING LOW GEAR**

Always shift into low gear for any of the following conditions.

## FEATURES AND CONTROLS

---

- Operating in rough terrain or over obstacles
- Loading the vehicle onto a trailer
- Towing heavy loads
- Driving frequently at low RPM or at ground speeds below 11 km/h (7 MPH)

## SWITCHES

### MODE BUTTON

The MODE button is located on the instrument cluster. Use the MODE button to toggle through mode options available in the instrument cluster.

### IGNITION SWITCH

The ignition switch ① is a four-position, key-operated switch. The key can be removed from the switch when it is in the OFF position.



### STANDARD MODELS

OFF	The engine is off. Electrical circuits are off.
SYSTEM ON	Electrical circuits are on. Electrical equipment can be used. Headlights are off.
ON	Electrical circuits are on. Electrical equipment can be used. Headlights are on.
START	Turn the key to the START position to engage the electric starter. The key returns to the ON position when released.

### PREMIUM MODELS

OFF	The engine is off. Electrical circuits are off.
ACCESSORY	The engine is off. Powers the gauge and terminal block. Check engine and steering warning indicators will appear on the gauge in this mode, but will turn off when the vehicle is started if no issues are present.



## FEATURES AND CONTROLS

SYSTEM ON	Electrical circuits are on. Electrical equipment can be used.
START	Turn the key to the START position to engage the electric starter. The key returns to the ON position when released.

### DRIVELINE MODE SWITCH

The Driveline Mode Switch has three positions: All Wheel Drive (AWD), Differential Lock/Two Wheel Drive (2WD) and Off (Turf Mode).

- ① **AWD:** Press the top of the switch to engage All Wheel Drive (AWD).
- ② **2WD:** Move the switch to the center position to lock the differential and operate in two wheel drive (2WD).
- ③ **TURF Mode:** Press the bottom of the switch for Turf Mode (unlocked differential power). In Turf Mode, the rear drive wheels operate independently depending on tire traction. This mode of operation is well suited to turf driving or when active traction is not needed.

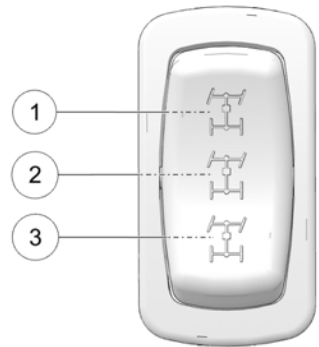

### THROTTLE PEDAL

Push the throttle pedal ① down to increase engine speed. Spring pressure returns the pedal to the rest position when released. Always check that the throttle pedal returns normally before starting the engine.

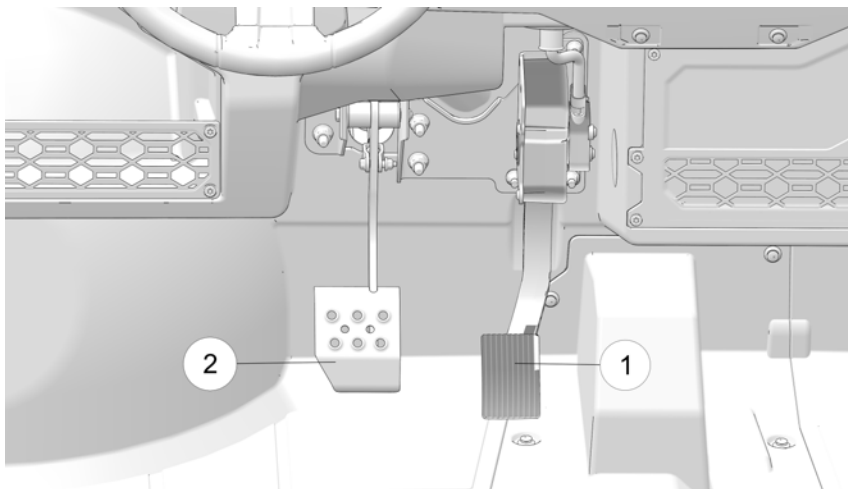

#### TIP

If the throttle pedal and brake pedal are applied simultaneously, engine power may be limited.

### BRAKE PEDAL

Depress the brake pedal ② to slow or stop the vehicle. Apply the brakes while starting the engine.

## SEAT

### SEAT BELTS

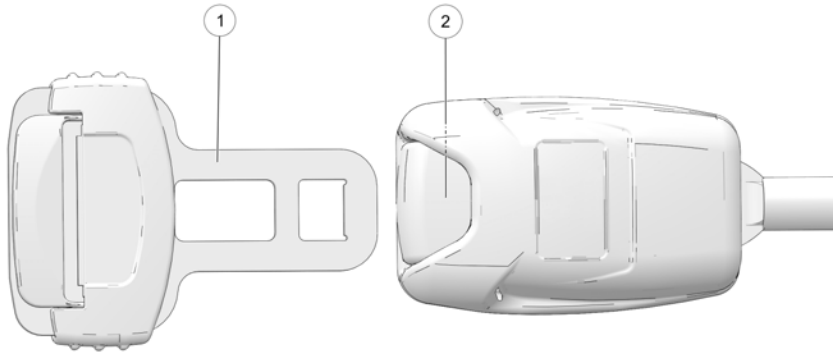

This vehicle is equipped with three-point lap and diagonal seat belts for the operator and passenger. Always make sure the seat belts are secured for all riders before operating. The driver's seat belt is equipped with a seat belt interlock. Vehicle speed will be limited to 15 MPH (24 km/h) if the seat belt is not secured.

The center of the seat is NOT equipped with a seat belt. Never allow a passenger to ride between the operator and passenger seats.

#### WARNING

Falling from a moving vehicle could result in serious injury or death. Always fasten your seat belt securely before operating or riding in the vehicle.

To wear the seat belt properly, follow this procedure:

1. For 3-point belts, pull the seat belt latch ① downward and across your chest toward the buckle at the inner edge of the seat. The belt should fit snugly across your hips and diagonally across your chest. Make sure the belt is not twisted.
2. Push the latch plate ① into the buckle ② until it clicks.
3. Release the strap, and pull to tighten.
4. To release the seat belt, press the square red button in the buckle's center.

## FEATURES AND CONTROLS

---

### SEAT BELT INSPECTION



Failure to perform regular inspection can reduce the effectiveness of the seat belt during a crash and could result in serious injury or death.

Inspect all seat belts for proper operation before each use of the vehicle.

1. Push the latch plate into the buckle until it clicks. The latch plate must slide smoothly into the buckle. A click indicates that it's securely latched.
2. Push the red release latch in the middle of the buckle to make sure it releases freely.
3. Pull each seat belt completely out and inspect the full length for any damage, including cuts, wear, fraying or stiffness. If any damage is found, or if the seat belt does not operate properly, have the seat belt system checked and/or replaced by an authorized dealer.
4. To clean dirt or debris from the seat belts, sponge the straps with mild soap and water. Do not use bleach, dye or household detergents. Rinse the entire length of the belt webbing. Use a garden hose to flush out the retractor and latch housings regularly.

### SEAT AND STORAGE COMPARTMENTS

The electrical compartment is located under the center rear-most seat. Never use this area for storage. Storage compartments are located under all other seats. Remove the storage bin under the right rear-most passenger seat to access the battery.

If your model is equipped with a storage console and cup holders located between the front seats, lift the console lid to access the storage compartment.

Pull the rear edge of a seat upward to release the latch pins from the grommets. Roll the seat forward to access the under-seat area. To completely remove a seat, roll the seat forward and lift the seat tabs from the seat base mounts.

Always make sure all seats are properly installed and securely latched before operating. Push down firmly on the rear of each seat until the latch pins are fully seated into the grommets.

### SEAT REMOVAL

To remove the seat:

1. Lift up on the back of the seat.
2. Detach the seat assembly from the seat hinges.
3. Remove the seat from the vehicle.

### ELECTRONIC POWER STEERING (IF EQUIPPED)

Electronic power steering (EPS) engages when the ignition key is turned to the ON position. EPS remains engaged whether the vehicle is moving or idle. To conserve battery power, the EPS will shut down 5 minutes after the engine is stopped if the key remains in the ON position. The EPS warning indicator will illuminate to indicate the EPS has shut down. Turn the key off and on to reset the unit. If the light remains on after starting the engine, the EPS system is inoperative. See your POLARIS dealer, or other qualified person, as soon as possible for repair. Continued operation could result in permanent damage to the EPS unit and increased steering effort.

### FUEL CAP

#### NOTICE

Never use fuel blends with more than 10% ethanol. Engine damage could occur.

The fuel tank filler cap ① is located on the right-hand side of the vehicle near the passenger seat. When refueling, always use either leaded or unleaded gasoline with a minimum pump octane number of 87 R+M/2 octane. Do not use fuel with ethanol content greater than 10 percent, such as E-85 fuel. Compatible fuels: E5 and E10

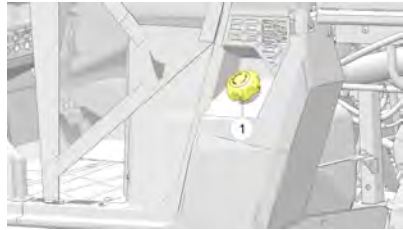

## FEATURES AND CONTROLS

---

### CAB NETS (IF EQUIPPED)

Riding in this vehicle without using the cab nets (or doors, if equipped) increases the risk of serious injury or death in the event of an accident or rollover. Cab nets (or doors) must be used by both operator and passengers at all times. Make sure all latches are secure before operating the vehicle.

Always inspect cab nets and latches for tightness, wear and damage before each use of the vehicle. Use the strap adjusters to tighten any loose straps. Promptly replace worn or damaged cab nets and latches with new cab nets and latches. Your POLARIS dealer can assist.

### SECURING THE NET

1. After entering the vehicle, connect the latch at the top edge of the net to the receiver latch mounted on the front frame.

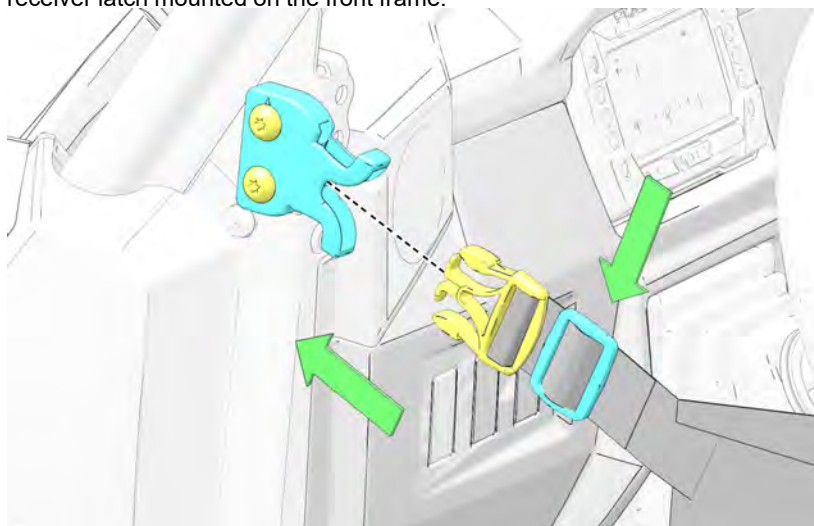

2. To adjust the net tension, slide the adjuster toward the rear of the vehicle. To loosen the net, slide the adjuster forward.

### OPENING THE NET

1. To exit the vehicle, release the top front latch.
2. Allow the net to hang freely outside the vehicle while dismounting.

### ROLLOVER PROTECTIVE STRUCTURE (ROPS)

The Rollover Protective Structure (ROPS) ① on this vehicle meets OSHA® 1928.53 rollover performance requirements. Always have your authorized POLARIS dealer thoroughly inspect the ROPS if it ever becomes damaged in any way.

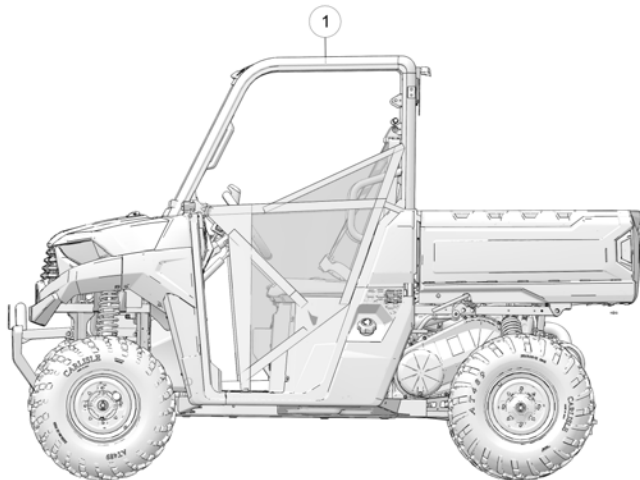

*No device can assure occupant protection in the event of a rollover. Always follow all safe operating practices outlined in this manual to avoid vehicle rollover.*

#### WARNING

Vehicle rollover could cause severe injury or death. Always avoid operating in a manner that could result in vehicle rollover.

### TRAILER HITCH BRACKET

This vehicle is equipped with a receiver hitch bracket for a trailer hitch. To avoid injury and property damage, always heed the warnings and towing capacities outlined on page 73.

# INSTRUMENT CLUSTER

## OVERVIEW

**NOTICE**

Features and telltales vary by model.

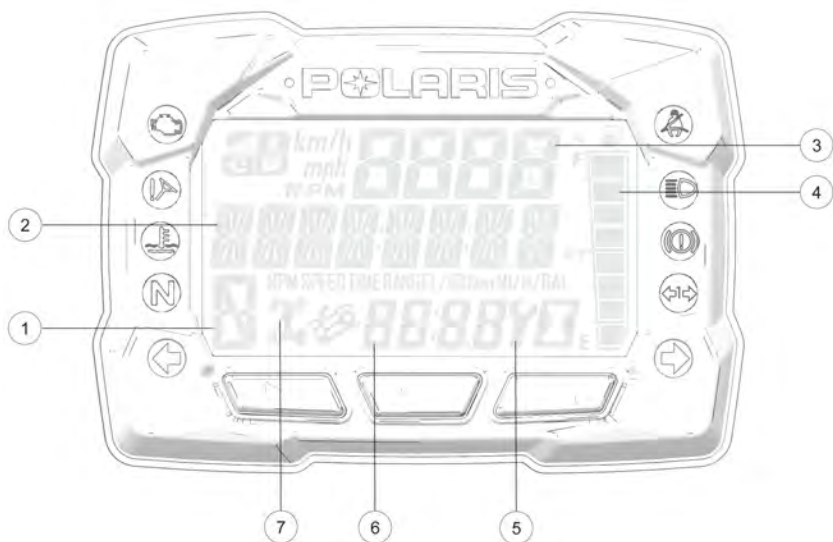





DISPLAY AREA	FUNCTION
① Gear Indicator	H = High Gear L = Low Gear N = Neutral R = Reverse Gear P = Park – = Gear Signal Error (or shifter between gears)
② Display Area 2	This area displays odometer, trip meter, trip meter 2, voltage, engine temperature, engine hour meter, programmable service hour interval, ground speed, or engine RPM.
③ Display Area 1	This area displays engine RPM, ground speed, or coolant temperature.
④ Fuel Gauge	The segments of the fuel gauge show the level of fuel in the fuel tank. When the last segment clears, a low fuel warning is activated. All segments including the fuel icon will flash. Refuel immediately.





## FEATURES AND CONTROLS

DISPLAY AREA	FUNCTION
⑤ Service Indicator	A flashing wrench symbol alerts the operator that the preset service interval has been reached. Your POLARIS dealer can provide scheduled maintenance.
⑥ Clock	The clock displays time in a 12-hour or 24-hour format.
⑦ Driveline Mode Indicator	Segments of the indicator illuminate based on driveline mode engaged.

## INDICATOR LAMPS

INDICATOR	ICON	FUNCTION
Check Engine		This indicator appears if a fault occurs. Do not operate the vehicle if this warning appears. Serious engine damage could result. Your authorized POLARIS dealer can assist.
EPS Warning (if equipped)		This indicator illuminates when a fault has occurred in the EPS system. Your authorized POLARIS dealer can assist. EPS operation is possible with key on/engine off for up to 5 minutes.
Engine Hot		This lamp illuminates to indicate an overheated engine. If the indicator flashes, a severe overheating condition exists.
Neutral		This lamp illuminates when the transmission is in neutral and the ignition key is in the ON position.
Helmet/Seat Belt		This lamp flashes for several seconds when the key is turned to the ON position. The lamp is a reminder to wear helmet and seat belt (if equipped) before operating.

## FEATURES AND CONTROLS

INDICATOR	ICON	FUNCTION
High Beam		This lamp illuminates when the headlamp switch is set to high beam.
Brake Failure (if equipped)		Lamp illuminates when Brake System (if Brake Failure Alarm is equipped) detects low fluid level in brake hydraulic system. Verify brake fluid in reservoir.

## DISPLAY AREA 1

Pressing the MODE button will change the information displayed in Area 1 ①.

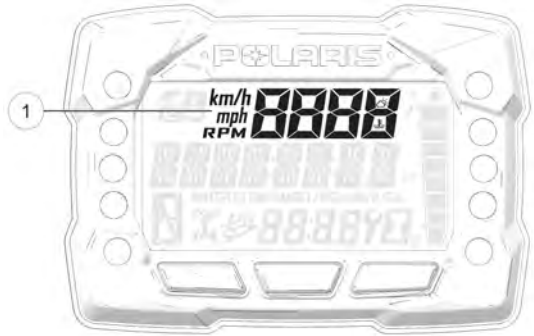

DISPLAY AREA 1	FUNCTION
Speed	The vehicle's speed will be displayed in mph, or km/h.
Engine Temperature	The vehicle's current engine temperature will be displayed.
RPM	The vehicle's RPM will be displayed.

## FEATURES AND CONTROLS

### DISPLAY AREA 2

Toggle the Up/Down buttons to change the information displayed in Area 2 ②.



DISPLAY AREA 2	FUNCTION
Odometer	The vehicle's odometer reading will be displayed.
Engine Temperature	The vehicle Engine Temperature will be displayed.
Trip 1	The vehicle Trip 1 mileage will be displayed.
Trip 2	The vehicle Trip 2 mileage will be displayed.
RPM	The vehicle RPM will be displayed.
Voltage	The vehicle's current battery voltage will be displayed.
Speed	The vehicle's current speed will be displayed.
Engine Hours	The vehicle's engine hours will be displayed.
Service Hours	The vehicle's service hours will be displayed.

## OPTIONS MENU

From the options menu you can view diagnostic codes, access the advanced menu, set the clock, and much more. For a full list of available options see below.

To enter the Options Menu, press and hold the MODE button.



OPTIONS MENU	NOTES
Diagnostic Codes	Only displays if fault codes are present or stored
Advanced Menu (if equipped)	Set maximum speed, and geofencing settings.
Units - Distance	Select MPH or KPH
Units - Temp	Select between °F and °C
Clock (if equipped)	Select between 12H or 24H, and set time
Backlight Color	Select between Blue or Red
Backlight Level	Set backlight brightness level
Service Hours	View/Set Service hours
Exit Menu	Exit

## FEATURES AND CONTROLS

### DIAGNOSTIC CODE

Diagnostic Code Screen will show available MIL that has come on during that ignition cycle.

To access the Diagnostic Code Screen, do the following:

1. Press and hold the MODE button to enter the Options Menu. "OPTIONS" will display on the screen for 3 seconds before showing first menu item.
2. Select "Diagnostic Codes" from the Options Menu by pressing the MODE button.

Toggle the Up/Down Buttons to cycle through Code(s).

#### NOTICE

This option will only be available if a fault code was set or is active during the current ignition key 'on' cycle. Turning off the ignition will clear any save fault codes from the gauge.

- ① Display area 1 will show FMI
- ② Display area 2 will show SPN
- ③ Clock Area will show Count.

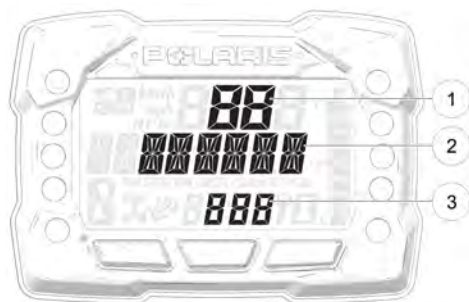

## NOTICE

When the gauge is displaying a fault code, the warning telltale (check engine or EPS) will blink to indicate which controller set the fault code.

3. To exit the Options Menu the user can select Exit Menu function from Options Menu, can hold Mode Button and exit out of Options Menu, or not press any button for 10 seconds, which will exit out of the Options Menu.

## **DIAGNOSTIC DISPLAY CODE DEFINITIONS**

**Open Load:** There is a break in the wires that lead to the item listed in the chart (injector, fuel pump, etc.), or the item has failed.

**Short-to-Ground:** The wire is shorted to ground between the electronic control unit and the item listed in the chart.

**Shorted Load:** The wires leading to the item listed in the chart are shorted together, or the item has shorted internally.

**Short-to-Battery:** The wire leading from the item listed in the chart to the electronic control unit is shorted to a wire at battery voltage.

<b>DIAGNOSTIC CODES</b>			
<b>COMPONENT</b>	<b>CONDITION</b>	<b>SPN</b>	<b>FMI</b>
Throttle Position Sensor	Voltage Too High	51	3
	Voltage Too Low	51	4
Engine Temperature Sensor	Voltage Too High	110	3
	Voltage Too Low	110	4
	Temperature Too High	110	16
	Engine Overheat Shutdown	110	0
Intake Air Temperature Sensor	Voltage Too High	105	3
	Voltage Too Low	105	4
Manifold Absolute Pressure Sensor	Voltage Too High	102	3
	Voltage Too Low	102	4
	Signal Out of Range	102	2
Crankshaft Position Sensor	Circuit Fault	636	8
	Plausibility Fault	636	2

## FEATURES AND CONTROLS

DIAGNOSTIC CODES			
COMPONENT	CONDITION	SPN	FMI
Vehicle Speed Signal	Speed Too High	84	8
	Plausibility Fault	84	2
Gear Sensor Signal	Voltage Too Low	523	4
	Voltage Too High	523	3
	Signal Fault	523	2
Injector 1 (MAG) (SDI Part Load)	Driver Circuit Open/Grounded	651	5
	Driver Circuit Short to B+	651	3
	Driver Circuit Grounded	651	4
Injector 2 (PTO) (SDI Part Load)	Driver Circuit Open/Grounded	652	5
	Driver Circuit Short to B+	652	3
	Driver Circuit Grounded	652	4
Ignition Coil Primary Driver 1 (MAG)	Driver Circuit Short to B+	1268	3
Ignition Coil Primary Driver 2 (PTO)	Driver Circuit Short to B+	1269	3
Fuel Pump Driver Circuit	Driver Circuit Open/Grounded	1347	5
	Driver Circuit Short to B+	1347	3
	Driver Circuit Grounded	1347	4
Fan Relay Driver Circuit	Driver Circuit Open/Grounded	1071	5
	Driver Circuit Short to B+	1071	3
	Driver Circuit Grounded	1071	4



## FEATURES AND CONTROLS

DIAGNOSTIC CODES			
COMPONENT	CONDITION	SPN	FMI
Idle Air Control	Driver Circuit Open/Grounded	634	5
	Driver Circuit Short to B+	634	3
	Driver Circuit Grounded	634	4
	Position Out of Range	634	7
Starter Enable Circuit	Driver Circuit Open/Grounded	1321	5
	Driver Circuit Short to B+	1321	3
	Driver Circuit Grounded	1321	4
Chassis Relay	Driver Circuit Open/Grounded	520208	5
	Driver Circuit Short to B+	520208	3
	Driver Circuit Grounded	520208	4
All Wheel Drive Control	Driver Circuit Open/Grounded	520207	5
	Driver Circuit Short to B+	520207	3
	Driver Circuit Grounded	520207	4
System Power	Voltage Too High	168	3
	Voltage Too Low	168	4
Throttle Safety Signal	Voltage Too High	520194	3
	Voltage Too Low	520194	4
	Signal Out of Range	520194	2
	Throttle Stuck	520194	7
Active Descent Control System	Driver Circuit Open/Grounded	520203	5

## FEATURES AND CONTROLS

DIAGNOSTIC CODES			
COMPONENT	CONDITION	SPN	FMI
	Driver Circuit Short to B+	520203	3
	Driver Circuit Grounded	520203	4
Idle Speed	Speed Too High	520211	3
	Speed Too Low	520211	4
Right Hand Control	Momentary Driveline Mode Switch Press	520468	31

DIAGNOSTIC CODES			
COMPONENT	CONDITION	SPN	FMI
<b>EPS MODELS ONLY</b>			
Vehicle Speed Sensor	Data Valid But Above Normal Operational Range - Most Severe Level	84	0
	Data Erratic, Intermittent Or Incorrect	84	2
	Abnormal Rate Of Change	84	10
	Received Network Data In Error	84	19
System Power	Data Valid But Above Normal Operational Range - Most Severe Level	168	0
	Voltage Above Normal, Or Shorted To High Source	168	3
	Voltage Below Normal, Or Shorted To Low Source	168	4
Engine Speed	Data Valid But Above Normal Operational Range - Most Severe Level	190	0

# FEATURES AND CONTROLS

DIAGNOSTIC CODES			
COMPONENT	CONDITION	SPN	FMI
<b>EPS MODELS ONLY</b>			
	Data Erratic, Intermittent Or Incorrect	190	2
	Received Network Data In Error	190	19
ECU Memory	Bad Intelligent Device Or Component	628	12
	Out Of Calibration	628	13
Calibration	Out Of Calibration	630	13
Steering Over Current Shut Down	Current Above Normal Or Grounded Circuit	520221	6
Steering Excessive Current Error	Current Above Normal Or Grounded Circuit	520222	6
Steering Torque Partial Failure	Condition Exists	520223	31
Steering Torque Full Failure	Condition Exists	520224	31
EPAS Inverter Temperature	Data Valid But Above Normal Operational Range - Most Severe Level	520225	0
	Data Valid But Above Normal Operating Range - Moderately Severe Level	520225	16
EPAS Communications Receive Data Error	Data Erratic, Intermittent Or Incorrect	520226	2
	Condition Exists	520226	31
Position Encoder Error	Root Cause Not Known	520228	11
	Bad Intelligent Device Or Component	520228	12
	Condition Exists	520228	31
EPAS Software Error	Bad Intelligent Device Or Component	520229	12

## FEATURES AND CONTROLS

DIAGNOSTIC CODES			
COMPONENT	CONDITION	SPN	FMI
EPS MODELS ONLY			
	Condition Exists	520229	31
EPAS Power Save Condition	Condition Exists	520231	31
EPS SEPIC Voltage Error	Voltage Above Normal, Or Shorted To High Source	524086	3
	Voltage Below Normal, Or Shorted To Low Source	524086	4

## UNIT SELECTION DISTANCE

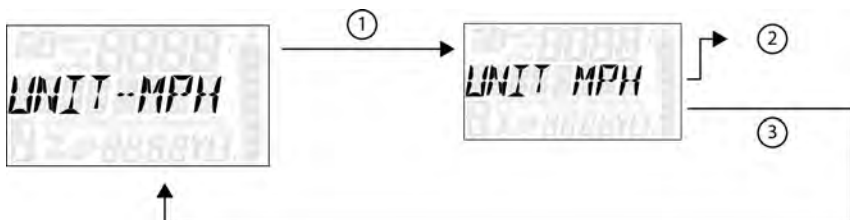

1. Press and hold the MODE button to enter the Options Menu.

### NOTICE

“OPTIONS” will display on the screen for 3 seconds before showing first menu item.

2. Select “Units-Distance” from the Options Menu by pressing the MODE button.

Reference the image shown above:

- ① Press the MODE button.
  - ② Toggle the Up/Down Buttons to change the units (MPH or KPH)
  - ③ With the correct unit displayed, Press the mode button which will set the unit and return to the Options Menu.
3. To exit the Options Menu the user can select Exit Menu function from Options Menu, can hold Mode Button and exit out of Options Menu, or not press any button for 10 seconds, which will exit out of the Options Menu.

## UNIT SELECTION TEMPERATURE

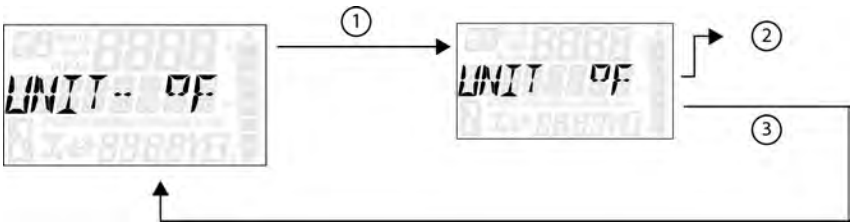

1. Press and hold the MODE button to enter the Options Menu.

### NOTICE

"OPTIONS" will display on the screen for 3 seconds before showing first menu item.

2. Select "Units - Temp" from the Options Menu by pressing the MODE button.

Reference the image shown above:

- ① Press the MODE button.
  - ② Toggle the Up/Down Buttons to change the units (°F or °C)
  - ③ With the correct unit displayed, Press the mode button which will set the unit and return to the Options Menu.
3. To exit the Options Menu the user can select Exit Menu function from Options Menu, can hold Mode Button and exit out of Options Menu, or not press any button for 10 seconds, which will exit out of the Options Menu.

## CLOCK

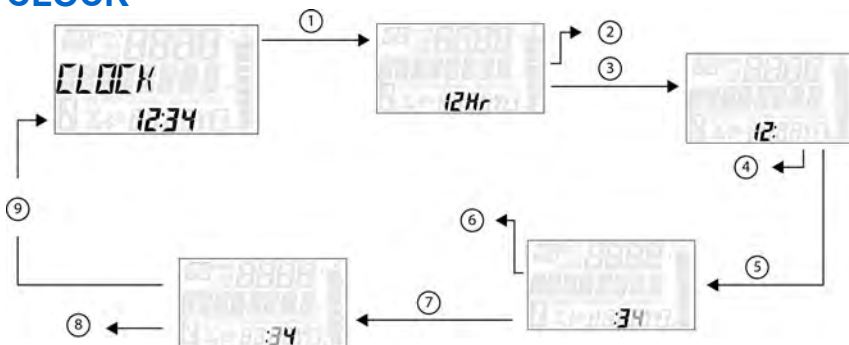

1. Press and hold the MODE button to enter the Options Menu.

### NOTICE

"OPTIONS" will display on the screen for 3 seconds before showing first menu item.

2. Select "Clock" from the Options Menu by pressing the MODE button.

Reference the image shown above:

- ① Press the MODE button.
  - ② Toggle the Up/Down Buttons to change the units (12H or 24H)
  - ③ With the correct unit displayed, Press the mode button which will set the unit.
  - ④ Toggle the Up/Down Buttons to change the units (Cycles Hours)
  - ⑤ With the correct unit displayed, Press the mode button which will set the unit.
  - ⑥ Toggle the Up/Down Buttons to change the units (Cycles 10s of Minutes)
  - ⑦ With the correct unit displayed, Press the mode button which will set the unit.
  - ⑧ Toggle the Up/Down Buttons to change the units (Cycles 1s of Minutes)
  - ⑨ With the correct unit displayed. Press the mode button which will set the unit and return to the Options menu.
3. To exit the Options Menu the user can select Exit Menu function from Options Menu, can hold Mode Button and exit out of Options Menu, or not press any button for 10 seconds, which will exit out of the Options Menu.

## BACK LIGHT COLOR

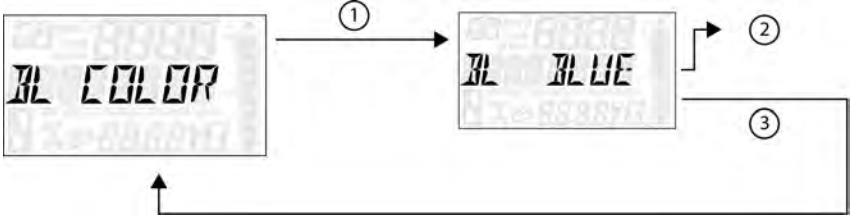

1. Press and hold the MODE button to enter the Options Menu.

### NOTICE

“OPTIONS” will display on the screen for 3 seconds before showing first menu item.

2. Select “Backlight Color” from the Options Menu by pressing the MODE button.

Reference the image shown above:

- ① Press the MODE button.
  - ② Toggle the Up/Down Buttons to change the units (Blue or Red)
  - ③ With the correct unit displayed, Press the mode button which will set the unit and return to the Options Menu.
3. To exit the Options Menu the user can select Exit Menu function from Options Menu, can hold Mode Button and exit out of Options Menu, or not press any button for 10 seconds, which will exit out of the Options Menu.

### BACK LIGHT LEVEL

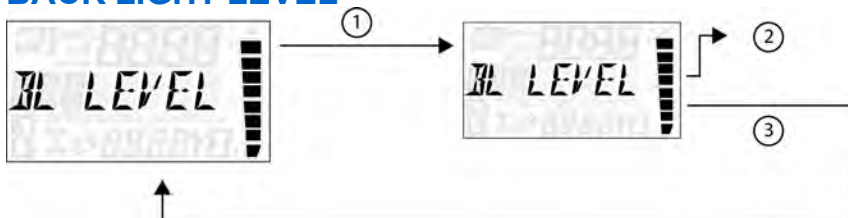

1. Press and hold the MODE button to enter the Options Menu.

#### NOTICE

"OPTIONS" will display on the screen for 3 seconds before showing first menu item.

2. Select "Backlight Level" from the Options Menu by pressing the MODE button.

Reference the image shown above:

- ① Press the MODE button.
  - ② Toggle the Up/Down Buttons to change the units (Increase or Decrease Level)
  - ③ With the correct unit displayed, Press the mode button which will set the unit and return to the Options Menu.
3. To exit the Options Menu the user can select Exit Menu function from Options Menu, can hold Mode Button and exit out of Options Menu, or not press any button for 10 seconds, which will exit out of the Options Menu.



## SERVICE HOURS

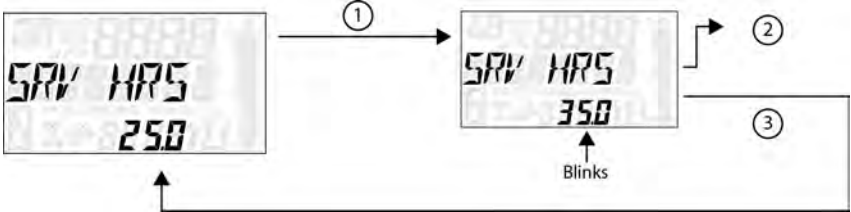

1. Press and hold the MODE button to enter the Options Menu.

### NOTICE

"OPTIONS" will display on the screen for 3 seconds before showing first menu item.

2. Select "Service Hours" from the Options Menu by pressing the MODE button.

Reference the image shown above:

- ① Press the MODE button.
- ② Toggle the Up/Down Buttons to change the units (0, 5, 10 - 95, 100)
- ③ With the correct unit displayed, press the MODE button, which will set the unit and return you to the Options Menu.

### NOTICE

To reset service hours after they have counted down to "0.0", reselect the existing setpoint or select a new service hour value.

3. To exit the Options Menu the user can select Exit Menu function from Options Menu, can hold Mode Button and exit out of Options Menu, or not press any button for 10 seconds, which will exit out of the Options Menu.

## PIN ACTIVATED SECURITY SYSTEM (P.A.S.S.) (IF EQUIPPED) — INSTRUMENT CLUSTER

The optional PIN Activated Security System (P.A.S.S.) is to prevent unauthorized use. When enabled, the vehicle cannot be operated until a valid passcode has been entered using the Instrument Cluster.

To enable/disable P.A.S.S. using the Instrument Cluster, follow the procedures below.

## FEATURES AND CONTROLS

---

### **ENABLE P.A.S.S.**

#### NOTICE

After activating P.A.S.S. for the first time you must power down the vehicle and allow the electronic control module (ECM) to fully shutdown before restarting. This may take up to three minutes.

Once a new passcode has been enabled, it cannot be changed unless you first disable the system. Then you can re-follow the steps outlined in the ENABLE P.A.S.S. section to enter a new passcode.

1. Press and hold the MODE button to enter the "OPTIONS" menu.
2. Use the UP/DOWN toggle buttons to cycle through options until "REQUIRE PIN TO START" appears. Press the MODE button to select.
3. If required, "ENTER NEW PIN" will appear. Use the UP/DOWN toggle buttons to cycle to your desired first digit. Press the MODE button to select the digit.
4. Continue until all four digits of your desired passcode have been selected. Once finished, "NEW PIN SET" will flash momentarily and then revert back to the "REQUIRE PIN TO START" screen.  
Please record your passcode.
5. To enable your new passcode, use the UP/DOWN toggle buttons to change the flashing "OFF" at bottom of screen to "ON". **If this step is skipped, P.A.S.S. will not be enabled.**
6. Press the MODE button to re-enter the "OPTIONS" menu. The vehicle will now require passcode entry before next startup.

You can exit the "OPTIONS" menu three different ways.

- Toggle to "EXIT" and press the MODE button.
- Hold the MODE button for a few seconds.
- Do nothing, allowing the system to automatically revert back to the main screen.

#### NOTICE

If the battery becomes low while the P.A.S.S. system is enabled, the gauge may show "New Vehicle Detected" after the battery has been recharged/replaced. Leave the key in the ON position to allow system reconfirmation.

### ***DISABLE P.A.S.S.***

1. Press and hold the MODE button to enter the "OPTIONS" menu.
2. Use the UP/DOWN toggle buttons to cycle through options until "REQUIRE PIN TO START" appears. Press the MODE button to select.
3. Enter current passcode.
4. Use the UP/DOWN toggle buttons to change the flashing "ON" at bottom of screen to "OFF".
5. Press the MODE button to re-enter the "OPTIONS" menu. P.A.S.S. is now disabled.

You can exit the "OPTIONS" menu three different ways.

- Toggle to "EXIT" and press the MODE button.
- Hold the MODE button for a few seconds.
- Do nothing, allowing the system to automatically revert back to the main screen.



---

## OPERATION

### IMPORTANT INFORMATION

 **WARNING**

Failure to operate the vehicle properly can result in a collision, loss of control, accident or rollover, which may result in serious injury or death. Read and understand all safety warnings outlined in the safety section of this owner's manual.

### VEHICLE BREAK-IN PERIOD

The break-in period for your new *RANGER* is the first 25 hours of operation, or the time it takes to use the first two tanks full of fuel. No single action on your part is as important as a proper break-in period. Careful treatment of a new engine will result in more efficient performance and longer life for the engine. Perform the following procedures carefully.

**NOTICE**

Excessive heat build-up during the first 3 hours of operation will damage close-fitted engine parts and drive components. Do not operate at full throttle or high speeds during the first 3 hours of use.

### FUEL RECOMMENDATIONS

Most Polaris Off-Road Vehicles require unleaded gasoline with a minimum pump octane number of 87. Do not use fuel with an ethanol content greater than 10 percent. Octane in excess of 87 will not damage the engine but typically will not result in performance gains.

Be aware that fuel is mixed differently depending on the season. Summer fuel has a low Reid Vapor Pressure (RVP), which makes it less likely to evaporate in warm weather riding. This prevents vapor lock issues. Winter fuel has a higher RVP, which increases evaporation to ease starting in cold weather conditions. In winter, it's important to drain your tank and fill it with fresh fuel from a high volume gas station. This ensures your fuel is a winter blend. After filling the tank, run the engine for 10 to 15 minutes. This will fill the fuel system with the fresh winter-blended fuel.

## OPERATION

---

### ENGINE AND DRIVETRAIN BREAK-IN

1. Fill the fuel tank with clean, fresh fuel.
2. Check the oil level. Add the recommended oil as needed to maintain the oil level in the normal (safe) operating range.
3. Drive slowly at first. Select an open area that allows room to familiarize yourself with vehicle operation and handling.
4. Vary throttle positions. Do not operate at sustained idle.
5. Perform regular checks on fluid levels, controls and areas outlined on the daily pre-ride inspection checklist.
6. During the break-in period, change both the oil and the filter at 25 hours.
7. Check fluid levels of transmission and all gearcases after the first 25 hours of operation and every 100 hours thereafter.
8. Pull only light loads.

### PVT BREAK-IN (CLUTCHES/BELT)

Always break in the clutches and drive belt of new vehicles, as well as after a belt replacement.

A proper break-in of the clutches and drive belt will ensure a longer life and better performance. Break in the clutches and belt by operating at slower speeds during the break-in period as recommended. Pull only light loads. Avoid aggressive acceleration and high speed operation during the break-in period.

If a belt fails, always clean any debris from the PVT intake and outlet duct and from the clutch and engine compartments when replacing the belt.

### PRE-RIDE INSPECTION

Failure to inspect and verify that the vehicle is in safe operating condition before operating increases the risk of an accident. Always inspect the vehicle before each use to make sure it's in safe operating condition.

ITEM	REMARKS	REF.
Brake system/pedal travel	Ensure proper operation	page 40 page 118
Brake fluid	Ensure proper level	page 118
Front suspension	Inspect	page 120
Rear suspension	Inspect	page 120
Steering	Ensure free operation	page 119

ITEM	REMARKS	REF.
Tires	Inspect condition and pressure	page 120
Wheels/fasteners	Inspect, ensure fastener tightness	page 120
Frame nuts, bolts, fasteners	Inspect, ensure tightness	–
Fuel and oil	Ensure proper levels	page 46 page 87
Coolant level	Ensure proper level	page 102
Coolant hoses	Inspect for leaks	–
Throttle	Ensure proper operation	–
Indicator lights/switches	Ensure proper operation	page 38
Intake pre-filters	Inspect, clean	page 115
Headlamps	Check operation, apply POLARIS dielectric grease when lamp is replaced	page 124
Brake light/tail lamps	Check operation	–
Seat Latch	Push down on the seat back to ensure the latch is secure	<b>Seat Belt Inspection-</b> page 42
Seat Belt	Check length of belt for damage, check latches for proper operation	<b>Seat Belt Inspection-</b> page 42
Cab Doors (If equipped)	Check doors and latches for wear or damage.	page 44
Riding Gear	Wear approved helmet, goggles, and protective clothing	page

## STARTING THE ENGINE

1. Position the vehicle on a level surface outdoors or in a well ventilated area.
2. Sit in the driver's seat and fasten the seat belt. Secure the cab nets.
3. Place the transmission in PARK and apply the PARKING BRAKE (if equipped).
4. Apply the brakes. Do not press the throttle pedal while starting the engine.
5. Turn the ignition key past the ON/RUN position to START. Engage the starter for a maximum of five seconds. Release the key when the engine starts.

## OPERATION

---

6. If the engine does not start within five seconds, return the ignition switch to the OFF position and wait five seconds. Repeat steps 5 and 6 until the engine starts.
7. Vary the engine RPM slightly with the throttle to aid in warm up until the engine idles smoothly.

### NOTICE

Operating the vehicle immediately after starting could cause engine damage. Allow the engine to warm up for several minutes before operating the vehicle.

## STOPPING THE ENGINE

1. Release the throttle pedal completely and brake to a complete stop.
2. Place the transmission in PARK.
3. Engage the PARKING BRAKE (if equipped).
4. Slowly release the brake pedal and make sure the transmission is in PARK before exiting the vehicle.
5. Turn the engine off.

### WARNING

A rolling vehicle can cause serious injury. Always place the transmission in PARK and engage the PARKING BRAKE (if equipped) when stopping the engine.



---

## BRAKING

1. Release the throttle pedal completely.

**TIP**

When the throttle pedal is released completely and the engine speed drops near an idle, the vehicle has no engine braking.

2. Press on the brake pedal evenly and firmly.

**TIP**

If the throttle pedal and brake pedal are applied simultaneously, engine power may be limited.

3. Practice starting and stopping (using the brakes) until you're familiar with the controls.

### HAULING CARGO

 **WARNING**

Hauling cargo improperly can alter vehicle handling and may cause loss of control or brake instability, which can result in serious injury or death. Always follow these precautions when hauling cargo:

Never exceed the maximum weight capacity of the vehicle. When determining the weight you are adding to the vehicle, include the weight of the operator, passengers, non-factory installed accessories, loads in the rack or box and the load on the trailer tongue. The combined weight of these items must not exceed the maximum weight capacity.

**REDUCE SPEED AND ALLOW GREATER DISTANCES FOR BRAKING WHEN HAULING CARGO.**

Always load the cargo box with the load as far forward and as low as possible. When operating over rough or hilly terrain, reduce speed and cargo to maintain stable driving conditions.

Always operate the vehicle with extreme care when hauling or towing loads. Slow down and drive in the lowest gear available. Always use LOW gear when towing or hauling heavy loads.

**SECURE ALL LOADS BEFORE OPERATING.** Unsecured loads can create unstable operating conditions, which could result in loss of control of the vehicle.

**OPERATE ONLY WITH STABLE AND SAFELY ARRANGED LOADS.** When handling off-centered loads that cannot be centered, securely fasten the load and operate with extra caution. Always attach the tow load to the hitch point designated for your vehicle.

**HEAVY LOADS CAN CAUSE BRAKING AND CONTROL PROBLEMS.** Use extreme caution when applying brakes with a loaded vehicle. Avoid terrain or situations that may require backing downhill.

**USE EXTREME CAUTION** when operating with loads that extend over the rack sides. Stability and maneuverability may be adversely affected, causing a rollover.

**DO NOT TRAVEL FASTER THAN THE RECOMMENDED SPEEDS.** Vehicle should never exceed 16 km/h (10 MPH) while towing a load on a level grass surface. Vehicle speed should never exceed 8 km/h (5 MPH) when towing loads in rough terrain, while cornering, or while ascending or descending a hill.

## LOAD CAPACITY

Your vehicle has been designed to carry or tow specific capacities. Always read and understand the load distribution warnings listed on the warning labels. The total load (operator, passengers, non-factory installed accessories, cargo and weight on hitch) must not exceed the maximum weight capacity of the vehicle. Never exceed the following capacities:

MODEL	MAXIMUM CAPACITIES (LEVEL GROUND)	CARGO BOX
<i>RANGER 570</i>	454 kg (1000 lbs.)	226 kg (500 lbs.)
<i>RANGER CREW 570</i>	547 kg (1225 lbs)	226 kg (500 lbs.)

### WARNING

Driving with passengers in the cargo box can result in severe injury or death. Never allow passengers to ride in the cargo box. Passengers must always ride in the cab with seat belts fastened securely.

## TOWING A RANGER

Towing this vehicle is not recommended. Always transport the vehicle on a trailer or flatbed with all four wheels off the ground.

If towing a disabled vehicle is unavoidable, place the disabled vehicle's transmission in neutral. Tow the shortest distance possible. Do not operate faster than 16 km/h (10 MPH).

## TOWING LOADS

### WARNING

Towing improperly can alter vehicle handling and may cause loss of control or brake instability.

Always follow these precautions when towing:

1. Never load more than 68.1 kg (150 lbs.) tongue weight on the towing bracket.
2. Always shift to low gear for towing.
3. When towing a disabled *RANGER* vehicle, place the disabled vehicle's transmission in neutral. Do not operate the vehicle faster than 16 km/h (10 MPH) when towing.

## OPERATION

---

4. Towing a trailer increases braking distance. Do not operate the vehicle faster than 16 km/h (10 MPH) when towing. Towing a trailer increases braking distance.
5. Do not tow more than the recommended weight for the vehicle. See the towing capacity chart below and the specifications in the Specifications chapter.
6. Attach a trailer to the trailer hitch bracket only. Do not attach a trailer to any other location or you may lose control of the vehicle.
7. Never tow a trailer on a grade steeper than 15°.
8. Always be mindful of the trailer's reaction to vehicle movements when driving off-road.

MODEL	TOTAL TOWED LOAD WEIGHT (LEVEL GROUND)	TOTAL TOWED LOAD WEIGHT (15° GRADE)	TOTAL HITCH VERTICAL WEIGHT	MAXIMUM TOWING SPEED
RANGER 570	680.4 kg (1500 lbs.)	386 kg (850 lbs.)	68.1 kg (150 lbs.)	16 km/h (10 MPH)

## BELT LIFE

To extend belt life, use low gear when hauling or towing heavy cargo. Using high gear for heavy loads, hilly terrain or in wet, muddy conditions will increase the chance of drive belt burning.

## DUMPING THE CARGO BOX

To dump the cargo box, do the following:

1. Select a level site to dump the cargo box. Do not attempt to dump or unload the vehicle while parked on an incline.
2. Apply the brakes. Place the transmission in PARK.
3. Engage the PARKING BRAKE (if equipped).
4. Ensure that the cargo is positioned evenly or toward the front of the cargo box.

5. Release the tailgate by pulling up on the tailgate latch.

**⚠ WARNING**

If the weight distribution on the box is located toward the rear of the box when the release lever is pulled forward, the box may dump unexpectedly and cause serious injury to the operator or bystanders. Never operate the Release Lever dump lever without ensuring that the load is positioned evenly or at the front of the box.

6. Stand clear and pull up on the cargo box release lever ①. Lift the front of the cargo box to dump the cargo.

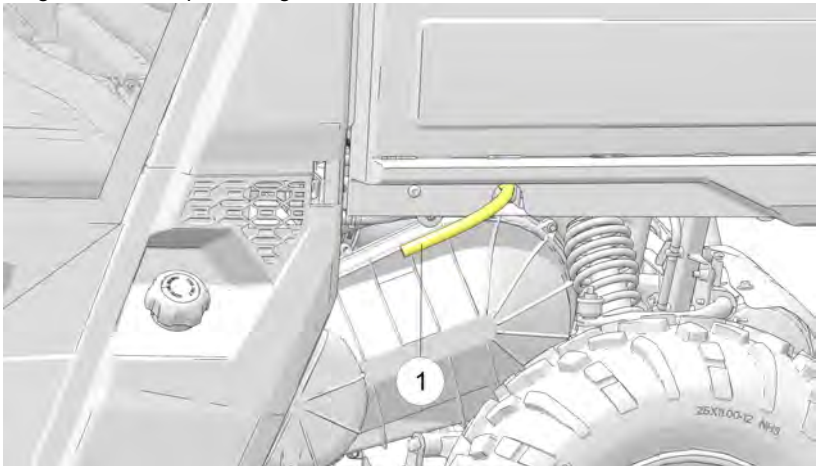

7. Lower the cargo box and push down securely to latch.

**⚠ WARNING**

Operating the vehicle while the cargo box is raised could result in severe injury. The box could close unexpectedly and cause injury to the driver or passenger. The rear tires could also catch the rear of a raised box, damaging the vehicle and creating hazardous driving conditions. Never operate this vehicle with the cargo box in the raised position.

## OPERATION

---

# ALL WHEEL DRIVE/REAR DIFFERENTIAL SYSTEM

If your model is equipped with a lockable differential, you can choose to operate with an open differential or a closed differential.

## ENGAGING AWD

### NOTICE

Switching to AWD while the rear wheels are spinning may cause severe drive shaft and clutch damage. Always switch to AWD while the rear wheels have traction or are at rest.

- ① All-Wheel Drive (AWD)
- ② Differential Lock (2WD)
- ③ Differential Unlock (TURF Mode)

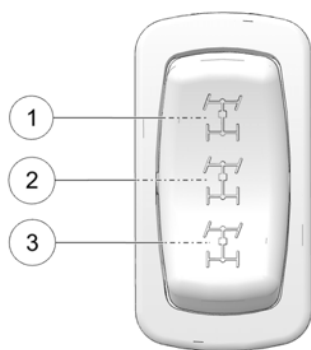

Press the top of the driveline mode switch to engage All Wheel Drive (AWD). The 4X4 indicator illuminates in the rider information center to indicate that the vehicle is in AWD. When the AWD switch is on, the front gearcase will automatically engage any time the rear wheels lose traction. When the rear wheels regain traction, the front gearcase will automatically disengage. There is no limit to the length of time the vehicle may remain in AWD. Initially, the vehicle's electronic system will not enable the AWD until the engine RPM is below 3100. Once enabled, the AWD remains enabled until the switch is turned off. If the switch is turned off while the front gearcase is moving, it will not disengage until the rear wheels regain traction.

Engage the AWD before getting into conditions where front wheel drive may be needed. If the rear wheels are spinning, release the throttle before switching to AWD.

## DISENGAGING AWD

Move the driveline mode switch to the center or bottom position to disengage AWD. If the switch is turned off while the front hubs are driving, they will not release until the rear wheels regain traction.

In some situations, the front gearcase may remain locked after turning the AWD switch off. If this occurs, you may notice increased steering effort and some vehicle speed restriction. Perform the following procedure to unlock the front gearcase.

To disengage AWD, do the following:

1. Stop the vehicle.
2. Operate in reverse for at least 3 m.
3. Stop completely.
4. Shift into low gear and drive forward.
5. If the front gearcase remains locked after following these instructions, see your dealer or other qualified service person for service.

## LOCKING THE DIFFERENTIAL

Move the switch to the center position to lock the differential and operate in two wheel drive (2WD). Locking the differential in slippery or low traction conditions helps improve traction. When the rear differential is locked, both rear wheels rotate at the same speed.

## UNLOCKING THE DIFFERENTIAL (TURF MODE)

When operating in TURF mode, the inside rear wheel will rotate independently from the outside wheel during turns. Operate in TURF mode only as needed to protect smooth, level surfaces from tire damage. DO NOT operate in TURF mode when climbing or descending hills, when sidehilling, or when operating on uneven, loose, or slippery terrain such as sand, gravel, ice, snow, obstacles, and water crossings. Always operate in AWD on these types of terrain.

### WARNING

Operating in TURF mode (if equipped) when on sloped, uneven, or loose terrain could cause loss of control and result in serious injury or death. One rear wheel may slip and lose traction or may lift up and grab when it touches the ground again.

Press the bottom of the switch to unlock the differential and allow the rear drive wheels to operate independently (1WD). When the rear differential is unlocked, the rear wheels can rotate at different speeds. Unlock the differential to make maneuvering easier and minimize damage to turf.

## OPERATION

### NOTICE

Damage to the differential can occur if it is engaged while the vehicle is traveling at high speeds or while the rear wheels are spinning. Slow the vehicle to nearly stopped before engaging the differential.

### WARNING

Never operate in TURF mode (if equipped) while operating on a hill or other irregular terrain. Always move the switch to AWD before ascending or descending a hill.



# EMISSION CONTROL SYSTEMS

## NOISE EMISSION CONTROL SYSTEM

Do not modify the engine, intake or exhaust components, as doing so may affect compliance with governmental noise level requirements.

## SPARK ARRESTER

Your POLARIS vehicle has a spark arrester that was designed for on-road and off-road operation. It is required that this spark arrester remain installed and functional when the vehicle is operated.

## EXHAUST EMISSION CONTROL SYSTEM

Exhaust emissions are controlled by engine design. An electronic fuel injection (EFI) system controls fuel delivery. The engine and EFI components are set at the factory for optimal performance and are not adjustable.

The emissions label is located on the inside of the lower left frame tube (below driver's foot area).

## ELECTROMAGNETIC INTERFERENCE

This vehicle complies with the EMC requirements of UN ECE Regulation 10.

Non-ionizing Radiation: This vehicle emits some electromagnetic energy. People with active or non-active implantable medical devices (such as heart monitoring or controlling devices) should review the limitations of their device and the applicable electromagnetic standards and directives that apply to this vehicle.



## MAINTENANCE

### OVERVIEW

Any qualified repair shop or person may maintain, replace or repair the emission control devices or systems on your vehicle. An authorized POLARIS dealer can perform any service that may be necessary for your vehicle. POLARIS also recommends POLARIS parts for emissions-related service, however equivalent parts can be used.

It is a potential violation of the EU law if a part supplied by an aftermarket parts manufacturer reduces the effectiveness of the vehicle's emission controls. Tampering with emission controls is prohibited by law.

Owners are responsible for performing the scheduled maintenance identified in this owner's manual. Careful periodic maintenance will help keep your vehicle in safe, reliable condition. Inspect, clean, lubricate, adjust and replace parts as necessary. When inspection reveals the need for replacement parts, genuine POLARIS parts are available from your POLARIS dealer. Equivalent parts may be used for emissions-related service.

Record maintenance and service in the Maintenance Log beginning on page 165. Service and adjustments are important for proper vehicle operation. If you're not familiar with safe service and adjustment procedures, a qualified dealer can perform these operations. Maintenance intervals in the following chart are based upon average riding conditions and an average vehicle speed of approximately 10 miles per hour. Vehicles subjected to severe use must be inspected and serviced more frequently.

### POLARIS MAINTENANCE SCHEDULE

The intervals shown are based on vehicles operated under normal conditions.

Each interval is given in hours and miles (kilometers). Items should be serviced at whichever interval comes first.

Continue to reference the following maintenance schedules at the given intervals as hours and miles (kilometers) increase on the vehicle.

## MAINTENANCE

---

*Vehicles subjected to severe use must be serviced at 50% of the stated interval. Examples of Severe Use: Frequent immersion in mud, water, or sand, constant high RPM use, prolonged low-speed heavy load operation, extended idle, and short trip cold weather operation.*

### **INITIAL BREAK-IN SERVICE FIRST 25 HOURS**

Battery	Check terminals; terminals should be tight and free of corrosion. Clean, test, and replace as necessary.
Engine Oil and Filter	Change the engine oil and filter.
Front / Rear Gearcase Fluid	Change fluid.
Transmission Fluid	Initial fluid level inspection; inspect for fluid leaks; add lubricant if needed.
The break-in period consists of the first 25 hours of operation. Careful treatment of a new engine and drive components will result in more efficient performance and longer life for these components. The items outlined in this service interval only need to be performed at the first 25 hours of operation. They do not need to be performed every 25 hours.	

*Vehicles subjected to severe use must be serviced at 50% of the stated interval. Examples of Severe Use: Frequent immersion in mud, water, or sand, constant high RPM use, prolonged low-speed heavy load operation, extended idle, and short trip cold weather operation.*

### **EVERY 50 HOURS / 500 MILES (800 KM)**

Battery	Check terminals; terminals should be tight and free of corrosion. Clean, test, and replace as necessary.
---------	--

*Vehicles subjected to severe use must be serviced at 50% of the stated interval. Examples of Severe Use: Frequent immersion in mud, water, or sand, constant high RPM use, prolonged low-speed heavy load operation, extended idle, and short trip cold weather operation.*

### EVERY 100 HOURS / 1000 MILES (1600 KM) OR YEARLY

Air Filter	Replace air filter. Ensure proper installation of filter and airbox cover. Inspect ducts and screens; clean as necessary.
Battery	Check terminals; terminals should be tight and free of corrosion. Clean, test, and replace as necessary.
Drive Belt	Inspect; clean; replace as needed.
* Have an authorized Polaris dealer or other qualified person perform these services.	

## MAINTENANCE

---

*Vehicles subjected to severe use must be serviced at 50% of the stated interval. Examples of Severe Use: Frequent immersion in mud, water, or sand, constant high RPM use, prolonged low-speed heavy load operation, extended idle, and short trip cold weather operation.*

### **EVERY 200 HOURS / 2000 MILES (3200 KM) OR YEARLY**

Air Filter	Replace air filter. Ensure proper installation of filter and airbox cover. Inspect ducts and screens; clean as necessary.
Battery	Check terminals; terminals should be tight and free of corrosion. Clean, test, and replace as necessary.
Brake System	Inspect fluid level; inspect for fluid leaks; add recommended brake fluid from a sealed container if needed. Inspect brake pad wear.
Cooling System	Inspect fluid level; inspect for fluid leaks; add coolant if needed. Inspect coolant strength seasonally; pressure test system yearly.
Drive Belt	Inspect; clean; replace as needed.
Engine Oil and Filter	Change the engine oil and filter.
Fuel System*	Cycle key to pressurize fuel pump; check for leaks at fuel system connections, check for leaks at fill cap. Check for signs of wear on fuel lines.
Front Gearcase Fluid	Change fluid.
General Lubrication	Locate all applicable fittings and grease.
Radiator	Clean radiator of debris, straighten any damaged fins. Inspect for damage to radiator.
Shift Cable / Linkage	Inspect cable; adjust linkage as required if shifting is poor.
Shocks	Inspect seals and bushings; replace as needed.
Spark Plug	Replace as needed.
Steering Components	Inspect tie rods, steering rack, steering boots, and other steering components for tightness and damage.

## EVERY 200 HOURS / 2000 MILES (3200 KM) OR YEARLY

Suspension Components*	Inspect tie rods, wheel bearings, suspension bushings, and ball joints for loose or worn components; replace as needed. Inspect shock absorbers for leaks or damage.
Throttle Body / Air Intake Ducts / Flanges	Inspect duct for proper sealing / air leaks.
Tires	Inspect for tire damage / dry-rot in tires. Verify there is adequate tread depth.
Transmission Fluid	Change fluid.
Valve Clearance*	Inspect; adjust as needed.
Wiring	Inspect for wear, routing, and retention.
* Have an authorized Polaris dealer or other qualified person perform these services.	

*Vehicles subjected to severe use must be serviced at 50% of the stated interval. Examples of Severe Use: Frequent immersion in mud, water, or sand, constant high RPM use, prolonged low-speed heavy load operation, extended idle, and short trip cold weather operation.*

## ADDITIONAL MAINTENANCE INTERVALS

<b>Every 400 hours / 4000 miles (6400 km)</b>	Clutches*	Inspect bushings, rollers, wearable parts; clean; replace worn parts.
	Spark Arrestor	Clean out. Inspect after every ride where submerged in mud.
<b>Every 24 months / 2 years</b>	Brake Fluid	Change fluid.
<b>Every 60 months / 5 years</b>	Coolant	Change fluid.
* Have an authorized Polaris dealer or other qualified person perform these services.		

## MAINTENANCE

---

### LUBRICATION RECOMMENDATIONS

Check and lubricate all components at the intervals outlined in the POLARIS Maintenance Schedule beginning on page , or more often under severe use, such as wet or dusty conditions. Items not listed in the chart should be lubricated at the general lubrication interval.

ITEM	LUBE	METHOD
Engine Oil	PS-4 5W-50 4-Cycle Oil	Add to proper level on dipstick. See page 87.
Brake Fluid	DOT 4 Brake Fluid	Maintain level between fill lines. See page 118.
Transmission Oil (Main Gearcase)	AGL Gearcase Lubricant & Transmission Fluid	See page 93.
Front Gearcase Oil	Demand Drive Fluid	See page 95.
Front Prop Shaft Yoke	U-Joint Grease	Locate fittings and grease.



## ENGINE OIL

Always check and change the oil at the intervals outlined in the POLARIS Maintenance Schedule section. Always use the recommended engine oil.

### NOTICE

Allowing dirt or debris to enter the engine can result in serious engine damage. Always clean away all dirt and debris from the dipstick area before removing the dipstick.

## OIL CHECK

The oil dipstick ① is located on the engine. Access the dipstick through the right rear wheel well.

### NOTICE

Oil level should be checked when the engine is cold.

1. Position the vehicle on a level surface.
2. Place the transmission in PARK.
3. Always clean away all dirt and debris from the dipstick area before removing the dipstick. Remove the dipstick. Wipe it dry with a clean cloth.
4. Reinstall and tighten the dipstick.
5. Remove the dipstick and check the oil level.

## MAINTENANCE

---

6. Add the recommended fluid as needed. Maintain the oil level in the safe range between the FULL ② and ADD ③ marks. Do not overfill.

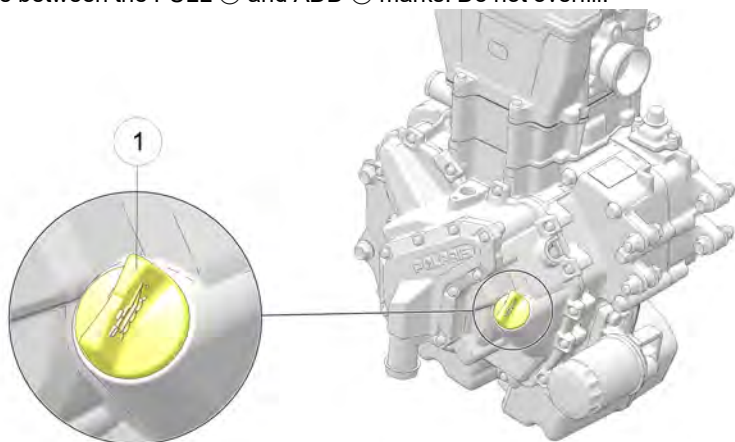

7. Reinstall and tighten the dipstick.

## OIL AND FILTER CHANGE

Always check and change the oil at the intervals outlined in the Polaris Maintenance Schedule section. Always change the oil filter whenever changing oil.

The engine drain plug ① is located on the bottom of the crankcase. Use a 6mm hex bit socket or equivalent.

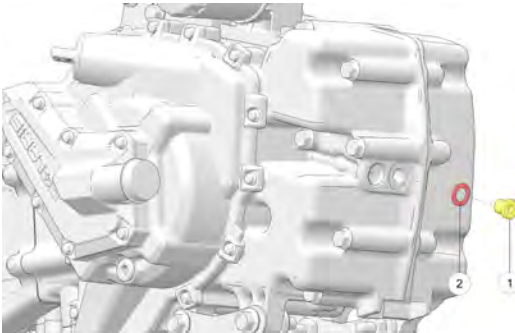

1. Position the vehicle on a level surface. Place the transmission in PARK. Apply the brakes.
2. Start the engine. Allow it to idle for two to three minutes. Stop the engine.
3. Clean the area around the drain plug.

**⚠ CAUTION**

Hot oil can cause burns to skin. Do not allow hot oil to contact skin.

## MAINTENANCE

---

4. Place a drain pan beneath engine crankcase and remove the drain plug ①.

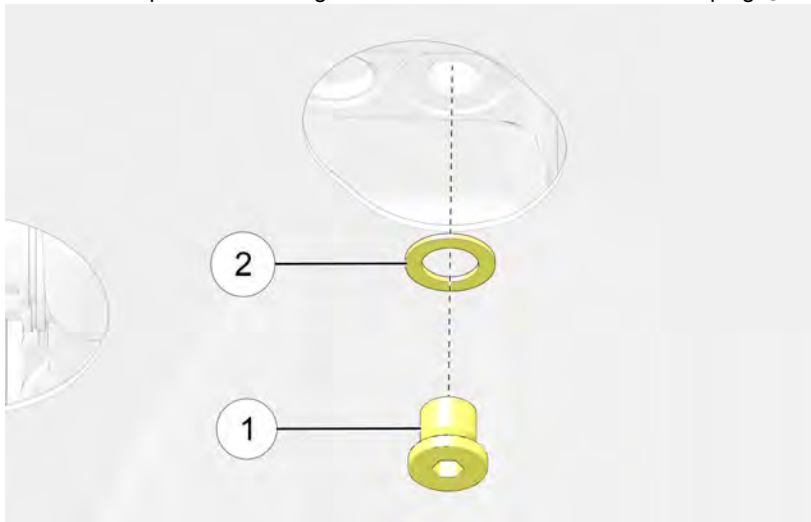

5. Allow the oil to drain completely.
6. Install a new sealing washer ② on the drain plug.

### TIP

The sealing surfaces on drain plug and crankcase should be clean and free of burrs, nicks or scratches.

7. Reinstall the drain plug.

### TORQUE

12 ft-lbs (16 Nm)

- Using a cap-style oil filter wrench or equivalent, turn the filter ③ counter-clockwise to remove it.

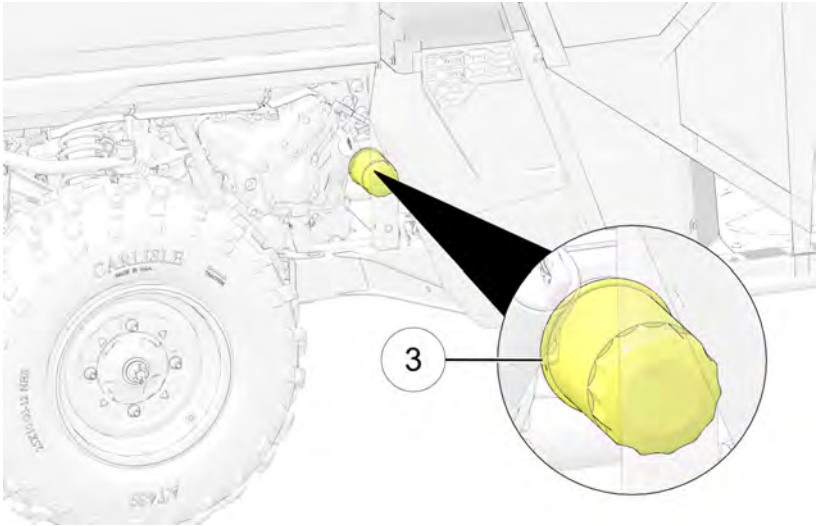

- Using a clean dry cloth, clean the filter sealing surface on the crankcase. Make sure the old filter o-ring is completely removed.
- Lubricate the o-ring on the new filter with a film of fresh engine oil. Check to make sure the o-ring is in good condition.
- Install the new filter and turn by hand until the filter gasket contacts the sealing surface, then turn an additional 3/4 turn.
- Always clean away all dirt and debris from the dipstick area before removing the dipstick. Remove the oil cap ④ or the dipstick ⑤ and fill the sump with 1.9 liters (2 qts.) of recommended oil.



- Reinstall and tighten the dipstick.

## MAINTENANCE

---

14. Make sure the transmission is in PARK. Apply the brakes.
15. Start the engine. Allow it to idle for one to two minutes.
16. Stop the engine. Inspect for leaks.
17. Re-check the oil level on the dipstick and add oil as necessary to bring the level to the upper mark on the dipstick.
18. Dispose of used filter and oil properly.

## GEARCASES

### GEARCASE SPECIFICATION CHART

GEARCASE	LUBRICANT	CAPACITY	FILL PLUG TORQUE	DRAIN PLUG/ LEVEL CHECK PLUG TORQUE
Main Gearcase (Transmission)	AGL Gearcase Lubricant & Transmission Fluid	1200 ml (40.6 oz.)	12 ft-lbs (16 N·m)	12 ft-lbs (16 N·m)
Front Gearcase	Demand Drive Fluid	200 ml (6.8 oz.)	12 ft-lbs (16 N·m)	12 ft-lbs (16 N·m)

## TRANSMISSION (MAIN GEARCASE)

Always check and change the transmission oil at the intervals outlined in the POLARIS Maintenance Schedule beginning on page . Maintain the oil level even with the bottom thread of the fill plug hole.

Refer to the Gearcase Specifications Chart for recommended lubricants, capacities and torque specifications. See page 147 for the part numbers of POLARIS products.

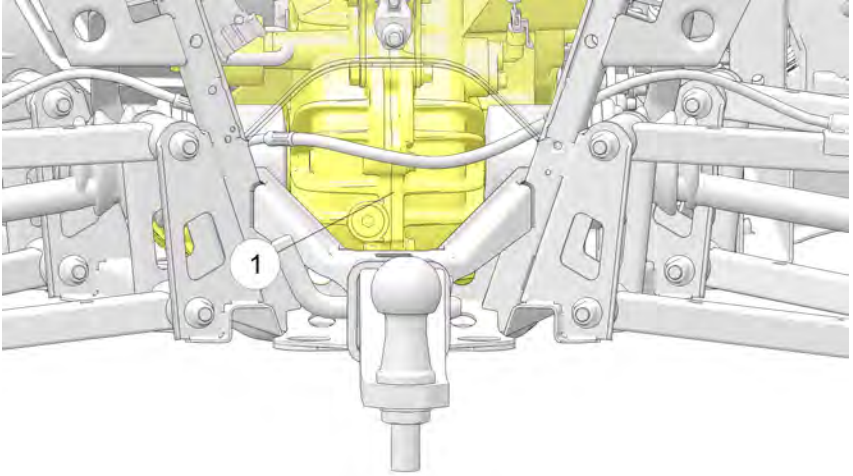

## MAINTENANCE

---

### **FLUID CHECK**

The fill plug is located on the rear of the gearcase. Maintain the fluid level at the bottom of the fill plug hole.

1. Position the vehicle on a level surface.
2. Remove the fill plug ①.
3. Check the fluid level.
4. Add the recommended fluid to the bottom of the fill plug hole. Do not overfill.
5. Reinstall the fill plug. Torque to specification.

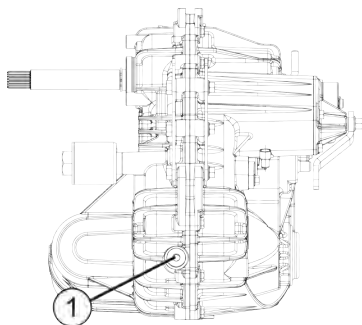



## FLUID CHANGE

The drain plug is located on the bottom of the gearcase. Access the drain plug through the hole in the skid plate.

1. Remove the fill plug.
2. Place a drain pan under the drain plug ②.

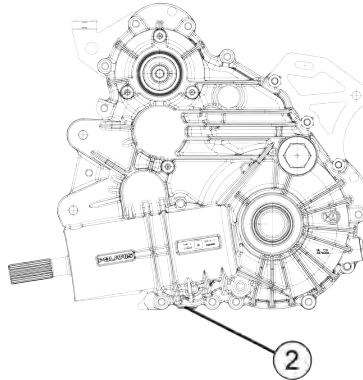

3. Remove the drain plug. Allow the fluid to drain completely.
4. Clean and reinstall the drain plug. Torque to specification.
5. Add the recommended fluid to the bottom of the fill plug hole. Do not overfill.
6. Reinstall the fill plug. Torque to specification.
7. Check for leaks. Discard used fluid properly.

## FRONT GEARCASE (DEMAND DRIVE)

Always check and change the front gearcase oil at the intervals outlined in the POLARIS Maintenance Schedule beginning on page . Maintain the oil level even with the bottom thread of the fill plug hole.

Refer to the Gearcase Specifications Chart for recommended lubricants, capacities and torque specifications. See page 147 for the part numbers of POLARIS products.

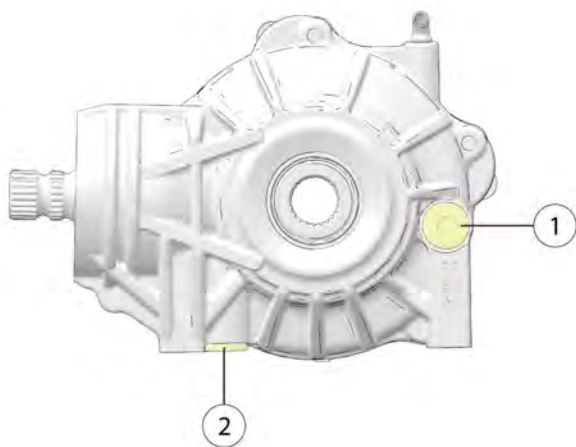

### ***OIL CHECK***

The front gearcase fill plug ① is located on the right side of the front gearcase.

1. Position the vehicle on a level surface.
2. Remove the fill plug. Check the oil level.
3. Add the recommended oil as needed.
4. Reinstall the fill plug. Torque to specification.

### ***OIL CHANGE***

1. Support the vehicle securely with a jackstand.
2. Remove the front tire on the driver's side.
3. Remove the fill plug.
4. Place a drain pan under the drain plug ② on the bottom right-hand side.
5. Remove the drain plug. Drain the oil.
6. Clean and reinstall the drain plug. Torque to specification.
7. Add the recommended fluid to the bottom of the fill plug hole. Do not overfill.
8. Reinstall the fill plug. Torque to specification.
9. Check for leaks.
10. Discard used oil properly.

## MAINTENANCE

# SPARK PLUGS

## SPARK PLUG RECOMMENDATIONS

Refer to the Specifications section for the recommended spark plug type for your vehicle. Always torque spark plugs to specification.

### NOTICE

Using non-recommended spark plugs can result in serious engine damage. Always use POLARIS-recommended spark plugs or their equivalent.

## SPARK PLUG GAP/TORQUE

SPARK PLUG MODEL	ELECTRODE GAP	NEW OR USED PLUG TORQUE
NGK® MR7F	0.7 – 0.8 mm	9 ft-lbs (12 Nm)

### NOTICE

When installing spark plugs into the engine, do not use anti-seize.

## SPARK PLUG INSPECTION

Spark plug condition is indicative of engine operation. The spark plug firing end condition should be read after the engine is warmed up and the vehicle is driven at higher speeds. Immediately check the spark plug for correct color.

### CAUTION

A hot exhaust system and engine can cause burns. Wear protective gloves when removing a spark plug for inspection.

To inspect the spark plug ①, do the following:

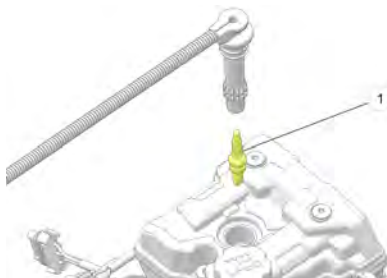

1. Lift the cargo box to access the spark plug.
2. Remove the spark plug cap. Using the spark plug wrench provided in the tool kit, remove the plug by rotating it counter-clockwise.
3. Reverse the procedure for spark plug installation.
4. Torque to specification.

### NOTICE

When reinstalling the spark plug boot onto the spark plug, be sure to place a small amount of dielectric grease in the spark plug boot.

## NORMAL PLUG

The normal insulator tip is gray, tan or light brown. There will be few combustion deposits. The electrodes are not burned or eroded. This indicates the proper type and heat range for the engine and the service.

The tip should not be white. A white insulator tip indicates overheating, caused by use of an improper spark plug or incorrect throttle body adjustments.

## WET FOULED PLUG

The wet fouled insulator tip is black. A damp oil film covers the firing end. There may be a carbon layer over the entire nose. Generally, the electrodes are not worn. General causes of fouling are excessive oil, use of non-recommended oil or poor fuel quality.

## MAINTENANCE

---

### COOLING SYSTEM

The engine coolant level is controlled or maintained by the recovery system. The recovery system components are the overflow bottle, radiator filler neck, radiator pressure cap and connecting hose.

As coolant operating temperature increases, the expanding (heated) excess coolant is forced out of the radiator, past the pressure cap, and into the overflow bottle. As engine coolant temperature decreases, the contracting (cooled) coolant is drawn back up from the tank, past the pressure cap, and into the radiator.

Some coolant level drop on new vehicles is normal as the system is purging itself of trapped air. Observe coolant levels and maintain as recommended by adding coolant to the overflow bottle.

### ADDING OR CHANGING COOLANT

POLARIS recommends the use of POLARIS Antifreeze 50/50 Premix. This antifreeze is already premixed and ready to use. Do not dilute with water.

To ensure that the coolant maintains its ability to protect the engine, we recommend that the system be completely drained every five (5) years and fresh Antifreeze 50/50 Premix added.

Any time the cooling system has been drained for maintenance or repair, replace the coolant with fresh Antifreeze 50/50 Premix. If the recovery bottle has run dry, the level in the radiator should be inspected. Add coolant as needed.

### RADIATOR AND COOLING FAN

Always check and clean the screen and radiator fins at the intervals outlined in the POLARIS Maintenance Schedule. Do not obstruct or deflect air flow through the radiator by installing unauthorized accessories in front of the radiator or behind the cooling fan. Interference with the radiator air flow can lead to overheating and consequent engine damage.

#### NOTICE

Washing the vehicle with a high-pressure hose could damage the radiator fins and impair the radiator's effectiveness. Using a high-pressure system is not recommended.

### RADIATOR COOLANT LEVEL

Always check and clean the screen and radiator fins at the intervals outlined in the POLARIS Maintenance Schedule. Do not obstruct or deflect air flow through the radiator by installing unauthorized accessories in front of the radiator or behind the cooling fan. Interference with the radiator air flow can lead to overheating and consequentially, engine damage.

1. Lift the hood.

## CAUTION

Escaping steam can cause burns. Never remove the pressure cap while the engine is warm or hot. Always allow the engine to cool before removing the pressure cap.

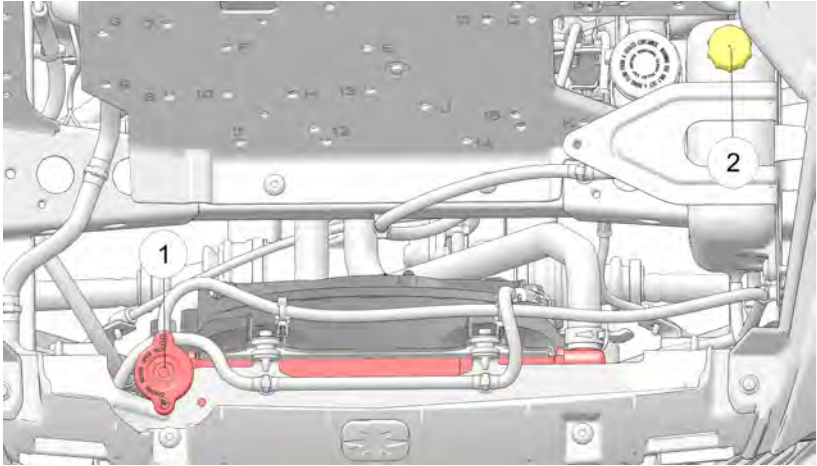

2. Slowly remove the radiator cap ①.
3. View the coolant level through the opening.
4. Use a funnel and slowly add coolant as needed.

## TIP

This procedure is required only if the cooling system has been drained for maintenance and/or repair. But if the overflow bottle ② has run dry, the level in the radiator should also be inspected.

5. Reinstall the pressure cap. Use of a non-standard pressure cap will not allow the recovery system to function properly. Your POLARIS dealer can provide the correct replacement part.

## MAINTENANCE

### OVERFLOW BOTTLE COOLANT LEVEL

Always check and change the coolant at the intervals outlined in the POLARIS Maintenance Schedule. Maintain the coolant level between the minimum and maximum marks on the bottle (when the fluid is cool).

1. Position the vehicle on a level surface.
2. Lift the hood. View the coolant level in the overflow bottle ②.
3. If the coolant level is below the safe operating range, lift the hood and locate the overflow bottle lid. Remove the cap and use a funnel to add coolant through the filler opening. Reinstall the cap.

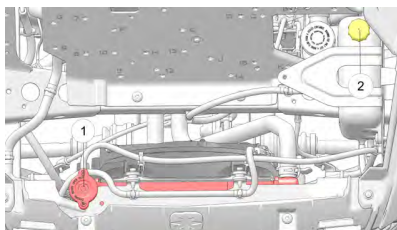

#### TIP

If coolant must be added often, or if the overflow bottle runs completely dry, there may be a leak in the system. Your dealer can inspect the cooling system.

### POLARIS VARIABLE TRANSMISSION (PVT) SYSTEM

#### WARNING

Failure to comply with the instructions in this warning can result in severe injury or death. Do not modify any component of the PVT system. Doing so may reduce its strength so that a failure may occur at a high speed. The PVT system has been precision balanced. Any modification will cause the system to be out of balance, creating vibration and additional loads on components.

The PVT system rotates at high speeds, creating large amounts of force on clutch components. As the owner, you have the following responsibilities for your own safety and the safety of others:

- Always follow all recommended maintenance procedures. Always look for and remove debris inside and around the clutch and vent system when replacing the belt.
- See your dealer or other qualified service person as outlined in the owner's manual.
- This PVT system is intended for use on POLARIS products only. Do not install it in any other product.
- Always make sure the PVT housing is securely in place during operation.



## BELT REMOVAL/DEBRIS REMOVAL

If a belt fails, always clean any debris from the clutch air duct and from the clutch and engine compartments when replacing the belt.

**⚠ WARNING**

Failure to remove ALL debris when replacing the belt could result in vehicle damage, loss of control and severe injury or death.

To replace the belt, do the following:

1. Position the vehicle on a level surface. Place the transmission in park.
2. For ease of access, remove the left rear wheel.
3. Lift the cargo box.
4. Remove the eight (8) fasteners securing the clutch cover ①. Each fastener can be removed using a 8mm socket with ratcheting wrench and extension.

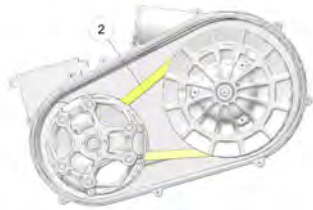
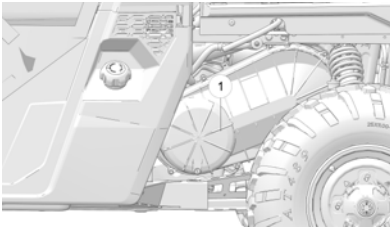

## MAINTENANCE

---

5. Lift the cover over the A-arm assembly.

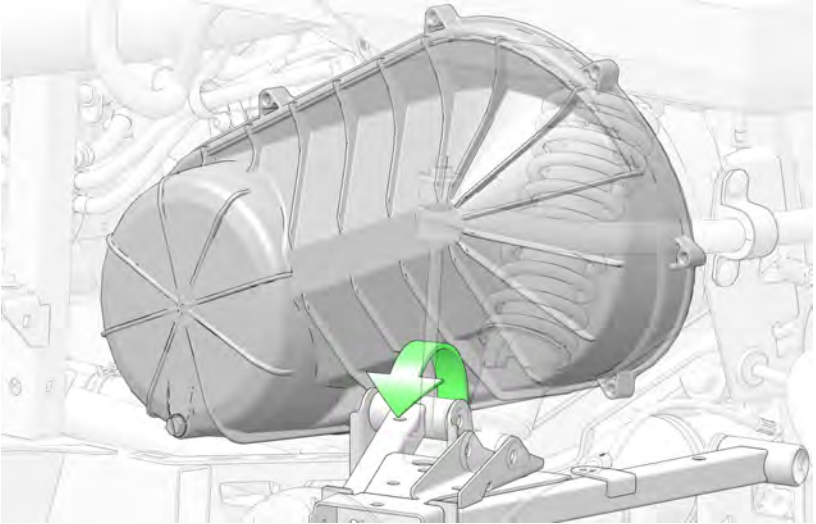

6. Rotate the cover towards the engine.

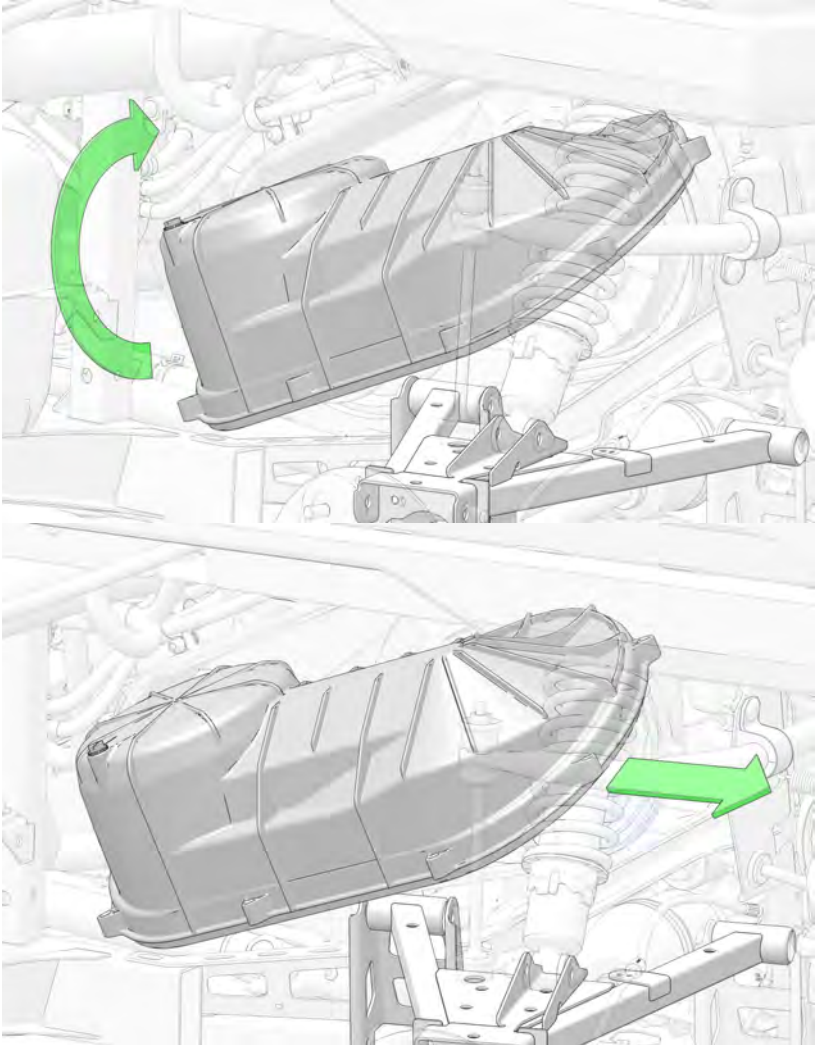

7. Rotate the cover clockwise and remove it from the vehicle.
8. Make sure the cover gasket does not fall out of the groove when removing the cover.
9. Mark the drive belt Ⓜ direction of rotation so that it can be installed in the same direction.

## MAINTENANCE

10. Insert the clutch spreader tool into the threaded hole on the driven clutch as shown and turn clockwise to spread the clutch.

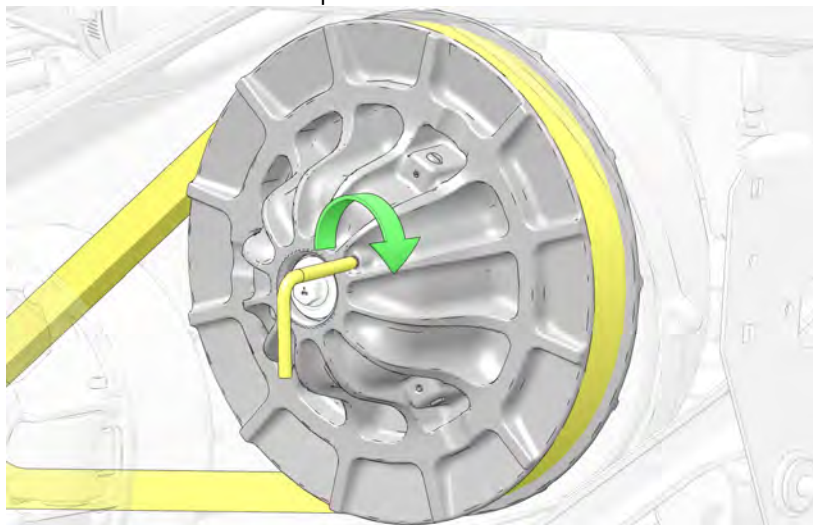

### NOTE

Clutch spreader tool part number 2875911 is found in vehicle tool kit.

11. Walk the belt out of the driven clutch and drive clutch. Remove the belt from the vehicle.
12. Remove all debris wrapped in and around the PVT system.
13. Remove all debris from the entire clutch air duct passage.
14. Check for signs of damage to seals on the transmission and engine. If any seals appear to be damaged, your vehicle requires prompt service. Your POLARIS dealer can assist.

### TIP

Belt slip is responsible for creating excessive heat that destroys belts, wears clutch components and causes outer clutch covers to fail. Switch to low range while operating at slower speeds to extend the life of the PVT components (belt, cover, etc.).

## BELT INSTALLATION

### NOTE

Be sure to install belt in the same direction as it was removed.

1. With the clutch spreader tool installed, loop the belt over the drive clutch and over the driven clutch.

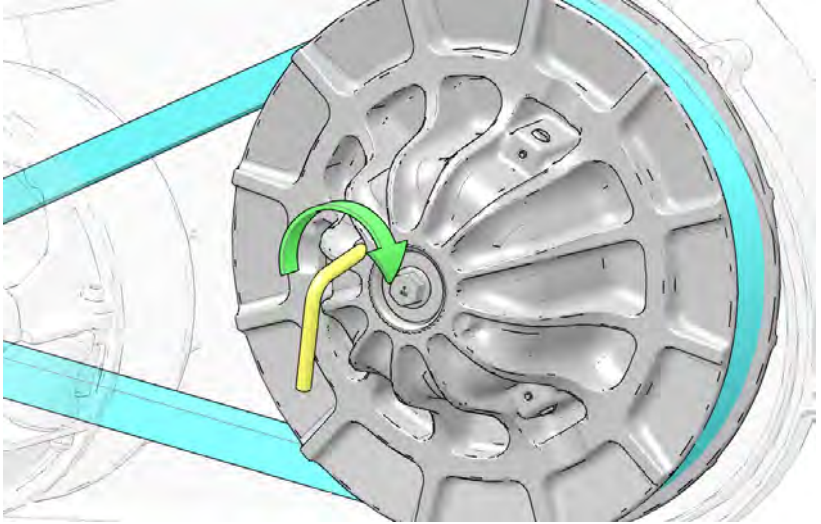

2. Rotate the driven clutch and walk the belt into the clutch.
3. Turn the clutch spreader tool counterclockwise to remove from the driven clutch.
4. Rotate / spin the driven clutch and belt approximately 5-7 times to properly seat the belt in the driven clutch.

## MAINTENANCE

---

5. Remove any debris found in the clutch ducting before reassembly.

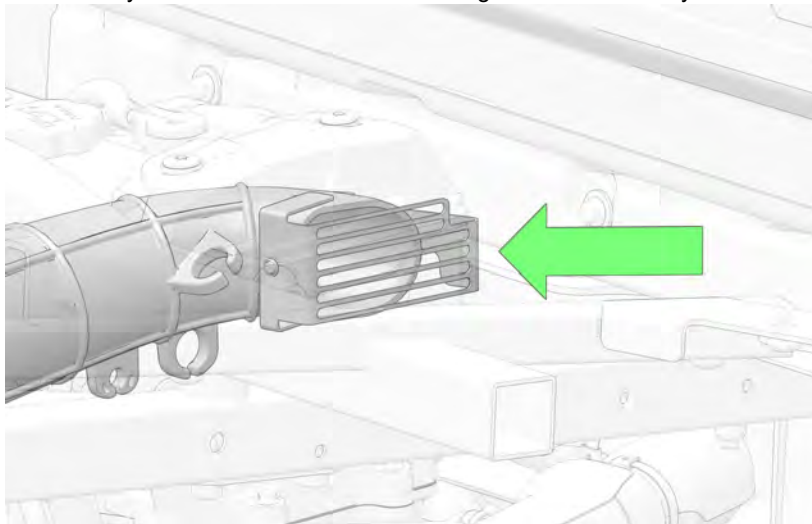

### NOTE

Use care when installing the clutch cover. Do not damage cover, intake boot, or electrical harness.

6. Make sure the PVT cover seal is fully seated and inspect for damage. Replace if necessary.

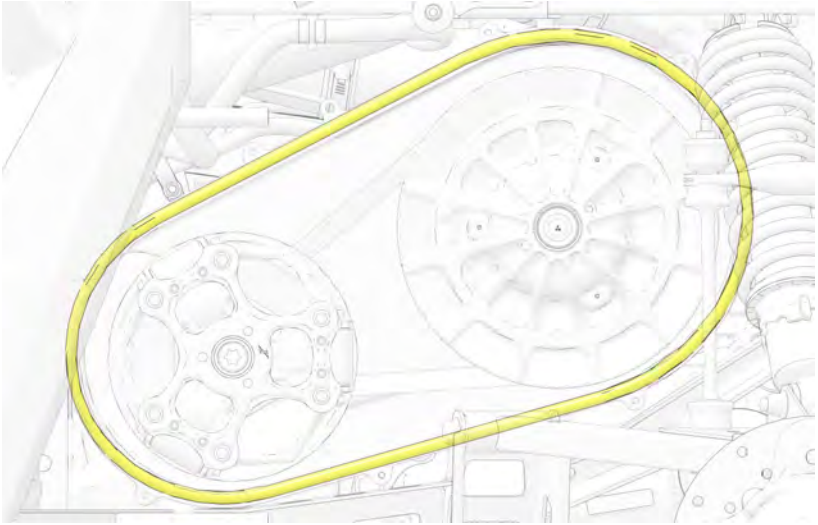

7. Install the cover into the vehicle and rotate counter-clockwise.

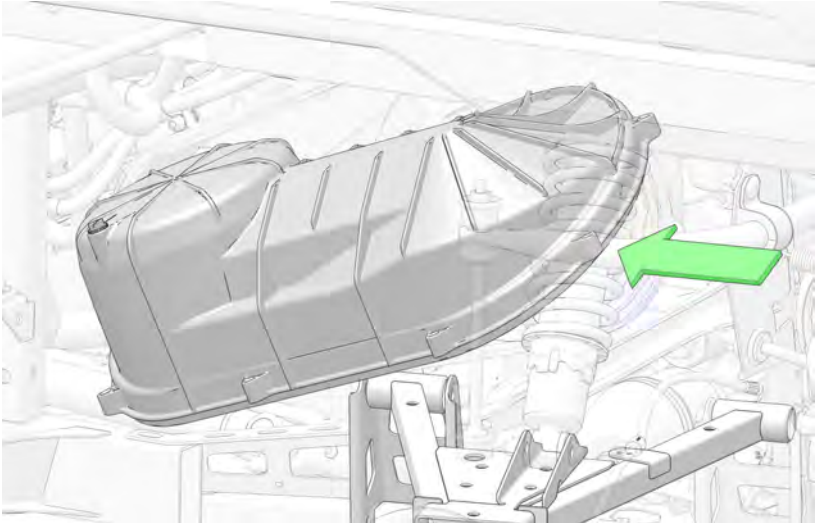

## MAINTENANCE

---

8. Lift the rear of the cover up to the A-arm while simultaneously rotating it away from the engine.

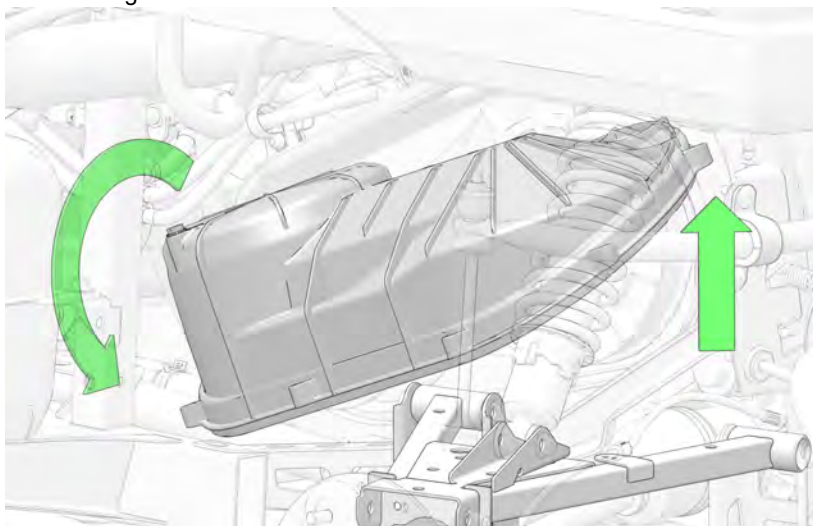



9. Lift the cover over the A-arm assembly and line it up with the mounting holes.

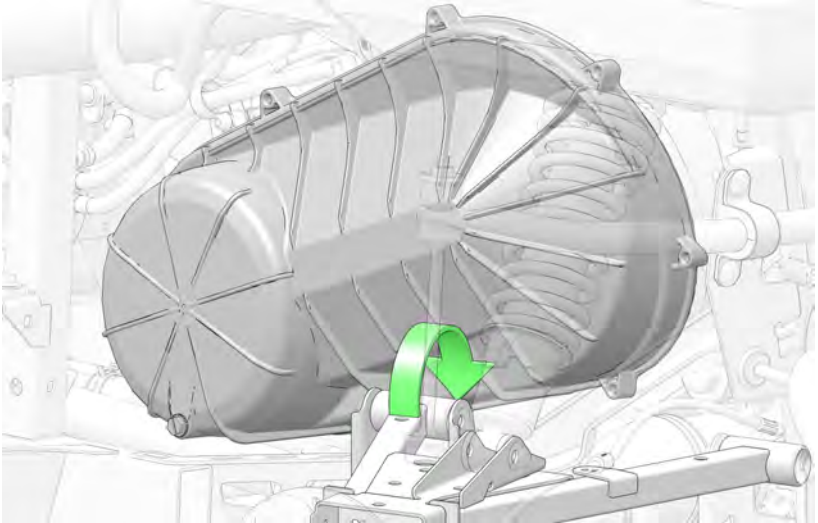

10. Install the eight bolts ① that secure the outer PVT cover to the vehicle. Torque the bolts to specification.

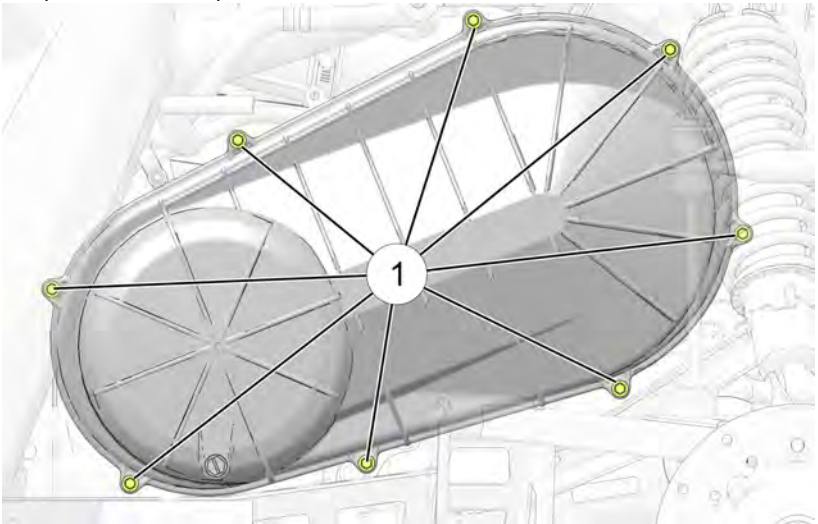

## TORQUE

PVT Outer Cover Fasteners: **44 in-lbs (5 N·m)**

### **POLARIS VARIABLE TRANSMISSION (PVT) SYSTEM DRYING**

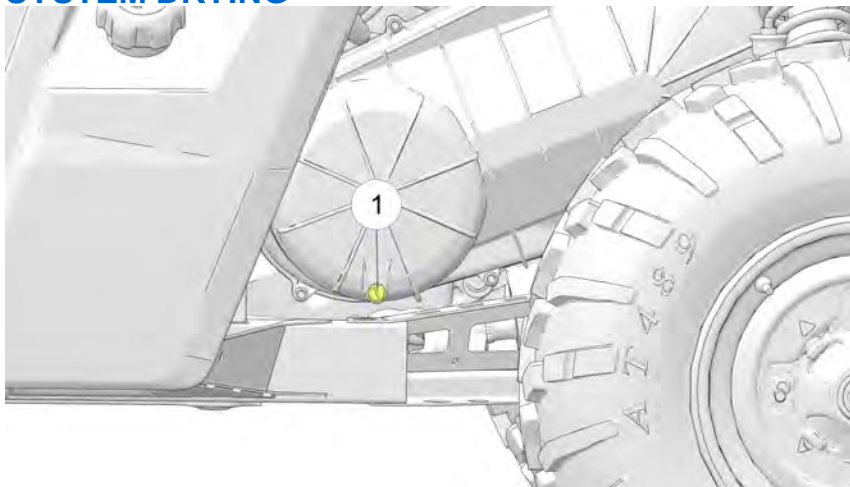

There may be some instances when water is ingested into the PVT system. Use the following instructions to dry it out before operating:

1. Position the vehicle on a level surface.
2. Remove the red drain plug on the outer clutch cover. Allow the water to drain completely. Reinstall the drain plug.
3. Place the transmission in PARK.
4. Start the engine.
5. Apply varying throttle for 10-15 seconds to expel the moisture and air-dry the belt and clutches. Do not hold the throttle wide open for more than five (5) seconds.
6. Allow the engine RPM to settle to idle speed. Apply the brakes. Shift the transmission to the lowest available range.
7. Test for belt slippage. If the belt slips, repeat the process.
8. Your vehicle requires service as soon as possible. Your POLARIS dealer can assist.

---

## VEHICLE IMMERSION

 **WARNING**

If your vehicle becomes immersed, major engine damage can result if the machine is not thoroughly inspected. Take the vehicle in for service before starting the engine. Your POLARIS dealer can provide this service.

If it's impossible to take your *RANGER* to a dealer before starting it, follow the steps outlined below:

1. Move the vehicle to dry land or at the very least, to water below the footrests.
2. Dry any water present in the air box. Filter replacement is required if water is present.
3. Remove the spark plugs. Turn the engine over several times using the electric start.
4. Dry the spark plugs and reinstall, or replace with new plugs.
5. Attempt to start the engine. If necessary, repeat the drying procedure.
6. Take the vehicle in for service as soon as possible, whether you succeed in starting it or not. Your POLARIS dealer can provide the required service.
7. If water has been ingested into the PVT follow the procedure for drying.



## FILTER SYSTEMS

### AIR FILTER

Always change the air filter at the intervals outlined in the Polaris Maintenance Schedule section. Service the air filter more frequently if the vehicle is operated in wet conditions or at high throttle for extended periods.

1. Lift the cargo box.
2. Clean all dirt and debris from the air box area.
3. Unlatch the six (6) cover clips ① and carefully remove the air box cover. Inspect the seal between the cover and air box to ensure the seal is not torn and has been maintaining a proper seal.

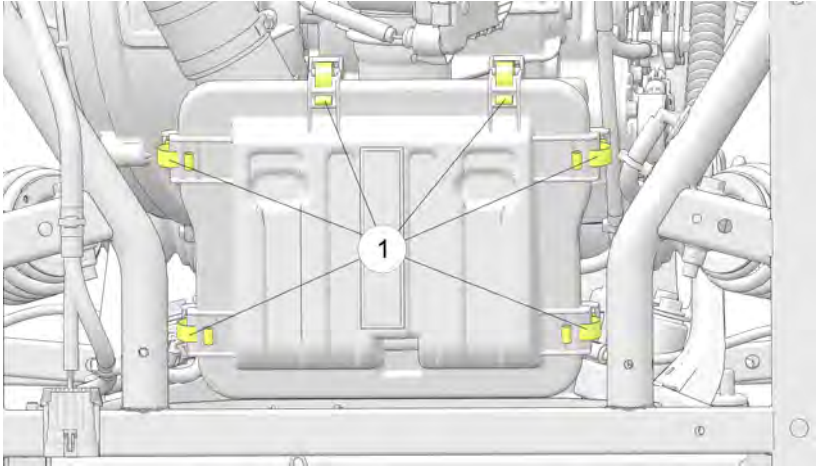

4. Inspect the air filter and air box for dirt, debris, oil or water. If the filter needs to be replaced, remove the worm gear clamp from the filter neck with a flat-blade screwdriver or 6mm socket. Slide the filter rearward to remove it from the boot, then lift it straight upward and out of the air box.
5. With the filter removed, clean the intake boot and air box thoroughly and wipe well with a clean, dry cloth.

#### NOTICE

Dirt or debris in the intake boot could result in severe engine damage. Always clean all dirt and debris from the intake boot before installing the filter.

## MAINTENANCE

---

6. Reinstall the air filter (if clean) or install a new air filter (if soiled). Do not attempt to clean the air filter.

### NOTICE

Use of a non-POLARIS-approved air filter may cause engine damage. Always use a POLARIS-approved replacement filter. See the POLARIS products chapter for part numbers.

7. Make sure the filter is fully seated on the intake boot and that there is no gap between the filter and boot after installation. Tighten the worm gear clamp to 3 Nm (26 in. lbs.).
8. Reinstall the air box cover. Make sure both hinges are fully inserted. Secure the cover clips.

## SPARK ARRESTOR

### WARNING

Failure to heed the following warnings while servicing the spark arrestor could result in serious injury or death.

- Do not perform service on the spark arrestor while the system is hot. Allow components to cool sufficiently before proceeding.
- Wear eye protection and gloves.
- Never operate without the spark arrestor.
- Never run the engine in an enclosed area. Exhaust contains poisonous carbon monoxide gas.

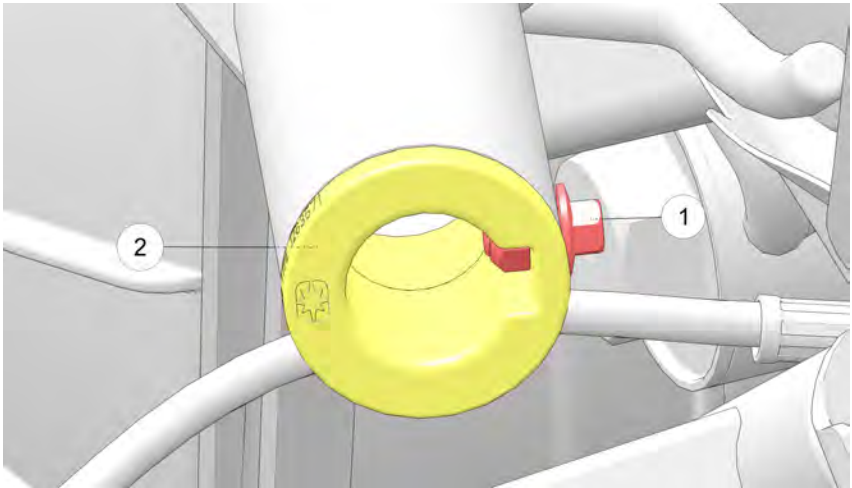

To remove accumulated carbon, clean the spark arrestor at the intervals recommended in the Periodic Maintenance Chart.

1. Remove the bolt ① and nut from the spark arrestor ②. Remove the spark arrestor from the end of the muffler.
2. Use a non-synthetic brush to clean the arrestor screen. A synthetic brush may melt if components are warm. If necessary, blow debris from the screen with compressed air.
3. Inspect the screen for wear and damage. Replace the arrestor if damage is found.
4. Reinstall the arrestor.
5. Torque the bolt and nut to specification.

## TORQUE

Spark Arrestor Bolt  
**10 ft-lbs (14 N·m)**

### BRAKES

The front and rear brakes are hydraulic disc type brakes. Press down on the brake pedal to engage the brakes.

### BRAKE FLUID

Inspect the brake system routinely. Inspect the level of the brake fluid before each operation.

#### WARNING

After opening a bottle of brake fluid, always discard any unused portion. Never store or use a partial bottle. Brake fluid is hygroscopic, meaning it rapidly absorbs moisture from the air. The moisture causes the boiling temperature of the brake fluid to drop, which can lead to early brake fade and the possibility of accident or severe injury.

Change the brake fluid every two years and any time the fluid becomes contaminated, the fluid level is below the minimum, or if the type and brand of the fluid in the reservoir ① are unknown.

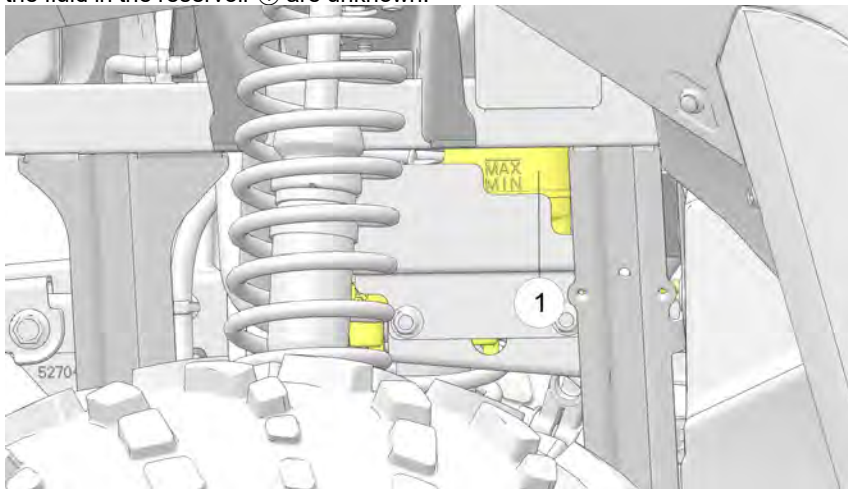

1. Position the vehicle on a level surface.
2. View the brake fluid level at the reservoir in the driver's side wheel well. The level should be between the upper (MAX) and lower (MIN) level lines.
3. If the fluid level is lower than the upper level line, open the hood and add brake fluid to the upper (MAX) line.
4. Apply the brake forcefully for a few seconds and check for fluid leakage around the fittings.



## BRAKE INSPECTION

**⚠ WARNING**

Do not apply WD-40® or any petroleum product to brake discs. These types of products are flammable and may also reduce the friction between the brake pad and caliper.

**⚠ WARNING**

Brake components get hot with prolonged use and can cause burns. Wear protective gloves when inspecting the brakes.

1. Check the brake system for fluid leaks.
2. Check the brake pedal for excessive travel or a spongy feel.
3. Check the friction pads for wear, damage and looseness.
4. Check brake discs for signs of cracks, excessive corrosion, warping or other damage. Clean any grease using an approved brake cleaner or alcohol.
5. Inspect the brake disc spline and pad wear surface for excessive wear. Change pads when worn to 0.762 mm (0.030") ①.

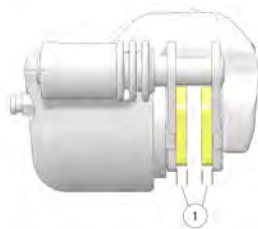

## STEERING WHEEL INSPECTION

Check the steering wheel for specified freeplay and smooth operation at the intervals outlined in the POLARIS Maintenance Schedule.

1. Position the vehicle on level ground.
2. Lightly turn the steering wheel left and right.
3. There should be 20-25 mm (0.8"-1.0") of freeplay.
4. If there is excessive freeplay or strange noises, or the steering feels rough or "catchy," have the steering system inspected by an authorized dealer.

### SPRING ADJUSTMENT

Adjust the front and rear shock absorber springs by rotating the adjustment cam either clockwise or counter-clockwise to increase or decrease spring tension.

- ① Stiffest adjustment setting
- ② Softest adjustment setting

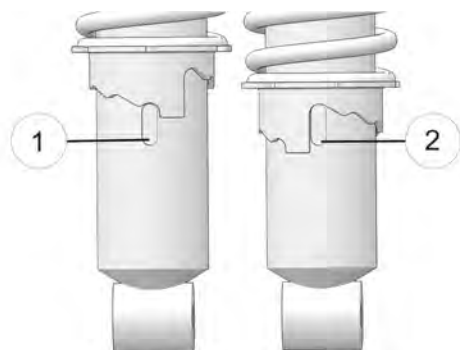

*Always heed the following rules if you make adjustments to this suspension.*

- Always return the suspension to the lowest (softest) setting after the load is removed from the vehicle. The increased suspension height will negatively impact vehicle stability when operating without a load.
- Always apply the same adjustment setting to both sides of the vehicle.

### TIRES

#### WARNING

Operating your vehicle with worn tires will increase the possibility of skidding, loss of control and an accident, which could result in serious injury or death. Always replace tires when the tread depth measures 1/8 in (3 mm) or less.

Improper tire inflation or the use of non-standard size or type of tires may adversely affect vehicle handling, which could result in vehicle damage or personal injury. Always maintain proper tire pressure. Always use POLARIS approved size and type of tires for this vehicle when replacing tires.

#### WARNING

Tires age, even if they have not been used or have only been used occasionally. Cracking of the tread and sidewall rubber, sometimes accompanied by carcass deformation, is an evidence of aging. Old and aged tires must be checked and inspected by tire specialists to ascertain their suitability for further use.

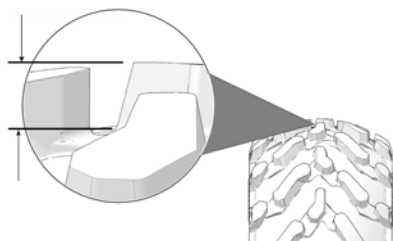

## TIRE TREAD DEPTH

Always replace tires when tread depth is worn to 3 mm (1/8") or less.



## AXLE AND WHEEL NUT TORQUE SPECIFICATIONS

Inspect the following items occasionally for tightness, and if they've been loosened for maintenance service. Do not lubricate the stud or the lug nut.

Lug Nut (Aluminum Wheels) 	Front and Rear	41 Nm (30 ft. lbs.) +90° (1/4 Turn)
Lug Nut (Steel Wheels) 	Front and Rear	49 Nm (36 ft. lbs.)
Hub Retaining Nut	Front	122 Nm (90 ft. lbs.)
	Front-CREW	122 Nm (90 ft. lbs.)
	Rear	150 Nm (111 ft. lbs.)
	Rear-CREW	245 Nm (181 ft. lbs.)

## MAINTENANCE

---

### WHEEL REMOVAL

1. Position the vehicle on a level surface.
2. Place the transmission in PARK. Stop the engine.
3. Loosen the wheel nuts slightly.
4. Elevate the side of the vehicle by placing a suitable stand under the frame.
5. Remove the wheel nuts. Remove the wheel.

### WHEEL INSTALLATION

#### WARNING

Improperly installed wheels can adversely affect tire wear and vehicle handling, which can result in serious injury or death. Always ensure that all nuts are torqued to specification. Do not service axle nuts that have a cotter pin installed. Your dealer can assist.

1. Place the transmission in PARK.
2. Place the wheel on the hub with the valve stem toward the outside and rotation arrows on the tire pointing toward forward rotation.
3. Attach the wheel nuts and finger-tighten.
4. Carefully lower the vehicle to the ground.
5. Torque the wheel nuts to specification.

### POWER STEERING UNIT (IF EQUIPPED)

If your model is equipped with power steering, frequently clean the areas around and on the power steering unit to allow proper cooling. Clean these areas ③ thoroughly.

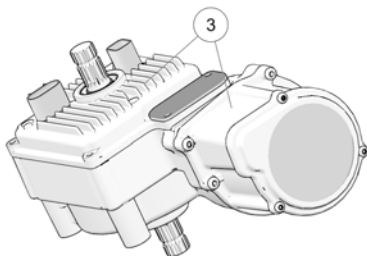

## FUSES

If the engine stops or will not start, or if you experience other electrical failures, a fuse may need replacement. Locate and correct any short circuits that may have caused the blown fuse, then replace the fuse. The fuse box is located under the seat on the passenger side. On CREW models, the fuse box is located under the rear seat on the passenger side. Spare fuses are provided in the fuse box.

If you suspect that a fuse or relay may not be working properly, your dealer can assist.

FUSE SIZE	FEATURE SUPPORTED
20A	Chassis
15A	Lights
10A	Key Switch
10A	Trickle Charge
10A	ECM
15A	Drive
30A	EPS
20A	Accessory
7.5A	Winch
15A	Plug and Power
7.5A	Display
200A (Non-Servicable)	B+

## MAINTENANCE

---

### LIGHTS

Poor lighting can result in reduced visibility when driving. Headlight and taillight lenses become dirty during normal operation. Clean lights frequently and replace burned out lamps promptly. Do not operate this vehicle at night or in low light conditions until the headlight is replaced. Always make sure lights are adjusted properly for best visibility.

When servicing a halogen lamp, don't touch the lamp with bare fingers. Oil from your skin leaves a residue, causing a hot spot that will shorten the life of the lamp.

### HEADLIGHT LAMP REPLACEMENT



**CAUTION**

Hot components can cause burns to skin. Allow lamps to cool before servicing.

To replace the headlight lamp, do the following:

1. Access the headlamp wiring harnesses through the front hood.
2. Unplug the headlamp from the wiring harness. Be sure to pull on the connector ①, not on the wiring.
3. Turn the lamp counter-clockwise to remove it.
4. Install the new lamp.



#### TIP

Make sure the tab on the lamp locates properly in the housing.

5. Reinstall the harness assembly into the headlight assembly.

### ***TAILLIGHT/BRAKE LIGHT/TURN SIGNAL LAMP REPLACEMENT***

The taillight assembly is not serviceable. If the taillight or brake light fails to operate properly, replace the entire taillight assembly.

## HEADLIGHT BEAM ADJUSTMENT

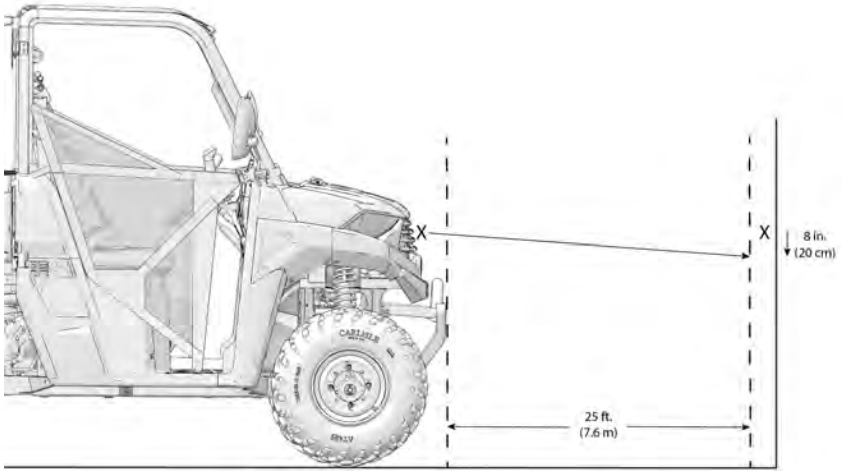

To adjust the headlight beam, do the following:

1. Place the vehicle on a level surface with the headlight approximately 7.6 m (25 ft) from a wall.
2. Measure the distance from the floor to the center of the headlight and make a mark on the wall at the same height.
3. Apply the brakes. Start the engine. Turn on the headlights.
4. Observe the headlight aim. The most intense part of the headlight beam should be aimed 20 cm (8") below the mark placed on the wall. Include the weight of a rider on the seat while performing this step.

## MAINTENANCE

---

5. If a headlight needs adjustment, locate the adjustment screw ① at the rear of the headlight.

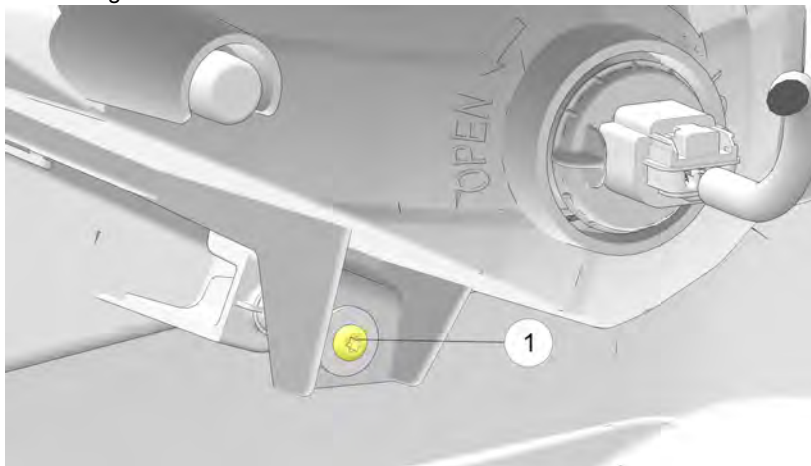

6. Tighten the screw to adjust the lamp up. Loosen the screw to adjust the lamp down.
7. Repeat steps 4-6 until the lamp is properly adjusted.

## BRAKE LIGHTS

When the brake pedal is depressed, the brake light comes on. Check the brake light before each ride.

To check the brake lights, do the following:

1. Turn the key to the ON position.
2. Depress the brake pedal. The brake light should come on after about 0.4 in (10 mm) of pedal travel. If the light doesn't come on, check the bulb.



## BATTERY

### WARNING

Battery electrolyte is poisonous. It contains sulfuric acid. Serious burns can result from contact with skin, eyes or clothing.

Antidote:

**External:** Flush with water.

**Internal:** Drink large quantities of water or milk. Follow with milk of magnesia, beaten egg, or vegetable oil. Call physician immediately.

**Eyes:** Flush with water for 15 minutes and get prompt medical attention.

Batteries produce explosive gases. Keep sparks, flame, cigarettes, etc. away. Ventilate when charging or using in an enclosed space. Always shield eyes when working near batteries. **KEEP OUT OF REACH OF CHILDREN.**

Your vehicle may have either a sealed battery, which requires little maintenance, or a conventional battery. A sealed battery can be identified by its flat covers on the top of the battery. A conventional battery has six filler caps on the top of the battery.

Always keep battery terminals and connections free of corrosion. If cleaning is necessary, remove the corrosion with a stiff wire brush. Wash with a solution of one tablespoon baking soda and one cup water. Rinse well with tap water and dry off with clean shop towels. Coat the terminals with dielectric grease or petroleum jelly. Be careful not to allow cleaning solution or tap water into a conventional battery.

### WARNING

Improperly connecting or disconnecting battery cables can result in an explosion and cause serious injury or death. When removing the battery, always disconnect the negative (black) cable first. When reinstalling the battery, always connect the negative (black) cable last.

## BATTERY REMOVAL

1. Remove the seat to access the battery compartment.
2. On conventional batteries, remove the battery vent tube.
3. Disconnect the black (-) battery cable first. Disconnect the red (+) battery cable last.
4. Remove the battery hold-down strap.
5. Lift the battery out of the vehicle. Be careful not to tip a conventional battery sideways, which could spill electrolyte.

## MAINTENANCE

### NOTICE

If electrolyte spills, immediately wash it off with a solution of one tablespoon baking soda and one cup water to prevent damage to the vehicle.

## BATTERY INSTALLATION

Using a new battery that has not been fully charged can damage the battery and result in a shorter life. It can also hinder vehicle performance.

If your factory-installed 26 AH battery cannot maintain a charge because of operation in extreme cold or with multiple electrical accessories, please see your POLARIS dealer to purchase a 53 AH battery. Before installing the 53AH or 26 Ah battery into the machine, ensure the caps (if equipped) are removed from the battery terminals. Premium battery cables and a battery hold strap may be required.

1. Ensure that the battery is fully charged.
2. Place the fully charged battery in the battery holder.
3. With conventional batteries, install the battery vent tube (sealed batteries do not have a vent tube). The vent tube must be free of obstructions and securely installed. Route the tube away from the frame and vehicle body to prevent contact with electrolyte.

### WARNING

Battery gases could accumulate in an improperly installed vent tube and cause an explosion, resulting in serious injury or death. Always ensure that the vent tube is free of obstructions and is securely installed as recommended.

4. Coat the terminals with dielectric grease or petroleum jelly.
5. Connect and tighten the red (+) cable first. Connect and tighten the black (-) cable last.
6. Verify that cables are properly routed. Cables should be safely tucked away at the front and rear of the battery.
7. Install the battery hold-down strap.

## BATTERY STORAGE

Whenever the vehicle is not used for a period of three months or more, remove the battery from the vehicle, ensure that it's fully charged, and store it out of the sun in a cool, dry place. Check battery voltage each month during storage and recharge as needed to maintain a full charge.

### TIP

Battery charge can be maintained by using a Polaris battery trickle charger or by charging about once a month to make up for normal self discharge. The battery trickle charger can be left connected during the storage period, and will automatically charge the battery if the voltage drops below a predetermined point. See the POLARIS product section of this manual for the part numbers of Polaris products.

## BATTERY CHARGING

The following battery charging instructions apply only to the installation of a sealed battery. Read all instructions before proceeding with the installation of this battery.

The sealed battery is already filled with electrolyte and has been sealed and *fully charged* at the factory. *Never* pry the sealing strip off or add any other fluid to this battery.

The single most important thing about maintaining a sealed battery is to keep it fully charged. Since the battery is sealed and the sealing strip cannot be removed, you must use a voltmeter or multimeter to measure DC voltage.

### WARNING

An overheated battery may explode, causing severe injury or death. Always watch charging times carefully. Stop charging if the battery becomes very warm to the touch. Allow it to cool before resuming charging.

For a refresh charge, follow all instructions carefully.

1. Check the battery voltage with a voltmeter or multimeter. A fully charged battery will register 12.8 V or higher.
2. If the voltage is less than 12.8 volts, recharge the battery at 1.2 amps or less until battery voltage is 12.8 or greater.
3. When using an automatic charger, refer to the charger manufacturer's instructions for recharging. When using a constant current charger, use the guidelines below for recharging.

*Always verify battery condition before and 1-2 hours after the end of charging.*

## MAINTENANCE

STATE OF CHARGE	VOLTAGE	ACTION	CHARGE TIME*
100%	12.8-13.0 volts	None, check at 3 mos. from date of manufacture	None required
75%-100%	12.5-12.8 volts	May need slight charge, if no charge given, check in 3 months	3-6 hours
50%-75%	12.0-12.5 volts	Needs charge	5-11 hours
25%-50%	11.5-12.0 volts	Needs charge	At least 13 hours, verify state of charge
0%-25%	11.5 volts or less	Needs charge with desulfating charger	At least 20 hours

\*(Using constant current charger @ standard amps specified on top of battery)

---

## CLEANING AND STORAGE

### WASHING THE VEHICLE

Keeping your POLARIS vehicle clean will not only improve its appearance but it can also extend the life of various components.

**NOTICE**

High water pressure may damage components. POLARIS recommends washing the vehicle by hand or with a garden hose, using mild soap.

**NOTICE**

Certain products, including insect repellents and chemicals, will damage plastic surfaces. Do not allow these types of products to contact the vehicle.

The best and safest way to clean your POLARIS vehicle is with a garden hose and a pail of mild soap and water.

1. Use a professional-type washing cloth, cleaning the upper body first and the lower parts last.
2. Rinse with clean water frequently.
3. Dry surfaces with a chamois to prevent water spots.

## MAINTENANCE

---

### **WASHING TIPS**

- Avoid the use of harsh cleaners, which can scratch the finish.
- Do not use a power washer to clean the vehicle.
- Do not use medium to heavy duty compounds on the finish.
- Always use clean cloths and pads for cleaning and polishing. Old or reused cloths and pads may contain dirt particles that will scratch the finish.
- Grease all zerk fittings immediately after washing. Allow the engine to run for a while to evaporate any water that may have entered the engine or exhaust system.

If a high pressure water system is used for cleaning (not recommended), exercise extreme caution. The water may damage components and could remove paint and labels. Avoid directing the water stream at the following items:

- Wheel bearings
- Radiator
- Transmission seals
- Brakes
- Door seals (if equipped)
- Cab and body panels
- Labels and decals
- Electrical components and wiring
- Air intake components
- Window seals (if equipped)

If an informational or graphic label becomes illegible or comes off, contact your POLARIS dealer, or other qualified person, to purchase a replacement. Replacement safety labels are provided by POLARIS at no charge.

---

## STORAGE TIPS

### NOTICE

Starting the engine during the storage period will disturb the protective film created by fogging and damage could occur. Never start the engine during the storage period.

### **CLEAN THE EXTERIOR**

Make any necessary repairs and clean the vehicle as recommended.

### **STABILIZE THE FUEL**

1. Fill the fuel tank.
2. Add POLARIS Carbon Clean Fuel Treatment or POLARIS Fuel Stabilizer or equivalent fuel treatments or stabilizers. Follow the instructions on the container for the recommended amount. Carbon Clean removes water from fuel systems, stabilizes fuel and removes carbon deposits from pistons, rings, valves and exhaust systems.
3. Allow the engine to run for 15-20 minutes to allow the stabilizer to disperse through the entire fuel delivery system.

### **OIL AND FILTER**

Change the oil and filter. See the Engine Oil section.

### **AIR FILTER / AIR BOX**

Replace the air filter. See Maintenance Chapter. Clean the air box.

### **FLUID LEVELS**

Inspect the fluid levels. Add or change fluids as recommended in the POLARIS Maintenance Schedule.

- Demand drive fluid (front gearcase)
- Rear gearcase fluid (if equipped)
- Transmission fluid
- Brake fluid (change every two years and any time the fluid looks dark or contaminated)
- Coolant (test strength/fill)

### **INSPECT AND LUBRICATE**

Inspect all cables and lubricate all areas of the vehicle as recommended in the POLARIS Maintenance Schedule.

## MAINTENANCE

---

### **FOG THE ENGINE**

1. Treat the fuel system with POLARIS Carbon Clean or other equivalent fuel treatment. Follow the instructions on the container. Start the engine. Allow it to idle for several minutes so the Carbon Clean reaches the injectors. Stop the engine.
2. Remove the spark plugs and add 1–1.5 oz. (29.5–44 cc.) of engine oil. To access the plug holes, use a section of clear 6 mm (1/4") hose and a small plastic squeeze bottle filled with the pre-measured amount of oil. *Do this carefully! If you miss the plug holes, oil will drain from the spark plug cavities into the hole at the front of the cylinder head, and appear to be an oil leak.*
3. Reinstall the spark plugs. Torque to specification.
4. Apply dielectric grease to the inside of each spark plug cap. *Do not reinstall the cap onto the plug at this step.*
5. Turn the engine over several times. Oil will be forced in and around the piston rings and ring lands, coating the cylinder with a protective film of fresh oil.
6. Reinstall the spark plug caps.
7. If POLARIS fuel system additive is not used, fuel tank, fuel lines, and injectors should be completely drained of gasoline.

### **BATTERY MAINTENANCE**

See page     and page 129 for storage and charging procedures.

### **STORAGE AREA / COVERS**

Be sure the storage area is well ventilated. Cover the vehicle with a genuine POLARIS cover. Do not use plastic or coated materials. They do not allow enough ventilation to prevent condensation, and may promote corrosion and oxidation.

### **REMOVAL FROM STORAGE**



Engine exhaust contains poisonous carbon monoxide and can cause loss of consciousness or death. Never run an engine in an enclosed area.

1. Check the battery electrolyte level and charge the battery if necessary. Install it in the vehicle. Make sure the battery vent hose is routed properly and that it's not pinched or restricted in any way.
2. Make sure spark plugs are tight.
3. Fill the fuel tank with fuel.



4. Check all the points listed in the Daily Pre-Ride Inspection. *Tightness of the bolts, nuts and other fasteners should be checked by an authorized dealer or other qualified service facility.*
5. Lubricate at the intervals outlined in the POLARIS Maintenance Schedule.

## MAINTENANCE

---

### LOADING AND UNLOADING

The weight distribution of the cargo loaded onto the trailer is important and will have an impact on how the vehicle handles on the road. Ensure the weight of the cargo is distributed properly and the trailer is not rear, front, or side heavy.

Always use a spotter if you are uncomfortable loading the vehicle on your own. A wheel chock or marker can also be used as an indication of how close you will park the vehicle from the front of the trailer.

#### WARNING

When loading or unloading a vehicle onto a trailer, always wear the appropriate safety gear, including an approved helmet.

### MINIMUM WORKING LOAD LIMIT

#### WARNING

Always secure cargo properly. Improperly securing a load can result in severe injury or death.

Securing devices, such as tie-down straps, are manufactured to support a load that can be applied during normal service. This is known as the Working Load Limit (WLL).

VEHICLE TYPE	TIE-DOWN MINIMUM WLL
All Vehicles	3,300 lb (1497 kg)

### TRANSPORTING THE VEHICLE

Follow these procedures when transporting the vehicle.

#### NOTICE

Do not tow your vehicle behind a car or other vehicle except on a trailer.

1. Properly load the vehicle onto the trailer or towing vehicle.
2. Apply the brakes.
3. Place the transmission in PARK. Stop the engine.
4. Slowly release the brake pedal and make sure the transmission is in PARK before exiting the vehicle.
5. Remove the key to prevent loss during transporting.
6. Ensure that all seats are attached correctly and are not loose.

7. Secure the fuel cap, and doors (if equipped).

 **WARNING**

Cargo and other loose vehicle parts may fall off while transporting the vehicle. Secure or remove all cargo, and inspect the unit for loose parts prior to transport.

 **WARNING**

Do not exceed the towing vehicle's or trailer's towing capacity when transporting. Refer to the towing vehicle and trailer's specifications.

 **WARNING**

If transporting the vehicle in a non-enclosed trailer, the vehicle must **FACE FORWARD**, or the roof must be removed. Failure to comply may allow airflow, vibration, or other factors to separate the roof from the vehicle and cause an accident, resulting in serious personal injury or death.

## MAINTENANCE

---

8. Using tie-down straps of suitable Working Load Limit (WLL), secure the vehicle to the trailer at the designated tie-down points (front and rear). The straps must be secured in a manner that provides support in both vertical and lateral directions. Ensure that they are set with enough tension as to compress the suspension and prevent vehicle movement during transport. Do not allow the secured straps to make contact with any other part of the trailer or cargo.

 CAUTION

Always use the provided tie-down points. Not using the provided vehicle tie-down points could lead to premature component failure and/or excess wear on the tie-down straps.

 WARNING

Always secure the vehicle with at least four straps when trailering. Use two straps in the front, and two in the rear.

 WARNING

Never use chains to tie down the vehicle.

 WARNING

Do not lay straps over any sharp edges. Sharp edges may damage straps during transportation.

9. Periodically inspect the vehicle and trailer during transit. Adjust cargo and straps as needed to ensure that the cargo cannot shift, or fall from the trailer or towing vehicle.

## TIE-DOWN LOCATIONS

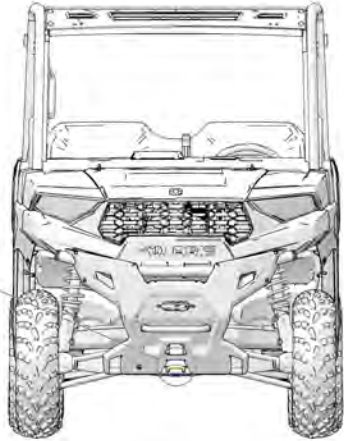
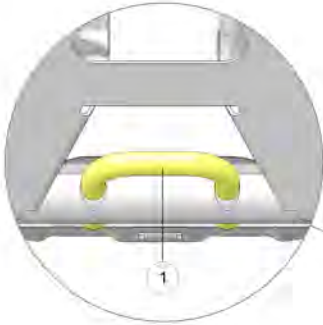

① Front tie-down point

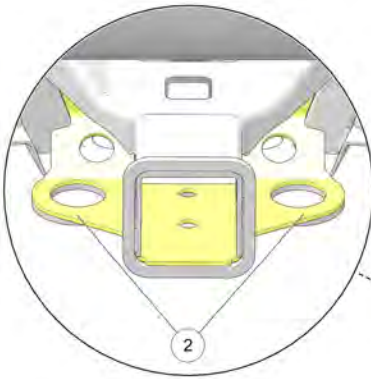

② Rear tie-down points



## SPECIFICATIONS

**RANGER SP 570**

Maximum Weight Capacity (includes weight of operator, passenger, cargo, accessories)	Standard Models: 1000 lbs (454 kg) Premium Models: 925 lbs (420 kg) NorthStar Models: 700 lbs (318 kg)
Dry Weight	Standard Models: 1158 lbs (525 kg) Premium Models: 1245 lbs (565 kg) NorthStar Models: 1502 lbs (681 kg)
Test GVW - Rollover Protection System (ROPS)	2255 lbs. (1023 kg) per OSHA® 29 CFR 1928.53
Fuel Capacity	9.5 gal. (36 L)
Engine Oil Capacity	2 qts. (1.9 L) with filter
Coolant Capacity	5 qts. (4.75 L)
Overall Length	108 in. (290 cm)
Overall Width	Standard/ Premium Models: 56 in. (142.2 cm) Northstar Models: 58 in. (147.3 cm)
Overall Height	74 in. (188 cm)
Wheelbase	73 in. (202 cm)
Cargo Box Dimensions (Inside)	33.3x48.7x12.3 in. (84.5x123.7x31.2 cm)
Ground Clearance	11 in. (27.9 cm) NorthStar Models: 10.5 in. (26.7 cm)
Min. Turning Radius	152 in. (386.7 cm)
Towing Capacity	1500 lbs. (680 kg)
Hitch Tongue Capacity	150 lbs. (68 kg)
Max. Cargo Box Load	500 lbs. (226 kg)
Engine	Dual overhead cam, 4 valve 4 stroke single cylinder.
Displacement	567 cc

## SPECIFICATIONS

Bore x Stroke (mm)	99mm x 73.6mm
Alternator Output	660 W @ 3000 RPM
Compression Ratio	10:1
Starting System	Electric
Fuel System	Electronic Fuel Injection
Ignition Timing	ECU Controlled 32° +/- 2° @ 5000 RPM
Spark Plug	NGK® MR7F / .031" (0.7-0.8 mm)
Lubrication System	Wet Sump
Cooling	Liquid
Front Suspension	MacPherson Ride® Strut w/9 in. (22.9 cm) of travel
Rear Suspension	Dual A-Arm, IRS w/10 in. (25.4 cm) of travel
Throttle Body Size	42 mm
Ignition System	Digital CDI
Driving System Type	PVT
Shift Type	Single Lever (H/L/N/R/P)
Gear Reduction - Low	28.84:1
Gear Reduction - Reverse	25.82:1
Gear Reduction - High	13.57:1
Drive Ratio - Front	3.818:1
Tire Size - Front	25 x 8 x 12
Tire Size - Rear	25 x 10 x 12
Tire Pressure - Front	10 psi (69 kPa)
Tire Pressure - Rear	10 psi (69 kPa)
Brakes, Front/Rear	Foot Activated, 4 wheel hydraulic disc
Headlights	Standard Models: 2 single beam, 55W, quartz/halogen Premium/ NorthStar Models: LED



## SPECIFICATIONS

Taillights	LED
Brake Light	LED

### **RANGER CREW SP 570**

Maximum Weight Capacity (includes weight of operator, passenger, cargo, accessories)	Standard Models: 1225 lbs. (510 Kg) Premium Models: 1100 lbs (499 Kg) NorthStar Models: 750 lbs (340 Kg)
Dry Weight	Standard Models: 1411 lbs. (640 kg) Premium Models: 1550 lbs (703 kg) NorthStar Models: 1900 lbs (861 kg)
Test GVW - Rollover Protection System (ROPS)	2700 lbs. (1224.7 kg) per OSHA® 29 CFR 1928.53
Fuel Capacity	9.5 gal. (36 L)
Engine Oil Capacity	2 qts. (1.9 L) with filter
Coolant Capacity	5 qts. (4.75 L)
Overall Length	144 in. (365.76 cm)
Overall Width	Standard/ Premium Models: 56 in. (142.2 cm) Northstar Models: 58 in. (147.3 cm)
Overall Height	74 in. (188 cm)
Wheelbase	105 in. (266.7 cm)
Cargo Box Dimensions (Inside)	33.3x48.7x12.3 in. (84.5x123.7x31.2 cm)
Ground Clearance	Standard/ Premium Models: 10.5 in. (26.7 cm) NorthStar Models: 10.3 in (26.2 cm)
Min. Turning Radius	196 in (497.8 cm)
Towing Capacity	1500 lbs. (680 kg)
Hitch Tongue Capacity	150 lbs. (68 kg)
Max. Cargo Box Load	500 lbs. (226 kg)
Engine	Dual overhead cam, 4 valve 4 stroke single cylinder.

## SPECIFICATIONS

Displacement	567 cc (570)
Bore x Stroke (mm)	99mm x 73.6mm (570)
Alternator Output	660 W @ 3000 RPM
Compression Ratio	10.5:1
Starting System	Electric
Fuel System	Electronic Fuel Injection
Ignition Timing	ECU Controlled 32° +/- 2° @ 5000 RPM
Spark Plug	NGK® MR7F / .031" (0.7-0.8 mm)
Lubrication System	Wet Sump
Cooling	Liquid
Front Suspension	MacPherson Ride® Strut w/9 in. (22.9 cm) of travel
Rear Suspension	Dual A-Arm, IRS w/10 in. (25.4 cm) of travel
Throttle Body Size	42 mm (570)
Ignition System	Digital CDI
Driving System Type	PVT, 4-wheel independent shaft, lockable differential
Shift Type	Single Lever (H/L/N/R/P)
Gear Reduction - Low	28.84:1
Gear Reduction - Reverse	25.82:1
Gear Reduction - High	13.57:1
Drive Ratio - Front	3.818:1
Tire Size - Front	25 x 8 x 12
Tire Size - Rear	25 x 10 x 12
Tire Pressure - Front	16 psi (110 kPa)
Tire Pressure - Rear	16 psi (110 kPa)
Brakes, Front/Rear	Foot Activated, 4 wheel hydraulic disc

# SPECIFICATIONS

Hood Headlights	Standard Models: 2 single beam, 55W, quartz/halogen Premium/ NorthStar Models: LED
Taillights	LED
Brake Light	LED

## CLUTCHING CHART

CLUTCH SETTINGS				
ALTITUDE meters (feet)	DRIVE CLUTCH		DRIVEN CLUTCH	
	Shift Weight	Clutch Spring	Clutch Spring	Helix
0-1800 (0-6000)	2-Seat: 1327263 (41-77) CREW: 1327263 (41-77)	2-Seat: 7043789 CREW: 7045855	2-Seat: 7045854 CREW: 7045854	2-Seat: 1336970 CREW: 1336970
1800-3700 (6000-12000)	2-Seat: 1327265 (41-68) CREW:- 1327265 (41-68)	2-Seat: 7043789 CREW: 7045855	2-Seat: 7045854 CREW: 7045854	2-Seat: 1336970 CREW: 1336970



# POLARIS PRODUCTS

## PRODUCT INFORMATION

PART NUMBER	DESCRIPTION
<b>Engine Lubricant</b>	
2870791	Fogging Oil (355 ml/12 oz. Aerosol)
2876244	PS-4 Full Synthetic 5W-50 4-Cycle Oil (.95 l/1 qt.)
2876245	PS-4 Full Synthetic 5W-50 4-Cycle Oil (3.8 l/1 gal.)
2878920	PS-4 Extreme Duty Synthetic 10W-50 4-Cycle Oil (.95 l/1 qt.)
2878919	PS-4 Extreme Duty Synthetic 10W-50 4-Cycle Oil (3.8 l/1 gal.)
<b>Gearcase / Transmission Lubricants</b>	
2878068	AGL Full Synthetic Gearcase Lubricant & Transmission Fluid (.95 l/1 qt.)
2878069	AGL Full Synthetic Gearcase Lubricant & Transmission Fluid (3.8 l/1 gal.)
2877922	Demand Drive Fluid (.95 l/1 qt.)
2877923	Demand Drive Fluid (3.8 l/1 gal.)
2870465	Pump for Gallon (3.8 l) Jug
<b>Coolant</b>	
2880514	Antifreeze 50/50 Premix (.95 l/1 qt.)
2880513	Antifreeze 50/50 Premix (3.8 l/1 gal.)
<b>Grease / Specialized Lubricants</b>	
2871312	Grease Gun Kit, All Season Grease
2871322	All Season Grease (89 ml/3 oz. cartridge)
2871423	All Season Grease (414 ml/14 oz. cartridge)
2876160	ATV Angle Drive Fluid (.95 l/1 qt.)
2872276	ATV Angle Drive Fluid (9.5 l/2.5 gal.)
2871460	Premium Starter Grease
2871515	U-Joint Grease (89 ml/3 oz. cartridge)
2871551	U-Joint Grease (414 ml/14 oz. cartridge)
2871329	Dielectric Grease (Nyogel®)
<b>Additives / Miscellaneous</b>	
2871326	Carbon Clean

## POLARIS PRODUCTS

PART NUMBER	DESCRIPTION
2870652	Fuel Stabilizer
2872189	DOT 4 Brake Fluid
2871956	Loctite® 565 Thread Sealant
2830438	BatteryMINDer® 2012 AGM - 2 AMP Charger
5253552	Polaris Battery Strap Bracket for 45 AH Battery
4015591	Polaris 30 AH Battery
2521372	Polaris Air Filter

# TROUBLESHOOTING

## DRIVE BELT WEAR/BURN

POSSIBLE CAUSE	SOLUTION
Driving onto a pickup or tall trailer in high range	Use low range during loading.
Starting out going up a steep incline	Use low range. See warnings in the safety section.
Driving at low RPM or ground speed 5–11 km/h (3-7 MPH)	Drive at a higher speed or use low range more frequently.
Insufficient warm-up at low ambient temperatures	Warm the engine at least 5 minutes. With the transmission in neutral, advance the throttle to about 1/8 throttle in short bursts, 5 to 7 times. The belt will become more flexible and prevent belt burning.
Slow/easy clutch engagement	Use the throttle quickly and effectively.
Towing/pushing at low RPM/low ground speed	Use low range only.
Utility use/plowing	Use low range only.
Stuck in mud or snow	Shift the transmission to low range and carefully use fast, aggressive throttle application to engage clutch. <b>WARNING: Excessive throttle may cause loss of control and vehicle rollover.</b>
Climbing over large objects from a stopped position	Shift the transmission to low range and carefully use fast, brief, aggressive throttle application to engage clutch. <b>WARNING: Excessive throttle may cause loss of control and vehicle rollover.</b>
Belt slippage from water or snow ingestion into the PVT system	Dry out the PVT (see the PVT System Drying section for details). Prevent water from entering the PVT intake duct. See Intake Pre-Filters for more information. Inspect clutch seals for damage if repeated leaking occurs.
Clutch malfunction	Your dealer can assist.
Poor engine performance	Check for fouled plug or foreign material in gas tank or fuel lines. Your POLARIS dealer can assist.
Slippage from failure to warm up belt	Always warm up the belt by operating below 48 km/h for 1.6 km (30 mph for one mile). Warm up for 8 km (5 miles) or more when temperature is below freezing.
Wrong or missing belt	Install the recommended belt.
Improper break-in	Always break in a new belt and/or clutch.

## TROUBLESHOOTING

---

### ENGINE DOESN'T TURN OVER

POSSIBLE CAUSE	SOLUTION
Low battery voltage	Recharge the battery.
Loose battery connections	Check all connections and tighten.
Loose solenoid connections	Check all connections and tighten.
Loose electronic control box connections	Inspect, clean, reinstall connectors.

### ENGINE TURNS OVER, FAILS TO START

POSSIBLE CAUSE	SOLUTION
Out of fuel	Refuel.
Water is present in fuel	Drain the fuel system and refuel.
Old or non-recommended fuel	Replace with fresh recommended fuel.
Fouled or defective spark plug	Inspect plug and replace if necessary.
No spark to spark plug	Inspect plug and replace if necessary.
Water or fuel in crankcase	Your authorized dealer can assist.
Low battery voltage	Recharge the battery to 12.8 VDC.
Mechanical failure	Your authorized dealer can assist.



---

## ENGINE BACKFIRES

POSSIBLE CAUSE	SOLUTION
Weak spark from spark plug	Inspect, clean and/or replace spark plug
Incorrect spark plug gap or heat range	Set gap to specs or replace plug
Old or non-recommended fuel	Replace with fresh recommended fuel
Incorrectly installed spark plug wires	Your authorized dealer can assist
Mechanical failure	Your authorized dealer can assist
Loose ignition connections	Check all connections and tighten
Water present in fuel	Replace with fresh recommended fuel

## ENGINE PINGS OR KNOCKS

POSSIBLE CAUSE	SOLUTION
Poor quality or low octane fuel	Replace with recommended fuel
Incorrect spark plug gap or heat range	Set gap to specs or replace plug

## ENGINE RUNS IRREGULARLY, STALLS OR MISFIRES

POSSIBLE CAUSE	SOLUTION
Fouled or defective spark plug	Inspect, clean and/or replace spark plug
Worn or defective spark plug wires	See your POLARIS dealer
Incorrect spark plug gap or heat range	Set gap to specs or replace plug
Loose ignition connections	Check all connections and tighten
Water present in fuel	Replace with new fuel
Low battery voltage	Recharge battery to 12.8 VDC
Kinked or plugged fuel tank vent line	Inspect and replace
Incorrect fuel	Replace with recommended fuel
Clogged air filter	Inspect and clean or replace
Low fuel pressure	See your POLARIS dealer
Other mechanical failure	See your POLARIS dealer
<b>Possible Lean Fuel Cause</b>	<b>Solution</b>
Low or contaminated fuel	Add or change fuel, clean the fuel system
Low octane fuel	Replace with recommended fuel
Clogged fuel filter	See your POLARIS dealer
<b>Possible Rich Fuel Cause</b>	<b>Solution</b>
Fuel is very high octane	Replace with lower octane fuel

**ENGINE STOPS OR LOSES POWER**

<b>POSSIBLE CAUSE</b>	<b>SOLUTION</b>
Out of fuel	Refuel
Kinked or plugged fuel vent line	Inspect and replace
Water is present in fuel	Replace with new fuel
Fouled or defective spark plug	Inspect, clean and/or replace spark plug
Worn or defective spark plug wires	Your authorized dealer can assist
Incorrect spark plug gap or heat range	Set gap to specs or replace plug
Loose ignition connections	Check all connections and tighten
Low battery voltage	Recharge the battery
Incorrect fuel	Replace with fresh recommended fuel
Clogged air filter	Inspect and clean or replace
Clogged intake pre-filter	Inspect and clean (with soapy water) or replace
Other mechanical failure	Your authorized dealer can assist
Overheated engine	Clean radiator screen and core, clean engine exterior, and check coolant level. Your dealer can assist.



## WARRANTY

### LIMITED WARRANTY

POLARIS Inc., 2100 Highway 55, Medina, MN 55340 (POLARIS) gives a ONE YEAR LIMITED WARRANTY on all components of your POLARIS vehicle against defects in material or workmanship. Laws and regulations in your jurisdiction may give extra protection. POLARIS further warrants that the spark arrester in this product will meet the efficiency requirements of USFS standard 5100-1C for at least 1000 hours when subjected to normal use and when maintenance and installation are in accordance with POLARIS recommendations.

This warranty covers parts and labor charges for repair or replacement of defective parts and begins on the date of purchase by the original retail purchaser. This warranty is transferable to another owner during the warranty period through a POLARIS dealer, but any such transfer will not extend the original term of the warranty. The duration of this warranty may vary by international region based upon local laws and regulations.

### REGISTRATION

At the time of sale, the Warranty Registration Form must be completed by your dealer and submitted to POLARIS within ten days of purchase. Upon receipt of this registration, POLARIS will record the registration for warranty. No verification of registration will be sent to the purchaser as the copy of the Warranty Registration Form will be your proof of warranty coverage. If you have not signed the original registration and received the customer copy, please contact your dealer immediately. **NO WARRANTY COVERAGE WILL BE ALLOWED UNLESS YOUR VEHICLE IS REGISTERED WITH POLARIS.** Initial dealer preparation and set-up of your vehicle is very important in ensuring trouble-free operation. Purchasing a machine in the crate or without proper dealer set-up will void your warranty coverage.

### WARRANTY COVERAGE AND EXCLUSIONS

#### LIMITATIONS OF WARRANTIES AND REMEDIES

This POLARIS limited warranty excludes any failures that are not caused by a defect in material or workmanship. THIS WARRANTY DOES NOT COVER CLAIMS OF DEFECTIVE DESIGN. This warranty also does not cover acts of God, accidental damage, normal wear and tear, abuse or improper handling. This warranty also does not cover any vehicle, component, or part that has been altered structurally, modified, neglected, improperly maintained or used for racing, competition or purposes other than for which it was designed.

This warranty excludes damages or failures resulting from improper lubrication; improper engine timing; improper fuel; surface imperfections caused by external stress, heat, cold or contamination; operator error or abuse; improper component alignment, tension, adjustment or altitude compensation; snow, water, dirt or other foreign substance ingestion/contamination; improper maintenance; modified components; use of aftermarket or unapproved components, accessories, or attachments; use of unapproved software or calibration; unauthorized repairs; or repairs made after the warranty period expires or by an unauthorized repair center.

This warranty excludes damages or failures caused by abuse, accident, fire, or any other cause other than a defect in materials or workmanship and provides no coverage for consumable components, general wear items, or any parts exposed to friction surfaces, stresses, environmental conditions and/or contamination for which they were not designed or not intended, including but not limited to the following items:

- Wheels and tires
- Suspension components
- Brake components
- Seat components
- Clutches and components
- Steering components
- Batteries
- Light bulbs/Sealed beam lamps
- Filters
- Lubricants
- Bushings
- Finished and unfinished surfaces
- Carburetor/Throttle body components
- Engine components
- Drive belts
- Hydraulic components and fluids
- Circuit breakers/Fuses
- Electronic components
- Spark plugs
- Sealants
- Coolants
- Bearings

## LUBRICANTS AND FLUIDS

1. Mixing oil brands or using non-recommended oil may cause engine damage. We recommend the use of POLARIS engine oil.
2. Damage or failure resulting from the use of non-recommended lubricants or fluids is not covered by this warranty.

This warranty provides no coverage for personal loss or expense, including mileage, transportation costs, hotels, meals, shipping or handling fees, product pick-up or delivery, replacement rentals, loss of product use, loss of profits, or loss of vacation or personal time.

THE EXCLUSIVE REMEDY FOR BREACH OF THIS WARRANTY SHALL BE, AT POLARIS' OPTION, REPAIR OR REPLACEMENT OF ANY DEFECTIVE MATERIALS, COMPONENTS, OR PRODUCTS. THE REMEDIES SET FORTH IN THIS WARRANTY ARE THE ONLY REMEDIES AVAILABLE TO ANY PERSON FOR BREACH OF THIS WARRANTY. POLARIS SHALL HAVE NO LIABILITY TO ANY PERSON FOR INCIDENTAL, CONSEQUENTIAL OR SPECIAL DAMAGES OF ANY DESCRIPTION, WHETHER ARISING OUT OF EXPRESS OR IMPLIED WARRANTY OR ANY OTHER CONTRACT, NEGLIGENCE, OR OTHER TORT OR OTHERWISE. THIS EXCLUSION OF CONSEQUENTIAL, INCIDENTAL, AND SPECIAL DAMAGES IS INDEPENDENT FROM AND SHALL SURVIVE ANY FINDING THAT THE EXCLUSIVE REMEDY FAILED OF ITS ESSENTIAL PURPOSE.

THE IMPLIED WARRANTY OF FITNESS FOR A PARTICULAR PURPOSE IS EXCLUDED FROM THIS LIMITED WARRANTY. ALL OTHER IMPLIED WARRANTIES (INCLUDING BUT NOT LIMITED TO THE IMPLIED WARRANTY OF MERCHANTABILITY) ARE LIMITED IN DURATION TO THE ABOVE SIX MONTH WARRANTY PERIOD. POLARIS DISCLAIMS ALL EXPRESS WARRANTIES NOT STATED IN THIS WARRANTY. SOME STATES DO NOT PERMIT THE EXCLUSION OR LIMITATION OF INCIDENTAL OR CONSEQUENTIAL DAMAGES OR ALLOW LIMITATIONS ON THE DURATION OF IMPLIED WARRANTIES, SO THE ABOVE LIMITATIONS MAY NOT APPLY TO YOU IF INCONSISTENT WITH CONTROLLING STATE LAW.

## WARRANTY

---

### **HOW TO OBTAIN WARRANTY SERVICE**

If your vehicle requires warranty service, you must take it to a POLARIS Servicing Dealer. When requesting warranty service you must present your copy of the Warranty Registration Form to the dealer. (THE COST OF TRANSPORTATION TO AND FROM THE DEALER IS YOUR RESPONSIBILITY.) POLARIS suggests that you use your original selling dealer; however, you may use any POLARIS Servicing Dealer to perform warranty service.

### **IN THE COUNTRY WHERE YOUR PRODUCT WAS PURCHASED:**

Warranty or Service Bulletin repairs must be done by an authorized POLARIS dealer, or other qualified person. If you move or are traveling within the country where your product was purchased, Warranty and Service Bulletin repairs may be requested from any authorized POLARIS dealer, or other qualified person, that sells the same line as your product.

### **OUTSIDE THE COUNTRY WHERE YOUR PRODUCT WAS PURCHASED:**

If you are traveling temporarily outside the country where your product was purchased, you should take your product to an authorized POLARIS dealer, or other qualified person. You must show the dealer photo identification from the country of the selling dealer's authorized location as proof of residence. Upon residence verification, the servicing dealer will be authorized to perform the warranty repair.

### **IF YOU MOVE:**

If you move to another country, be sure to contact POLARIS Customer Assistance and the customs department of the destination country before you move. Product importation rules vary considerably from country to country. You may be required to present documentation of your move to POLARIS in order to continue your warranty coverage. You may also be required to obtain documentation from POLARIS in order to register your product in your new country. You should warranty register your product at a local POLARIS dealer in your new country immediately after you move to continue your warranty coverage and to ensure that you receive information and notices regarding your product.

### **IF YOU PURCHASE FROM A PRIVATE PARTY:**

If you purchase a POLARIS product from a private party, to be kept and used outside of the country in which the product was originally purchased, all warranty coverage will be denied. You must nonetheless register your product under your name and address with a local POLARIS dealer in your country to ensure that you receive safety information and notices regarding your product.



## EXPORTED PRODUCTS

EXCEPT WHERE SPECIFICALLY REQUIRED BY LAW, THERE IS NO WARRANTY OR SERVICE BULLETIN COVERAGE ON THIS PRODUCT IF IT IS SOLD OUTSIDE THE COUNTRY OF THE SELLING DEALER'S AUTHORIZED LOCATION. This policy does not apply to products that have received authorization for export from POLARIS. Dealers may not give authorization for export. You should consult an authorized dealer to determine this product's warranty or service coverage if you have any questions. This policy does not apply to products registered to government officials or military personnel on assignment outside the country of the selling dealer's authorized location. This policy does not apply to Safety Bulletins.

## NOTICE

If your product is registered outside of the country where it was purchased and you have not followed the procedure set above, your product will no longer be eligible for warranty or service bulletin coverage of any kind, other than safety recalls. Products registered to government officials or military personnel on assignment outside of the country where the product was purchased will continue to be covered by the Limited Warranty.

Please work with your dealer to resolve any warranty issues. Dealership contacts can be found via this website, if needed:

**[www.polaris.com/en-us/contact](http://www.polaris.com/en-us/contact)**

Should your dealer require any additional assistance, they will contact the appropriate person at POLARIS.

This warranty gives you specific legal rights, and you may also have other rights which vary from state to state or in different countries. If any of the above terms are void because of federal, state, local law, all other warranty terms will remain in effect.

### ***For questions call POLARIS Owner Connections:***

United States & Canada: 1-800-POLARIS (1-800-765-2747)

French: 1-800-268-6334

To report a safety defect to Transport Canada, you may either fill out an online defect complaint form at their website:

English: <http://www.tc.gc.ca/recalls>

French: <http://www.tc.gc.ca/rappels>

Or contact their Defect Investigations and Recalls Division by calling toll-free 1-800-333-0510 (Canada) or 819-994-3328 (Ottawa-Gatineau area / International).

## WARRANTY

---

### U.S.A. EPA EMISSIONS LIMITED WARRANTY

This emissions limited warranty is in addition to the POLARIS standard limited warranty for your vehicle. POLARIS Industries Inc. warrants that at the time it is first purchased, this emissions-certified vehicle is designed, built and equipped so it conforms with applicable U.S. Environmental Protection Agency emission regulations. POLARIS warrants that the vehicle is free from defects in materials and workmanship that would cause it to fail to meet these regulations.

The warranty period for off road vehicles 100cc or greater emissions-certified vehicles starts on the date of purchase by original retail purchaser and continues for a period of 500 hours of engine operation, 5000 kilometers (3100 miles) of vehicle travel, or 30 calendar months from the date of purchase, whichever comes first. The warranty period for ATVs less than 100cc emissions-certified vehicles starts on the date of purchase by original retail purchaser and continues for a period of 250 hours of engine operation, 2500 kilometers (1550 miles) of vehicle travel, or 30 calendar months from the date of purchase, whichever comes first. This EPA emissions warranty period is extended for at least as long as the standard factory warranty that Polaris provides on the vehicle as a whole. The EPA emissions warranty period does not further extend if you purchase additional warranty coverage in the form of a service contract or other paid warranty extension, but emission-related parts may be covered subject to the terms of any such paid service contract or paid warranty extension.

This emissions limited warranty covers components whose failure increases the vehicle's regulated emissions, and it covers components of systems whose only purpose is to control emissions. Repairing or replacing other components not covered by this warranty is the responsibility of the vehicle owner. This emissions limited warranty does not cover components whose failure does not increase the vehicle's regulated emissions.

For exhaust emissions, emission-related components include any engine parts related to the following systems:

- Air-induction system
- Fuel system
- Ignition system
- Exhaust gas recirculation systems

The following parts are also considered emission-related components for exhaust emissions:

- Aftertreatment devices
- Crankcase ventilation valves
- Sensors
- Electronic control units

The following parts are considered emission-related components for evaporative emissions:

- Fuel Tank
- Fuel Cap
- Fuel Line
- Fuel Line Fittings
- Clamps\*
- Pressure Relief Valves\*
- Control Valves\*
- Control Solenoids\*
- Electronic Controls\*
- Vacuum Control Diaphragms\*
- Control Cables\*
- Control Linkages\*
- Purge Valves
- Vapor Hoses
- Liquid/Vapor Separator
- Carbon Canister
- Canister Mounting Brackets
- Carburetor Purge Port Connector

\*As related to the evaporative emission control system.

Emission-related components also include any other part whose only purpose is to reduce emissions or whose failure will increase emissions without significantly degrading engine/equipment performance. The exclusive remedy for breach of this limited warranty shall be, at the exclusive option of POLARIS, repair or replacement of any defective materials, components or products. THE REMEDIES SET FORTH IN THIS LIMITED WARRANTY ARE THE ONLY REMEDIES AVAILABLE TO ANY PERSON FOR BREACH OF THIS WARRANTY. POLARIS SHALL HAVE NO LIABILITY TO ANY PERSON FOR INCIDENTAL, CONSEQUENTIAL OR SPECIAL DAMAGES OF ANY DESCRIPTION, WHETHER ARISING OUT OF EXPRESS OR IMPLIED WARRANTY OR ANY OTHER CONTRACT, NEGLIGENCE OR OTHER TORT OR OTHERWISE. THIS EXCLUSION OF CONSEQUENTIAL, INCIDENTAL, AND SPECIAL DAMAGES IS INDEPENDENT FROM AND SHALL SURVIVE ANY FINDING THAT THE EXCLUSIVE REMEDY FAILED OF ITS ESSENTIAL PURPOSE.

ALL IMPLIED WARRANTIES (INCLUDING BUT NOT LIMITED TO ANY IMPLIED WARRANTIES OF MERCHANTABILITY AND FITNESS FOR A PARTICULAR PURPOSE) ARE LIMITED IN DURATION TO THE WARRANTY PERIOD DESCRIBED HEREIN. POLARIS DISCLAIMS ALL EXPRESS WARRANTIES NOT STATED IN THIS WARRANTY. Some states do not allow limitations on how long an implied warranty lasts, so the above limitation may not apply if it is inconsistent with the controlling state law.

This limited warranty excludes failures not caused by a defect in material or workmanship. This limited warranty does not cover damage due to accidents, abuse or improper handling, maintenance or use. This limited warranty also does not cover any engine that has been structurally altered, or when the vehicle has been used in racing competition. This limited warranty also does not cover physical damage, corrosion or defects caused by fire, explosions or other similar causes beyond the control of POLARIS.

## WARRANTY

---

Owners are responsible for performing the scheduled maintenance identified in the owner's manual. POLARIS may deny warranty claims for failures that have been caused by the owner's or operator's improper maintenance or use, by accidents for which POLARIS has no responsibility, or by acts of God.

Any qualified repair shop or person may maintain, replace, or repair the emission control devices or systems on your vehicle. An authorized POLARIS dealer, or other qualified person, can perform any service that may be necessary for your vehicle. POLARIS also recommends POLARIS parts, however equivalent parts may be used for such service. It is a potential violation of the Clean Air Act if a part supplied by an aftermarket parts manufacturer reduces the effectiveness of the vehicle's emission controls. Tampering with emission controls is prohibited by federal law.

## CALIFORNIA RESIDENTS

Certain POLARIS Off-Road Vehicles are available in 49-state and 50-state versions. Only the 50-state models are certified for sale in California. The 50-state models available for sale in California are identified by the letter "B" in the ninth position of the model number (e.g., R16RTE87B). The POLARIS 50-state models are designed and built with features such as a reduced cargo box capacity. Any modifications to these features may be a violation of the applicable California regulations and may void this limited emissions warranty offered by the manufacturer.

POLARIS Inc. warrants that at the time is first purchased, this vehicle is:

1. Designed, built, and equipped so as to conform, at the time of sale, with all applicable California evaporative emissions regulations.
2. Free from defects in material and workmanship that may cause the failure of a warranted part as defined in California evaporative emissions regulations. All replacement parts must be identical in all material respects to that part as described in the OHRV manufacturer's Executive Order of Certification application.

The California evaporative emissions control system limited warranty statement below applies to your Off Highway Recreational Vehicle in California if the vehicle is equipped with an evaporative emission control system and is labeled with a Vehicle Evaporative Emissions Control Information label indicating that the vehicle conforms to California evaporative emissions regulations applicable to new off-road sport vehicles, all-terrain vehicles, or off-road utility vehicles. These vehicles are referred to as "OHRV-EVAP" below.

### **CALIFORNIA EMISSION CONTROL WARRANTY STATEMENT YOUR WARRANTY RIGHTS AND OBLIGATIONS**

The California Air Resources Board and Polaris Industries Inc. are pleased to explain the emission control system warranty on your model year 2018 and newer Off Highway Recreational Vehicle. In California, new off-highway recreational vehicles must be designed, built and equipped to meet the State's stringent anti-smog standards. Polaris must warrant the emission control system on your OHRV-EVAP for the periods of time listed below provided there has been no abuse, neglect or improper maintenance of your OHRV-EVAP.

Your emission control system may include parts such as the carburetor or fuel injection system, fuel tank, fuel hoses, carbon canister, engine computer and Evaporative Emissions Control System parts listed in the U.S.A. EPA Emissions Limited Warranty. Also included may be hoses, belts, connectors and other emission-related assemblies. Where a warrantable condition exists, Polaris will repair your OHRV-EVAP at no cost to you including diagnosis, parts and labor.

### **MANUFACTURER'S WARRANTY COVERAGE:**

For model year 2018 and newer OHRV-EVAP models.

For 30 months, or 2500 miles (4023 km), or 250 hours, whichever comes first, except for evaporative components over the OHRV high-priced warranty value, which is covered for 60 months, or 5000 miles (8047 km), or 500 hours, whichever comes first.

If any emission-related part on your OHRV-EVAP is defective, the part will be repaired or replaced by Polaris.

### **OWNER'S WARRANTY RESPONSIBILITIES:**

As the OHRV-EVAP owner, you are responsible for the performance of the required maintenance listed in your owner's manual. Polaris recommends that you retain all receipts covering maintenance on your OHRV-EVAP, but Polaris cannot deny warranty solely for the lack of receipts or for your failure to ensure the performance of a scheduled maintenance.

As an owner you are responsible for presenting your OHRV-EVAP to a Polaris dealer as soon as a problem exists. The warranty repairs should be completed in a reasonable amount of time, not to exceed 30 days.

As an OHRV-EVAP owner, you should also be aware that Polaris may deny you warranty coverage if your OHRV-EVAP or a part has failed due to abuse, neglect, improper maintenance or unapproved modifications.

### **ADD-ON OR MODIFIED PARTS**

An add-on or modified part must be compliant with applicable CARB emission control standards. A violation of this requirement is punishable by civil and/or criminal punishment.

If you have any questions regarding your warranty rights and responsibilities, you should contact Polaris Customer Assistance at 1-800-POLARIS (1-800-765-2747) or the California Air Resources Board at 9528 Telstar Avenue, El Monte, CA 91731.

# WARRANTY

---

United States & Canada: 1-800-POLARIS (1-800-765-2747)

French: 1-800-268-6334







---

<b>A</b>		Dumping the Cargo Box ..... 74
Adding or Changing Coolant ..... 100		
Adjustable Steering Wheel ..... 35		
Air Filter.....115		
Air Filter / Air Box..... 133		
All Wheel Drive/Rear Differential System ..... 76		
Auxiliary Outlet..... 36		
AWD.....39		
Axle and Wheel Nut Torque Specifications..... 121		
<b>B</b>		
Battery ..... 127		
Battery Charging ..... 129		
Battery Installation ..... 128		
Battery Maintenance ..... 134		
Battery Removal..... 127		
Battery Storage ..... 129		
Battery Trickle-Charging Outlet..... 36		
Belt Removal PVT Debris Removal ..... 103		
Brake Lights ..... 126		
Brakes ..... 118		
Braking ..... 71		
<b>C</b>		
Cab Nets ..... 44		
California Residents ..... 162		
Clean the Exterior ..... 133		
Component Locations..... 33		
Console, NORTHSTAR Models Only ..... 35		
Console, Standard ..... 34		
Cooling System..... 100		
<b>D</b>		
Diagnostic Display Code Definitions ..... 53		
Drive Belt Wear/Burn..... 149		
Driveline Mode Switch ..... 39		
<b>E</b>		
Electromagnetic Interference ..... 79		
Electronic Power Steering ..... 43		
Engine and Drivetrain Break-in ..... 68		
Engine Backfires ..... 151		
Engine Doesn't Turn Over ..... 150		
Engine Oil..... 87		
Engine Pings or Knocks ..... 151		
Engine Runs Irregularly, Stalls or Misfires ..... 152		
Engine Stops or Loses Power .... 153		
Engine Turns Over, Fails to Start..... 150		
Exhaust Emission Control System ..... 79		
Exported Products ..... 159		
<b>F</b>		
Fan, Cooling..... 100		
Fluid Levels..... 133		
Fog the Engine ..... 134		
Front Gearcase (Demand Drive) ... 95		
Fuel Cap..... 43		
Fuel Recommendations ..... 67		
Fuel Stabilizer..... 133		
Fuses ..... 123		
<b>G</b>		
Gear Selector ..... 37		
Gearcase Specification Chart..... 92		
<b>H</b>		
Hauling Cargo..... 72		
Headlight Beam Adjustment..... 125		
Headlight Lamp Replacement .... 124		
How To Obtain Warranty Service ..... 158		

---

---

**I**

Ignition Switch .....	38
Inspect and Lubricate .....	133
Instrument Cluster	
Back Light Color .....	61
Back Light Level .....	62
Clock .....	60
Diagnostic Code .....	52
Display Area 1 .....	49
Display Area 2 .....	50
Indicator Lamps .....	47
Options Menu .....	51
Overview .....	46
Service Hours .....	63
Unit Selection Distance .....	58
Unit Selection Temperature .....	59

**L**

Labels	
Air Filter Caution .....	32
Belt Warning .....	25
Clutch Cover Warning .....	31
Fuel Transport Warning .....	32
Maximum Payload Warning .....	31
Passenger/ Tire Pressure Warning .....	28
Proper Use Warning .....	26-27
Seat Belt/ Drive Responsibly Warning .....	30
Lights .....	124
Limited Warranty .....	155
Lubrication Recommendations .....	86

**M**

Maintenance	
Oil and Filter Change .....	89
Oil Check .....	87
Maintenance Log .....	165
Maintenance Overview .....	81
Mode Button .....	38

**N**

Near Field Communication (NFC) .....	10
Noise Emission Control System .....	79
Notice .....	159

**O**

Oil and Filter .....	133
Overflow Bottle Coolant Level .....	102

**P**

PIN Activated Security System (P.A. S.S.) (if equipped)	
Instrument Cluster .....	63
Plugs, Spark .....	98
Polaris Products .....	147
POLARIS Variable Transmission (PVT) System Drying .....	112
POLARIS Variable Transmission System .....	102
Power Steering .....	43
Power Steering Unit (Cleaning) .....	122
Pre-Ride Inspection .....	68
PVT Belt Installation .....	106
PVT Break-in (Clutches/Belt) .....	68
PVT System Clutching Chart .....	145

**R**

Radiator and Cooling Fan .....	100
Radiator Coolant Level .....	100
Registration, Warranty .....	155
Removal from Storage .....	134
Rollover Protective Structure (ROPS) .....	45

**S**

Safety

---

Driver and Passenger	
Qualifications .....	12
Driving Guidelines .....	18
Owner Requirements .....	11
Prepare Vehicle for the Ride .....	13
Prepare Yourself, Passengers, and	
Cargo for the Ride .....	16
Safety Labels and Locations .....	25
Safety Symbols .....	8
Seat and Storage	
Compartments .....	42
Seat Belt .....	41
Seat Removal .....	42
Signal Words .....	8
Spark Arrestor .....	79
Spark Arrestor .....	116
Spark Plug Gap/Torque .....	98
Spark Plug Inspection .....	98
Spark Plug Recommendations .....	98
Specifications .....	141
CREW .....	143
Spring Adjustment .....	120
Stabilize the Fuel .....	133
Starting the Engine .....	69
Steering Wheel Inspection .....	119
Stopping the Engine .....	70
Storage .....	133
Storage Area .....	134
Suspension Adjustment .....	120

## T

Tail Lamp Replacement .....	124
Tire Tread Depth .....	121
Tires .....	120
Towing a Ranger .....	73
Towing Loads .....	73
Trailer Hitch Bracket .....	45
Transmission .....	93
Transporting the Vehicle .....	136

## U

U.S.A. EPA Emissions Limited	
Warranty .....	160
USB Outlet .....	37

## V

Vehicle Break-in Period .....	67
Vehicle Identification Numbers .....	9
Vehicle Immersion .....	113
Vehicle Tie-Down	
Loading and unloading .....	136
Minimum Working Load Limit	
(WLL) .....	136
Tie Down Locations .....	139

## W

Warning Symbols .....	8
Washing the Vehicle .....	131
Welcome Page .....	3
Wet Fouled Plug .....	99
Wheel Installation .....	122
Wheel Removal .....	122





For your nearest Polaris dealer,  
call 1-800-POLARIS (765-2747)  
or visit [www.polaris.com](http://www.polaris.com)

Polaris Inc.  
2100 Highway 55  
Medina, MN 55340



Part No. 9940856 Rev 03  
Printed in USA