

2023



For Maintenance and Safety

OWNER'S MANUAL

RANGER Diesel

WARNING

Read this manual carefully. It contains important safety information. This is an adult vehicle only.

Operation is prohibited for those under 16 years of age.

POLARIS
Think Outside



WARNING

Read, understand, and follow all of the instructions and safety precautions in this manual and on all product labels.

Failure to follow the safety precautions could result in serious injury or death.



For videos and more information about a safe riding experience with your Polaris vehicle, scan this QR Code[®] with your smartphone.

POLARIS
RANGER[®]

2023 Owner's Manual

RANGER Diesel Tractor
RANGER Diesel MD
RANGER Diesel ISRAEL

Unless noted, trademarks are the property of Polaris Industries Inc.

Recreational Off-Highway Vehicle Association® and ROHVA® are registered trademarks of Recreational Off-Highway Vehicle Association. Tread Lightly® is a registered trademark of the United States Department of Agriculture. BatteryMINDer® is a registered trademark of VDC Electronics Inc. Loctite® is a registered trademark of Henkel Corporation. NYOGEL® is a registered trademark of Nye Lubricants, Inc. WD-40® is registered to WD-40 Manufacturing Company. QR Code® is a registered trademark of DENSO WAVE INCORPORATED. Maxxis® is a registered trademark of Cheng Shin Rubber Ind. Co., Ltd. OSHA® is a registered trademark of the Occupational Safety and Health Administration, U.S. Department of Labor. Apple® and App Store® are registered trademarks of Apple Inc. Google Play® is a registered trademark of Google LLC. MACPHERSON RIDE® is a registered trademark of Aftermarket Auto Parts Alliance, Inc. Carlisle® is a registered trademark of CARLISLE INTANGIBLE, LLC.

Copyright 2022 Polaris Industries Inc. All information contained within this publication is based on the latest product information at the time of publication. Due to constant improvements in the design and quality of production components, some minor discrepancies may result between the actual vehicle and the information presented in this publication. Depictions and/or procedures in this publication are intended for reference use only. No liability can be accepted for omissions or inaccuracies. Any reprinting or reuse of the depictions and/or procedures contained within, whether whole or in part, is expressly prohibited.

The original instructions for this vehicle are in English. Other languages are provided as translations of the original instructions.

Printed in Czech Republic

9940850 REV 01



Thank you for purchasing a POLARIS vehicle, and welcome to our world-wide family of POLARIS enthusiasts. Be sure to visit us online at www.polaris.com for the latest news, new product introductions, upcoming events, career opportunities and more.

Here at POLARIS we proudly produce an exciting line of utility and recreational products. We believe POLARIS sets a standard of excellence for all utility and recreational vehicles manufactured in the world today. Many years of experience have gone into the engineering, design, and development of your POLARIS vehicle, making it the finest machine we've ever produced.

For safe and enjoyable operation of your vehicle, be sure to follow the instructions and recommendations in this owner's manual. Your manual contains instructions for minor maintenance, but information about major repairs is outlined in the POLARIS Service Manual and can be performed by a factory certified Master Service Dealer (MSD) technician.

Your POLARIS dealer knows your vehicle best and is interested in your total satisfaction. Your POLARIS dealership can perform all of your service needs during and after the warranty period.

For the most up-to-date owner's manual visit <https://www.polaris.com/en-us/owners-manuals>.

WELCOME

Introduction	7
IMPORTANT ISRAEL MODEL INFORMATION	15
Safety	19
Features and Controls	43
Operation	77
Emission Control Systems	95
Maintenance	97
Specifications	161
POLARIS Products	167
Troubleshooting	169
Warranty	175
Maintenance Log	181

INTRODUCTION

IMPORTANT INFORMATION

 **WARNING**

Failure to follow the warnings contained in this manual can result in severe injury or death.

This vehicle is not a toy and can be hazardous to operate. This vehicle handles differently than other vehicles. A collision or rollover can occur quickly, even during routine maneuvers, if you fail to take proper precautions.

- Read this owner's manual. Understand all safety warnings, precautions and operating procedures before operating the vehicle. Keep this manual with the vehicle at all times.
- This vehicle is an **ADULT VEHICLE ONLY**. You **MUST** be at least 16 years of age and have a valid driver's license to operate this vehicle.
- No person under the age of 12 may ride as a passenger in this vehicle.
- Never permit a guest to operate this vehicle unless the guest has read this manual and all product labels.
- Always keep hands, feet, and all other body parts inside the vehicle at all times.
- Always wear the proper clothing when operating or riding in this vehicle. All riders should wear substantial footwear, long pants, and a close-fitting shirt. A hard hat or helmet and approved eye protection are recommended when appropriate for riding or working conditions.
- Never operate this vehicle under the influence of drugs or alcohol, as these conditions impair judgement and the operator's ability to react.

INTRODUCTION

TOOLS FOR SAFE RIDING

To safely operate this vehicle, it is important to become familiar with its features, controls, and characteristics. Review the Safety Briefings for this vehicle that apply to you:

- Operators
- Riders
- Owners
- Trailering the Vehicle
- Maintaining the Vehicle

Additionally, read the product safety labels on the vehicle and follow all rules and regulations concerning the operation of this vehicle in your area.

POLARIS recommends anyone who will be operating this vehicle to take a training course. ROHVA® (Recreational Off-Highway Vehicle Association®) provides both an online safety e-course and a hands-on safety course. To access this training, visit www.rohva.org.

Other sources of safety information include the POLARIS Safety Video. The POLARIS Help Center also has additional information: <https://polaris.com/en-us/self-help>

SAFETY SYMBOLS AND SIGNAL WORDS

The following signal words and symbols appear throughout this manual and on your vehicle. Your safety is involved when these words and symbols are used. Become familiar with their meanings before reading the manual.

 **DANGER**

DANGER indicates a hazardous situation which, if not avoided, WILL result in death or serious injury.

 **WARNING**

WARNING indicates a hazardous situation which, if not avoided, COULD result in death or serious injury.

 **CAUTION**

CAUTION indicates a hazardous situation which, if not avoided, COULD result in minor to moderate injury.

NOTICE

NOTICE provides key information by clarifying instructions.

IMPORTANT

IMPORTANT provides key reminders during disassembly, assembly, and inspection of components.

The Prohibition Safety Sign indicates an action NOT to take in order to avoid a hazard.



The Mandatory Action Sign indicates an action that NEEDS to be taken to avoid a hazard.



INTRODUCTION

VEHICLE IDENTIFICATION NUMBERS

Record your vehicle's identification numbers and key number in the spaces provided. Remove the spare key and store it in a safe place. An ignition key can be duplicated only by ordering a POLARIS key blank (using your key number) and mating it with one of your existing keys. The ignition switch must be replaced if all keys are lost.

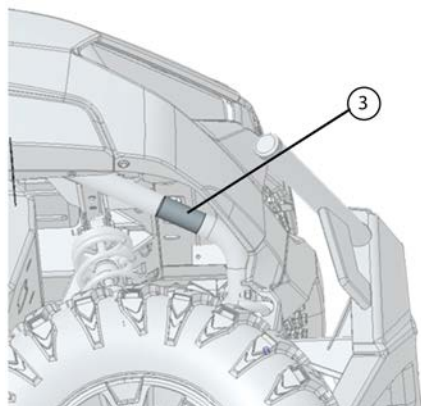
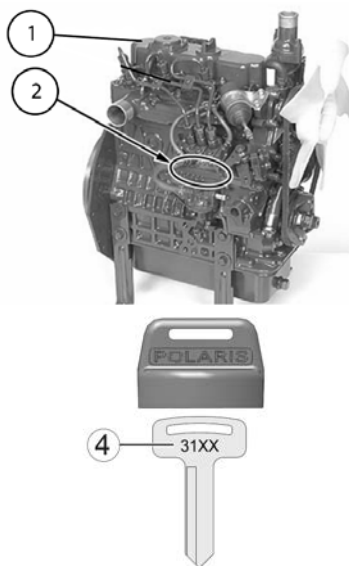

The engine serial number can be found on a decal applied to the rocker cover near the fill cap ① or stamped into the crankcase near the injection pump ②.

The VIN can be found on the vehicle's frame, just above the right front wheel ③. The key number can be found on the key ④.

Vehicle Model Number:	
Vehicle Identification Number (VIN):	
Engine Serial Number:	
Key Number:	

DECLARATION OF CONFORMITY

PL-OP-HM-TM-0105-R03

POLARIS		Polaris Sales Europe Sàrl Place de l'Industrie 2 1180 Rolle, Switzerland Telephone: +41 213-218-700
DECLARATION OF CONFORMITY		
March 1, 2021 Rolle, Switzerland		
Polaris Sales Europe Sàrl, declares that the vehicle(s) listed below conform to the essential requirements applicable to all terrain vehicles. This Declaration of Conformity is issued under the sole responsibility of the Manufacturer.		
CE		UK CA
APPLICABLE EUROPEAN DIRECTIVES 2006/42/EC as amended (Machinery Directive) 2014/30/EU as amended (EMC Directive)		APPLICABLE UK REGULATIONS Supply of Machinery (Safety) Regulations 2008 Electromagnetic Compatibility Regulations 2016
APPLICABLE HARMONISED STANDARDS EN ISO 12100:2010 Hazard Analysis EN 1690:2020/AC:2012 Driver Perceived Noise Level & Vibration UNECE R10		APPLICABLE UK DESIGNATED STANDARDS
MODEL	TRADE NAME	VEHICLE SERIAL NUMBER
RZZRRED4FA	RANGER DIESEL	-----
European Community Authorized Representative: Polaris Poland Sp. z o.o. ul. Włpólna 12, 45-037 Opole, Poland European Community Person Authorized to Compile the Technical File Lukasz Golak, Product Homologation Specialist Polaris Poland Sp. z o.o. ul. Włpólna 12, 45-037 Opole Poland		Authorized Manufacturer Signatory Empowered to Draw Up the EC Declaration of Conformity:  Rene Sasse Vice President EMEA

POLARIS		Polaris Sales Europe Sàrl Place de l'Industrie 2 1180 Rolle, Switzerland Telephone: +41 213-218-700
SUPPLEMENT TO THE OWNER'S MANUAL INFORMATION REGARDING EMISSION OF AIRBORNE NOISE AND VIBRATION PRODUCED BY THE MACHINERY AND CARBON DIOXIDE (CO₂) EMISSION		
A-Weighted Sound Pressure at Rider's Ear dB (A)	C-Weighted Sound Pressure Level dB (C)	A-Weighted Sound Power Level dB (A)
74	98	NA
Weighted Hand-Arm Vibration Level m/s ²		Weighted Seat Vibration Level m/s ²
1.3		0.1
Carbon Dioxide (CO₂) Emission g/kWh		
1047.4		
This CO ₂ measurement results from testing over a fixed test cycle under laboratory conditions a(n) (parent) engine representative of the engine type (engine family) and shall not imply or express any guarantee of the performance of a particular engine		

This document is setting out the contents of the EC Declaration of Conformity.
The particulars of machinery may differ for specific model.

INTRODUCTION

ORV CERTIFICATE OF PRE-DELIVERY INSPECTION

IMPORTANT

It is recommended that the owner of this vehicle receive a completed Certificate of Pre-Delivery Inspection form. If you did not receive this form (or a similar version to the sample below), consult your authorized dealer to obtain one.

ORV Certificate of Pre-Delivery Inspection			
RANGER - Mid-Size / Full Size (All except EV)			
Year: _____ Model: _____ Model #: _____			
VIN: _____ Engine Serial #: _____ Key #: _____ Mileage / Hours: _____			
Assembly / Service / Inspection <small>(Refer to Service Manual for Procedures and Specifications)</small>			
<input type="checkbox"/> SEALED BATTERY - Apply dielectric grease to terminal bolts and metal cables. Check charge and charge if below 12.8 DC Volts	<input type="checkbox"/> STEERING WHEEL - Torque fastener to specification	<input type="checkbox"/> CAB FRAME - Install and torque fasteners to specification	
<input type="checkbox"/> CONVENTIONAL BATTERY - Open Vent / Fill / Charge to 12.8 DC Volts / Install vent line / Install battery / Route vent line properly / Tight vent line if necessary	<input type="checkbox"/> FRONT GEARCASE - Add oil if needed	<input type="checkbox"/> SIDE SAFETY NETS - Install using the assembly instructions	
<input type="checkbox"/> BATTERY VOLTAGE - Measure and record battery voltage 30 minutes after charge has been removed. _____ DCV	<input type="checkbox"/> REAR GEARCASE (if applicable) - Add oil if needed	<input type="checkbox"/> SEAT BELTS - Install and check for smooth operation and latching	
<input type="checkbox"/> TIRE PRESSURE - Verify pressure is set to specification	<input type="checkbox"/> TRANSMISSION - Add oil if needed	<input type="checkbox"/> SEAT(S) - Inspect and install	
<input type="checkbox"/> WHEEL NUTS - Torque all to specification	<input type="checkbox"/> GREASE FITTINGS (if applicable) - Verify all suspension and prepart grease fitting locations are lubricated	<input type="checkbox"/> FUEL - Check level	
<input type="checkbox"/> REAR SHOCK POSITION (Full size CREW models only) - Move upper mount location to outer position and torque to specification	<input type="checkbox"/> ENGINE OIL - Add oil if needed - Dry Sump Engines - If engine oil is above full mark, refer to Service Manual for the "Oil System Priming Procedure"	<input type="checkbox"/> LIGHTS - Verify operation and adjustment	
<input type="checkbox"/> FRONT TOE ALIGNMENT - Verify proper toe setting	<input type="checkbox"/> ENGINE COOLANT - Inspect level in recovery bottle between MIN and MAX marks. Add coolant if needed	<input type="checkbox"/> WIRE HARNESS / HOSES / LINES - General inspection to ensure wires, hoses and lines are not kinked or pinched	
<input type="checkbox"/> BALL JOINTS - Inspect pinch bolts and/or cotter pins	<input type="checkbox"/> BRAKE FLUID - Inspect fluid level in brake master cylinder between MIN and MAX marks. Add brake fluid if needed	<input type="checkbox"/> UNIT INQUIRY - Complete Applicable Service Bulletins, Recalls and/or Factory Directed Modifications	
<input type="checkbox"/> TIE RODS - Inspect jam nuts and cotter pins	<input type="checkbox"/> PARK BRAKE (if applicable) - Verify proper operation and adjustment	<input type="checkbox"/> COSMETIC INSPECTION - Inspect vehicle for damage and proper fit and finish	
	<input type="checkbox"/> CARGO BOX - Verify operation		
	<input type="checkbox"/> THROTTLE / BRAKE CONTROLS - Verify correct and smooth operation		Assembled by (signature) _____ Date _____
Test Ride			
<input type="checkbox"/> ENGINE - Starting, acceleration and smoothness	<input type="checkbox"/> AWD - Verify proper operation	<input type="checkbox"/> LEAKAGE - Oil / Exhaust / Fuel / Coolant / Brake Fluid	
<input type="checkbox"/> BRAKES - Verify proper operation	<input type="checkbox"/> INSTRUMENTATION - Verify operational readings	<input type="checkbox"/> DIAGNOSTIC SYSTEM - Run engine up to full operating temperature. Use Digital Watch to generate and submit a "Service Report" (recommended process)	
<input type="checkbox"/> CLUTCH / TRANSMISSION - Verify proper shifting and transmission engagement / Indicator lights must correspond with gears	<input type="checkbox"/> SUSPENSION / STEERING - Verify adjustments, stability and operation	<input type="checkbox"/> CLEAN - Wash and clean vehicle for customer delivery	
<input type="checkbox"/> DRIVE/LINE - Verify smooth operation	<input type="checkbox"/> SOLE SPEED (Carbureted Models Only) - Verify and adjust if necessary as outlined in the Service Manual		Test Ridden by (signature) _____ Date _____
<input type="checkbox"/> ENGINE COOLANT - Inspect level in recovery bottle between MIN and MAX marks after test ride			
Delivery to Customer			
<input type="checkbox"/> WARRANTY REGISTRATION FORM - Complete	<input type="checkbox"/> BREAK-IN PROCEDURE - Review as outlined in Owner's Manual	<input type="checkbox"/> I certify that pre-delivery inspection and service have been performed on this vehicle in accordance with the instructions issued by Polaris.	
<input type="checkbox"/> OWNER'S MANUAL - Emphasize importance of reading for customer safety and servicing of vehicle / Explain periodic maintenance responsibilities	<input type="checkbox"/> CONTROLS - Show location and function		
<input type="checkbox"/> WARRANTY POLICY - Explanation / Limits / Requirements	<input type="checkbox"/> TOOL KIT - Show location	Dealering Name (print) _____	
<input type="checkbox"/> EMISSION SYSTEM WARRANTY POLICY - Explanation / Limits	<input type="checkbox"/> STORAGE / FUELING / TRANSPORTATION - Review as outlined in Owner's Manual	Dealer # _____	
<input type="checkbox"/> KEYS - Record number on key	<input type="checkbox"/> SAFETY FEATURES - Review all safety features of vehicle operation for new operator	Selling Dealer (signature) _____	Date _____
<input type="checkbox"/> BELT LIFE - Discuss proper operating procedures and proper use of high and low range (if applicable)	<input type="checkbox"/> DRIVING PROCEDURES - Review Operator Driving Procedures outlined in the Owner's Manual		
Customer Acceptance			
<input type="checkbox"/> I have reviewed and understand the Polaris warranty policy(ies).	PLEASE READ THE FOLLOWING DISCLAIMER AND "X" IF APPLICABLE		
<input type="checkbox"/> I have inspected the vehicle and I'm satisfied with my satisfaction.	<input type="checkbox"/> I have chosen not to purchase an Extended Service Contract at this time. I understand that by declining the POLARIS AR Protection Plan, I acknowledge that I have been offered the optional service plan for an amount in addition to the price of the vehicle itself that I have read the service plan and have decided not to buy it, and that I understand that I am not entitled to any benefits under this service plan.		
<input type="checkbox"/> I understand the importance of following the owner's manual instructions.	Customer Name _____		
<input type="checkbox"/> I understand the importance of using all safety features	Customer Signature _____		
<input type="checkbox"/> I understand the importance of all operators following the operator driving procedures in the owner's manual.	Date _____		
<input type="checkbox"/> My dealer has discussed the optional Extended Service Contracts available.			
WHITE / Dealer	CANARY / Customer	PN 9910088 R07 4/24/12 Printed in the USA	

NEAR-FIELD COMMUNICATION (NFC) (IF EQUIPPED)

Some Polaris vehicles come equipped with a near-field communication (NFC) chip. The NFC chip is embedded in the Polaris emblem located at the front of the vehicle and seamlessly connects you to a digital platform of vehicle information and tools. See your dealer for more information.

IMPORTANT

Not all devices are equipped with an NFC reader. Additionally, some devices require third party applications to access NFC content. For questions regarding the NFC reader on your device, refer to the device's user manual.

On models equipped with NFC, place your smartphone directly over the Polaris emblem to do the following:

- View vehicle specific information
- Access your Polaris Garage
- Download and view the owner's manual
- View accessory instructions
- Watch helpful videos
- Access warranty information
- Check for service notifications



RIDE COMMAND WITH NFC

Additional NFC features are available when using the Ride Command mobile app. To access these features, do the following:

1. Download the Ride Command mobile app from the Apple App Store® or Google Play® store.
2. Create or log in to an existing account.
3. From the Ride Command mobile app home screen, select **Add Vehicle**.
4. On the vehicle, tap the NFC-enabled badge with the phone to scan the vehicle.
5. Confirm information, name your vehicle, and tap add to garage.

SYSTEM REQUIREMENTS

Refer to device manufacturer's instructions to verify NFC read capability, and/or NFC-capable add-ons.

IMPORTANT ISRAEL MODEL INFORMATION

ISRAEL MODEL DIFFERENCES

IMPORTANT

Israel models are significantly different from other models covered by this owner's manual. The unique characteristics of Israel models will not be referenced throughout the rest of this owner's manual. If you are using an Israel model, carefully read the statements below and bear them in mind before consulting the rest of the owner's manual.

ISRAEL MODELS ARE TWO-PERSON VEHICLES.

Israel models are designed to accommodate two individuals - a driver and a passenger. Do not operate Israel models with more than one passenger, as only two seat belts are available for use. If you are using an Israel model, disregard all other mentions of "passengers" within the manual text.

DECLARATION OF CONFORMITY NOTE

The "Declaration of Conformity" section (in the Introduction chapter) does not apply to Israel models. Disregard the "Declaration of Conformity" section if you are using an Israel model.

ISRAEL MODELS ARE ON-ROAD VEHICLES.

Israel models are certified for on-road use in your region. Disregard warnings prohibiting on-road use in the manual text if you are using an Israel model.

IMPORTANT ISRAEL MODEL INFORMATION

GENERAL ALERT

The General Alert is located on the console.



WARNING

Read the owner's manual. Never allow anyone under 16 years of age to operate this vehicle. Never use alcohol or drugs before or while driving or riding. This vehicle is approved for on-road operation. Wear approved helmet, goggles, and protective clothing. Always wear seat belts. Always use the cab nets or doors. Avoid aggressive driving maneuvers that may cause vehicle tipping or rollover.

CLUTCH COVER ALERT

The Clutch Cover Alert decal is located on the clutch cover.

CAUTION

Read your owner's manual. Keep body parts away from belt.



FUEL INFORMATION

Read owner's manual. Use only compatible diesel fuels in this vehicle. Compatible fuels: B7, B10, B20.

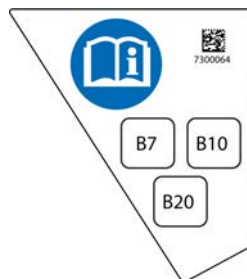

INTAKE ALERT

The Intake Alert Caution label is located on the air intake.

⚠ CAUTION

Use a Polaris approved air filter. The use of a non-Polaris approved air filter may cause engine damage. Before installing filter ensure there is no dirt or debris in the clean side of the intake tube. The air filter must be properly seated and the hinges fully inserted when the lid is reinstalled. Please reference your owner's manual for additional information regarding the air filter service.



HITCH CAPACITY ALERT

The Hitch Capacity Alert is located on the hitch receiver.

⚠ WARNING

Read the owner's manual.

MAXIMUM DRAWBAR PULL: 3200 N
ON LEVEL GROUND

MAXIMUM VERTICAL LOAD: 1700 N

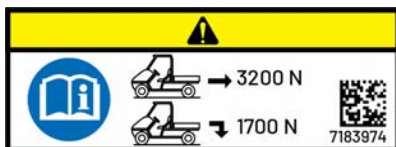

IMPORTANT ISRAEL MODEL INFORMATION

LOAD / PASSENGER / TIRE PRESSURE ALERT



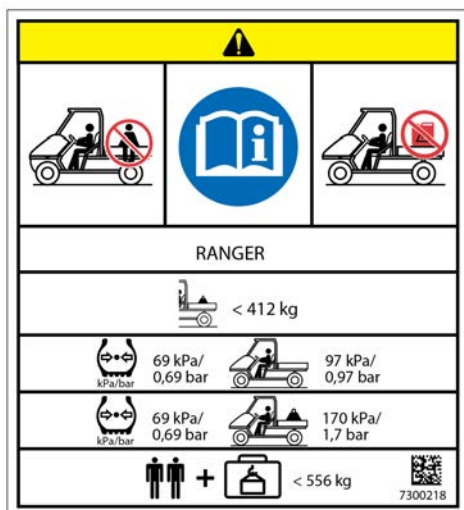

WARNING



Never carry passengers in cargo box. Passengers can be thrown off. This can cause serious injury or death. Read owner's manual. Never carry or transport fuel on this vehicle.



RANGER

 $< 412 \text{ kg}$

 69 kPa/ 0,69 bar	 97 kPa/ 0,97 bar
 69 kPa/ 0,69 bar	 170 kPa/ 1,7 bar

 +  $< 556 \text{ kg}$ 7300218

VEHICLE	MAXIMUM CARGO BOX LOAD	TIRE PRESSURE IN KPA/BAR	MAXIMUM CAPACITY
RANGER	412 kg	Front: 69 kPa/0,69 bar Rear: 97 kPa/0,97 bar Pressures at MAX Cargo Box Load Front: 69 kPa/0,69 bar Rear: 170 kPa/1,70 bar	Occupants: 2 Weight (Driver + Passengers + Tow Load): 556 kg

SAFETY

OWNER REQUIREMENTS

Improper use, maintenance, or modification of this vehicle can lead to serious injury or death.

Require proper use of your vehicle. Do not allow anyone to operate your vehicle or ride as a passenger unless they are properly instructed and you are sure they are willing to ride responsibly. To prevent unauthorized use, always remove the ignition key when the vehicle is not in use.



Any modifications or installation of non-POLARIS-approved accessories could increase the risk of injury. While you may find aftermarket products similar in design and quality to POLARIS accessories, recognize that some aftermarket accessories or modifications are not suitable because of potential safety hazards to you or others. It is never appropriate to install any additional seating.

Check with the manufacturer to determine any potential effect of a modification or accessory on the safe use of your vehicle. You are responsible for injuries related to modifications to the vehicle. Modifications or accessories may:

- Damage machine components - especially modifications that increase speed or power.
- Make the vehicle less stable at higher speeds.
- Add weight, reducing the amount of cargo and total weight you can carry, and raise the vehicle's center of gravity.
- Overload the vehicle's electrical system capacity. Blowing a fuse may cause a loss of lights or engine power.
- Reduce the effectiveness of occupant protection systems, including the seatbelts and the Rollover Protective Structure (ROPS).
- Make it illegal to own or operate your vehicle. POLARIS-authorized spark arresters, mufflers, and emissions control components are mandatory for ownership or operation in many areas.
- Void your warranty.

The vehicle ROPS, when used with the seat belts and doors, provides a structure to help protect occupants. The structure will not protect occupants in all rollovers or accidents.

For more information about safety, contact an authorized dealer or visit the Polaris website at www.polaris.com.

DRIVER AND PASSENGER QUALIFICATIONS

Make sure operators are 16 or older with a valid driver's license. Just because a teenager has a license does not mean that they will make good judgments about driving and avoid risk taking.



POLARIS recommends that you supervise younger drivers. Set rules and put limits on how, when, and where they are allowed to use this vehicle. For example, young drivers may need to have an adult in the vehicle with them and not be allowed to drive with their friends in the vehicle.

Make sure all riders fit the vehicle. Be sure that the driver and all passengers are able to:

- sit with their backs against their seat,
- adjust the seat belt to fit properly,
- have both feet flat on the floor, and
- have both hands on the steering wheel or on a passenger hand hold.

Do not allow children who need child safety seats or booster seats to ride in the vehicle. The vehicle is not designed to restrain automotive child safety seats.

You are responsible for your passengers. Be sure passengers are seated properly, belted, holding the passenger hand hold, and ready to brace. Unrestrained riders can fall out or be thrown around and from a moving vehicle.

Every person must be properly seated and belted in their own seat. Two people should never be belted into a single seat belt. People belted together can crash into one another in a collision and be seriously injured. Never carry passengers in the cargo bed as they could be thrown against or out of the vehicle or come into contact with moving parts.

Do not let people drive or ride after using alcohol or drugs.

PREPARE VEHICLE FOR THE RIDE

Before starting off, always perform the Pre-Ride Inspection. Failure to inspect and verify that the vehicle is in safe operating condition increases the risk of an accident, which can lead to serious injury or death.



ITEM	REMARK	REFERENCE
Brake Fluid	Ensure proper level and condition	page 137
Front and rear suspension	Inspect	—
Steering	Ensure free operation	page 139
Tires	Inspect condition and pressure	page 141
Wheels/Lug Nuts	Inspect, ensure fastener tightness	page 141
Fuel and oil	Ensure proper levels and condition	page 89 page 104
Coolant	Ensure proper level and condition	page 114
Indicator lights/switches	Ensure proper operation	page 46 page 64
Air Filter	Inspect, replace as needed	page 125
Engine intake pre-filter	Inspect, clean	page 128
PVT intake pre-filter	Inspect, clean	page 128
Headlights	Check operation	page 146
Brake lights/taillights	Check operation	page 148
Seat Belts	Check length of belt for damage, check latches for proper operation	page 53

SAFETY

ITEM	REMARK	REFERENCE
Exhaust	Inspect spark arrester and clean if needed.	page 127
Vehicle Debris	Remove grass, leaves, and other flammable material or debris, especially near the exhaust system.	-
Lock adjustable steering wheel	Do not adjust the steering wheel while the vehicle is moving.	page 44
Alternator Belt (if equipped)	Inspect for cracks, damage. Replace, if necessary.	-

Improper tire maintenance can lead to loss of control and an accident, which could result in serious injury or death. To reduce your risk of injury:

- Maintain POLARIS recommended tire pressure. Check pressure before operating. Even if your vehicle has only been driven a short distance, the tire pressure readings can become higher.
- Make sure tire pressures match the specifications listed in the table below.
- Only use the size and type of tires specified for this vehicle.
- Do not operate your vehicle with worn or damaged tires.
- Always follow your tire manufacturer's instructions for maintenance.

MEASUREMENT	SPECIFICATION	
	MD / ZUGMASCHINE	TRACTOR
Maximum Cargo Box Load	412 kg	
Tire Pressure in kPa (bar)	FRONT: 69 (0,69) REAR: 97 (0,97)	
Tire Pressure with Full Load (MAX CARGO + PASSENGER) in kPa (bar)	FRONT 69 (0,69) REAR 210 (2,1)	FRONT 69 (0,69) REAR 170 (1,7)
Maximum Weight Capacity Includes weight of operator, passenger, cargo, and accessories	696 kg	556 kg

PREPARE YOURSELF, PASSENGERS, AND CARGO FOR THE RIDE

Wear an approved helmet. Riding in this vehicle without wearing an approved helmet increases the risk of serious injury. For example, a helmet reduces your risk of injury from head strikes with the vehicle or other objects even if there is no crash.

Approved helmets in the USA and Canada bear a U.S. Department of Transportation (DOT) label. Approved helmets in Europe, Asia, and Oceania bear the ECE 22.05 label. The ECE mark consists of a circle surrounding the letter E, followed by the distinguishing number of the country which has granted approval. The approval number and serial number will also be displayed on the label.



Use shatterproof goggles or a shatterproof helmet face shield. Such protective eyewear may reduce the risk of foreign material getting in your eyes and help prevent loss of vision.

POLARIS recommends wearing approved Personal Protective Equipment (PPE) that have markings indicating they are designed to standards such as:

- VESC 8
- V-8
- Z87.1
- CE



Additional protective clothing and gear that may be appropriate for your riding conditions includes:

- Always wear shoes when operating. Consider wearing sturdy over-the-ankle boots suitable for the terrain you will be riding in.
- Full-finger gloves can protect against wind, sun, cold, and objects. Choose gloves that fit snugly and allow fingers to move freely and grip on the steering wheel or hand holds.
- Consider long sleeves and long pants to help protect arms and legs.
- Long-term exposure to wind and engine noise can cause permanent hearing loss. Properly worn hearing protective devices such as earplugs can help prevent hearing loss. Check local laws or the rules of the riding area you are in before wearing hearing protection to make sure its use is permitted.

Always stay completely inside the vehicle and hold the steering wheel or hand holds. Body parts outside of the vehicle can be struck by passing objects or crushed during a rollover. Do not put any part of your body outside of the vehicle for any reason. Do not hold onto the ROPS frame or put any part of your body on the door.

Riding in this vehicle without closed and latched cab doors increases the risk of serious injury or death in the event of an accident or rollover. Always make sure all cab doors are closed and latched while riding in this vehicle.

Be sure riders pay attention and plan ahead. If you think or feel the vehicle may tip or roll, reduce your risk of injury:

- Keep a firm grip on the steering wheel or hand holds and brace yourself.
- Do not put any part of your body outside of the vehicle for any reason.

This vehicle is not designed to carry unrestrained pets. An unrestrained pet can be thrown about and injure riders, even during normal operation. When transporting pets, use a pet crate suitable for off-road use that is secured to the vehicle.

Fuels such as gasoline can be extremely flammable. To reduce the risk of serious injury or death, never carry fuel or other flammable liquids on this vehicle. Rollovers, crashes, rough riding, or changes in elevation or temperature may lead to fuel spilling or vapor release from portable containers. Hot vehicle parts can cause fires, even after the engine has been turned off.

Never exceed vehicle weight capacities. The vehicle's maximum weight capacity (including riders, cargo, and accessories) is 740 lbs. (336 kg) total. The cargo box can support up to 600 bs. (272 kg) of that total. When more rider weight is added, cargo weight may need to be eliminated to stay under the 740 lb. (336 kg) limit. Overloading the vehicle or carrying cargo improperly will cause changes in stability and handling, which could cause loss of control or an accident.

Secure cargo in the cargo box as far forward, centered and as low as possible. When cargo cannot be positioned and secured in this way, operate with extra caution. Unsecured cargo can strike and injure riders, affect vehicle handling, and result in loss of control.

The weight of riders and cargo changes vehicle braking, handling, and stability. To avoid loss of control, turn gradually, operate at slower speeds, and avoid rougher or steeper terrain.

DRIVING GUIDELINES

Drive responsibly. This vehicle is not a toy and can be hazardous to operate.

This vehicle has higher ground clearance and other features to handle rugged terrain. It can be overturned in situations where some other vehicles may not. Abrupt maneuvers or aggressive driving, even on flat, open areas, can cause loss of control, rollovers, severe injury or death. To avoid loss of control and rollovers:



- Avoid abrupt maneuvers, sideways sliding, skidding, or fishtailing, and never do donuts.
- Slow down before entering turn.
- Avoid hard acceleration when turning, even from a stop.

High speed off-road operation

Driving off-road vehicles to test the limits of your skills or abilities can be very dangerous to you, passengers, and bystanders. Basic skills for driving a car, ATV, or other off-road vehicles do not equip drivers to safely attempt high speed off-road operation. Develop your skill gradually through training, practice, and experience with the various driving modes of this vehicle and the terrain in which you are operating. Always do a low speed reconnaissance run (prerun) to become aware of anything you may encounter.

High speed off-road operation can lead to loss of control, crashes, or hard landings that can seriously injure occupants (even without rolling the vehicle or damaging it).

If you plan on using the vehicle for high speed, off-road competition, additional safety equipment may be necessary. Check the rules that apply to your competition.

Do not go over jumps — going airborne can lead to serious injury or death.

Going airborne can cause loss of control, rollovers, or crashing into the ground and may damage the vehicle. Even without crashing, landings can be hard enough to cause any vehicle suspension to fully compress (e.g., bottom out). Serious injuries, including spinal injuries, can occur even if riders are properly harnessed, wearing helmets and the vehicle is not damaged and remains upright.

You may encounter slopes, "jumps", or other terrain features that could send the vehicle airborne, depending on your speed. These may be defectively designed, poorly maintained, or not suitable for this vehicle. Slow down, use extra care, and avoid going airborne. Never take this vehicle over jumps.

Watching someone else go over a jump or go airborne does not mean you can safely do so. Polaris cannot determine whether any jump you may encounter is appropriate for this vehicle. Any jump, even a small one, could be poorly maintained, designed, or not suitable for this vehicle and may cause serious injury or death.



Plan for hills, rough terrain, ruts, and other changes in traction and terrain.

Proceed slowly and with extra care on unfamiliar terrain. Avoid paved surfaces. Sudden changes in terrain such as holes, depressions, banks, softer or harder ground, or other irregularities may cause loss of control or rollover. Give yourself time to react to rocks, bumps, or holes that may be hard to see. Operating in deep snow or tall grass may make it harder to see obstacles.

If you cannot go around an obstacle, such as a fallen tree or a ditch, stop the vehicle in a safe place. Get out to inspect the area thoroughly. Look from both your approach side and exit side. If you are reasonably confident you can continue safely, choose the path that will allow you to go straight over the obstacle to minimize the vehicle tipping sideways. Go only fast enough to maintain your momentum, but still give yourself plenty of time to react to changes in conditions. If there is any question about your ability to maneuver safely over the obstacle, you should turn around if the ground is flat and you have the room, or back up until you find a less difficult path.

Abrupt application of the accelerator pedal can cause the tires to lose traction, reducing control of the vehicle and increasing the possibility of an accident, especially while on sloped terrain or while crossing obstacles such as rocks or logs.

SAFETY

MD MODELS ONLY

Avoid Operating on Public Roads (Paved or Otherwise). This vehicle does not have highway safety features that on-road vehicles may have (air bags, anti-lock brakes, stability control, etc.). If another vehicle collides with you, the likelihood of a serious injury or death may be greater. Also, you may not be able to avoid a crash or rollover if you make sudden or abrupt maneuvers such as swerving or emergency braking. While it may be legal locally to drive on some public roads in specific parts of the country, your vehicle was not designed or certified as an on-road motor vehicle. Polaris does not support public road use except as may be necessary to cross-roads designated for connecting off highway vehicle trail segments. If you must drive on-road, drive slowly and defensively. Your vehicle may lack the features needed to comply with state or local laws that permit limited public road use. Modifications you make to your vehicle to meet these requirements may void the vehicle warranty. In addition, refer to tire manufacturer's instructions or limitations for on-road operation, including speed limits and premature tire wear.

ZUGMASCHINE OR TRACTOR MODELS ONLY

This vehicle is approved for on-road use.

Improperly operating on hills can cause loss of control, rollover, or accident, which can lead to serious injury or death. Use extra care when operating on hills. Plan for rough terrain, ruts, and other changes in traction and terrain.

Driving up hills

Check the terrain before ascending a hill and make sure it is not too slippery or loose. Engage all-wheel drive for hills. Drive straight uphill, keeping speed and throttle steady. Avoid steep hills which can cause the vehicle to overturn.

Recovering from stalling on a hill

If the vehicle loses forward speed, apply the brakes gradually and stop. Do not attempt to turn the vehicle around. Instead, shift to reverse and allow the vehicle to slowly roll straight downhill. Apply light brake pressure to control speed.

Overtopping a hill

Slow down when you reach the crest of a hill. Never blindly go over the crest of a hill or a drop off at high speed. An obstacle, a sharp drop, or another vehicle or person could be on the other side of the hill.

Driving down hills

Check the terrain before descending a hill and make sure it is not too slippery or loose. Engage all-wheel drive and proceed slowly, applying the brakes lightly. Never descend a hill with the transmission in neutral or if the engine is turned off.

Avoid side hilling (riding across slopes)

If unavoidable, proceed slowly and with extra caution. Avoid obstacles and changes in terrain that could cause the vehicle to tip or slide. If it feels like the vehicle begins to tip or slide, immediately turn downhill.

Riding near wooded areas or brush

Use extra caution when operating near trees, particularly when operating on narrow trails. Tree branches or brush can be driven into the cab striking or stabbing occupants.

**Riding in snow**

Always keep the brake and accelerator pedals free of snow and ice. Apply the brakes frequently to prevent ice or snow accumulation on the brake pads which can reduce brake performance.

Riding on ice

Never operate the vehicle on a frozen body of water unless you have verified that the ice can support the weight of the vehicle. Severe injury or death can result if the vehicle falls through the ice.

Riding in water / Falling into water

Operating through deep or fast-flowing water can cause loss of traction, loss of control, overturning, or being swept away in water. You can be seriously injured or killed from entrapment and drowning. Never operate the vehicle in fast-flowing water or in water that exceeds the floor level of the vehicle. Avoid sharp drop-offs and large rocks. Choose a path that provides an entrance and exit point with gradual inclines. Wet brakes may have reduced stopping ability. After leaving water, test the brakes. Apply them lightly several times while driving slowly. The friction will help dry out the pads.

Riding on sand dunes

Use extra caution when operating on or near dunes. Be alert for changes in terrain. Never blindly go over the crest of a hill or a drop-off at high speed. An obstacle, a sharp drop, or another vehicle or a person could be on the other side of the hill.

Riding in low-visibility conditions

Use extra caution and drive slowly in conditions of reduced visibility such as fog, rain, and darkness.

Plan ahead to avoid the need for evasive maneuvers, such as swerving.

Hitting an obstacle — including wildlife — you are not ready for can be dangerous. Choosing to swerve instead can be even more dangerous because it can lead to loss of control, rollover, or collisions.

When operating in areas with possibility of wildlife appearing in your path, plan ahead to avoid swerving for animals if doing so could result in collisions or rollovers. Go slowly or avoid driving during seasons or times of day when animals such as deer are more likely to cross your path without warning.

SAFETY

Avoid Collisions With Other Vehicles

When following another vehicle or operating in the same area as others, keep a safe distance to avoid collisions. Allow extra space when sight distances are limited by dust, snow, curves, hills, or other conditions. Plan ahead to avoid having to swerve or leave the trail to avoid a collision.

On trails, be prepared to make space for other vehicles to pass. If you need to stop on a trail, move your vehicle to the edge of the path to allow others to pass safely.

Correct a skid by turning the steering wheel in the direction of the skid.

Never apply the brakes during a skid.

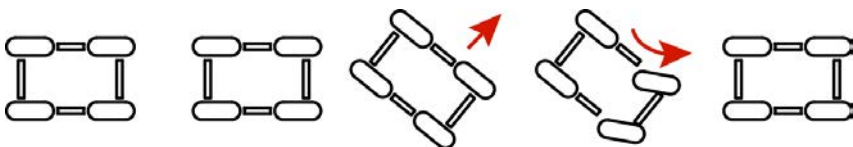

If the vehicle begins to slide downhill or you feel it may tip, turn downhill immediately and stop. Maneuver slowly and carefully until you can drive straight downhill.

Do not continue driving if your vehicle may be damaged or if you were in a crash or rollover.

Operating the vehicle while damaged or after a crash or rollover can cause loss of control, rollover, or accident, which can lead to serious injury or death. If you cannot safely transport the vehicle on your own, contact a recovery and towing service.

After any crash, rollover, or other accident, have a POLARIS dealer inspect the vehicle for possible damage, including seat belts, ROPS, brakes, suspension, and steering systems.

Be prepared in case your vehicle becomes damaged or disabled, especially in remote areas. Consider in advance how to get help and stay safe until it arrives whenever you ride.

There is a recovery tow loop at the front and back of the vehicle to attach a winch or strap.

Use these loops to recover this vehicle if it is stuck, to pull it onto a tow truck, trailer, or to use this vehicle to recover another vehicle. These loops are for emergency recovery only and are not for towing vehicles to another location.

Improper recovery may lead to loss of control or vehicle damage. Only attach straps to specified locations. Do not attach to any other point on the vehicle. Only recover a vehicle of equal or lesser size and weight. When recovering a disabled vehicle, place the disabled vehicle's transmission in neutral. Do not move a disabled vehicle faster than 16 km/h.

Operating, Idling, Or Parking Near Combustible Materials

Engine, exhaust, and other vehicle components can be very hot during and after use. Do not idle or park the vehicle over anything that could contact the exhaust system and catch on fire, such as tall grass, weeds, brush, leaves, debris, or other tall ground cover. Do not let mud, grass, or other debris accumulate on the engine or exhaust system. Inspect and remove as needed.

Vehicle rollaway can cause serious injury or death. This vehicle can roll whenever the gear selector is not in the PARK (P) position. Always shift to PARK (P) when stopping the engine or leaving the vehicle. When leaving the vehicle on an incline is unavoidable, use extra care. If leaving the vehicle unattended, block the rear wheels on the downhill side and keep children, pets, and others away from the gear selector.

Before shifting into reverse, use extra care to make sure the area is clear of people or obstacles. When it's safe to proceed, back slowly.

After operation, inspect the vehicle for damage and debris to make sure the vehicle can be safely stored and operated again. Some things to inspect include:

- Debris that could catch fire, such as mud/grass near the engine or exhaust system
- Damage to the suspension, steering, or any other part of the vehicle
- Tire condition, such as tread and sidewall damage
- Shock absorber assembly condition

Be sure to have any issues checked and problems fixed before operating again.

All engine exhaust contains carbon monoxide, a deadly gas. Breathing carbon monoxide can cause headaches, dizziness, drowsiness, nausea, confusion, and eventually death. Carbon monoxide is a colorless, odorless, tasteless gas which may be present even if you do not see or smell any engine exhaust. Deadly levels of carbon monoxide can collect rapidly, and you can quickly be overcome and unable to save yourself. Also, deadly levels of carbon monoxide can linger for hours or days in enclosed or poorly ventilated areas. If you experience any symptoms of carbon monoxide poisoning, leave the area immediately, get fresh air, and **SEEK MEDICAL TREATMENT**.

- Do not run engine indoors. Even if you try to ventilate engine exhaust with fans or open windows and doors, carbon monoxide can rapidly reach dangerous levels.
- Do not run engine in poorly ventilated or partially enclosed areas such as barns, garages, or carports. If you start a vehicle in one of these, drive it out and close the door as soon as possible. If you drive it into one of these, turn it off as soon as possible.
- Do not run engine outdoors where engine exhaust can be drawn into a building through openings such as windows and doors.

The above list of hazards and overturning risk is not exhaustive.

SAFETY

TRANSPORTING THE VEHICLE

Follow these procedures when transporting the vehicle.

1. Apply the brakes.
2. Place the transmission in PARK. Stop the engine.
3. Slowly release the brake pedal and make sure the transmission is in PARK before exiting the vehicle.
4. Remove the key to prevent loss during transporting.
5. Secure the fuel cap and seat. Ensure that the seat is attached correctly and is not loose.

WARNING

Cargo and other loose vehicle parts may fly off while transporting this vehicle. Secure or remove all cargo, and inspect the unit for loose parts prior to transport.

If transporting the vehicle in a non-enclosed trailer, then the vehicle must FACE FORWARD, or roof must be removed.

Failure to comply may allow airflow, vibration, or other factors to separate the roof from the vehicle and cause an accident, resulting in serious personal injury or death.

6. Using suitable straps or rope, always secure the vehicle to the trailer using the designated tie down points (front and rear).

① Front tie-down points

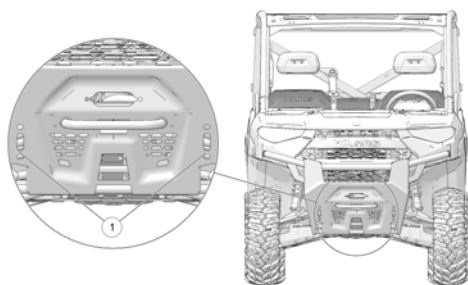

② Rear tie-down points

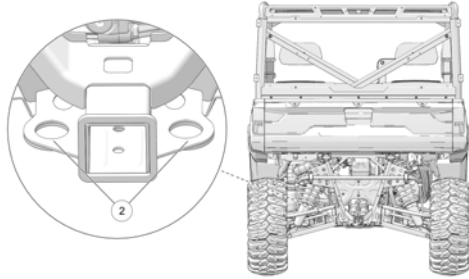

TOWING A RANGER

Towing this vehicle is not recommended. Always transport the vehicle on a trailer or flatbed with all four wheels off the ground.

If towing a disabled vehicle is unavoidable, place the disabled vehicle's transmission in neutral. Tow the shortest distance possible. Do not operate faster than 16 km/h (10 MPH).

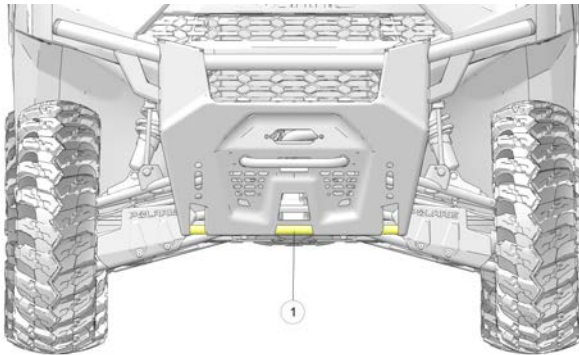

1. Towing Point

LIGHTNING AND POWERLINES

Avoid operating this vehicle when lightning could occur and when near powerlines. Rubber tires, rubber handgrips, and a foam seat will not protect a rider from lightning strikes or electrical surges. Always seek safe shelter when lightning is imminent, and keep a safe distance from powerlines at all times.

FORESTRY APPLICATION AND CROP SPRAYING

This vehicle does not have a Falling Objects Protective Structure (FOPS). Do not use the vehicle in forestry application situations where the risk of falling objects may be present.

This vehicle is not equipped for protection against hazardous substances. It does not offer any protection against substances which are harmful to health. Always wear proper personal protective equipment if this vehicle is used for crop spraying or other applications requiring the use of hazardous substances.

HOT EXHAUST SYSTEMS

WARNING

Exhaust system components are very hot during and after use of the vehicle. Hot components can cause burns and fire. Do not touch hot exhaust system components. Always keep combustible materials away from the exhaust system.

Use caution when traveling through tall grass, especially dry grass and when traveling through muddy conditions. Always inspect the underside of the vehicle and areas near the exhaust system after driving through tall grass, weeds, brush, other tall ground cover, and muddy conditions. Promptly remove any grass, debris or foreign matter clinging to the vehicle and pay particular attention to the exhaust system area.



MD MODELS ONLY**GENERAL ALERT**

The General Alert decal is location on the cargo box.

**⚠ WARNING**

Read your owner's manual. Never allow anyone under 16 years of age to operate this vehicle. Never use alcohol or drugs before or while driving or riding. Do not allow operation on public roads (unless designated for off-highway vehicle access). Wear approved helmet, goggles, and protective clothing. Always wear seat belts. Always use the cab nets or doors. Never exceed seating capacity.

Part number: 7187455

HITCH CAPACITY ALERT

The Hitch Capacity Alert is located on the hitch receiver.

⚠ WARNING

Read the owner's manual.
 MAXIMUM DRAWBAR PULL: 3200 N
 ON LEVEL GROUND
 MAXIMUM VERTICAL LOAD: 1700 N

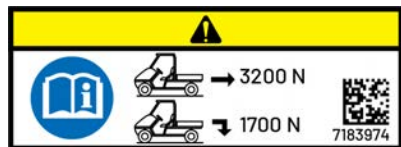

Part number: 7183974

HOT LIQUID WARNING

The Hot Liquid Warning label is located on the radiator.

⚠ WARNING

Hot liquids and steam may cause severe injury or burns. Allow the vehicle to cool before attempting to remove the radiator cap.



Part number: 7300427

SAFETY

TRACTOR MODELS ONLY

GENERAL ALERT

The General Alert is located on the console.



⚠ WARNING

Read the owner's manual. Never allow anyone under 16 years of age to operate this vehicle. Never use alcohol or drugs before or while driving or riding. This vehicle is approved for on-road operation. Wear approved helmet, goggles, and protective clothing. Always wear seat belts. Always use the cab nets or doors. Avoid aggressive driving maneuvers that may cause vehicle tipping or rollover.

Part number: 7300632

JACKING POINTS ALERT

The Jacking Point Alert decal is located in the cargo box.

⚠ CAUTION

Jacking positions are located beneath the vehicle's center points.

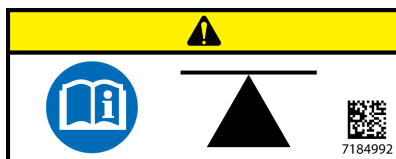

Part number: 7184992

GREASING POINTS ALERT

The Greasing Points Alert is located on the cargo box.

⚠ CAUTION

Lubricate as recommended. Read owner's manual.

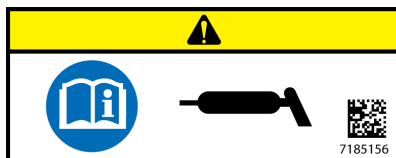

Part number: 7185156

HOT EXHAUST SYSTEM WARNING

WARNING

Exhaust system components are very hot during and after use of the vehicle. Hot components can cause burns and fire. Do not touch hot exhaust system components. Always keep combustible materials away from the exhaust system.

Use caution when traveling through tall grass, especially dry grass and when traveling through muddy conditions. Always inspect the underside of the vehicle and areas near the exhaust system after driving through tall grass, weeds, brush, other tall ground cover, and muddy conditions. Promptly remove any grass, debris or foreign matter clinging to the vehicle and pay particular attention to the exhaust system area.

Part number: 7185151



MD AND TRACTOR MODELS

CLUTCH COVER ALERT

The Clutch Cover Alert decal is located on the clutch cover

CAUTION

Read your owner's manual. Keep body parts away from belt.

Part number: 7181427



OWNER'S MANUAL ALERT

The Owner's Manual Alert is located on the console.

Read the owner's manual.

Part number: 7185807



FUEL ALERT

Read owner's manual. Use only compatible diesel fuels in this vehicle. Compatible fuels: B7, B10, B20.

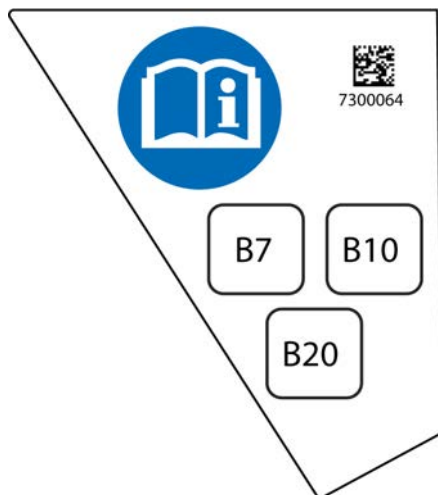

SHIFT ALERT

The Shift Alert is located on the console.

WARNING

To avoid transmission damage, shift only when vehicle is stationary and at idle.

APPLY BRAKE TO START.

When this vehicle is not in operation, or unattended, place shift in the park position.

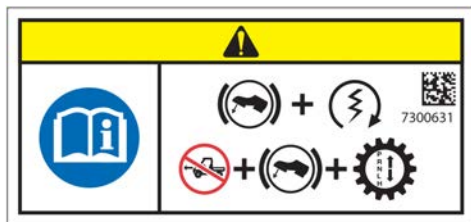

Part number: 7300631

SAFETY

















LOAD/PASSENGER/TIRE PRESSURE ALERT

The Load/Passenger/Tire Pressure Alert is located on the cargo box.

WARNING

Never carry passengers in cargo box. Passengers can be thrown off. This can cause serious injury or death. Read owner's manual. NEVER carry fuel or other flammable liquids on this vehicle. Failure to follow this instruction could lead to serious burn injuries or death.

Part number: 7300074

RANGER TR	
	
	
	
RANGER TR	
 < 412 kg	
 69 kPa/ 0,69 bar	 97 kPa/ 0,97 bar
 69 kPa/ 0,69 bar	 170 kPa/ 1,7 bar
 < 556 kg	
RANGER EU/ZUG	
 < 412 kg	
 69 kPa/ 0,69 bar	 97 kPa/ 0,97 bar
 69 kPa/ 0,69 bar	 210 kPa/ 2,1 bar
 < 696 kg	
 7300074	

RANGER Tractor	
MAXIMUM CARGO BOX LOAD	412 kg
TIRE PRESSURE IN kPa (bar)	FRONT 69 (0,69) REAR 97 (0,97)
TIRE PRESSURE WITH FULL LOAD (MAX CARGO + PASSENGER) IN kPa (bar)	FRONT 69 (0,69) REAR 170 (1,7)

MAXIMUM WEIGHT CAPACITY INCLUDES WEIGHT OF OPERATOR, PASSENGER, CARGO AND ACCESSORIES	556 kg
Read Operation and Maintenance Manual for more detailed loading information.	

FEATURES AND CONTROLS

COMPONENT LOCATIONS

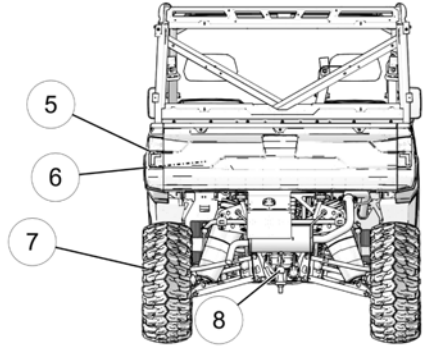
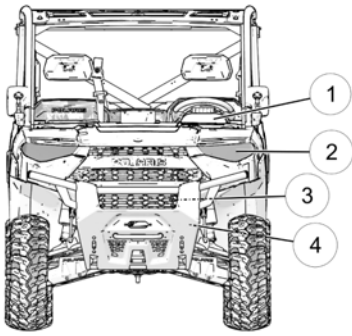

- ① Console
- ② Headlights
- ③ Radiator
- ④ Bumper / Brush Guard

- ⑤ Taillights
- ⑥ Tailgate
- ⑦ CV Boot / Rear Caliper
- ⑧ Receiver Hitch

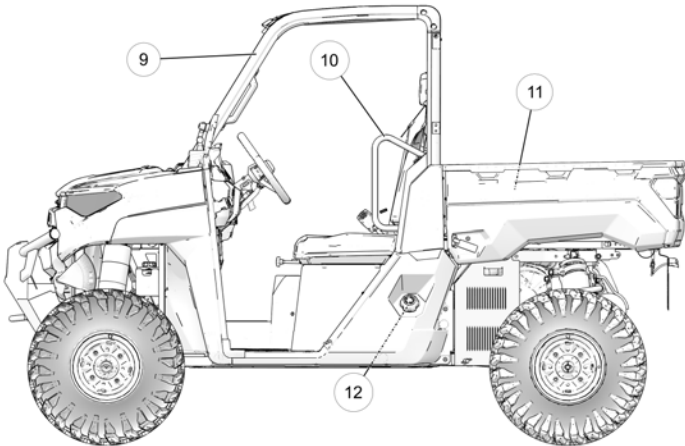

- ⑨ ROPS Cab Frame
- ⑩ Hip Bar

- ⑪ Cargo Box
- ⑫ Fuel Cap

FEATURES AND CONTROLS

CONSOLE

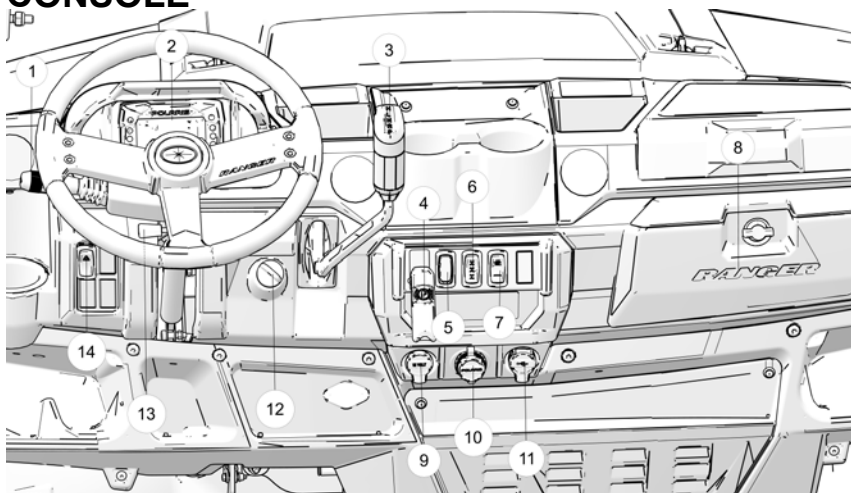

- | | |
|----------------------------------|-----------------------------|
| ① Turn Signal Lever | ⑧ Storage Compartment |
| ② Instrument Cluster | ⑨ 12V Auxiliary Outlet |
| ③ Gear Selector (Shifter) | ⑩ Charge Port |
| ④ Park Brake Lever | ⑪ 12V Auxiliary Outlet |
| ⑤ Glow Plug/Park Brake Indicator | ⑫ Ignition Switch |
| ⑥ AWD Switch | ⑬ Steering Adjustment Lever |
| ⑦ ADC Switch | ⑭ Hazard Switch |

ADJUSTABLE STEERING WHEEL

The steering wheel can be tilted upward or downward for rider preference. Lift and hold the adjustment lever ① toward you while moving the steering wheel upward or downward. Release the lever when the steering wheel is at the desired position. Always make sure the steering wheel position does not impede proper operation of the brake pedal, throttle pedal, and all other controls.

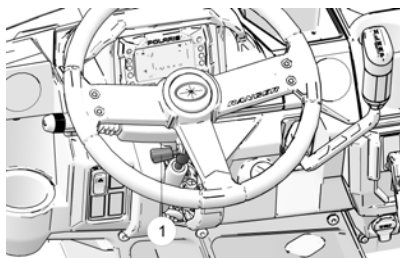

GEAR SELECTOR

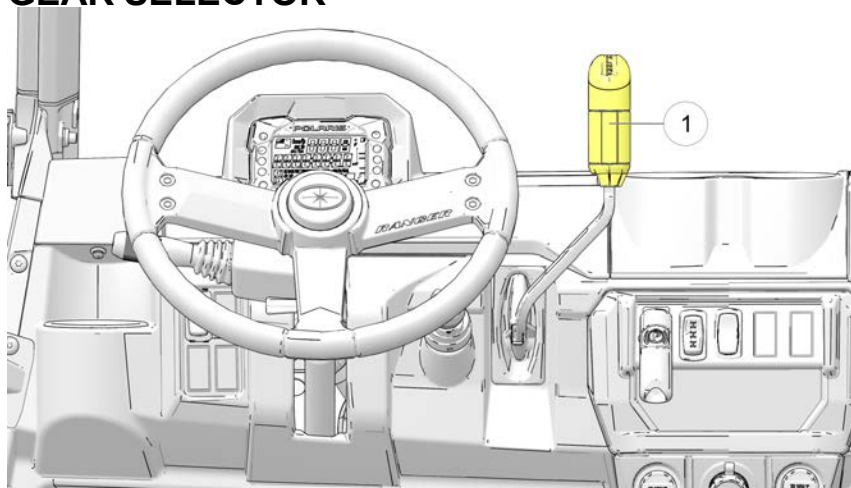

To change gears, stop the vehicle, and with the engine idling, move the lever ① to the desired gear. Do not attempt to shift gears with engine speed above idle or while the vehicle is moving.

- H: High Gear
- L: Low Gear
- N: Neutral
- R: Reverse
- P: Park

Low gear is the primary driving range for the RANGER. High gear is intended for use on hard-packed surfaces with light loads. Whenever the vehicle is left unattended, always place the transmission in PARK.

TIP

Maintaining shift linkage adjustment is important to assure proper transmission function. Your POLARIS dealer can assist in resolving any shifting problems.

NOTICE

Do not attempt to shift the transmission while the vehicle is moving or damage to the transmission could result. Always shift when the vehicle is stationary and the engine is at idle.

FEATURES AND CONTROLS

USING LOW GEAR

Low gear is the primary driving range for the RANGER. High gear is intended for use on hard-packed surfaces with light loads. Whenever the vehicle is left unattended, always place the transmission in PARK.

Always shift into low gear for any of the following conditions.

- Operating in rough terrain or over obstacles
- Loading the vehicle onto a trailer
- Towing heavy loads

Always use low gear for any of the following conditions regardless of the selected throttle control setting.





- Operating in rough terrain or over obstacles.
- Loading the vehicle onto a trailer.
- Towing heavy loads.
- Driving frequently at low RPM or at ground speeds below 11 km/h (7 MPH).

SWITCHES

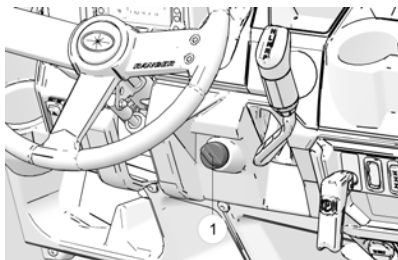
IGNITION SWITCH / LIGHT SWITCH

Use the ignition switch ① to start the engine and to turn the lights on or off. The key can be removed from the switch when it is in the OFF position.



 OFF	Battery Isolator — Electrical circuits are off.
 LIGHTS ON	All lights are ON. Electrical circuits are ON. Electrical equipment can be used.
 POSITION LIGHTS ON	The headlights are OFF. Position lights are ON. Electrical equipment can be used.
 START	Turn the key to the START position to engage the electric starter. See the Starting the Engine section for details.

TURN SIGNAL LEVER

Before turning, activate a turn signal to alert others of your intentions. Check turn signal lamps before each ride.

TIP

The key must be in the ON position to activate the turn signals.

Move the lever upward ① to signal a right turn. The right signal lamps and indicator will flash.

Move the turn signal lever downward ② to signal a left turn. The left turn signal lamps in the taillight and below the front headlight will flash. The turn signal indicator in the gauge will also flash.

Return the lever to the center position to end the signal.

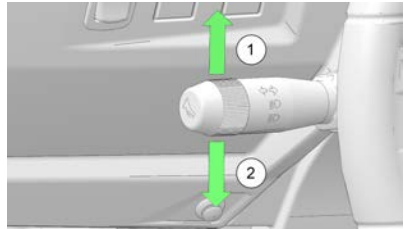

AWD SWITCH

The AWD switch has three positions: All Wheel Drive (AWD), Differential Lock/Two Wheel Drive (2WD) and Off (1WD / Turf Mode).

Press the top of the switch to engage All Wheel Drive (AWD).

Move the switch to the center position to lock the differential and operate in two wheel drive (2WD).

Press the bottom of the switch to unlock the differential and allow the rear drive wheels to operate independently (1WD / Turf Mode). This mode of operation is well suited to turf driving or when active traction is not needed.



FEATURES AND CONTROLS

HAZARD SWITCH

Push the hazard warning switch to cause all turn signal lights to flash simultaneously. Both turn signal indicators on the console will also flash. Use this feature to alert others of an emergency or other situation requiring caution.



ADC SWITCH

The ADC switch has two positions, **ON** and **OFF**. ADC will activate when all of the following conditions are met:

- No throttle applied.
- ADC switch is in the on position.

PARK BRAKE/GLOW PLUG INDICATOR

The park brake indicator illuminates when the park brake is engaged.

The glow plug indicator illuminates when the glow plugs are active. The indicator turns off when the engine is ready to start.

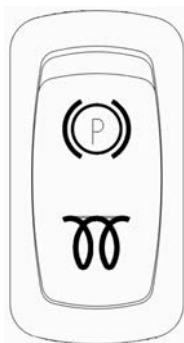

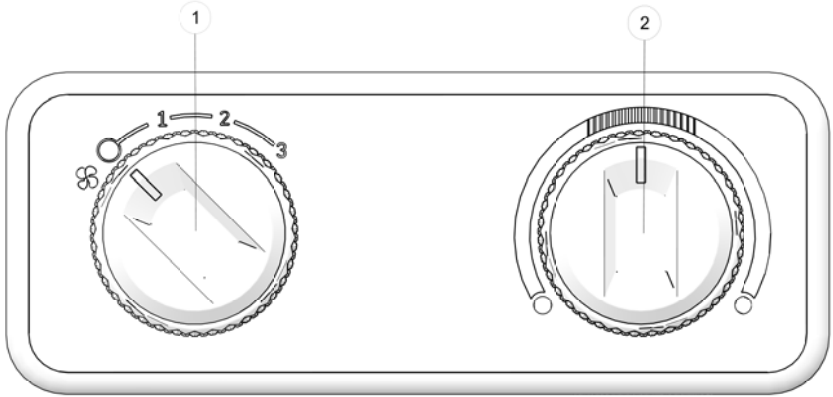
DELUXE MODELS ONLY
HEATER CONTROL PANEL

To operate the cab heater, rotate the fan control ① to the desired fan speed setting. Rotate the fan control completely to the left to turn the fan off. Adjust the temperature by rotating the temperature control ② to the desired heat setting. Rotate the control clockwise to increase the heat setting or counter-clockwise to decrease the heat setting.

FEATURES AND CONTROLS

AUXILIARY OUTLET

The vehicle is equipped with 12-volt accessory outlets on the dash. Use the outlets to power an auxiliary light or other optional accessories or lights. For service, the dash outlet connection is under the dash.



USB PORT

The vehicle is equipped with a USB outlet on the dash. The outlet consists of two USB terminals. For service, the dash outlet connection is under the dash.



BATTERY TRICKLE-CHARGING OUTLET

The vehicle is equipped with a dedicated outlet for trickle-charging the battery during periods of extended inactivity.

If you do not drive the vehicle for more than TWO WEEKS, Polaris recommends using a BatteryMINDER® 2012 AGM - 2 AMP charger, which can be ordered through your dealer.

Polaris provides a charging accessory with your vehicle that allows easy connection to the battery through the Battery Trickle-Charging Outlet, located on the dash. While charging, place the charger outside of the vehicle and protect it from moisture.



THROTTLE/ BRAKE PEDALS

THROTTLE PEDAL

Push the throttle pedal ① down to increase engine speed. Spring pressure returns the pedal to the rest position when released. Always check that the throttle pedal returns normally before starting the engine.

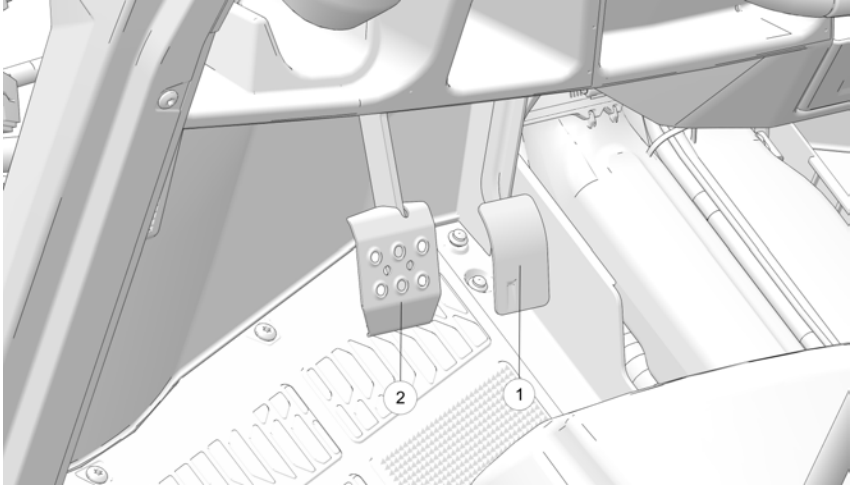

BRAKE PEDAL

Depress the brake pedal ② to slow or stop the vehicle. Apply the brakes while starting the engine.

PARK BRAKE LEVER

Always apply the service brakes before engaging or releasing the park brake. To help prevent the vehicle from rolling, set the park brake when parking the vehicle.

TIP

The park brake will not operate properly if the park brake connector or switch malfunctions or becomes disconnected, or if the switch has moved. See your dealer or other qualified service person promptly if this feature fails to operate properly. If the switch is disconnected, the park brake light will be on and a signal will sound if the engine revs above a certain threshold while the vehicle is not in park.

1. To set the park brake, apply the brakes. Pull the park brake lever towards yourself as far as possible.
2. To release the park brake, apply the brakes. Turn the park brake lever counterclockwise and push it in as far as possible.

SEAT

SEAT BELTS

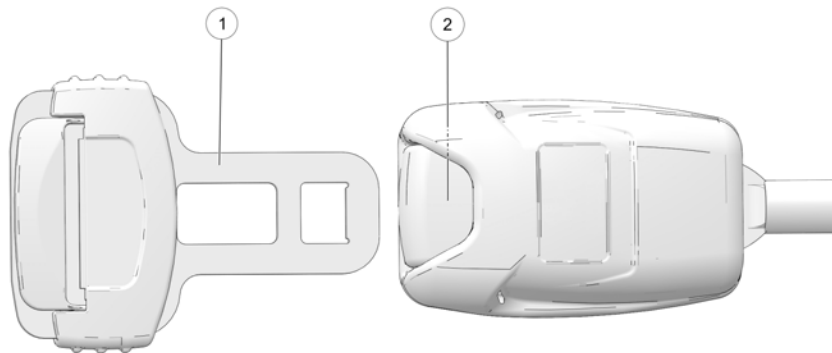

This vehicle is equipped with three-point lap and diagonal seat belts for the operator and passengers. Always make sure the seat belts are secured for all riders before operating. This vehicle is equipped with an Operator Presence Control system that will sound a beeper if the ignition is on, the park brake is off, and the seat belts are not fastened.

WARNING

Falling from a moving vehicle could result in serious injury or death. Always fasten your seat belt securely before operating or riding in the vehicle.

To wear the seat belt properly, follow this procedure:

1. For 3-point belts, pull the seat belt latch ① downward and across your chest toward the buckle at the inner edge of the seat. The belt should fit snugly across your hips and diagonally across your chest. Make sure the belt is not twisted.
2. Push the latch plate ① into the buckle ② until it clicks.
3. Release the strap, it will self-tighten.
4. To release the seat belt, press the square red button in the buckle's center.

FEATURES AND CONTROLS

SEAT BELT INSPECTION



Failure to perform regular inspection can reduce the effectiveness of the seat belt during a crash and could result in serious injury or death.

Inspect all seat belts for proper operation before each use of the vehicle.

1. Push the latch plate into the buckle until it clicks. The latch plate must slide smoothly into the buckle. A click indicates that it's securely latched.
2. Push the red release latch in the middle of the buckle to make sure it releases freely.
3. Pull each seat belt completely out and inspect the full length for any damage, including cuts, wear, fraying or stiffness. If any damage is found, or if the seat belt does not operate properly, have the seat belt system checked and/or replaced by an authorized dealer.
4. To clean dirt or debris from the seat belts, sponge the straps with mild soap and water. Do not use bleach, dye or household detergents. Rinse the entire length of the belt webbing. Use a garden hose to flush out the retractor and latch housings regularly.

SEAT AND STORAGE COMPARTMENTS

The electrical compartment is located under the center seat. Never use this area for storage. A storage bin is located under the passenger seat. To access this storage area, lift up on the front of the passenger seat and raise it to the upright position. Remove the storage bin to access the battery.

Always make sure all seats are properly installed before operating. Push down firmly on the rear of each seat until the latch pins are fully seated into the grommets.

DELUXE MODELS ONLY

UNDERSEAT STORAGE BOX

On certain models, the passenger seat can be lifted to access the underseat dry storage box ①. The lid of the box contains storage for smaller items, whereas the main compartment can hold larger items.

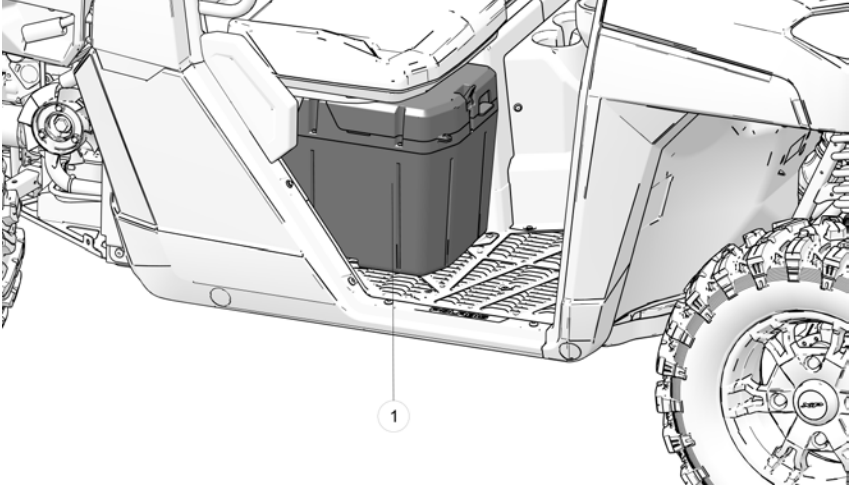

FEATURES AND CONTROLS

SEAT ADJUSTMENTS

The driver's seat is equipped with an adjustment lever. Vertical adjustment of the seat is compensated by adjustment of the steering wheel.

- Pull the adjustment lever to the right to move the seat forward or rearward (150 mm travel distance). The seat back will move together with the seat bottom.
- Once the lever is released, the seat will lock into place.

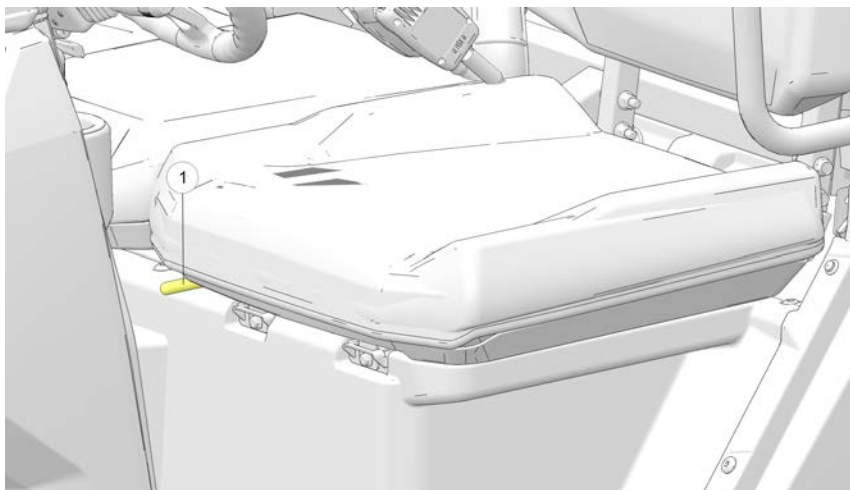

SEAT REMOVAL

Pull up on the rear of the seat. Install the seat by sliding the tabs into the rear of the seat base. Push down firmly on the front of the seat until the pins are fully seated into the grommets.

ELECTRONIC POWER STEERING (EPS)

Electronic power steering engages when the ignition key is turned to the ON position. EPS remains engaged whether the vehicle is moving or idle.

To conserve battery power, the EPS will shut down 5 minutes after the engine is stopped if the key remains in the ON position. The EPS warning indicator will illuminate to indicate the EPS has shut down. Turn the key off and on to reset the unit. If the light remains on after starting the engine, the EPS system is inoperative. Your POLARIS dealer can assist..

FUEL CAP

The fuel tank filler cap ① is located on the left-hand side of the vehicle near the driver's seat. When refueling, always use one of the compatible diesel fuels for this vehicle: B7, B10, or B20. Always ensure that the fuel tank filler cap is fully tightened and secure before operating or transporting the vehicle. Tighten the cap until you hear two clicks.

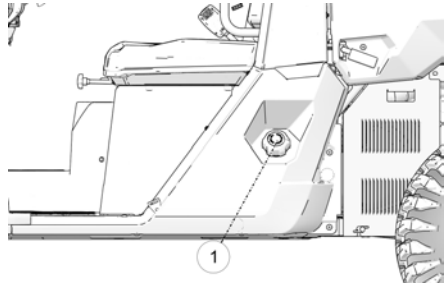

Compatible fuel types: B7, B10, B20

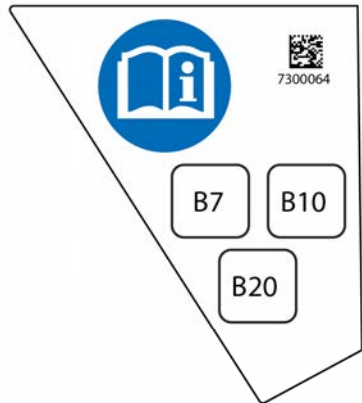

FEATURES AND CONTROLS

CAB NETS

Riding in this vehicle without using the cab nets increases the risk of serious injury or death in the event of an accident or rollover.

Cab nets must be used by both operator and passenger at all times. Make sure all latches are secure before operating the vehicle.

Always inspect cab nets for tightness, wear and damage before each use of the vehicle. Use the strap adjusters to tighten any loose straps. Promptly replace worn or damaged cab nets or latches with new cab nets and latches. Your POLARIS dealer can assist.

SECURING THE NET

1. After entering the vehicle, insert the lower net rod into the net mount on the floor. Make sure the ball at the end of the rod is properly secured in the slot at the base of the mount.
2. Connect the latch at the top edge of the net to the receiver latch mounted on the front frame.

OPENING THE NET

1. To exit the vehicle, release the top front latch.
2. Rotate the net rearward and slide the lower net rod out of the mount to remove it.
3. Allow the net to hang freely outside the vehicle while dismounting.

ROLLOVER PROTECTIVE STRUCTURE (ROPS)

The Rollover Protective Structure (ROPS) on this vehicle meets OECD Code 4 rollover performance requirements. Always have your authorized dealer thoroughly inspect the ROPS if it ever becomes damaged in any way.

No device can assure occupant protection in the event of a rollover. Always follow all safe operating practices outlined in this manual to avoid vehicle rollover.

WARNING

Vehicle rollover could cause severe injury or death. Always avoid operating in a manner that could result in vehicle rollover.

HOOD LATCHES

To remove the hood, rotate the hood latches ① 1/4-turn and lift the hood away from the vehicle.

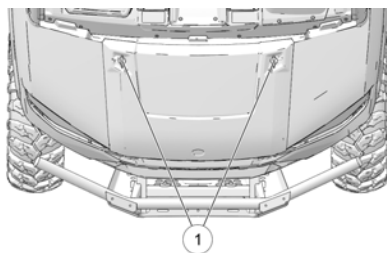

TRAILER HITCH BRACKET

This vehicle is equipped with a receiver hitch bracket for a trailer hitch. To avoid injury and property damage, always heed the warnings and towing capacities outlined in the Towing Loads section.

TRACTOR AND ZUGMASCHINE MODELS ONLY

HITCHES

WARNING

Whenever the vehicle is towing, always stay clear of the area between the vehicle and the towed object. Occupying this area while towing can result in serious injury or death.

REAR HITCH

NOTICE

After 1000 km of use, tighten the bolt holding the trailer ball to the hitch to 445 N·m.

Use the rear hitch for towing a trailer. See the Hauling Cargo section for details and procedures.

The values given below pertain to factory-installed hitches and are provided for informational purposes only.

WARNING

Strictly follow the instructions outlined in the operator's manual of the mounted or trailed machinery or trailer, and not to operate the combination tractor — machine or tractor — trailer unless all instructions have been followed.

IMPORTANT

For vehicle-specific trailering values, see the Specifications chapter. The vehicle-specific values take precedent if they are lower than the component values shown below.

REAR HITCH COMPONENT SPECIFICATIONS

Maximum Vertical Load(s)	100 kg
Maximum Towable Mass	3500 kg
Maximum Dynamic Force (D)	14,0 kN
Approval #	E20 55R-01 3487

REAR HITCH CERTIFICATION LABEL

The hitch certification label is located near the hitch on models equipped with a factory-installed rear hitch.



HITCH REMOVAL / INSTALLATION

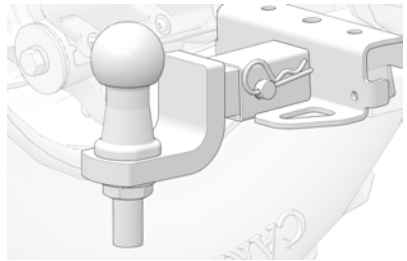
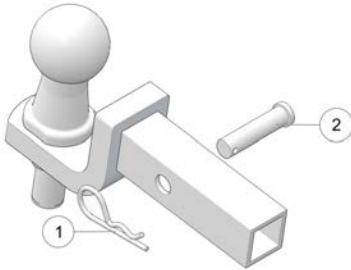

1. To remove the hitch (if equipped), remove the cotter pin ① and hitch pin ②. Remove the hitch, then reinstall the hitch pin ② and secure the cotter pin ①.
2. To install the hitch, remove the cotter pin ① from the hitch pin and remove the hitch pin ②.
3. Install the hitch to the receiver.
4. Reinstall the hitch pin (from the left side of the hitch) through the bore of both the receiver and the hitch.
5. Reinstall the cotter pin. Make sure the hitch assembly is secure at that the cotter pin is properly engaged over the hitch pin.

FEATURES AND CONTROLS

7-WAY TRAILER CONNECTOR

The 7-way trailer connector ① installed on your vehicle meets the requirements of European standard ISO 1724.

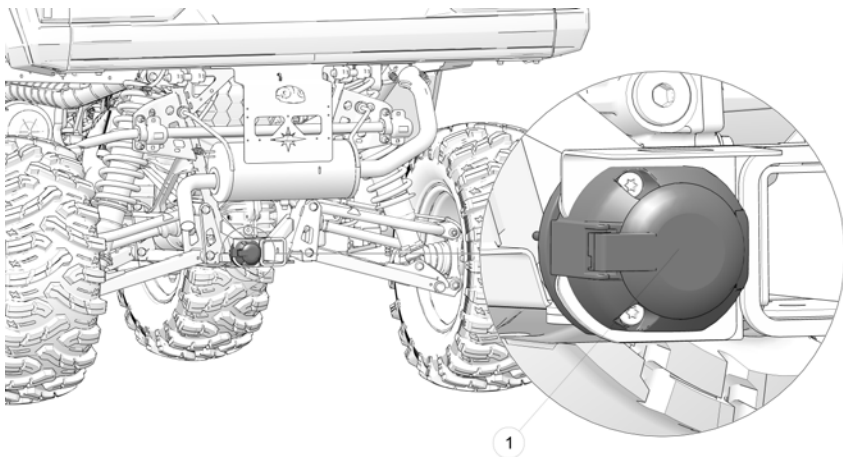

This connector uses all 7 pins on newer model trailers. An older model trailer may not be compatible with this connector.

Improper electrical wiring changes can result in damage to both vehicle and trailer components. When in doubt about your trailer connection, please contact a qualified towbar specialist for assistance.

INSTRUMENT CLUSTER

OVERVIEW

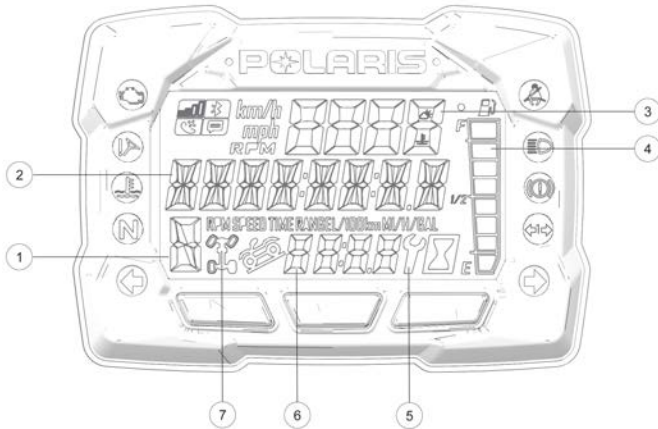

NOTICE







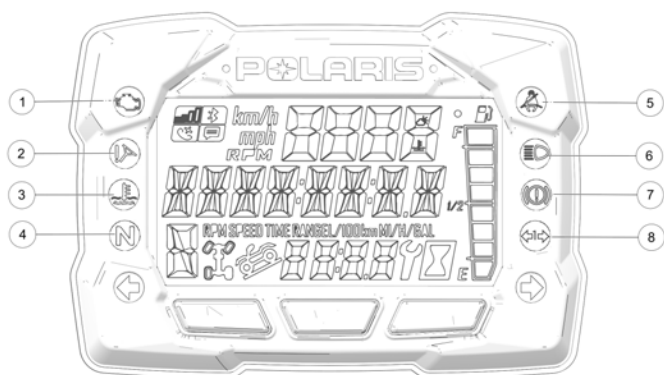

The use of a high pressure washer may damage the instrument cluster. Wash the vehicle by hand or with a garden hose using mild soap. Do not use alcohol to clean the instrument cluster. Do not allow insect sprays to contact the lens. Immediately clean off any gasoline that splashes on the instrument cluster.

<p>① Gear Indicator</p>	<p>H = High Gear L = Low Gear N = Neutral R = Reverse Gear P = Park – = Gear Signal Error (or shifter between gears)</p>
<p>② Display Area 2</p>	<p>This area displays odometer, trip meter, trip meter 2, voltage, engine temperature, engine hour meter, programmable service hour interval, ground speed, or engine RPM.</p>
<p>③ Display Area 1</p>	<p>This area displays engine RPM, ground speed, or coolant temperature.</p>
<p>④ Fuel Gauge</p>	<p>The segments of the fuel gauge show the level of fuel in the fuel tank. When the last segment clears, a low fuel warning is activated. All segments including the fuel icon will flash. Refuel immediately.</p>
<p>⑤ Service Indicator</p>	<p>A flashing wrench symbol alerts the operator that the preset service interval has been reached. Your POLARIS dealer can provide scheduled maintenance. See page 75 for more information.</p>
<p>⑥ Clock</p>	<p>The clock displays time in a 12-hour or 24-hour format.</p>
<p>⑦ Driveline Mode Indicator</p>	<p>Segments of the indicator illuminate based on driveline mode engaged.</p>

FEATURES AND CONTROLS

INDICATOR LAMPS



① Check Engine		This lamp illuminates when the ECM detects a Diagnostic Trouble Code in the engine management system. Do not operate the vehicle if this warning appears. Serious engine damage could result. Your authorized POLARIS dealer can assist.
② EPS Warning		This lamp illuminates to indicate that EPS has shut down. EPS shuts down automatically 5 minutes after the engine is turned off if the key remains in the ON position. Turn the key off and on to reset the unit. If the light remains on after starting the engine, the EPS system is inoperative. Your POLARIS dealer can assist.
③ Engine Hot		This lamp illuminates to indicate an overheated engine. If the indicator flashes, a severe overheating condition exists.
④ Neutral		This lamp illuminates when the transmission is in neutral and the ignition key is in the ON position.
⑤ Helmet/Seat Belt		This lamp flashes for several seconds when the key is turned to the ON position. The lamp is a reminder to wear a helmet and your seat belt.
⑥ High Beam		This lamp illuminates when the headlamp switch is set to high beam.
⑦ Brake Failure (if equipped)		This lamp illuminates when the brake system detects low pressure in the brake hydraulic system.
⑧ Trailer Indicator		This lamp illuminates when the trailer turn signals are active.

DISPLAY AREA 1

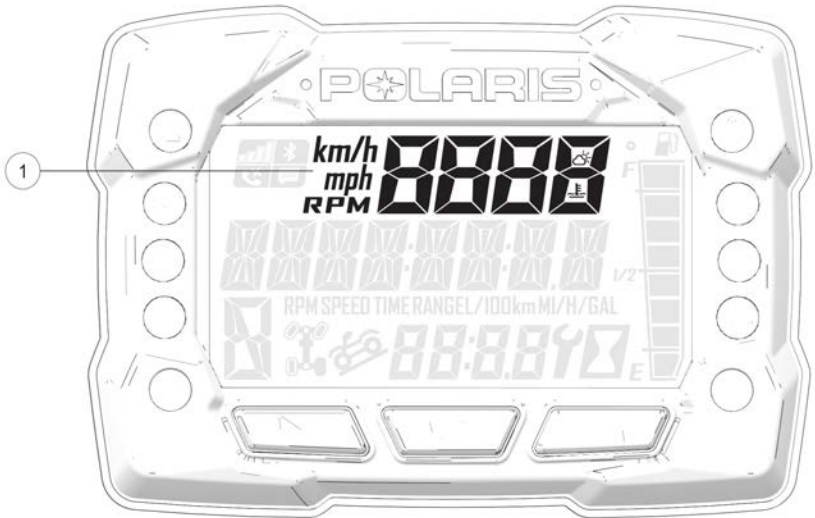

Pressing the MODE button will change the information displayed in Area 1 ①.

Speed



Engine Temperature



RPM



Ambient Temperature (Optional)



FEATURES AND CONTROLS

DISPLAY AREA 2

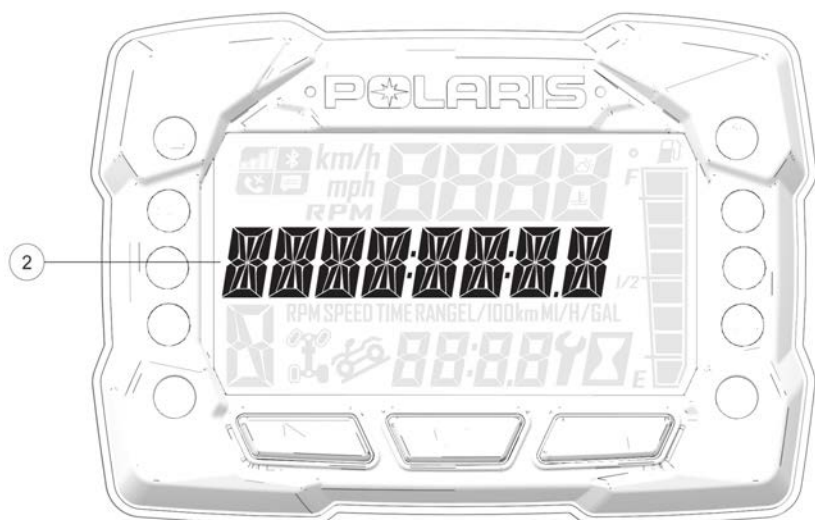

Toggle the Up/Down buttons to change the information displayed in Area 2 ②.

Odometer



Engine Temperature



Trip 1



Ambient Temperature (Optional)



Trip 2



RPM



Voltage

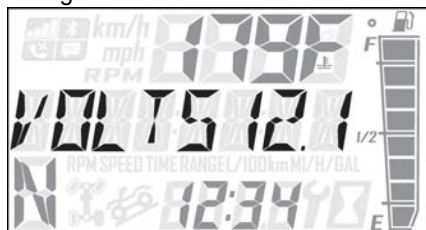

Speed



Engine Hours



Service Hours



FEATURES AND CONTROLS

OPTIONS MENU



Press and hold the MODE button to enter the Options Menu.

OPTIONS MENU	NOTES
Diagnostic Codes	Only displays if fault codes are present or stored
Units - Distance	Select MPH or KPH
Units - Temp	Select between °F and °C
Clock	Select between 12H or 24H, and set time
Backlight Color	Select between Blue or Red
Backlight Level	Set backlight brightness level
Service Hours	View/Set Service hours
Exit Menu	Exit

UNIT SELECTION DISTANCE

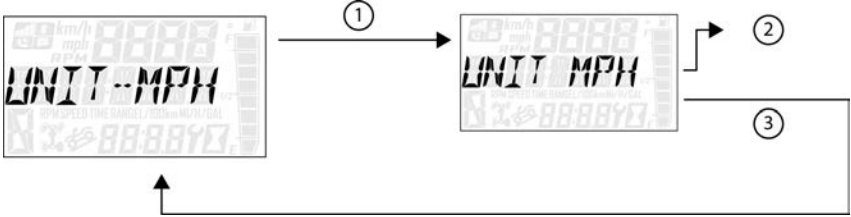

1. Press and hold the MODE button to enter the Options Menu.

NOTICE

"OPTIONS" will display on the screen for 3 seconds before showing first menu item.

2. Select "Units-Distance" from the Options Menu by pressing the MODE button.

Reference the image shown above:

- ① Press the MODE button.
- ② Toggle the Up/Down Buttons to change the units (MPH or KPH)
- ③ With the correct unit displayed, Press the mode button which will set the unit and return to the Options Menu.

3. To exit the Options Menu the user can select Exit Menu function from Options Menu, can hold Mode Button and exit out of Options Menu, or not press any button for 10 seconds, which will exit out of the Options Menu.

FEATURES AND CONTROLS

UNIT SELECTION TEMPERATURE

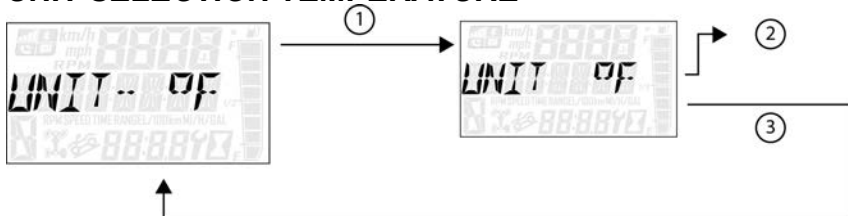

1. Press and hold the MODE button to enter the Options Menu.

NOTICE

"OPTIONS" will display on the screen for 3 seconds before showing first menu item.

2. Select "Units - Temp" from the Options Menu by pressing the MODE button.

Reference the image shown above:

- ① Press the MODE button.
 - ② Toggle the Up/Down Buttons to change the units (°F or °C)
 - ③ With the correct unit displayed, Press the mode button which will set the unit and return to the Options Menu.
3. To exit the Options Menu the user can select Exit Menu function from Options Menu, can hold Mode Button and exit out of Options Menu, or not press any button for 10 seconds, which will exit out of the Options Menu.

CLOCK

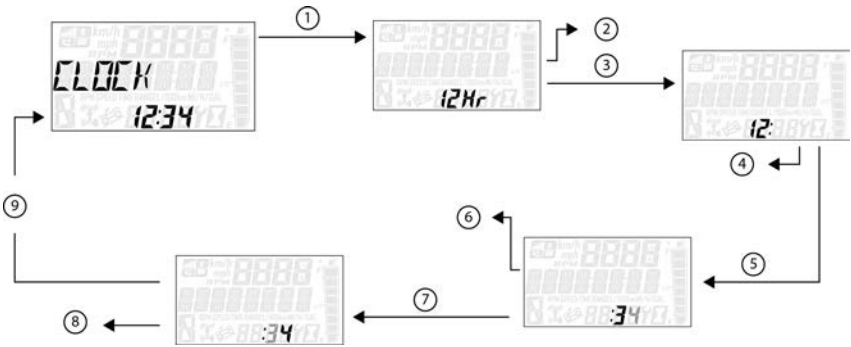

1. Press and hold the MODE button to enter the Options Menu.

NOTICE

"OPTIONS" will display on the screen for 3 seconds before showing first menu item.

FEATURES AND CONTROLS

2. Select "Clock" from the Options Menu by pressing the MODE button.

Reference the image shown above:

- ① Press the MODE button.
 - ② Toggle the Up/Down Buttons to change the units (12H or 24H)
 - ③ With the correct unit displayed, Press the mode button which will set the unit.
 - ④ Toggle the Up/Down Buttons to change the units (Cycles Hours)
 - ⑤ With the correct unit displayed, Press the mode button which will set the unit.
 - ⑥ Toggle the Up/Down Buttons to change the units (Cycles 10s of Minutes)
 - ⑦ With the correct unit displayed, Press the mode button which will set the unit.
 - ⑧ Toggle the Up/Down Buttons to change the units (Cycles 1s of Minutes)
 - ⑨ With the correct unit displayed, Press the mode button which will set the unit and return to the Options Menu.
3. To exit the Options Menu the user can select Exit Menu function from Options Menu, can hold Mode Button and exit out of Options Menu, or not press any button for 10 seconds, which will exit out of the Options Menu.

BACK LIGHT COLOR

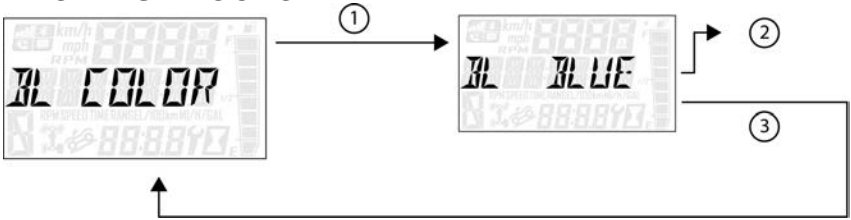

1. Press and hold the MODE button to enter the Options Menu.

NOTICE

“OPTIONS” will display on the screen for 3 seconds before showing first menu item.

2. Select “Backlight Color” from the Options Menu by pressing the MODE button.

Reference the image shown above:

- ① Press the MODE button.
 - ② Toggle the Up/Down Buttons to change the units (Blue or Red)
 - ③ With the correct unit displayed, Press the mode button which will set the unit and return to the Options Menu.
3. To exit the Options Menu the user can select Exit Menu function from Options Menu, can hold Mode Button and exit out of Options Menu, or not press any button for 10 seconds, which will exit out of the Options Menu.

BACK LIGHT LEVEL

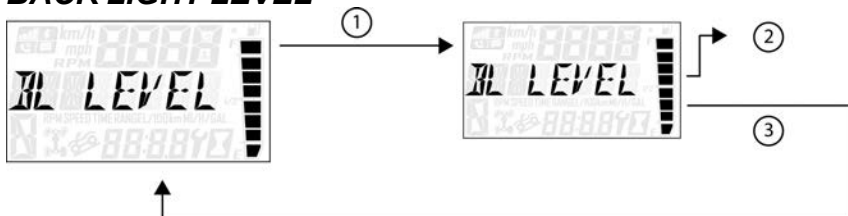

1. Press and hold the MODE button to enter the Options Menu.

NOTICE

“OPTIONS” will display on the screen for 3 seconds before showing first menu item.

2. Select “Backlight Level” from the Options Menu by pressing the MODE button.

Reference the image shown above:

- ① Press the MODE button.
 - ② Toggle the Up/Down Buttons to change the units (Increase or Decrease Level)
 - ③ With the correct unit displayed, Press the mode button which will set the unit and return to the Options Menu.
3. To exit the Options Menu the user can select Exit Menu function from Options Menu, can hold Mode Button and exit out of Options Menu, or not press any button for 10 seconds, which will exit out of the Options Menu.

SERVICE HOURS

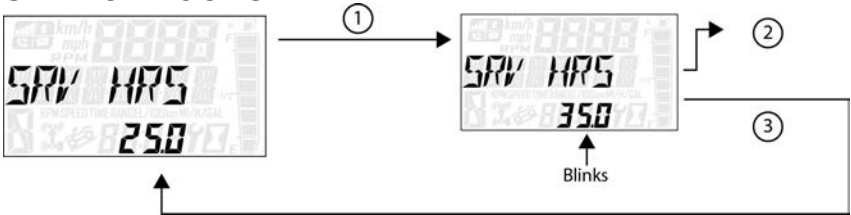

1. Press and hold the MODE button to enter the Options Menu.

NOTICE

"OPTIONS" will display on the screen for 3 seconds before showing first menu item.

2. Select "Service Hours" from the Options Menu by pressing the MODE button.
Reference the image shown above:

- ① Press the MODE button.
- ② Toggle the Up/Down Buttons to change the units (0, 5, 10 - 95, 100)
- ③ With the correct unit displayed, press the MODE button, which will set the unit and return you to the Options Menu.

NOTICE

To reset service hours after they have counted down to "0.0", reselect the existing setpoint or select a new service hour value.

3. To exit the Options Menu the user can select Exit Menu function from Options Menu, can hold Mode Button and exit out of Options Menu, or not press any button for 10 seconds, which will exit out of the Options Menu.

DIAGNOSTIC CODE

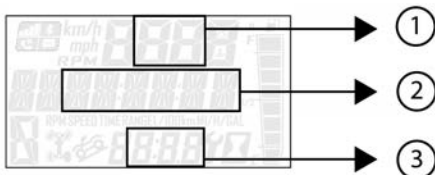

NOTICE

Diagnostic Code Screen will show available MIL that has come on during that ignition cycle.

1. Press and hold the MODE button to enter the Options Menu.

NOTICE

"OPTIONS" will display on the screen for 3 seconds before showing first menu item.

2. Select "Diagnostic Codes" from the Options Menu by pressing the MODE button.

Toggle the Up/Down Buttons to cycle through Code(s).

NOTICE

This option will only be available if a fault code was set or is active during the current ignition key 'on' cycle. Turning off the ignition will clear any save fault codes from the gauge.

Reference the image shown above:

- ① Area A will Display FMI (XX)
 - ② Area B will Display SPN (XXXXXX)
 - ③ Clock Area will Display Count (XXX)
3. To exit the Options Menu the user can select Exit Menu function from Options Menu, can hold Mode Button and exit out of Options Menu, or not press any button for 10 seconds, which will exit out of the Options Menu.

OPERATION

VEHICLE BREAK-IN

ENGINE AND DRIVETRAIN BREAK-IN

1. Fill the fuel tank with the recommended fuel. See the Refueling section for details. Always exercise extreme caution whenever handling fuel.
2. Check the oil level. See the Oil Check section for details. Add the recommended oil as needed to maintain the oil level in the safe operating range.
3. Avoid aggressive use of the brakes.
4. Vary throttle positions. Do not operate at sustained idle.
5. Perform regular checks on fluid levels, controls and areas outlined on the daily pre-ride inspection checklist.
6. Carry only light loads.
7. During the break-in period, change both the oil and the filter at 50 hours or one month, whichever comes first, and every 200 hours thereafter.
8. Check fluid levels of transmission and all gearcases after the first 50 hours of operation and every 200 hours thereafter.

BRAKE SYSTEM BREAK-IN

Apply only moderate braking force for the first 50 stops. Aggressive or overly forceful braking when the brake system is new could damage brake pads and rotors.

OPERATION

PVT BREAK-IN (CLUTCHES / BELT)

A proper break-in of the clutches and drive belt will ensure a longer life and better performance. If a belt fails, always clean any debris from the duct and from the engine compartment.

STANDARD BREAK-IN

Drive at slower speeds for the first 50 miles (80 km) of operation. Carry only light loads. Avoid aggressive acceleration, high-speed operation and prolonged operation at a specific RPM during this period.

SAND / DUNE BREAK-IN

Drive in low gear for the first 5 miles (8 km) of operation. Avoid prolonged low speed operation at high throttle. Avoid aggressive acceleration, high-speed operation and prolonged operation at a specific RPM during this period.

BELT LIFE

To extend belt life, use low gear in the following conditions:

- When hauling or towing heavy cargo
- When consistently operating at speeds less than 35 MPH (56 km/h) in hard-pulling terrain, such as mud, rocks or sand/dune environments.

OPERATING GUIDELINES

BOARDING AND EXITING THE VEHICLE

- Never try to climb onto or exit the vehicle while it is moving.
- Do not exit the vehicle by jumping off.
- Always face the vehicle when boarding or exiting.
- Do not grab controls as hand supports. This may cause inadvertent machine movements.
- Always keep vehicle steps and flooring clean to prevent slippery conditions.

STARTING THE ENGINE

NOTICE

NEVER use an engine starting aid such as ether. Engine damage will result.



The ignition system is marked by the OFF/ Battery Isolator Function ①, LIGHTS ON ②, POSITION LIGHTS ON ③, and START ④ symbols.

Before operating this vehicle in cold weather, review the cold weather operation information on page 82. Always wait for the glow plug indicator light to turn off before cranking the engine.

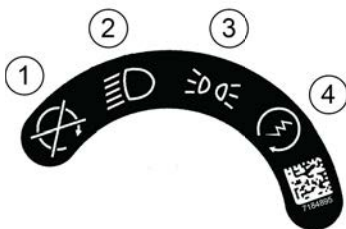

1. Always start the engine outdoors or in a well-ventilated area.
2. Sit in the driver's seat and fasten the seat belt. Secure the cab nets.
3. Place the transmission in PARK.
4. Apply the brakes. Do not press the throttle pedal while starting the engine.
5. Turn the ignition switch to the LIGHTS ON position and wait for the glow plug indicator light to turn off.

OPERATION

6. Turn the ignition key to the START position. Engage the starter for a maximum of five seconds. Release the key when the engine starts. Turn the key to either LIGHTS ON or POSITION LIGHTS ON.
7. If the engine does not start within five seconds, return the ignition switch to the OFF position and wait five seconds. Repeat steps 6 and 7 until the engine starts.

NOTICE

Operating the vehicle immediately after starting could cause engine damage. Allow the engine to warm up for several minutes before operating the vehicle. After letting the engine warm up in this way, operate the vehicle at medium speed without load for several minutes to further warm up the engine.

BRAKING

1. Release the throttle pedal completely.

TIP

When the throttle pedal is released completely and engine speed slows to near idle, the vehicle has no engine braking.

2. Press on the brake pedal evenly and firmly.
3. Practice starting and stopping (using the brakes) until you're familiar with the controls.

DRIVING IN REVERSE

WARNING

Before shifting into reverse, use extra care to make sure the area is clear of people or obstacles. When it's safe to proceed, back slowly.

Follow these precautions when operating in reverse:

1. Always check for obstacles or people behind the vehicle.
2. Apply the throttle *lightly*. Never open the throttle suddenly.
3. Back slowly.
4. Apply the brakes *lightly* for stopping.
5. Avoid making sharp turns.

STOPPING THE ENGINE AND PARKING THE VEHICLE

WARNING

When leaving the vehicle on an incline is unavoidable, use extra care. Vehicle rollaway can cause serious injury or death. This vehicle can roll whenever the gear selector is not in the PARK (P) position. Always shift to PARK (P) when stopping the engine or leaving the vehicle. If leaving the vehicle unattended, block the rear wheels on the downhill side and keep children, pets, and others away from the gear selector.

To park the vehicle:

1. Stop the vehicle on a level surface.
2. Place the transmission in PARK (P). This vehicle can roll whenever the transmission is not in the PARK (P) position.
3. Stop the engine.
4. Engage the park brake (if equipped).
5. Remove the ignition key to prevent unauthorized use.

OPERATION

COLD WEATHER OPERATION

Cold weather operation can result in fuel gelling if the incorrect fuel type is used. Use the following fuel blending guideline to prevent this from occurring.

FUEL BLENDING GUIDELINE		
Temperature	No. 2	No. 1
-9° C (+15° F)	100%	0%
Down to -29° C (-20° F)	50%	50%
Below -29° C (-20° F)	0%	100%

COLD STARTING GUIDELINES				
Temperature (C)	-7° to -9°	-9° to -15°	-15° to -29°	-29° to -32°
Temperature (F)	+20° to +15°	+15° to +5°	+5° to -20°	-20° to -25°
Fuel	#2 Diesel	50/50 mix #1/#2 diesel		#1 Diesel
5W-40 Synthetic Diesel Engine Oil	Optional	Advised	Required	
Battery condition/connections	Charged battery (12.8 VDC)			
Proper glow plug usage (wait for the light)	Wait for light at all temps			
Oil pan heater	Not needed		Optional (helps to reduce cranking)	

NOTICE

- Do not allow the starter motor to run continuously for more than 20 seconds.
- Be sure to warm up the engine, not only in winter, but also in warmer seasons. An insufficiently warmed-up engine can short its service life.
- If the temperature is going to drop below -15° C (5° F), detach the battery from the machine and keep it indoors in a safe area. Reinstall it just before the next operation.

TRACTOR MODELS ONLY

TOWING LOADS

 **WARNING**

Towing improperly can alter vehicle handling and may cause loss of control or brake instability.

Always follow these precautions when towing:

1. Never load more than 100 kg (220 lbs.) tongue weight on the towing bracket.
2. When towing a disabled vehicle, place the disabled vehicle's transmission in neutral. Do not operate the vehicle faster than 16 km/h (10 MPH) when towing.
3. Towing a trailer increases braking distance. Do not operate the vehicle faster than 16 km/h (10 MPH) when towing.
4. Do not tow more than the recommended weight for the vehicle.
5. Attach a trailer to the trailer hitch bracket only. Do not attach a trailer to any other location, which could result in loss of control of the vehicle.
6. The total load (operator, accessories, cargo and weight on hitch) must not exceed the maximum weight capacity of the vehicle.

MODEL	MAXIMUM UN-BRAKED TRAILER MASS	MAXIMUM BRAKED TRAILER MASS	TOTAL TOWED LOAD WEIGHT (15° GRADE)	TOTAL HITCH VERTICAL WEIGHT	MAXIMUM TOWING SPEED
RANGER Diesel	730 kg (1609 lbs.)	1000 kg (2205 lbs.)	386 kg (850 lbs.)	100 kg (220 lbs)	16 km/h (10 MPH)

OPERATION

MD / ZUGMASCHINE MODELS ONLY

TOWING LOADS

 **WARNING**

Towing improperly can alter vehicle handling and may cause loss of control or brake instability.

Always follow these precautions when towing:

1. Never load more than 173 kg (381 lbs.) tongue weight on the towing bracket.
2. When towing a disabled vehicle, place the disabled vehicle's transmission in neutral. Do not operate the vehicle faster than 16 km/h (10 MPH) when towing.
3. Towing a trailer increases braking distance. Do not operate the vehicle faster than 16 km/h (10 MPH) when towing.
4. Do not tow more than the recommended weight for the vehicle.
5. Attach a trailer to the trailer hitch bracket only. Do not attach a trailer to any other location, which could result in loss of control of the vehicle.
6. The total load (operator, accessories, cargo and weight on hitch) must not exceed the maximum weight capacity of the vehicle.

MODEL	TOTAL TOWED LOAD WEIGHT (15° GRADE)	TOTAL HITCH VERTICAL WEIGHT	MAXIMUM TOWING SPEED
RANGER Diesel	386 kg (850 lbs.)	173 kg (381 lbs)	16 km/h (10 MPH)

DUMPING THE CARGO BOX

To dump the cargo box, do the following:

1. Select a level site to dump the cargo box. Do not attempt to dump or unload the vehicle while parked on an incline.
2. Apply the brakes.
3. Shift the gear selector to the Park position.
4. Turn the key to the off position.
5. Dismount vehicle.
6. Ensure that the cargo is positioned evenly or toward the front of the cargo box.
7. Open the tailgate.
8. Stand clear and pull up on the cargo box release lever.
9. Lift the front of the cargo box to dump the cargo.
10. Lower the cargo box and push down securely to latch.
11. Close the tailgate.

WARNING

Operating the vehicle while the cargo box is raised could result in severe injury. The box could close unexpectedly and cause injury to the driver or passenger. The rear tires will also catch the rear of a raised box, damaging the vehicle and creating hazardous driving conditions. Never operate this vehicle with the cargo box in the raised position.

OPERATION

ALL WHEEL DRIVE/REAR DIFFERENTIAL SYSTEM

If your model is equipped with a lockable differential, you can choose to operate with an open differential or a closed differential.

ENGAGING AWD

NOTICE

Switching to AWD while the rear wheels are spinning may cause severe drive shaft and clutch damage. Always switch to AWD while the rear wheels have traction or are at rest.

- ① All-Wheel Drive (AWD)
- ② Differential Lock (2WD)
- ③ Differential Unlock (TURF Mode)

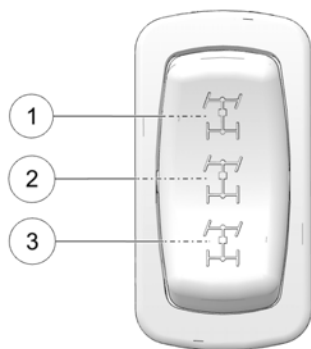

Press the top of the driveline mode switch to engage All Wheel Drive (AWD). The 4X4 indicator illuminates in the rider information center to indicate that the vehicle is in AWD. When the AWD switch is on, the front gearcase will automatically engage any time the rear wheels lose traction. When the rear wheels regain traction, the front gearcase will automatically disengage. There is no limit to the length of time the vehicle may remain in AWD. Initially, the vehicle's electronic system will not enable the AWD until the engine RPM is below 3100. Once enabled, the AWD remains enabled until the switch is turned off. If the switch is turned off while the front gearcase is moving, it will not disengage until the rear wheels regain traction.

Engage the AWD before getting into conditions where front wheel drive may be needed. If the rear wheels are spinning, release the throttle before switching to AWD.

DISENGAGING AWD

Move the driveline mode switch to the center or bottom position to disengage AWD. If the switch is turned off while the front hubs are driving, they will not release until the rear wheels regain traction.

In some situations, the front gearcase may remain locked after turning the AWD switch off. If this occurs, you may notice increased steering effort and some vehicle speed restriction. Perform the following procedure to unlock the front gearcase.

To disengage AWD, do the following:

1. Stop the vehicle.
2. Operate in reverse for at least 3 m.
3. Stop completely.
4. Shift into low gear and drive forward.
5. If the front gearcase remains locked after following these instructions, see your dealer or other qualified service person for service.

LOCKING THE DIFFERENTIAL

Move the switch to the center position to lock the differential and operate in two wheel drive (2WD). Locking the differential in slippery or low traction conditions helps improve traction. When the rear differential is locked, both rear wheels rotate at the same speed.

UNLOCKING THE DIFFERENTIAL (TURF MODE)

When operating in TURF mode, the inside rear wheel will rotate independently from the outside wheel during turns. Operate in TURF mode only as needed to protect smooth, level surfaces from tire damage. DO NOT operate in TURF mode when climbing or descending hills, when sidehilling, or when operating on uneven, loose, or slippery terrain such as sand, gravel, ice, snow, obstacles, and water crossings. Always operate in AWD on these types of terrain.

WARNING

Operating in TURF mode (if equipped) when on sloped, uneven, or loose terrain could cause loss of control and result in serious injury or death. One rear wheel may slip and lose traction or may lift up and grab when it touches the ground again.

Press the bottom of the switch to unlock the differential and allow the rear drive wheels to operate independently (1WD). When the rear differential is unlocked, the rear wheels can rotate at different speeds. Unlock the differential to make maneuvering easier and minimize damage to turf.

NOTICE

Damage to the differential can occur if it is engaged while the vehicle is traveling at high speeds or while the rear wheels are spinning. Slow the vehicle to nearly stopped before engaging the differential.

WARNING

Never operate in TURF mode (if equipped) while operating on a hill or other irregular terrain. Always move the switch to AWD before ascending or descending a hill.

ACTIVE DESCENT CONTROL (ADC) SYSTEM

The ADC system allows engine braking to all four wheels when the vehicle descends a hill or incline.

- *Always operate in low gear and engage ADC 4X4 when transporting heavy loads and/or when towing.*
- *Always operate in low gear and engage ADC 4X4 before ascending or descending a hill.*

ENGAGING ACTIVE DESCENT CONTROL

The ADC system will automatically engage when *both* of the following conditions occur:

- The drive mode must be in the ADC 4X4 position
- The transmission must be in gear (high, low or reverse)

DISENGAGING ACTIVE DESCENT CONTROL

The ADC system will automatically disengage if *at least one* of the following conditions occur:

- The drive mode is changed from the ADC 4X4 position
- The transmission is shifted to neutral or park

FUEL RECOMMENDATIONS

NOTICE

For the best engine performance, to prevent engine damage and to comply with EPA/CARB warranty requirements, use **ONLY** the recommended diesel fuels. Use only **CLEAN** diesel fuel.

POLARIS recommends the following diesel fuels for use in this vehicle:

- Ultra Low Sulfur #2
- #1 Diesel Fuel containing no more than 20% bio-diesel

For more information about recommended diesel fuels and the consequences of using bio-diesel fuel exceeding 20% bio- diesel, see *Additional Technical Fuel Requirements* below.

Diesel fuel should comply with the following world-wide specifications.

DIESEL FUEL SPECIFICATION	LOCATION
ASTM D975 No. 1D S15, S500 No. 2D S15, S500	USA
EN590:96	European Union
ISO 8217 DMX	International
BS 2869-A1 or A2	United Kingdom
JIS K2204 Grade No. 2	Japan
KSM-2610	Korea
GB252	China

REFUELING

Diesel fuel is highly flammable and explosive under certain conditions.

- Always exercise extreme caution whenever handling diesel fuel.
- Always turn off the engine when refueling.
- Always refuel outdoors or in a well ventilated area free of any source of flame or sparks.
- NEVER carry fuel or other flammable liquids on this vehicle. Failure to follow this instruction could lead to serious burn injuries or death.
- Do not smoke or allow open flames or sparks in or near the area where refueling is performed or where diesel fuel is stored.

OPERATION

- Do not overfill the tank. Do not fill the tank neck.
- If diesel fuel spills on your skin or clothing, immediately wash it off with soap and water and change clothing.

ADDITIONAL TECHNICAL FUEL REQUIREMENTS

- The fuel cetane number should be equal to 45 or higher.
- The sulfur content must not exceed 0.5% by volume. Less than 0.5% is preferred. Especially in the U.S.A. and Canada, Ultra Low Sulfur fuel should be used.
- Bio-Diesel fuels.
- NEVER mix kerosene, used engine oil or residual fuels with diesel fuel.
- Water and sediment in the fuel should not exceed 0.05% by volume.
- Keep the fuel tank and fuel-handling equipment clean at all times.
- Poor quality fuel can reduce engine performance and/or cause engine damage.
- Fuel additives are not recommended. Some fuel additives may cause poor engine performance.
- Ash content must not exceed 0.01% by volume.
- Carbon residue content must not exceed 0.35% by volume. Less than 0.1% is preferred.
- Total aromatics content should not exceed 35% by volume. Less than 30% is preferred.
- PAH (polycyclic aromatic hydrocarbons) content should be below 10% by volume.
- Metal content of Na, Mg, Si and Al should be equal to or lower than 1 mass ppm (test analysis method JPI-5S-44-95).
- Lubricity: Wear mark of WS1.4 should be Max. 460µm (0.018 in.) at HFRR test.

BIO-DIESEL FUELS

In Europe and in the United States, as well as some other countries, non-mineral oil based fuel resources such as RME (Rapeseed Methyl Ester) and SOME (Soybean Methyl Ester), collectively known as FAME (Fatty Acid Methyl Esters), are being used as extenders for mineral oil derived diesel fuels.

These B20 diesel fuels must meet certain requirements:

1. The bio-fuels must meet the minimum specifications for the country in which they are used.
 - In Europe, bio-diesel fuels must comply with the European Standard EN14214.
 - In the United States, bio-diesel fuels must comply with the American Standard ASTM D-6751.2.
2. Bio-fuels should be purchased only from recognized and authorized diesel fuel suppliers.

Precautions and concerns regarding the use of bio-fuels:

1. Free methanol in FAME may result in corrosion of aluminum and zinc FIE components.
2. Free water in FAME may result in plugging of fuel filters and increased bacterial growth.
3. High viscosity at low temperatures may result in fuel delivery problems, injection pump seizures and poor injection nozzle spray atomization.
4. FAME may have adverse effects on some elastomers (seal materials) and may result in fuel leakage and dilution of the engine lubricating oil.
5. Even bio-diesel fuels that comply with a suitable standard as delivered will require additional care and attention to maintain the quality of the fuel in the equipment or other fuel tanks. It is important to maintain a supply of clean, fresh fuel. Regular flushing of the fuel system and/or fuel storage containers may be necessary.
6. The use of bio-diesel fuels that do not comply with the standards as agreed to by the diesel engine manufacturers and the diesel fuel injection equipment manufacturers, or bio-diesel fuels that have degraded as per the precautions and concerns above, may affect the warranty coverage of your engine.

B21 To B100 Bio-diesel Fuel Blend Usage

B21 to B100 bio-diesel is not approved for this POLARIS application.

Approved Engines

Only the Kubota® engine series listed below may operate with bio-diesel fuel concentrations up to B20 for POLARIS applications.

OPERATION

NOTICE

Do not exceed bio-diesel fuel blend B20 for this POLARIS application.

- Kubota® 902D

Approved Fuel

NOTICE

Raw pressed vegetable oils are not considered bio-diesel, and are unacceptable for use as fuel in any concentration in Kubota® engines.

Bio-diesel fuel blends up to B20 must comply with the following standards:

- EN14214 (European standard) and/or ASTM D-6751 (American standard).
- All applicable engines may operate with bio-diesel fuel up to a maximum B20 (20% bio- diesel blend) concentration.

Operating Conditions with B20 Bio-diesel Fuel Blends

Engine Warranty

Damages, performance or service concerns determined to be caused by the use of bio-diesel fuel not meeting the specifications outlined above are not considered to be defects in material or factory workmanship and are not covered under warranty. The same applies to damages or other concerns induced by not complying with the recommended operating conditions of Kubota® engines with bio-diesel fuel.

HANDLING FUEL

 **WARNING**

Diesel fuel is flammable and explosive under certain conditions.

- NEVER refuel with the engine running.
- Always refuel outdoors or in a well ventilated area.
- Fill the fuel tank with diesel fuel ONLY. Filling the fuel tank with gasoline may result in a fire and will damage the engine.
- Remove flammable material containers from the box before filling them with fuel.
- Do not smoke or allow open flames or sparks in or near the area where refueling is performed or where fuel is stored.
- Wipe up all spills immediately.
- Keep sparks, open flames or any other form of ignition (match, cigarette, static electricity source) well away when refueling.
- NEVER remove the fuel cap while the engine is running.
- NEVER overfill the fuel tank. Do not fill the tank neck.
- If fuel spills on your skin or clothing, immediately wash it off with soap and water and change clothing.

EMISSION CONTROL SYSTEMS

NOISE EMISSION CONTROL SYSTEM

Do not modify the engine, intake or exhaust components, as doing so may affect compliance with U.S.A. EPA noise control requirements (40 CFR 205) and local noise level requirements.

SPARK ARRESTER

Your POLARIS vehicle has a spark arrester that was designed for on-road and off-road operation. It is required that this spark arrester remain installed and functional when the vehicle is operated.

EXHAUST EMISSION CONTROL SYSTEM

Exhaust emissions are controlled by engine design. A fuel injection system controls fuel delivery. The engine and fuel injection components are set at the factory for optimal performance and are not adjustable.

Your engine is designed to operate on ultra low sulfur diesel fuel only. Use of any other fuel may result in your engine no longer operating in compliance with emissions requirements.

ELECTROMAGNETIC INTERFERENCE

This spark ignition system complies with Canadian ICES-002.

This vehicle complies with the EMC requirements of UN ECE Regulation 10.

Non-ionizing Radiation: This vehicle emits some electromagnetic energy. People with active or non-active implantable medical devices (such as heart monitoring or controlling devices) should review the limitations of their device and the applicable electromagnetic standards and directives that apply to this vehicle.

NON-IONIZING RADIATION

This vehicle emits some electromagnetic energy. People with active or non-active implantable medical devices (such as heart monitoring or controlling devices) should review the limitations of their device and the applicable electromagnetic standards that apply to this vehicle.

CARBON DIOXIDE EMISSIONS

CO₂ Emissions: 1047.4 g/kWh*

*This CO₂ measurement results from testing over a fixed test cycle under laboratory conditions a(n) (parent) engine representative of the engine type (engine family) and shall not imply or express any guarantee of the performance of a particular engine'

MAINTENANCE

PERIODIC MAINTENANCE

Any qualified repair shop or person may maintain, replace or repair the emission control devices or systems on your vehicle. An authorized POLARIS dealer can perform any service that may be necessary for your vehicle. POLARIS also recommends POLARIS parts for emissions-related parts service, however equivalent parts can be used.

It is a potential violation of the Clean Air Act if a part supplied by an aftermarket parts manufacturer reduces the effectiveness of the vehicle's emission controls. Tampering with emission controls is prohibited by federal law.

Owners are responsible for performing the scheduled maintenance identified in this owner's manual.

Careful periodic maintenance will help keep your vehicle in the safest, most reliable condition. Inspection, adjustment and lubrication of important components are explained in the periodic maintenance chart.

Inspect, clean, lubricate, adjust and replace parts as necessary. When inspection reveals the need for replacement parts, genuine POLARIS parts are available from your POLARIS dealer. Equivalent parts may be used for emissions-related service.

Service and adjustments are important for proper vehicle operation. If you're not familiar with safe service and adjustment procedures, a qualified dealer can perform these operations.

Vehicles subjected to heavy or severe use patterns must be inspected and serviced more frequently.

SEVERE USE DEFINITION

- Frequent immersion in mud, water or sand
- Frequent or prolonged operation in dusty environments
- Short trip cold weather operation
- Racing or race-style high RPM use
- Prolonged low speed, heavy load operation
- Extended idle

Pay special attention to the oil level. A rise in oil level during cold weather can indicate contaminants collecting in the oil sump or crankcase. Change oil immediately if the oil level begins to rise. Monitor the oil level, and if it continues to rise, discontinue use and determine the cause. Your dealer can assist.

MAINTENANCE

MAINTENANCE CHART KEY

SYMBOL	DESCRIPTION
XU	Perform these procedures more often for vehicles subjected to severe use.
D	Have an authorized dealer or other qualified person perform these services.

WARNING

Improperly performing the procedures marked with a **D** could result in component failure and lead to serious injury or death. Have an authorized dealer or other qualified person perform these services.

PERIODIC MAINTENANCE CHART

Perform all services at whichever maintenance interval is reached first. Record maintenance and service in the Maintenance Log.

ITEM		MAINTENANCE INTERVAL (WHICHEVER COMES FIRST)			REMARKS
		HOURS	CLNDR	KM (MILES)	
	Engine Oil Level	-	Daily	-	Pre-ride Checklist; check level daily
XU	Coolant	-	Daily	-	Check level daily; replace coolant every 5 years
	Park Brake	-	Daily	-	Inspect; adjust as needed
XU	Engine Fan	-	Daily	-	Inspect; replace as needed
XU	Engine Fan Belt	-	Daily	-	Inspect, correct tension as needed; replace as needed
XU D	Brake Pad Wear	10 H	Monthly	160 (100)	Inspect periodically
	Battery	25 H	Monthly	320 (200)	Check terminals; clean; test
	Fuel System	25 H	Monthly	320 (200)	Inspect; cycle key to pressurize fuel pump; check lines and fittings for leaks and abrasion
XU	Front Gearcase Fluid (Demand Drive)	25 H	1 M	-	Break-in oil level check
XU	Transmission Fluid (AGL)	25 H	1 M	-	Break-in oil level check
XU	Engine Oil / Filter Change (Break-In)	50 H	1 M	1000 (625)	Perform break-in oil / filter change

MAINTENANCE

ITEM		MAINTENANCE INTERVAL (WHICHEVER COMES FIRST)			REMARKS
		HOURS	CLNDR	KM (MILES)	
XU	Seat Adjuster Lubrication	50 H	Monthly	800 (500)	Lubricate long threaded bolt and all pivot pins
XU	General Lubrication	50 H	3 M	800 (500)	Lubricate all fittings, pivots, cables, etc.
XU	Air Filter	50 H	6 M	800 (500)	Inspect (visually – do not remove unless replacement is needed); replace as needed
	Engine Breather	50 H	6 M	800 (500)	Inspect; replace as needed
	Shift Linkage	50 H	6 M	800 (500)	Inspect, lubricate, adjust
D	Steering	50 H	6 M	800 (500)	Lubricate
XU	Front / Rear Stabilizer Bars	50 H	6 M	800 (500)	Lubricate and inspect bushings
D	Throttle Pedal	50 H	6 M	800 (500)	Inspect; adjust; replace as needed
	Throttle Body Intake Ducts/Flange	50 H	6 M	800 (500)	Inspect duct for proper sealing/air leaks
	Cooling System	50 H	6 M	800 (500)	Inspect coolant strength seasonally; pressure test system yearly
XU	Cooling Hoses	50 H	6 M	800 (500)	Inspect for leaks
XU	Radiator	50 H	6 M	800 (500)	Inspect; clean external surfaces
XU	Engine Oil Lines/Fasteners	50 H	6 M	1600 (1000)	Inspect for leaks and loose fittings
XU	Shock Absorbers	50 H	-	800 (500)	Inspect for leaks, loose joints, and wear
	Drive Belt	100 H	12 M	1600 (1000)	Inspect; replace as needed
XU	Front Gearcase Fluid (Demand Drive)	100 H	12 M	1600 (1000)	Change fluid
XU	Transmission Fluid (AGL)	100 H	12 M	1600 (1000)	Change fluid
D	Fuel System	100 H	12 M	1600 (1000)	Check for leaks at tank cap, lines, filter, pump, throttle body, replace if necessary

MAINTENANCE

ITEM		MAINTENANCE INTERVAL (WHICHEVER COMES FIRST)			REMARKS
		HOURS	CLNDR	KM (MILES)	
XU	Engine Mounts	100 H	12 M	1600 (1000)	Inspect, torque to specification; replace if necessary
	Exhaust Muffler / Pipe	100 H	12 M	1600 (1000)	Inspect
	Drive Shafts	100 H	12 M	1600 (1000)	Remove and grease
D	Glow Plug	100 H	12 M	1600 (1000)	Inspect; replace as needed
XU	Wiring	100 H	12 M	1600 (1000)	Inspect for wear, routing, security; inspect connectors subjected to water, mud, etc.
D	Wheel Bearings	100 H	12 M	1600 (1000)	Inspect; replace as needed
XU	Shock Seals	100 H	-	-	Visually inspect shock seals
D	Valve Clearance	150 H	-	5000 (3125)	Inspect; adjust as needed
XU	Engine Oil/Filter Change	200 H	6 M	1600 (1000)	Perform oil / filter change
D	Brake Fluid	200 H	24 M	3200 (2000)	Change every two years
XU D	Clutches (Drive and Driven)	200 H	12 M	3200 (2000)	Inspect; clean; replace worn parts
	Suspension Bushings	250 H	24 M	3200 (2000)	Inspect; replace if necessary
XU D	Shock Absorbers	250 H	-	4000 (2500)	Replace or rebuild (if applicable)
	Spark Arrester	300 H	36 M	4800 (3000)	Clean out
D	Toe Adjustment		-		Inspect periodically; adjust when parts are replaced
	Headlight Aim		-		Adjust as needed

LUBRICATION RECOMMENDATIONS

Check and lubricate all components at the intervals outlined in the Periodic Maintenance Chart, or more often under severe use, such as wet or dusty conditions. Items not listed in the chart should be lubricated at the general lubrication interval.

ITEM	LUBE	METHOD
Engine Oil	Full Synthetic POLARIS Diesel Oil (SAE 5W-40)	Add to proper level on dipstick. See page 104.
Brake Fluid	DOT 4 Brake Fluid	Maintain level between fill lines. See page 137.
Transmission Oil (Main Gearcase)	AGL Gearcase Lubricant & Transmission Fluid	See page 111.
Demand Drive Fluid (Front Gearcase)	Demand Drive Fluid	See page 113.
Suspension (Front and Rear)	Premium All-Season Grease	Locate fittings and grease.
Driveshaft	Premium U-Joint Grease	Locate fittings and grease.

GREASE LUBRICATION POINTS

There are grease fittings at each front and rear torsion bar bushing and on the front propshaft yokes. Apply grease until all traces of water have been purged out at each of these areas.

Greasing Points, Front Suspension ①

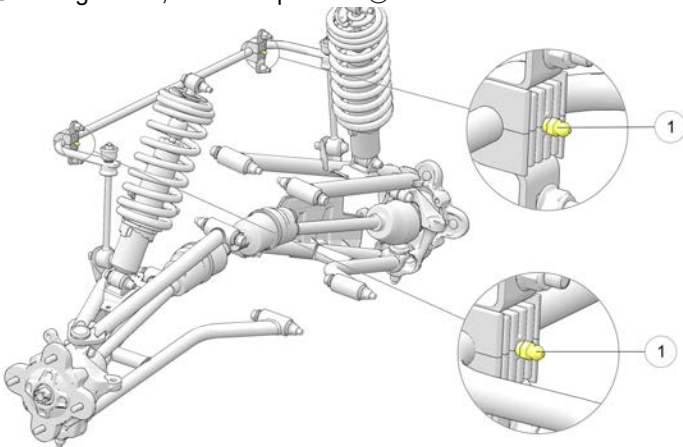

MAINTENANCE

Greasing Points, Rear Suspension ②

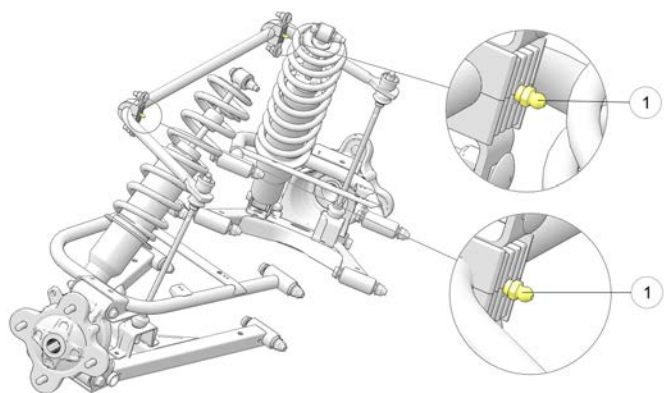

Greasing Point, Driveshaft ③

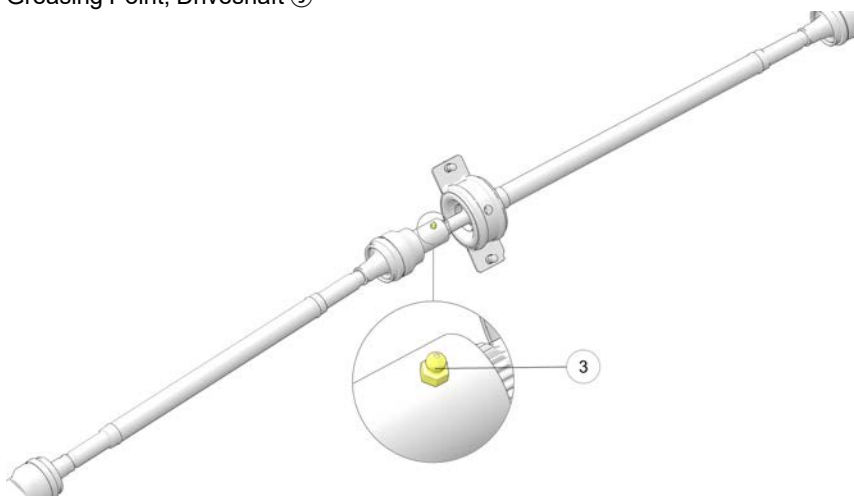

JACKING POINTS

⚠ WARNING

Make sure the vehicle is in park with the parking brake set (if applicable). Use wheel chocks to prevent the vehicle from rolling when the vehicle is raised on a jack. Make sure to use appropriate jack stands, and never work under or around a vehicle that is unsupported. Serious injury may occur.

The vehicle can be lifted from specific points on the vehicle's chassis. Place a suitable jack under the points ① to raise the vehicle. After the vehicle is raised, support the vehicle with a suitable jack stand.

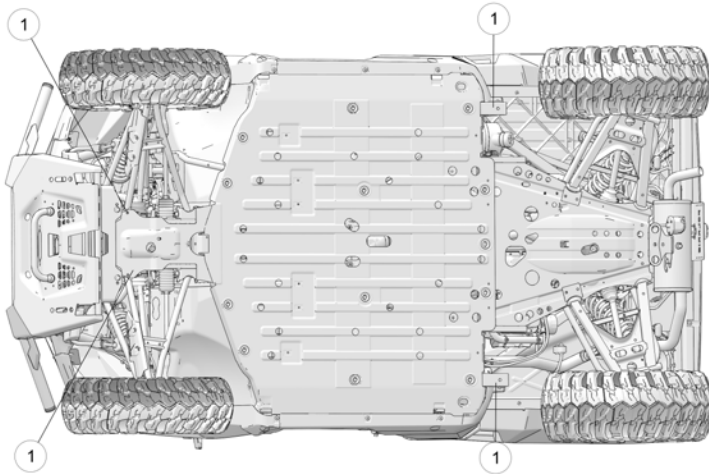

ENGINE OIL

Always check and change the oil at the intervals outlined in the Periodic Maintenance Chart. Always use the recommended engine oil. Always change the oil filter whenever changing oil.

Pay special attention to the oil level. A rise in oil level during cold weather can indicate contaminants collecting in the oil sump or crankcase. Change oil immediately if the oil level begins to rise. Monitor the oil level, and if it continues to rise, discontinue use and determine the cause. Your dealer can assist.

⚠ WARNING

Vehicle operation with insufficient, deteriorated, or contaminated engine oil will cause accelerated wear and may result in engine seizure, accident and injury. Always perform the maintenance procedures as outlined in the Periodic Maintenance Chart.

MAINTENANCE

OIL RECOMMENDATIONS

POLARIS recommends the use of full synthetic POLARIS Diesel Oil (SAE 5W-40) for this vehicle. Always use the correct viscosity grade based on the ambient temperature expected during operation. See the chart below.

NOTICE

Mixing brands or using a non-recommended oil may cause serious engine damage. Always use the recommended oil. Never substitute or mix oil brands.

OIL VISCOSITY / AMBIENT AIR TEMPERATURE CHART

SAE 5W-40			
		SAE 15W-40	
-25 °F (-31 °C)	+5 °F (-15 °C)	+80 °F (+27 °C)	+104 °F (+40 °C)

OIL CHECK

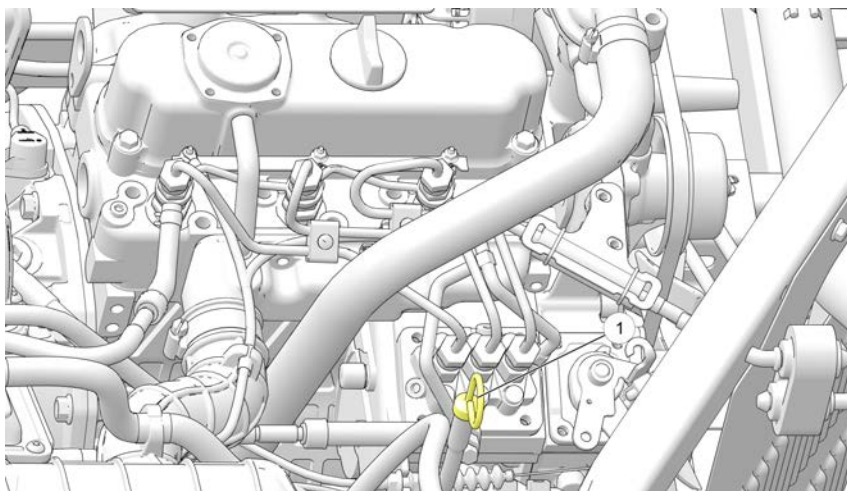

To check the oil, do the following:

1. Position vehicle on a level surface and place the transmission in PARK.
2. Stop the engine and allow it to cool down before removing the dipstick.

3. Raise the cargo box. Remove the dipstick ① and wipe it dry with a clean cloth.
4. Reinstall the dipstick and push it into place.

NOTE

Make certain the dipstick is inserted all the way into the dipstick tube to keep the depth of the dipstick consistent.

5. Remove the dipstick and check the oil level.
6. Add the recommended oil as necessary to bring the oil level within the SAFE range on dipstick. Do not overfill.

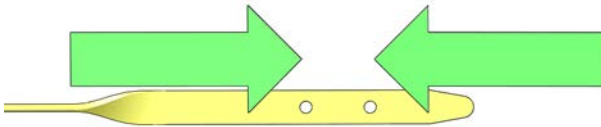

NOTE

A rising oil level between checks during cold weather operation can indicate contaminants such as gas or moisture collecting in the crankcase. If the oil level is over the upper mark, change the oil immediately.

MAINTENANCE

7. With the cargo box raised, add engine oil through the oil fill cap ② located on top of the valve cover, under the cargo box.

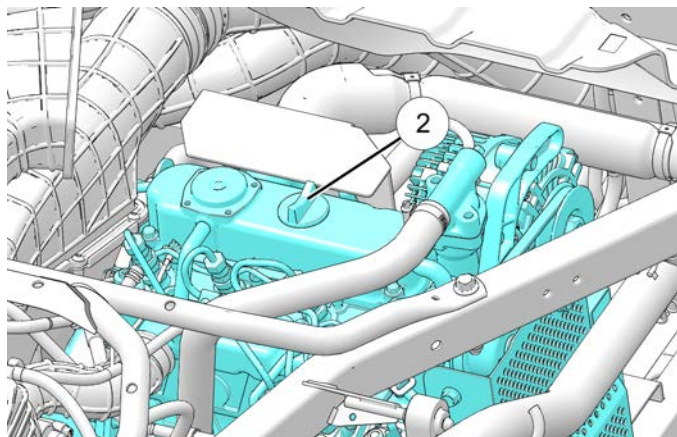

8. When finished, reinstall the dipstick. Lower the cargo box and secure in position.

TIP

Be sure to check around and under the engine for signs of oil leakage.

OIL AND FILTER CHANGE

Always change engine oil and filter at the intervals outlined in the Periodic Maintenance Chart. Always change the oil filter whenever changing the engine oil.

The engine oil fill cap is located on top of the valve cover. Access the oil fill cap by tilting the rear cargo box.

The crankcase drain plug is located on the bottom of the crankcase. Access the drain plug through the skid plate access hole located directly under the crankcase.

1. Position vehicle on a level surface and place the transmission in PARK.
2. Stop the engine and allow it to cool down.
3. Clean the area around the crankcase drain plug.

CAUTION

Use caution when performing this procedure. Do not allow hot engine oil to come into contact with skin, as serious burns may result.

4. Place a drain pan under the engine crankcase and remove the drain plug . Allow the oil to drain completely.

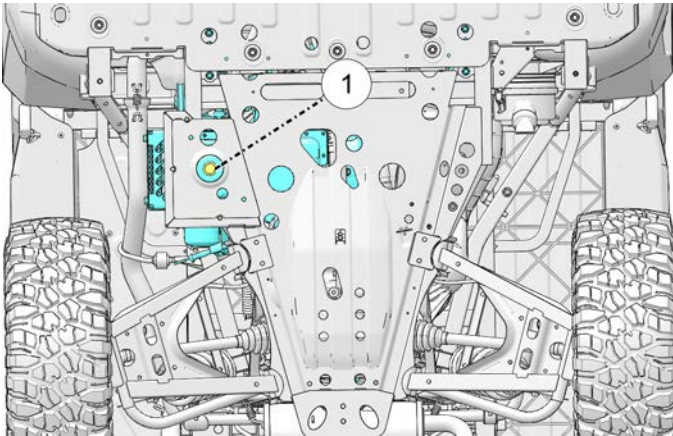

5. Remove all cargo from the cargo box.

CAUTION

Always remove all cargo from the cargo box before lifting the box to access the engine.

MAINTENANCE

6. Pull up on the cargo box release lever to tilt the box.
7. Remove the mud guard by unscrewing its four bolts ②.

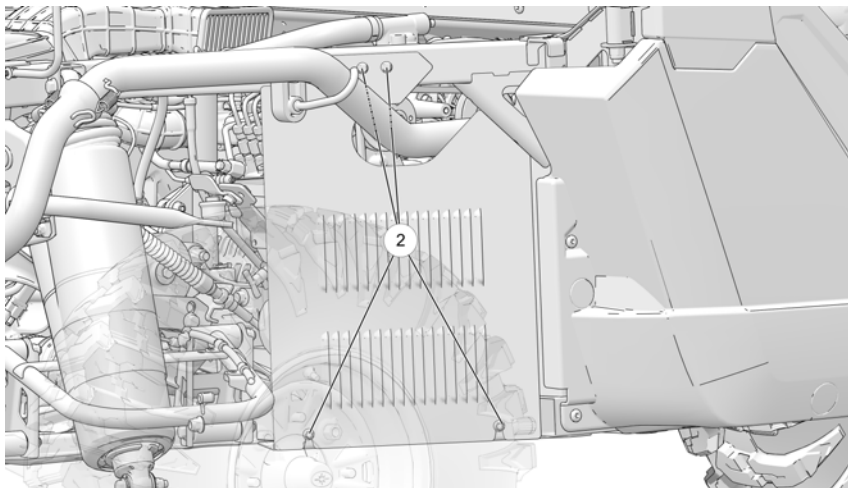

8. Using an oil filter wrench, turn the oil filter ③ counter-clockwise to remove it.

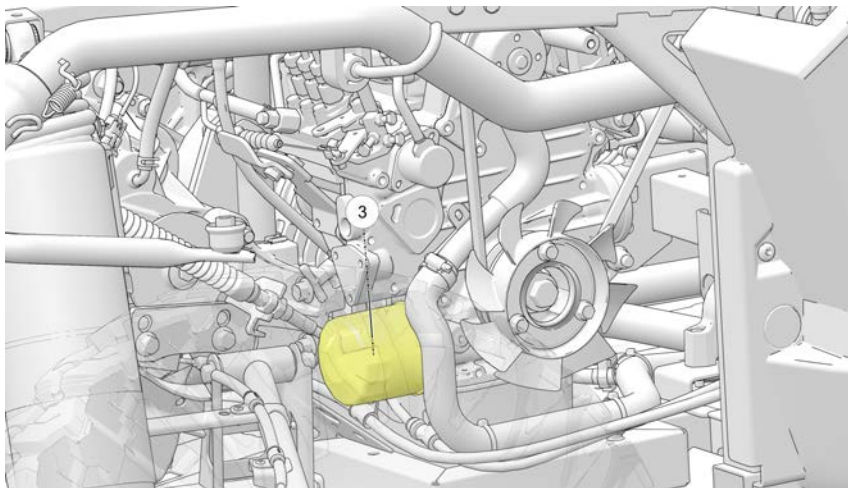

9. Using a clean dry cloth, clean the filter sealing surface on the engine crankcase.

10. Lubricate the O-ring on the new oil filter with a film of fresh engine oil. Check to make sure the O-ring is in good condition.
11. Install the new filter and turn by hand until the filter O-ring contacts the sealing surface, then turn an additional 3/4 turn
12. Replace the sealing washer on drain plug.

NOTICE

The sealing surface on the drain plug should be clean and free of burrs, nicks or scratches.

13. Reinstall the engine crankcase drain plug. Torque the drain plug to 16 Nm (12 ft-lbs).
14. Remove oil fill cap and add 3.7 L (3.9 quarts) of recommended oil. Reinstall the fill cap.
15. Verify the transmission is still in PARK.
16. Start the engine and allow it to idle for 30 seconds.
17. Stop the engine and inspect for oil leaks. Wait at least 15 seconds before removing the dipstick.
18. Remove the dipstick and wipe it dry with a clean cloth.
19. Reinstall the dipstick and push it into place.

NOTICE

Make certain the dipstick is inserted all the way into the dipstick tube to keep the depth of the dipstick consistent.

20. Remove the dipstick and check the oil level.

MAINTENANCE

21. Add the recommended oil as necessary to bring the oil level within the SAFE range on dipstick. Do not overfill.

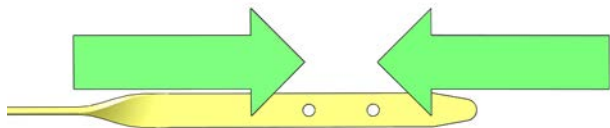

NOTICE

Add oil slowly, to make sure oil does not get into the breather or intake.

22. When finished, reinstall the oil fill cap and oil dipstick.
23. Dispose of used oil and filter properly.

GEARCASES

GEARCASE SPECIFICATION CHART

GEARCASE	LUBRICANT	CAPACITY	FILL PLUG TORQUE	DRAIN PLUG/ LEVEL CHECK PLUG TORQUE
Transmission (Main Gearcase)	AGL Gearcase Lubricant & Transmission Fluid	1550 ml (52 oz.)	14-19 N·m (10-14 ft. lbs.)	14-19 N·m (10-14 ft. lbs.)
Demand Drive Unit (Front Gearcase)	Demand Drive Fluid	300-350 ml (10-12 oz.)	11-14 N·m (8-10 ft. lbs.)	15 N·m (11 ft. lbs.)

TRANSMISSION (MAIN GEARCASE)

TRANSMISSION OIL CHECK

Always check and change the transmission oil at the intervals outlined in the Periodic Maintenance Chart. Maintain the oil level even with the bottom thread of the fill plug hole.

The fill plug is located on the rear of the gearcase. Maintain the fluid level at the bottom of the fill plug hole.

To check the transmission fluid, do the following:

1. Position the vehicle on a level surface.
2. Remove the fill plug ①.
3. Check the fluid level.
4. Add the recommended fluid to the bottom of the fill plug hole. Do not overfill.
5. Reinstall the fill plug. Torque to specification.

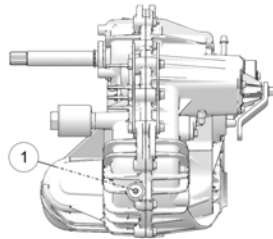

TRANSMISSION OIL CHANGE

The drain plug is located on the bottom of the gearcase. Access the drain plug through the hole in the skid plate.

1. Remove the fill plug ①.
2. Place a drain pan under the drain plug ②.
3. Remove the drain plug. Allow the fluid to drain completely.
4. Clean and reinstall the drain plug. Torque to specification.
5. Add the recommended fluid to the bottom of the fill plug hole. Do not overfill.
6. Reinstall the fill plug. Torque to specification.
7. Check for leaks. Discard used fluid properly.

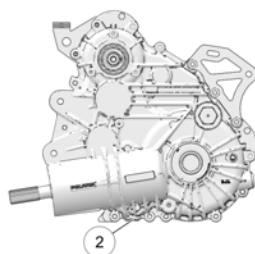

DEMAND DRIVE (FRONT GEARCASE)

DEMAND DRIVE OIL CHECK

Always check and change the demand drive fluid at the intervals outlined in the Periodic Maintenance Chart. Maintain the oil level even with the bottom thread of the fill plug hole. Refer to the Gearcase Specifications Chart for recommended lubricants, capacities and torque specifications.

The front gearcase fill plug ① is located on the right side of the front gearcase.

1. Position the vehicle on a level surface.
2. Remove the fill plug ①. Check the oil level.
3. Add the recommended oil as needed.
4. Reinstall the fill plug. Torque to specification.



DEMAND DRIVE OIL CHANGE

1. Support the vehicle securely with a jackstand.
2. Remove the front tire on the passenger's side for ease of access (optional).
3. Remove the fill plug.
4. Place a drain pan under the drain plug ② on the bottom right-hand side.
5. Remove the drain plug. Drain the oil.
6. Clean and reinstall the drain plug. Torque to specification.
7. Add the recommended fluid to the bottom of the fill plug hole. Do not overfill.
8. Reinstall the fill plug. Torque to specification.
9. Check for leaks.
10. Discard used oil properly.

COOLING SYSTEM

The engine coolant level is controlled or maintained by the recovery system. The recovery system components are the overflow bottle, radiator filler neck, radiator pressure cap and connecting hose.

As coolant operating temperature increases, the expanding (heated) excess coolant is forced out of the radiator, past the pressure cap, and into the overflow bottle. As engine coolant temperature decreases, the contracting (cooled) coolant is drawn back up from the tank, past the pressure cap, and into the radiator.

Some coolant level drop on new vehicles is normal as the system is purging itself of trapped air. Observe coolant levels and maintain as recommended by adding coolant to the overflow bottle.

ADDING OR CHANGING COOLANT

POLARIS recommends the use of POLARIS Antifreeze 50/50 Premix. This antifreeze is already premixed and ready to use. Do not dilute with water.

To ensure that the coolant maintains its ability to protect the engine, we recommend that the system be completely drained every five (5) years and fresh Antifreeze 50/50 Premix added.

Any time the cooling system has been drained for maintenance or repair, replace the coolant with fresh Antifreeze 50/50 Premix. If the recovery bottle has run dry, the level in the radiator should be inspected. Add coolant as needed.

RADIATOR AND COOLING FAN

Always check and clean the screen and radiator fins at the intervals outlined in the Periodic Maintenance Chart. Do not obstruct or deflect air flow through the radiator by installing unauthorized accessories in front of the radiator or behind the cooling fan. Interference with the radiator air flow can lead to overheating and consequent engine damage.

NOTICE

Washing the vehicle with a high-pressure hose could damage the radiator fins and impair the radiator's effectiveness. Using a high-pressure system is not recommended.

RADIATOR COOLANT LEVEL

Always check and clean the screen and radiator fins at the intervals outlined in the Periodic Maintenance Chart. Do not obstruct or deflect air flow through the radiator by installing unauthorized accessories in front of the radiator or behind the cooling fan. Interference with the radiator air flow can lead to overheating and consequentially, engine damage.

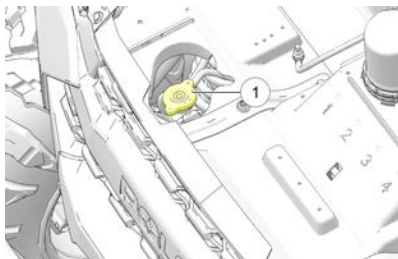

1. Lift the hood.

CAUTION

Escaping steam can cause burns. Never remove the pressure cap while the engine is warm or hot. Always allow the engine to cool before removing the pressure cap.

2. Slowly remove the radiator cap ①.
3. View the coolant level through the opening.
4. Use a funnel and slowly add coolant as needed.

TIP

This procedure is required only if the cooling system has been drained for maintenance and/or repair. But if the overflow bottle has run dry, the level in the radiator should also be inspected.

5. Reinstall the pressure cap. Use of a non-standard pressure cap will not allow the recovery system to function properly. Your POLARIS dealer can provide the correct replacement part.

MAINTENANCE

OVERFLOW BOTTLE COOLANT LEVEL

Always check and change the coolant at the intervals outlined in the Periodic Maintenance Chart. Maintain the coolant level between the minimum and maximum marks on the bottle (when the fluid is cool).

1. Position the vehicle on a level surface.
2. Lift the hood. View the coolant level in the overflow bottle ②.
3. If the coolant level is below the safe operating range, lift the hood and locate the overflow bottle lid. Remove the cap and use a funnel to add coolant through the filler opening. Reinstall the cap.

TIP

If coolant must be added often, or if the overflow bottle runs completely dry, there may be a leak in the system. Your dealer can inspect the cooling system.

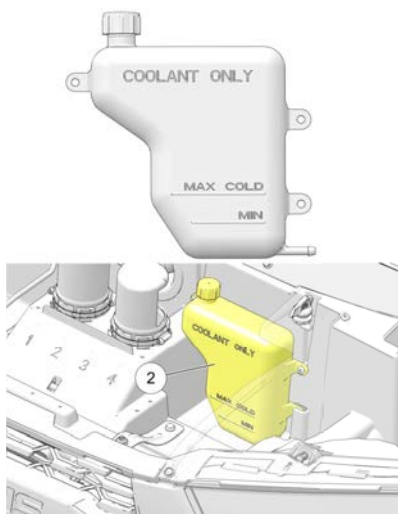

POLARIS VARIABLE TRANSMISSION (PVT) SYSTEM

WARNING

Failure to comply with the instructions in this warning can result in severe injury or death. Do not modify any component of the PVT system. Doing so may reduce its strength so that a failure may occur at a high speed. The PVT system has been precision balanced. Any modification will cause the system to be out of balance, creating vibration and additional loads on components.

The PVT system rotates at high speeds, creating large amounts of force on clutch components. As the owner, you have the following responsibilities for your own safety and the safety of others:

- Always follow all recommended maintenance procedures. Always look for and remove debris inside and around the clutch and vent system when replacing the belt.
- See your dealer or other qualified service person as outlined in the owner's manual.
- This PVT system is intended for use on POLARIS products only. Do not install it in any other product.
- Always make sure the PVT housing is securely in place during operation.

MAINTENANCE

BELT REMOVAL

If a belt fails, always clean any debris from the clutch air duct and from the clutch and engine compartments when replacing the belt.

WARNING

Failure to remove ALL debris when replacing the belt could result in vehicle damage, loss of control and severe injury or death.

NOTE

Inspect the entire clutch outlet duct (including the outlet duct screen) when replacing a drive belt. Remove any debris found in the outlet duct or outlet duct screen.

To remove the belt, do the following:

1. Remove the mud guard by unscrewing its two bolts .

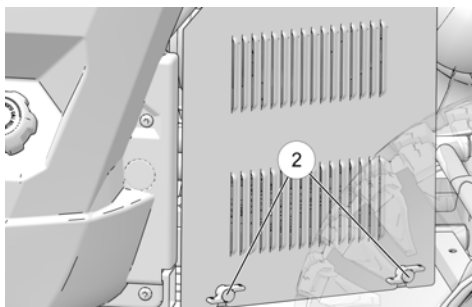

2. Remove the nine fasteners  that retain the outer clutch cover.

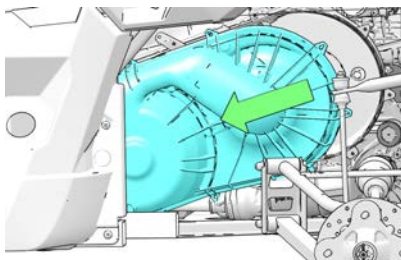
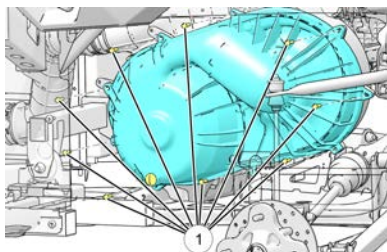

NOTE

Removal of left rear wheel or left rear shock is NOT necessary for belt replacement.

3. Pull the clutch cover forward and slide towards the front of the vehicle as shown above.
4. Rotate the clutch cover back and lift up and over the control arm mounting ②.

NOTE

Use care when lifting clutch cover upwards. Do not damage cover, intake boot, or electrical harness.

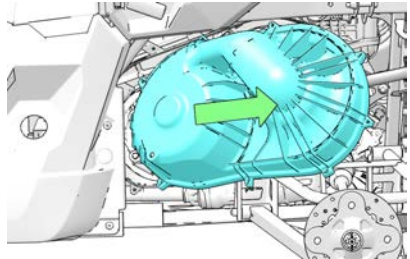
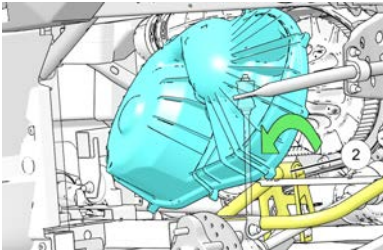

5. Pull clutch cover out towards the rear of the vehicle as shown above.
6. Mark the drive belt direction of rotation so that it can be installed in the same direction.

MAINTENANCE

7. Insert clutch spreader tool ③ into threaded hole on driven clutch as shown and turn clockwise to spread clutch.

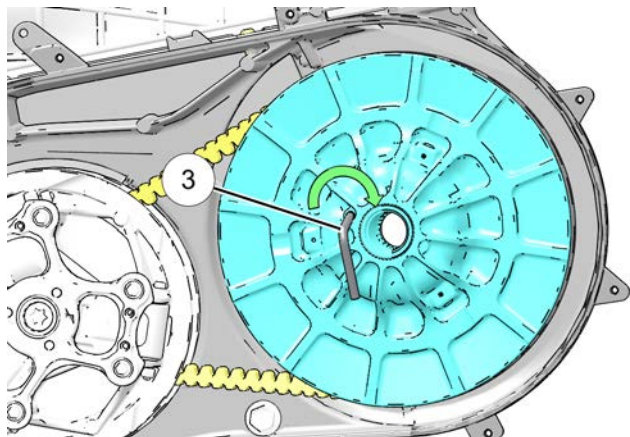

NOTE

Clutch spreader tool part number 2875911 is found in vehicle tool kit.

8. Walk the belt out of the driven clutch and drive clutch. Remove the belt from the vehicle.

BELT INSPECTION

To inspect the drive belt, do the following:

1. Inspect belt for hour-glassing (extreme circular wear in at least one spot and on both sides of the belt). Hour glassing occurs when the drive train does not move and the drive clutch engages the belt.
2. Inspect belt for loose cords, missing cogs, cracks, abrasions, thin spots, or excessive wear. Compare belt measurements with a new drive belt. Replace if necessary.
3. Belts with thin spots, burn marks, etc., should be replaced to eliminate noise, vibration, or erratic PVT operation.

BELT INSTALLATION

NOTE

Be sure to install belt in the same direction as it was removed.

1. With the clutch spreader tool ① installed, loop the belt over the drive clutch and over the driven clutch.

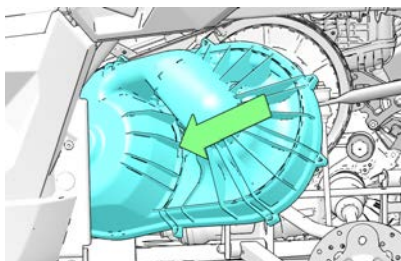
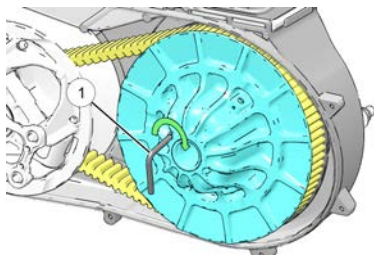

2. Rotate the driven clutch and walk the belt into the clutch.
3. Remove the clutch spreader tool from driven clutch.
4. Rotate / spin the driven clutch and belt approximately 5-7 times to properly seat the belt in the driven clutch.
5. Install the clutch cover into wheel well as shown above.
6. Rotate clutch cover over A-Arm ② as shown below. Use care not to damage intake boots or electrical harness.
7. Pull clutch cover backwards and align with bolt holes on inner clutch cover as shown below.

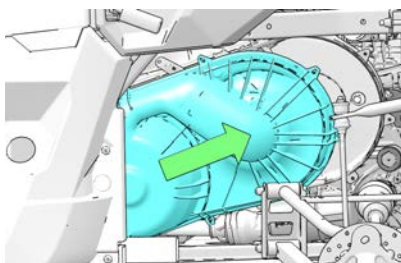
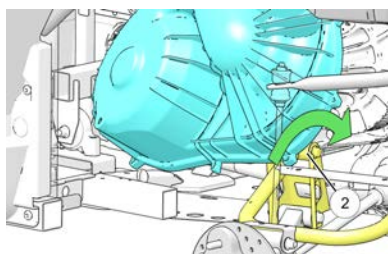

8. Install and torque the outer clutch cover bolts to specification.

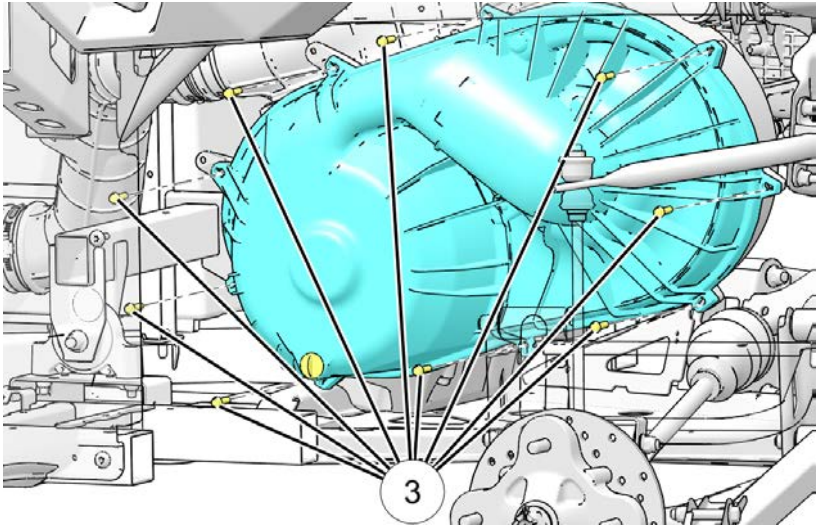

TORQUE

PVT Outer Cover Fasteners
35 in-lbs (4 Nm)

9. Reinstall the mud guard.

POLARIS VARIABLE TRANSMISSION (PVT) DRYING

There may be some instances when water is ingested into the PVT system. Use the following instructions to dry it out before operating:

1. Position the vehicle on a level surface.
2. Remove the red drain plug on the outer clutch cover. Allow the water to drain completely. Reinstall the drain plug.
3. Place the transmission in PARK.
4. Start the engine.
5. Apply varying throttle for 10-15 seconds to expel the moisture and air-dry the belt and clutches. Do not hold the throttle wide open for more than five (5) seconds.
6. Allow the engine RPM to settle to idle speed. Apply the brakes. Shift the transmission to the lowest available range.
7. Test for belt slippage. If the belt slips, repeat the process.
8. Your vehicle requires service as soon as possible. Your POLARIS dealer can assist.

VEHICLE IMMERSION

 **WARNING**

If your vehicle becomes immersed, major engine damage can result if the machine is not thoroughly inspected. Take the vehicle in for service before starting the engine. Your POLARIS dealer can provide this service.

If it's impossible to take your RANGER to a dealer before starting it, follow the steps outlined below:

1. Move the vehicle to dry land or at the very least, to water below the footrests.
2. Dry any water present in the air box. Filter replacement is required if water is present.
3. Remove the glow plugs. Turn the engine over several times using the electric start.
4. Dry the glow plugs and reinstall, or replace with new plugs.
5. Attempt to start the engine. If necessary, repeat the drying procedure.

6. Take the vehicle in for service as soon as possible, whether you succeed in starting it or not. Your POLARIS dealer can provide the required service.
7. If water has been ingested into the PVT follow the procedure for drying.

FILTER SYSTEMS

AIR FILTER REPLACEMENT

Inspect the air filter at the intervals outlined in the Periodic Maintenance Chart. In extremely dusty conditions, air filter replacement will be required more often.

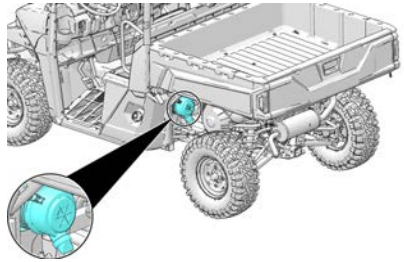

1. To access the airbox, remove the mudguard from the left side of the unit. See page 132.
2. Locate the air filter on the left side of the unit.
3. Release the two airbox ② cover latches.

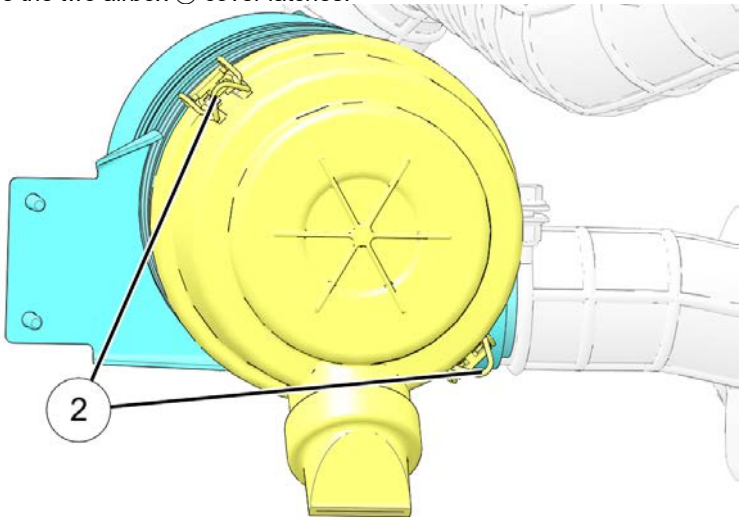

MAINTENANCE

4. Remove the cover ③ to access the air filter element ④.

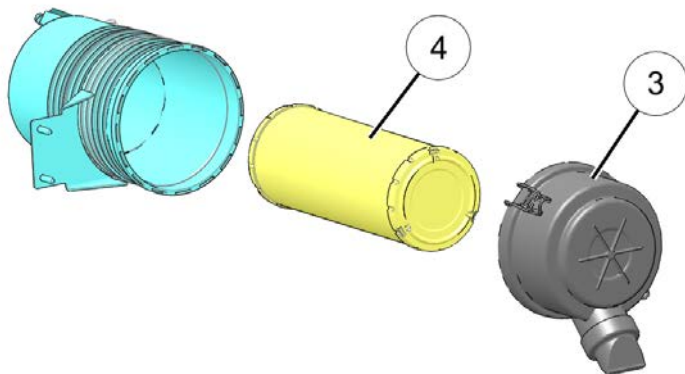

5. Inspect the airbox for oil or water deposits. Wipe away any deposits with a clean shop towel.

IMPORTANT

If the filter has been soaked with fuel or oil it must be replaced.
DO NOT attempt to clean the air filter.

6. Place the air filter into the airbox. Reposition the airbox cover and install the two retaining latches.

NOTICE

Make sure the hinge pins are properly seated when reassembling the airbox

SPARK ARRESTER

 **WARNING**

Failure to heed the following warnings while servicing the spark arrester could result in serious injury or death.

- Do not perform service on the spark arrester while the system is hot. Exhaust system temperatures can reach 1000° F. Allow components to cool sufficiently before proceeding.
- Remove any combustible materials from the area.
- Wear eye protection and gloves.
- Do not stand behind or in front of the vehicle while purging.
- Never run the engine in an enclosed area. Exhaust contains poisonous carbon monoxide gas that can cause loss of consciousness or death in a very short time.
- Never operate without the spark arrester.
- Never go under the vehicle while it's inclined.

Use the following procedure to periodically purge accumulated carbon from the exhaust pipe.

1. Remove the arrester clean-out plug located on the bottom of the muffler.
2. Place the transmission in PARK.
3. Start the engine.
4. Purge accumulated carbon from the system by momentarily revving the engine several times.

MAINTENANCE

5. If carbon is expelled, cover or plug the exhaust outlet and rap on the pipe around the clean-out plug ① while revving the engine several more times.

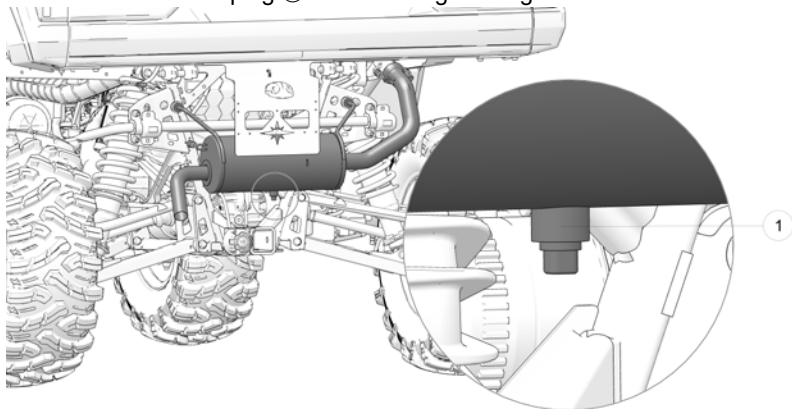

6. If particles are still suspected to be in the muffler, elevate the rear of the vehicle one foot higher than the front. Block the wheels.
7. Repeat steps 4 and 5 until no more particles are expelled when the engine is revved.
8. Stop the engine. Allow the arrester to cool.
9. Reinstall the arrester plug and remove the outlet cover or plug.

INTAKE SCREENS

An engine intake screen (if equipped) is located on the driver's side of the vehicle. A clutch intake screen (if equipped) is located on the passenger side of the vehicle.

Inspect the screens before each use of the vehicle. Remove all dirt and debris from the screens and clean them frequently with warm soapy water

ALTERNATOR BELT

Belt Adjustment

Check the alternator belt at the correct service interval as outlined in the Periodic Maintenance Chart.

Stop the machine on a flat level surface. Put the gear selector in Park, stop the engine and exit the vehicle. See the Stopping the Engine section.

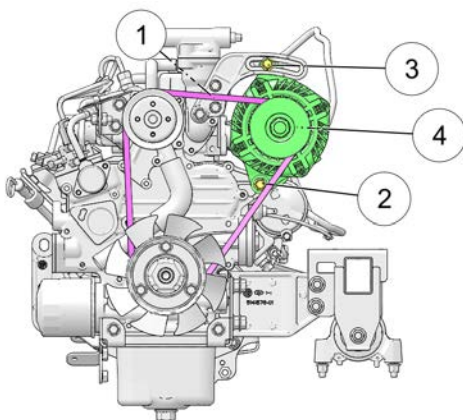

1. Raise the cargo box.
2. The belt tension is correct with 7.6 mm (0.3 in.) of belt deflection at the mid span at the top of the belt ①, when 89 N (20 lbf) is applied to the belt.
3. If the belt tension is not correct, loosen the mounting bolt ② and adjustment bolt ③.
4. Move the top of the alternator ④ to tighten the belt.
5. Tighten the mounting bolt to 23.5-27.5 Nm (17.3-20.3 ft-lbs).
6. Tighten the adjustment bolt to 23.5-27.5 Nm (17.3-20.3 ft-lbs).
7. Lower the cargo box.

FUEL FILTER / WATER SEPARATOR

The fuel filter/water separator is located under the driver's seat, between the engine and fuel tank. Inspect the separator *daily* for leaks. Drain water and replace the separator at the intervals outlined in the Periodic Maintenance Chart. Service the separator more frequently if the vehicle is operated with inferior fuel.

CAUTION

Both fuel and water will drain from the separator during the following procedure. Use caution and observe all fuel safety precautions when handling fuel.

1. Remove the seat and storage tray. Disconnect the battery.
2. Place an appropriate container under the fuel filter drain to catch fluids (water and fuel).
3. Lift the cargo box to access the bleed screw ①. Slightly loosen the bleed screw to relieve fuel pressure in the filter. Do not tighten the screw at this time.

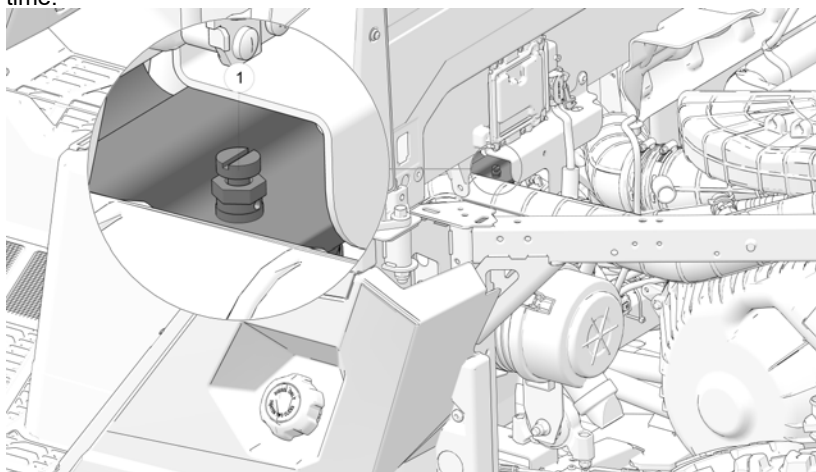

4. Reach under the fuel filter and loosen the drain valve ② no more than one full turn until the fluids drain from the drain hole. Do not completely unscrew the drain valve.

IMPORTANT

The drain valve has standard threads.

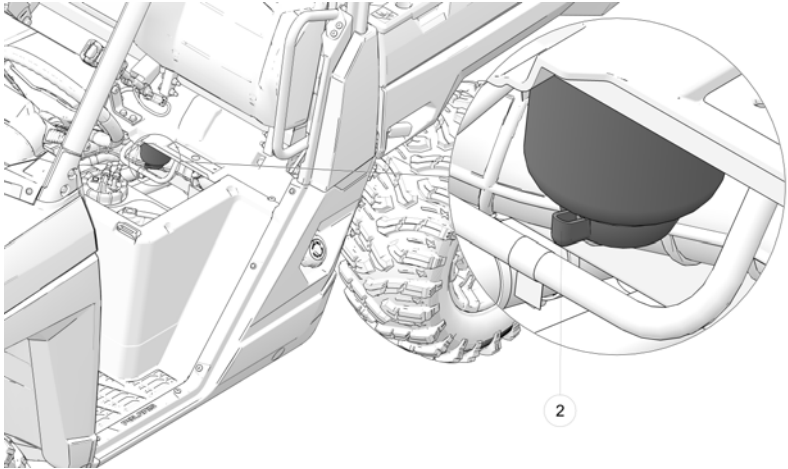

5. When fluids stop draining from the valve, tighten the valve firmly (by hand only).
6. Clean off any excess fuel.
7. Reconnect the battery.
8. Turn the ignition key on to engage the fuel pump. Leave the key on only until fuel begins to spit from the bleed screw, then tighten the screw.
9. Clean up any spilled fuel and soiled shop towels properly.
10. Cycle the key switch from OFF to ON six times, waiting three seconds at each "ON" cycle to allow the fuel pump to cycle.
11. Start the engine and check for fuel leaks.
12. Reinstall the seat and storage tray.

MUD GUARD REMOVAL/ INSTALLATION

1. Remove the two (2) lower fasteners ① from the mudguard.

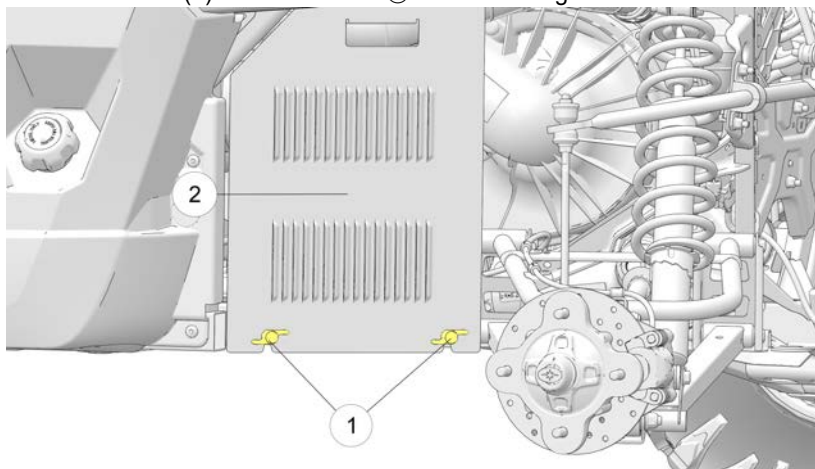

NOTICE

The rear wheel may be removed if needed for easier access and removal of the mudguard.

2. Carefully pull the mudguard ② toward the wheel. Remove the mudguard. Install the mudguard by reversing the procedure.

THROTTLE SYSTEM

 **WARNING**

Failure to check or maintain proper operation of the throttle system can result in an accident and lead to serious injury or death if the throttle pedal sticks during operation.

Always check the pedal for free movement and return before starting the engine and occasionally during operation. Never start or operate this vehicle if it has a sticking or improperly operating throttle pedal. Immediately contact your dealer for service if throttle problems arise.

THROTTLE FREEPLAY

If the throttle pedal has excessive play due to cable stretch or maladjustment, it will cause a delay in throttle response, especially at low engine speed. The throttle may also not open fully. If the throttle pedal has no freeplay, the throttle may be hard to control, and the idle speed may be erratic.

Check the throttle pedal freeplay at the intervals outlined in the Periodic Maintenance Chart. Adjust the freeplay if necessary.

THROTTLE FREEPLAY INSPECTION

1. Apply the brakes. Engage the park brake. Shift the transmission to neutral.
2. Remove grass, leaves, foreign matter, and other flammable material or debris from the throttle linkage and components.
3. Start the engine. Allow it to warm up thoroughly.
4. Measure the distance the throttle pedal moves before the engine begins to pick up speed. Freeplay should be 1.6-3.2 mm (1/16 to 1/8 inches).

IDLE RPM

Idle RPM is preset by the manufacturer. If the engine idle speed is not satisfactory, please see your POLARIS dealer for adjustment.

THROTTLE CABLE ADJUSTMENT

CABLE ADJUSTMENT

1. Ensure that the throttle cable is properly routed and retained to the unit.

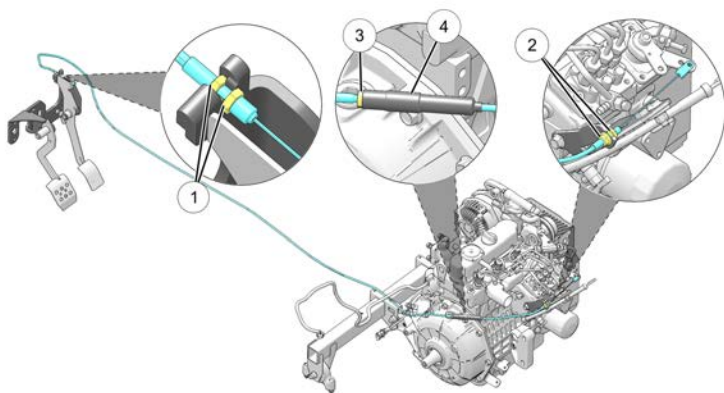

2. On the pedal side, tighten jam nuts ①.

TORQUE

Throttle Cable Jam Nut (pedal side)
5 Nm (43 in-lbs)

3. On the engine side, tighten jam nuts ②.

TORQUE

Throttle Cable Jam Nut (engine side)
13 Nm (10 ft-lbs)

4. Slide back the protective cover to expose the jam nut ③ and adjuster screw ④.
5. Loosen the jam nut and turn the adjuster screw until the throttle lever on the engine moves.
6. Loosen the adjuster back so there is no tension in the cable.

- Once properly adjusted, tighten the jam nut against the adjuster and re-install the protective sleeve.
- Start the engine and allow it to warm up thoroughly. Measure the distance the throttle pedal moves before the engine begins to pick up speed. Freeplay should be 1.6-3.2 mm (1/16 of an inch to 1/8 of an inch).

THROTTLE PEDAL ADJUSTMENT

NOTICE

It is ideal to adjust the throttle pedal with the help of an assistant.

- Loosen the adjustment screw ① and jam nut ②.

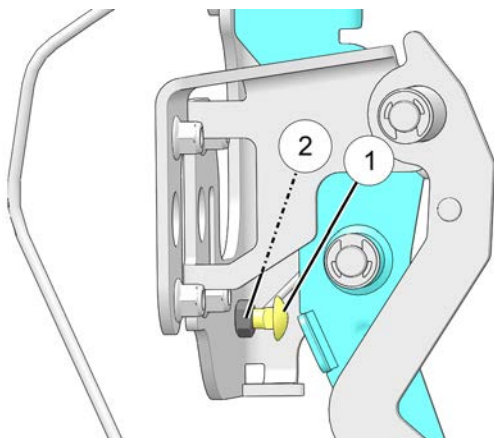

- With the vehicle off and in park, have the assistant fully depress and hold down the throttle pedal.
- The person on the engine side should manually press the lever on the engine to ensure that full travel is being achieved.
- Release the pedal and engine lever and adjust the pedal adjustment screw out 1/2 turn at a time and continue this process until full travel of the engine lever is **NOT** obtained.

MAINTENANCE

5. Slowly adjust the pedal adjuster in a 1/4 turn at a tie until the full engine throttle **IS** obtained. Once proper adjustment is obtained, tighten jam nut in place to hold the adjustment position.

TORQUE

Throttle Pedal Adjuster Jam Nut
19 Nm (14 ft-lbs)

6. With the unit in park, start the unit. Ensure the engine idle is still within range of **1200 +/- 100 RPM**. Fully depress the throttle pedal and ensure that the engine RPM gets to **3850 +/- 50 RPM**.



DO NOT HOLD hold the unit wide open for more than 10 seconds.

BRAKES

 CAUTION

Brake components get hot with prolonged use and can cause burns. Wear protective gloves when inspecting the brakes.

The front and rear brakes are hydraulic disc type brakes. Press down on the brake pedal to engage the brakes.

BRAKE FLUID

Inspect the brake system routinely. Inspect the level of the brake fluid before each operation.

 WARNING

After opening a bottle of brake fluid, always discard any unused portion. Never store or use a partial bottle. Brake fluid is hygroscopic, meaning it rapidly absorbs moisture from the air. The moisture causes the boiling temperature of the brake fluid to drop, which can lead to early brake fade and the possibility of accident or severe injury.

Change the brake fluid every two years and any time the fluid becomes contaminated, the fluid level is below the minimum, or if the type and brand of the fluid in the reservoir are unknown.

1. Position the vehicle on a level surface.
2. View the brake fluid level at the reservoir in the driver's side wheel well. The level should be between the upper (MAX) and lower (MIN) level lines.
3. If the fluid level is lower than the upper level line, open the hood and add brake fluid to the upper (MAX) line.
4. Apply the brake forcefully for a few seconds and check for fluid leakage around the fittings.

MAINTENANCE

BRAKE INSPECTION

WARNING

Do not apply WD-40® or any petroleum product to brake discs. These types of products are flammable and may also reduce the friction between the brake pad and caliper.

CAUTION

Brake components get hot with prolonged use and can cause burns. Wear protective gloves when inspecting the brakes.

1. Check the brake system for fluid leaks.
2. Check the brake pedal for excessive travel or a spongy feel.
3. Check the friction pads for wear, damage and looseness.
4. Check brake discs for signs of cracks, excessive corrosion, warping or other damage. Clean any grease using an approved brake cleaner or alcohol.
5. Inspect the brake disc spline and pad wear surface  for excessive wear. Change pads when worn to 0.762 mm (0.030").

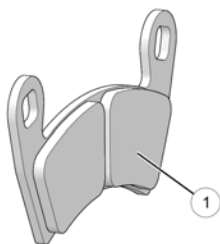

PARKING BRAKE CABLE FREEPLAY ADJUSTMENT

1. Inspect and perform any needed service on the brake pads before adjusting parking brake cable freeplay.
2. Make sure the parking brake is NOT set (the lever should be in the DOWN position).
3. Pull the brake cable back to inspect freeplay between the cable end and the caliper bracket. Freeplay should be 1/16" - 1/8" (1.5-3 mm).
4. To adjust freeplay, loosen the jam nut. Turn the in-line adjuster nut outward to decrease freeplay. Turn the adjuster nut inward to increase freeplay.
5. Tighten the jam nut against the adjuster nut.

STEERING WHEEL INSPECTION

Check the steering wheel for specified freeplay and smooth operation at the intervals outlined in the Periodic Maintenance Chart section.

1. Position the vehicle on level ground.
2. Lightly turn the steering wheel left and right.
3. There should be 0.8-1.0 in (20-25 mm) of freeplay.
4. If there is excessive freeplay or strange noises, or the steering feels rough or “catchy,” have the steering system inspected by an authorized dealer.

SHIFT CABLE / LINKAGE INSPECTION

Ensure that shift cable/linkage is clean, free of debris, operation is smooth and cable boot is not damaged. If operation is not smooth or if the cable boot is damaged or torn, contact an authorized dealer for service.

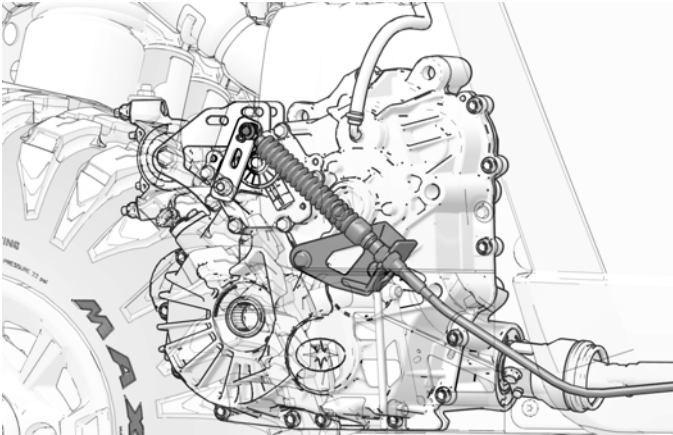

FRONT SUSPENSION ADJUSTMENT

The front suspension can be adjusted to provide a stiffer suspension, if necessary.

1. Remove the top shock mounting bolts from the inside mounting positions ①.
2. Reposition the shocks to the outside mounting holes ②.
3. Reinstall the shock mounting bolts. Torque to 40 ft-lbs (54.2 Nm).

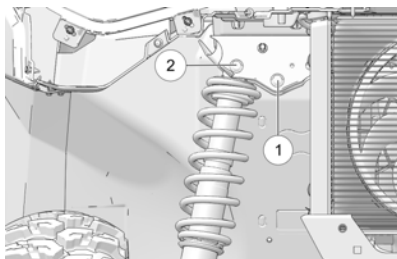

SPRING ADJUSTMENT

Adjust the front and rear shock absorber springs by rotating the adjustment cam either clockwise or counter-clockwise to increase or decrease spring tension.

- ① Stiffest adjustment setting
- ② Softest adjustment setting

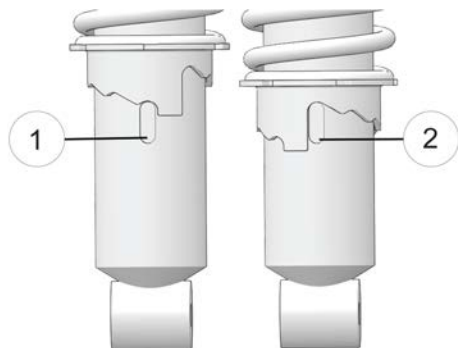

Always heed the following rules if you make adjustments to this suspension.

- Always return the suspension to the lowest (softest) setting after the load is removed from the vehicle. The increased suspension height will negatively impact vehicle stability when operating without a load.
- Always apply the same adjustment setting to both sides of the vehicle.

TIRES

 **WARNING**

Operating your vehicle with worn tires will increase the possibility of skidding, loss of control and an accident, which could result in serious injury or death. Always replace tires when the tread depth measures 3 mm (1/8") or less.

 **WARNING**

Improper tire inflation or the use of non-standard size or type of tires may adversely affect vehicle handling, which could result in vehicle damage or personal injury. Always maintain proper tire pressure. Always use POLARIS approved size and type of tires for this vehicle when replacing tires.

 **WARNING**



Tires age, even if they have not been used or have only been used occasionally. Cracking of the tread and sidewall rubber, sometimes accompanied by carcass deformation, is an evidence of aging. Old and aged tires must be checked and inspected by tire specialists to ascertain their suitability for further use.

TIRE TREAD DEPTH

Always replace tires when tread depth is worn to 1/8 in (3 mm) or less.

AXLE AND WHEEL NUT TORQUE SPECIFICATIONS

Inspect the following items occasionally for tightness, and if they've been loosened for maintenance service. Do not lubricate the stud or the lug nut.

<p>Lug Nut (Aluminum Wheels)</p> 	<p>Front and Rear</p>	<p>163 N·m (120 ft-lbs.)</p>
<p>2-Piece Flange Nut (Steel Wheels)</p> 	<p>Front and Rear</p>	<p>81 N·m (60 ft-lbs.)</p>

MAINTENANCE

Spindle Nut	Front	245 N·m (181 ft. lbs.)
Hub Retaining Nut	Rear	245 N·m (181 ft. lbs.)

WHEEL REMOVAL

1. Position the vehicle on a level surface.
2. Place the transmission in PARK and apply the park brake. Stop the engine.
3. Loosen the wheel nuts slightly.
4. Elevate the side of the vehicle by placing a suitable stand under the frame.
5. Remove the wheel nuts and washers. Remove the wheel.

WHEEL INSTALLATION

WARNING

Improperly installed wheels can adversely affect tire wear and vehicle handling, which can result in serious injury or death. Always ensure that all nuts are torqued to specification. Do not service axle nuts that have a cotter pin installed. Your dealer can assist.

1. Place the transmission in PARK.
2. Place the wheel on the hub with the valve stem toward the outside and rotation arrows on the tire pointing toward forward rotation.
3. Attach the wheel nuts and finger-tighten.
4. Carefully lower the vehicle to the ground.
5. Torque the wheel nuts to specification.

POWER STEERING UNIT

Frequently clean the areas around and on the power steering unit to allow proper cooling. Clean these areas ③ thoroughly.

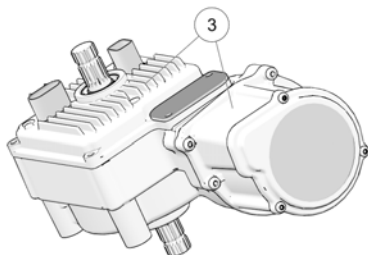

LED LIGHTS (DELUXE MODELS)

LIGHTS

Poor lighting can result in reduced visibility when driving. Headlight and taillight lenses become dirty during normal operation. Clean lights frequently and replace failed (or failing) lights promptly. Do not operate this vehicle at night or in low light conditions until the headlight is replaced. Always make sure lights are adjusted properly for best visibility.

The vehicle is equipped with integrated LED lights. In the event of a failure, the entire assembly^① must be replaced.

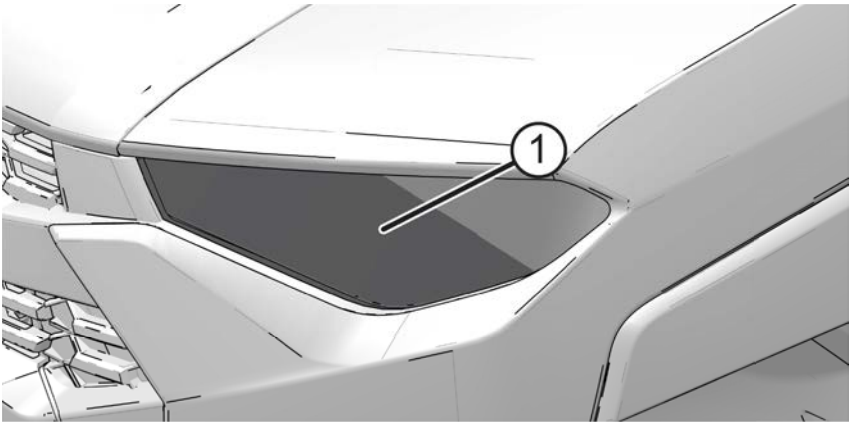

LIGHTS

Poor lighting can result in reduced visibility when driving. Headlight and taillight lenses become dirty during normal operation. Clean lights frequently and replace burned out lamps promptly. Do not operate this vehicle at night or in low light conditions until the headlight is replaced. Always make sure lights are adjusted properly for best visibility.

When servicing a halogen lamp, don't touch the lamp with bare fingers. Oil from your skin leaves a residue, causing a hot spot that will shorten the life of the lamp.

HEADLIGHT BULB REPLACEMENT

- ① Indicator Bulb
- ② Position Bulb
- ③ High/Low Bulb

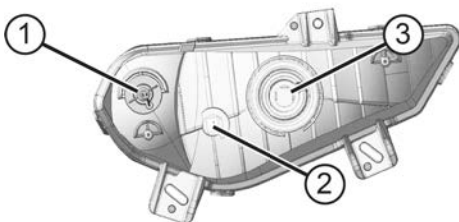

POSITION BULB AND INDICATOR BULB REPLACEMENT

1. Remove the hood from the front cab.
2. Locate the bulb on the back side of the headlight housing.
3. Disconnect the harness from the bulb. Be sure to pull on the connector, not on the wiring.
4. Turn the bulb counterclockwise and remove it from the headlight housing.
5. Install the new bulb into the housing and rotate it clockwise 90° to lock it in place.

NOTE
Make sure the tab on the bulb locates properly in the housing.

6. Install the harness onto the new headlight bulb and install the hood.

HIGH/LOW BULB REPLACEMENT

1. Remove the hood from the front cab.
2. Locate the High/Low bulb on the back side of the headlight housing.

3. Disconnect the harness from the bulb. Be sure to pull on the connector, not on the wiring.
4. Remove the rubber bulb cover, release the bulb protection spring ① and remove the bulb from the headlight housing.



5. Install the new bulb into the housing.

NOTE
Make sure the tab on the bulb locates properly in the housing.

6. Make sure the bulb catches on the protection spring. Reinstall the rubber bulb cover.
7. Install the harness onto the new High/Low bulb and install the hood.

MAINTENANCE

HEADLIGHT ADJUSTMENT

The headlight beams are adjustable.

1. Place the vehicle on a level surface with the headlight approximately 25 ft. (7.6 m) ③ from a wall.

NOTE

Ensure the tire pressure for all four tires are at recommended levels.

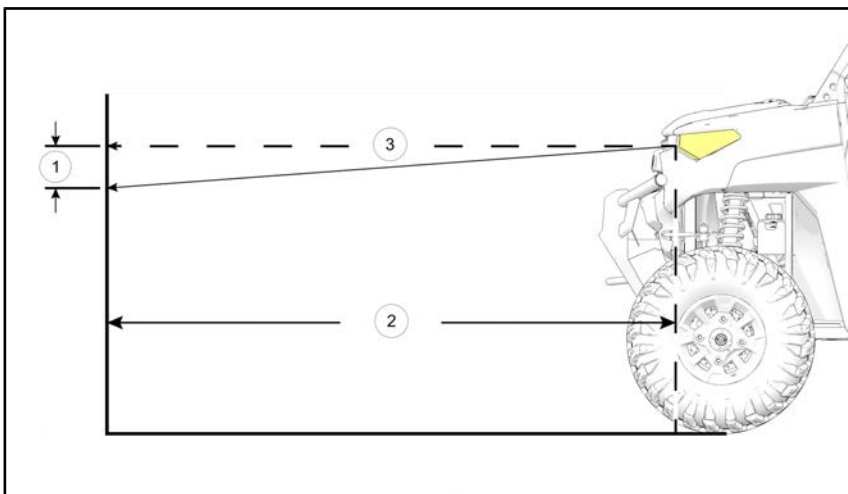

ITEM	DESCRIPTION
①	Measure Distance = 7.5 in (19.0 cm)
②	Measure Distance = 25 ft (7.6 m)
③	Headlight Center of Bulb

2. Measure the distance from the floor to the center of the headlight and make a mark on the wall at the same height.
3. With the machine in PARK, start the engine and turn the headlight switch to the LOW position.

- The most intense part of the LOW beam headlight beam should be aimed 7.5 in. (19.0 cm) ① below the mark placed on the wall.

NOTICE

Rider weight must be included in the seat while performing this procedure.

- Adjust the beam to the desired position by loosening or tightening the adjustment screws and moving the lamp to the appropriate height.
- Tighten Headlight adjustment screws ① to adjust the beam to desired position. Repeat the procedure to adjust the other headlight.

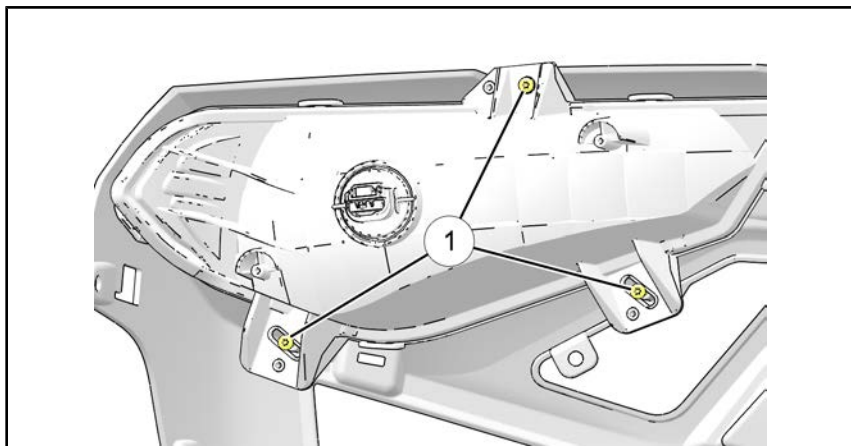

WARNING

Due to the nature of light utility vehicles and where they are operated, headlight lenses become dirty. Frequently washing is necessary to maintain lighting quality. Riding with poor lighting can result in severe injury or death.

MAINTENANCE

BRAKE LIGHTS

When the brake pedal is depressed, the brake light comes on. Check the brake light before each ride.

To check the brake lights, do the following:

1. Turn the key to the ON position.
2. Depress the brake pedal. The brake light should come on after about 0.4 in (10 mm) of pedal travel. If the light doesn't come on, check the electrical connector to the brake lamp.

<i>NOTICE</i>
There are no serviceable components in the brake light assembly.

FUSES

If the engine stops or will not start, or if you experience other electrical failures, a fuse may need replacement. Locate and correct any short circuits that may have caused the blown fuse, then replace the fuse. The fuse box ① is located under the passenger seat. Spare fuses are provided in the fuse box. If you suspect that a fuse or relay may not be working properly, your dealer can assist.

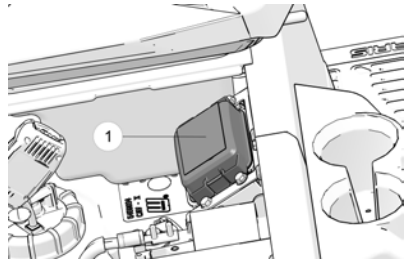

FUSE SIZE	FEATURE SUPPORTED
10A	Key Switch
10A	EFI
15A	Drive
30A	EPS
10A	Alternator
20A	Fan CB
20A	Access
7.5A	Winch
5A	Display
15A	Headlight
10A	Flasher
10A	Trailer
5A	Brake Light
30A	Start
5A	Rear Fog
10A	Trickle Charge
10A	Tractor

BATTERY

WARNING

Battery electrolyte is poisonous. It contains sulfuric acid. Serious burns can result from contact with skin, eyes or clothing.

Antidote:

External: Flush with water.

Internal: Drink large quantities of water or milk. Follow with milk of magnesia, beaten egg, or vegetable oil. Call physician immediately.

Eyes: Flush with water for 15 minutes and get prompt medical attention.

Batteries produce explosive gases. Keep sparks, flame, cigarettes, etc. away. Ventilate when charging or using in an enclosed space. Always shield eyes when working near batteries. **KEEP OUT OF REACH OF CHILDREN.**

Your vehicle may have either a sealed battery, which requires little maintenance, or a conventional battery. A sealed battery can be identified by its flat covers on the top of the battery. A conventional battery has six filler caps on the top of the battery.

Always keep battery terminals and connections free of corrosion. If cleaning is necessary, remove the corrosion with a stiff wire brush. Wash with a solution of one tablespoon baking soda and one cup water. Rinse well with tap water and dry off with clean shop towels. Coat the terminals with dielectric grease or petroleum jelly. Be careful not to allow cleaning solution or tap water into a conventional battery.

WARNING

Improperly connecting or disconnecting battery cables can result in an explosion and cause serious injury or death. When removing the battery, always disconnect the negative (black) cable first. When reinstalling the battery, always connect the negative (black) cable last.

BATTERY FLUID (CONVENTIONAL BATTERY)

A poorly maintained battery will deteriorate rapidly. Check the battery fluid level often. Maintain the fluid level between the upper ① and lower level ② marks.

Add only distilled water. Tap water contains minerals that are harmful to a battery.

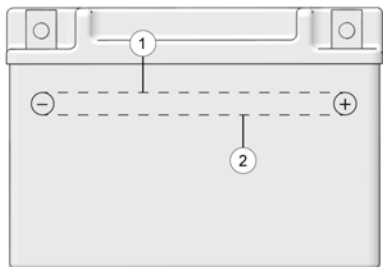

BATTERY REMOVAL

 **WARNING**

Improperly connecting or disconnecting battery cables can result in an explosion and cause serious injury or death. When removing the battery, always disconnect the negative (black) cable first. When reinstalling the battery, always connect the negative (black) cable last.

To remove the battery, do the following:

1. Remove the storage bin under the passenger seat to access the battery.
2. On conventional batteries, remove the battery vent tube.
3. Disconnect the black (-) battery cable first. Disconnect the red (+) battery cable last.
4. Remove the battery hold-down strap.
5. Lift the battery out of the vehicle. Be careful not to tip a conventional battery sideways, which could spill electrolyte.

NOTICE

If electrolyte spills, immediately wash it off with a solution of one tablespoon baking soda and one cup water to prevent damage to the vehicle.

MAINTENANCE

BATTERY INSTALLATION

Using a new battery that has not been fully charged can damage the battery and result in a shorter life. It can also hinder vehicle performance. Follow instructions in the Battery Charging (Conventional Battery) section before installing the battery.

An optional extreme use battery may be available for your model. If the performance of the factory-installed battery is inadequate due to operation in extreme cold or due to extended use of multiple electrical accessories, your dealer can assist. Your dealer can provide any installation procedures that may differ for an extreme use battery.

1. Ensure that the battery is fully charged.
2. Place the battery in the battery holder.
3. On conventional batteries, install the battery vent tube (sealed batteries do not have a vent tube). The vent tube must be free of obstructions and securely installed. Route the tube away from the frame and vehicle body to prevent contact with electrolyte.

 **WARNING**

Battery gases could accumulate in an improperly installed vent tube and cause an explosion, resulting in serious injury or death. Always ensure that the vent tube is free of obstructions and is securely installed as recommended.

4. Coat the terminals with dielectric grease or petroleum jelly.
5. Connect and tighten the red (positive) cable first.
6. Connect and tighten the black (negative) cable last.
7. Install the battery hold-down strap and tighten the screws.
8. Verify that cables are properly routed.
9. Reinstall the seat.

BATTERY STORAGE

Whenever the vehicle is not used for a period of three months or more, remove the battery from the vehicle, ensure that it's fully charged, and store it out of the sun in a cool, dry place. Check battery voltage each month during storage and recharge as needed to maintain a full charge.

TIP

Battery charge can be maintained by using a Polaris battery trickle charger or by charging about once a month to make up for normal self discharge. The battery trickle charger can be left connected during the storage period, and will automatically charge the battery if the voltage drops below a predetermined point.

BATTERY CHARGING (CONVENTIONAL BATTERY)

1. Remove the battery from the vehicle to prevent damage from leaking or spilled electrolyte during charging.
2. Charge the battery with a charging output no larger than 1/10 of the battery's amp/hr rating. Charge as needed to raise the specific gravity to 1.270 or greater.
3. Reinstall the battery. Make sure the positive terminal is toward the front of the vehicle.

MAINTENANCE

BATTERY CHARGING (SEALED BATTERY)

The following battery charging instructions apply only to the installation of a sealed battery. Read all instructions before proceeding with the installation of this battery.

The sealed battery is already filled with electrolyte and has been sealed and fully charged at the factory. Never pry the sealing strip off or add any other fluid to this battery.

The single most important thing about maintaining a sealed battery is to keep it fully charged. Since the battery is sealed and the sealing strip cannot be removed, you must use a voltmeter or multimeter to measure DC voltage.

WARNING

An overheated battery may explode, causing severe injury or death. Always watch charging times carefully. Stop charging if the battery becomes very warm to the touch. Allow it to cool before resuming charging.

For a refresh charge, follow all instructions carefully.

1. Check the battery voltage with a voltmeter or multimeter. A fully charged battery will register 12.8 V or higher.
2. If the voltage is less than 12.8 volts, recharge the battery at 1.2 amps or less until battery voltage is 12.8 or greater.

TIP

When using an automatic charger, refer to the charger manufacturer's instructions for recharging. When using a constant current charger, use the guidelines below for recharging.

Always verify battery condition before and 1-2 hours after the end of charging.

STATE OF CHARGE	VOLTAGE	ACTION	CHARGE TIME*
100%	12.8-13.0 volts	None, check at 3 mos. from date of manufacture	None required
75%-100%	12.5-12.8 volts	May need slight charge, if no charge given, check in 3 months	3-6 hours
50%-75%	12.0-12.5 volts	Needs charge	5-11 hours

STATE OF CHARGE	VOLTAGE	ACTION	CHARGE TIME*
25%-50%	11.5-12.0 volts	Needs charge	At least 13 hours, verify state of charge
0%-25%	11.5 volts or less	Needs charge with desulfating charger	At least 20 hours

*(Using constant current charger @ standard amps specified on top of battery)

CLEANING AND STORAGE

WASHING THE VEHICLE

Keeping your POLARIS vehicle clean will not only improve its appearance but it can also extend the life of various components.

NOTICE

High water pressure may damage components. POLARIS recommends washing the vehicle by hand or with a garden hose, using mild soap.

NOTICE

Certain products, including insect repellents and chemicals, will damage plastic surfaces. Do not allow these types of products to contact the vehicle.

The best and safest way to clean your POLARIS vehicle is with a garden hose and a pail of mild soap and water.

1. Use a professional-type washing cloth, cleaning the upper body first and the lower parts last.
2. Rinse with clean water frequently.
3. Dry surfaces with a chamois to prevent water spots.

MAINTENANCE

WASHING TIPS

- Avoid the use of harsh cleaners, which can scratch the finish.
- Do not use a power washer to clean the vehicle.
- Do not use medium to heavy duty compounds on the finish.
- Always use clean cloths and pads for cleaning and polishing. Old or reused cloths and pads may contain dirt particles that will scratch the finish.
- Grease all zerk fittings immediately after washing. Allow the engine to run for a while to evaporate any water that may have entered the engine or exhaust system.

If a high pressure water system is used for cleaning (not recommended), exercise extreme caution. The water may damage components and could remove paint and labels. Avoid directing the water stream at the following items:

- Wheel bearings
- Radiator
- Transmission seals
- Brakes
- Door seals (if equipped)
- Cab and body panels
- Labels and decals
- Electrical components and wiring
- Air intake components
- Window seals (if equipped)

If an informational or graphic label becomes illegible or comes off, contact your POLARIS dealer, or other qualified person, to purchase a replacement. Replacement safety labels are provided by POLARIS at no charge.

POLISHING THE VEHICLE

POLARIS recommends the use of common household aerosol furniture polish for polishing the finish on your POLARIS vehicle. Follow the instructions on the container.

POLISHING TIPS

- Avoid the use of automotive products, some of which can scratch the finish of your vehicle.
- Always use clean cloths and pads for cleaning and polishing. Old or reused cloths and pads may contain dirt particles that will scratch the finish.

CHROME WHEEL CARE (IF EQUIPPED)

Proper maintenance will protect chrome wheels from corrosion, preserve wheel life and ensure a “like new” appearance for many years. Chrome wheels exposed to road salt (or salt in the air in coastal areas) are more susceptible to corrosion if not properly cleaned. Clean chrome wheels more often if they’re exposed to salt or other corrosive elements.

1. Wash chrome wheels frequently. Use a mild detergent. Never use abrasive cleaners on plated or painted surfaces.
2. Rinse well with clear water. Soap, detergents, salt, dirt, mud and other elements can cause corrosion.
3. Polish the clean chrome wheels periodically. Use an automotive grade chrome polish.
4. Routinely and liberally apply a weather resistant wax to each polished chrome wheel. Choose a product suitable for chrome finishes. Read and follow the product labels and instructions.

REMOVING CORROSION

If light rust is found on the chrome finish, use steel wool (#0000-OTT grade) to remove it. Gently rub the affected areas with the steel wool until the corrosion has been removed. Clean and polish the wheel as outlined above.

STORAGE TIPS

NOTICE

Starting the engine during the storage period will disturb the protective film created by fogging and damage could occur. Never start the engine during the storage period.

CLEAN THE EXTERIOR

Make any necessary repairs and clean the vehicle as recommended.

STABILIZE THE FUEL

1. Fill the fuel tank.
2. Add POLARIS Carbon Clean Fuel Treatment or POLARIS Fuel Stabilizer or equivalent fuel treatments or stabilizers. Follow the instructions on the container for the recommended amount. Carbon Clean removes water from fuel systems, stabilizes fuel and removes carbon deposits from pistons, rings, valves and exhaust systems.
3. Allow the engine to run for 15-20 minutes to allow the stabilizer to disperse through the entire fuel delivery system.

OIL AND FILTER

Change the oil and filter. See the Engine Oil section.

AIR FILTER / AIR BOX

Replace the air filter. See Maintenance Chapter. Clean the air box.

FLUID LEVELS

Inspect the fluid levels. Add or change fluids as recommended in the Periodic Maintenance Chart.

- Demand drive fluid (front gearcase)
- Rear gearcase fluid (if equipped)
- Transmission fluid
- Brake fluid (change every two years and any time the fluid looks dark or contaminated)
- Coolant (test strength/fill)

INSPECT AND LUBRICATE

Inspect all cables and lubricate all areas of the vehicle as recommended in the Periodic Maintenance Chart.

STORAGE AREA / COVERS

Be sure the storage area is well ventilated. Cover the vehicle with a genuine POLARIS cover. Do not use plastic or coated materials. They do not allow enough ventilation to prevent condensation, and may promote corrosion and oxidation.

REMOVAL FROM STORAGE

 **WARNING**

Engine exhaust contains poisonous carbon monoxide and can cause loss of consciousness or death. Never run an engine in an enclosed area.

1. Check the battery electrolyte level and charge the battery if necessary. Install it in the vehicle. Make sure the battery vent hose is routed properly and that it's not pinched or restricted in any way.
2. Make sure spark plugs are tight.
3. Fill the fuel tank with fuel.
4. Check all the points listed in the Daily Pre-Ride Inspection. *Tightness of the bolts, nuts and other fasteners should be checked by an authorized dealer or other qualified service facility.*
5. Lubricate at the intervals outlined in the Periodic Maintenance Chart.

SPECIFICATIONS

RANGER DIESEL MD / ISRAEL

	RANGER DIESEL MD / ISRAEL
Gross Vehicle Weight (includes weight of operator, passenger, cargo, accessories)	1356 kg (2989 lbs.)
Dry Weight	775 kg (1709 lbs.)
Fuel Capacity	43.5 l (11.5 gal)
Engine Oil Capacity	3.7 l (0.98 gal)
Coolant Capacity	5.5 l (5.8 qts.)
Overall Length	305 cm (120 in.)
Overall Width	159 cm (62.5 in.)
Overall Height	195 cm (77 in.)
Wheelbase	206 cm (81 in)
Cargo Box Dimensions (Inside)	93 x 137 x 29 cm (36.5 x 54 x 11.5 in.)
Ground Clearance	33 cm (13 in)
Min. Turning Radius	401 cm (158 in.)
Maximum Braked Trailer Mass	1000 kg (2205 lbs.)
Maximum Unbraked Trailer Mass	730 kg (1609 lbs.)
Max. Cargo Box Load	412 kg (908 lbs.)
Engine	Kubota® liquid-cooled 3 Cylinder Diesel
Displacement	898 cc
Bore x Stroke (mm)	72 mm x 73.6 mm
Alternator Output	1715 W @ 3000 RPM

SPECIFICATIONS

	RANGER DIESEL MD / ISRAEL
Compression Ratio	24:1
Starting System	Electric
Fuel System	Mechanical Fuel Injection
Lubrication System	Wet Sump
Cooling	Liquid
Front Suspension	Dual A-Arm, IRS 27.94 cm (11.0 in) Travel
Rear Suspension	Dual A-Arm 27.94 cm (11.0 in) Travel
Driving System Type	PVT
Shift Type	Single Lever (H/L/N/R/P)
Gear Reduction - Low	Front 9.65:1 / Rear 28.84:1
Gear Reduction - Reverse	Front 8.64:1 / Rear 25.83:1
Gear Reduction - High	Front 3.92:1 / Rear 11.72:1
Drive Ratio - Front	3.23:1
Tire Size - Front	MD models : 27 x 9-14 ProArmour X-T Israel models: 26 x 9-12 Polaris PXT
Tire Size - Rear	MD models : 27 x 11-14 ProArmour X-T Israel models: 26 x 11-12 Polaris PXT
Tire Pressure - Front	69 kPa (10 psi)
Tire Pressure - Rear	96.5 kPa (14 psi)
Tire Speed / Load Index - Front	73J
Tire Speed / Load Index - Rear	85J
Brakes, Front/Rear	Foot Activated, 4 wheel hydraulic disc
Headlights	H4 Bulb 12V P43T 60/55W

SPECIFICATIONS

RANGER DIESEL MD / ISRAEL	
Front Position Light	W5W T10 12V/5W
Indicator Light Bulb	PY21W/Yellow
Taillights	10 L.E.D. (.28W)
Brake Light	10 L.E.D. (3.1W)
Noise and Vibration Specifications*	
A - Weighted Sound Pressure at Rider's Ear	79.6 dB(A)
C- Weighted Sound Pressure Level	95.1 dB(C)
A - Weighted Sound Power Level	N / A
Weighted Hand-Arm Vibration Level (m/s ²)	4.12
Weighted Seat Vibration Level (m/s ²)	0.111
<p>*Uncertainty of noise measurements: 3 dB *Uncertainty for vibration measurements: N/A m/s²</p> <p>Noise emission values are determined according to Annex F of EN 16990:2020. Vibration values are determined according to Annex G of EN 16990:2020. The measured noise and vibration values are for stationary vehicles, noise and vibration values during operation/traveling in foreseeable normal use of the vehicles are not significantly different.</p>	

CARBON DIOXIDE EMISSIONS

CO₂ Emissions: 1047.4 g/kWh*

*This CO₂ measurement results from testing over a fixed test cycle under laboratory conditions a(n) (parent) engine representative of the engine type (engine family) and shall not imply or express any guarantee of the performance of a particular engine.

SPECIFICATIONS

RANGER DIESEL TRACTOR

	RANGER DIESEL TRACTOR
Gross Vehicle Weight (includes weight of operator, passenger, cargo, accessories)	1356 kg (2989 lbs.)
Dry Weight	775 kg (1709 lbs.)
Fuel Capacity	43.5 l (46 gal)
Engine Oil Capacity	3.7 l (0.98 gal)
Coolant Capacity	5.5 l (5.8 qts.)
Overall Length	305 cm (120 in.)
Overall Width	159 cm (62.5 in.)
Overall Height	195 cm (77 in.)
Wheelbase	206 cm (81 in)
Cargo Box Dimensions (Inside)	93 x 137 x 29 cm (36.5 x 54 x 11.5 in.)
Ground Clearance	33 cm (13 in)
Min. Turning Radius	401 cm (158 in.)
Maximum Braked Trailer Mass	1000 kg (2205 lbs.)
Maximum Unbraked Trailer Mass	730 kg (1609 lbs.)
Max. Cargo Box Load	412 kg (908 lbs.)
Engine	4-Stroke 3 Cylinder Diesel
Displacement	898 cc
Bore x Stroke (mm)	72 mm x 73.6 mm
Alternator Output	1715 W @ 3000 RPM
Compression Ratio	24:1

SPECIFICATIONS

	RANGER DIESEL TRACTOR
Starting System	Electric
Fuel System	Mechanical
Lubrication System	Wet Sump
Cooling	Liquid
Front Suspension	Dual A-Arm, IRS 27.94 cm (11.0 in) Travel
Rear Suspension	Dual A-Arm 27.94 cm (11.0 in) Travel
Driving System Type	PVT
Shift Type	Single Lever (H/L/N/R/P)
Gear Reduction - Low	Front 9.65:1/ Rear 28.84:1
Gear Reduction - Reverse	Front 8.64:1 / Rear 25.83:1
Gear Reduction - High	Front 3.92:1 / Rear 11.72:1
Drive Ratio - Front	3.23:1
Tire Size - Front	27 x 9-14 ProArmour X-T
Tire Size - Rear	27 x 11-14 ProArmour X-T
Tire Pressure - Front	69 kPa (10 psi)
Tire Pressure - Rear	97 kPa (14 psi)
Brakes, Front/Rear	Foot Activated, 4 wheel hydraulic disc
Headlights	H4 Bulb 12V P43T 60/55W Deluxe Models: LED
Front Position Light	W5W T10 12V/5W
Indicator Light Bulb	PY21W/Yellow
Taillights	10 L.E.D. (.28W)

SPECIFICATIONS

	RANGER DIESEL TRACTOR
Brake Light	10 L.E.D. (3.1W)
Noise at Operator's Ear	75,6 dB(A)

SEAT VIBRATION

SEAT VIBRATION			
Driver	Awf	Aws	Ratio
98 kg	2.040	1.046	0.521
59 kg	1.978	0.957	0.484

POLARIS PRODUCTS

QUICK REFERENCE INFORMATION

PART NUMBER	DESCRIPTION
Engine Lubricant	
2878473	15W-40 Diesel Oil — 2 qt (1.9 L)
2879832	5W-40 Synthetic Diesel Oil — 2 qt (1.9 L)
Gearcase / Transmission Lubricants	
2878068	AGL Full Synthetic Gearcase Lubricant & Transmission Fluid — 1 qt (0.95 L)
2878069	AGL Full Synthetic Gearcase Lubricant & Transmission Fluid — 1 gal (3.8 L)
2877922	Demand Drive Fluid — 1 qt (0.95 L)
2877923	Demand Drive Fluid — 1 gal (3.8 L)
2870465	Pump for 1 gal (3.8 L) Jug
Coolant	
2880514	Antifreeze 50/50 Premix — 1 qt (0.95 L)
2880513	Antifreeze 50/50 Premix — 1 gal (3.8 L)
Grease / Specialized Lubricants	
2871312	Grease Gun Kit, All Season Grease
2871322	All Season Grease — 3 fl oz (89 mL)
2871423	All Season Grease — 14 fl oz (414 mL)
2876160	ATV Angle Drive Fluid — 1 qt (0.95 L)
2872276	ATV Angle Drive Fluid — 2.5 gal (9.5 L)
2871460	Premium Starter Grease
2871515	U-Joint Grease — 3 fl oz (89 mL)
2871551	U-Joint Grease — 14 fl oz (414 mL)
2871329	Dielectric Grease (Nyogel®)
Additives / Miscellaneous	
2872189	DOT 4 Brake Fluid
2871956	Loctite® 565 Thread Sealant
2859044	POLARIS Battery Tender Charger

TROUBLESHOOTING

DRIVE BELT WEAR/BURN

POSSIBLE CAUSE	SOLUTION
Driving onto a pickup or tall trailer in high range	Use low gear during loading.
Starting out going up a steep incline	Use low gear.
Driving at low RPM or ground speed 5–11 km/h (3-7 MPH)	Drive at a higher speed or use low gear more frequently.
Insufficient warm-up at low ambient temperatures	Warm the engine at least 5 minutes. With the transmission in neutral, advance the throttle to about 1/8 throttle in short bursts, 5 to 7 times. The belt will become more flexible and prevent belt burning.
Slow/easy clutch engagement	Use the throttle quickly and effectively.
Towing/pushing at low RPM/low ground speed	Use low gear only.
Utility use/plowing	Use low gear only.
Stuck in mud or snow	Shift the transmission to low gear and carefully use fast, aggressive throttle application to engage clutch. WARNING: Excessive throttle may cause loss of control and vehicle rollover.
Climbing over large objects from a stopped position	Shift the transmission to low gear and carefully use fast, brief, aggressive throttle application to engage clutch. WARNING: Excessive throttle may cause loss of control and vehicle rollover.
Belt slippage from water or snow ingestion into the PVT system	Dry out the PVT (see the PVT System Drying section for details). Prevent water from entering the PVT intake duct. See Intake Pre-Filters for more information. Inspect clutch seals for damage if repeated leaking occurs.
Clutch malfunction	Your dealer can assist.
Poor engine performance	Check for fouled plug or foreign material in gas tank or fuel lines. Your POLARIS dealer can assist.
Slippage from failure to warm up belt	Always warm up the belt by operating below 48 km/h for 1.6 km (30 mph for one mile). Warm up for 8 km (5 miles) or more when temperature is below freezing.
Wrong or missing belt	Install the recommended belt.
Improper break-in	Always break in a new belt and/or clutch.

TROUBLESHOOTING

ENGINE DOESN'T TURN OVER

POSSIBLE CAUSE	SOLUTION
Low battery voltage	Recharge the battery to 12.8 VDC
Loose battery connections	Check all connections and tighten
Loose electronic control box connections	Inspect, clean, reinstall connectors

ENGINE TURNS OVER, FAILS TO START

POSSIBLE CAUSE	SOLUTION
Out of fuel	Refuel
Water is present in fuel	Drain the fuel system and refuel
Old or non-recommended fuel	Replace with fresh recommended fuel
Fouled or defective glow plug	Inspect plug and replace if necessary
Water or fuel in crankcase	Your authorized dealer can assist
Low battery voltage	Recharge the battery to 12.8 VDC
Mechanical failure	Your authorized dealer can assist

ENGINE RUNS IRREGULARLY, STALLS OR MISFIRES

POSSIBLE CAUSE	SOLUTION
Loose ignition connections	Check all connections and tighten
Water present in fuel	Replace with new fuel
Low battery voltage	Recharge battery to 12.8 VDC
Incorrect fuel	Replace with recommended fuel
Clogged air filter	Inspect and clean or replace
Clogged intake pre-filter	Inspect and clean (with soapy water) or replace
Other mechanical failure	Your authorized dealer can assist

ENGINE STOPS OR LOSES POWER

POSSIBLE CAUSE	SOLUTION
Out of fuel	Refuel
Kinked or plugged fuel vent line	Inspect and replace
Water is present in fuel	Replace with new fuel
Low battery voltage	Recharge the battery to 12.8 VDC
Incorrect fuel	Replace with fresh recommended fuel
Clogged air filter	Inspect and clean or replace
Clogged intake pre-filter	Inspect and clean (with soapy water) or replace
Other mechanical failure	Your authorized dealer can assist
Overheated engine	Clean radiator screen and core, clean engine exterior. Your dealer can assist.

DIAGNOSTIC DISPLAY CODE DEFINITIONS

DIAGNOSTIC CODES			
COMPONENT	CONDITION	SPN	FMI
Low oil pressure switch fault	CAN message 65390 Timeout error	100	11
	Current below normal or open circuit	100	5
Engine Temperature Sensor	Voltage above normal, or shorted to high source	110	3
	Voltage above normal, or shorted to high source	110	4
System Power (Battery Potential/Power Input)	Data valid but below normal operational range - most severe level	168	1
	Voltage above normal, or shorted to high source	168	3
	Voltage below normal, or shorted to low source	168	4
Gear Sensor Signal	Voltage below normal, or shorted to low source	523	4
Rear Differential Output	Voltage above normal, or shorted to high source	746	3
	Voltage below normal, or shorted to low source	746	4
	Current below normal or open circuit	746	5
Fan Relay Driver Ckt.	Voltage above normal, or shorted to high source	1071	3
	Voltage below normal, or shorted to low source	1071	4
	Current below normal or open circuit	1071	5

TROUBLESHOOTING

DIAGNOSTIC CODES			
COMPONENT	CONDITION	SPN	FMI
Fuel Pump Driver Ckt.	Voltage above normal, or shorted to high source	1347	3
	Voltage below normal, or shorted to low source	1347	4
	Current below normal or open circuit	1347	5
ECU Output Supply Voltage 1	Voltage above normal, or shorted to high source	3597	3
	Voltage below normal, or shorted to low source	3597	4
ECU Output Supply Voltage 3	Voltage above normal, or shorted to high source	3598	3
	Voltage below normal, or shorted to low source	3598	4
All Wheel Drive Control Circuit	Voltage above normal, or shorted to high source	520207	3
	Voltage below normal, or shorted to low source	520207	4
	Current below normal or open circuit	520207	5
Brake failure lamp faults	Voltage above normal, or shorted to high source	520214	3
	Voltage below normal, or shorted to low source	520214	4
	Current below normal or open circuit	520214	5
Glow Plug Relay Driver Circuit	Voltage above normal, or shorted to high source	520272	3
	Voltage below normal, or shorted to low source	520272	4

TROUBLESHOOTING

DIAGNOSTIC CODES			
COMPONENT	CONDITION	SPN	FMI
	Current below normal or open circuit	520272	5
Brake switch (1 or 2 indeterminable)	Data erratic, intermittent or incorrect	520285	2
Engine Oil Pressure Sensor	Data valid but below normal operating range - least severe level	524076	17

WARRANTY

LIMITED WARRANTY

POLARIS Inc., 2100 Highway 55, Medina, MN 55340 (POLARIS) gives a TWO YEAR LIMITED WARRANTY on all components of your POLARIS vehicle against defects in material or workmanship. POLARIS further warrants that the spark arrester in this product will meet the efficiency requirements of USFS standard 5100-1C for at least 1000 hours when subjected to normal use and when maintenance and installation are in accordance with POLARIS recommendations.

This warranty covers parts and labor charges for repair or replacement of defective parts and begins on the date of purchase by the original retail purchaser. This warranty is transferable to another owner during the warranty period through a POLARIS dealer, but any such transfer will not extend the original term of the warranty. The duration of this warranty may vary by international region based upon local laws and regulations.

REGISTRATION

At the time of sale, the Warranty Registration Form must be completed by your dealer and submitted to POLARIS within ten days of purchase. Upon receipt of this registration, POLARIS will record the registration for warranty. No verification of registration will be sent to the purchaser as the copy of the Warranty Registration Form will be your proof of warranty coverage. If you have not signed the original registration and received the customer copy, please contact your dealer immediately. **NO WARRANTY COVERAGE WILL BE ALLOWED UNLESS YOUR VEHICLE IS REGISTERED WITH POLARIS.** Initial dealer preparation and set-up of your vehicle is very important in ensuring trouble-free operation. Purchasing a machine in the crate or without proper dealer set-up will void your warranty coverage.

WARRANTY

WARRANTY COVERAGE AND EXCLUSIONS LIMITATIONS OF WARRANTIES AND REMEDIES

This POLARIS limited warranty excludes any failures that are not caused by a defect in material or workmanship. THIS WARRANTY DOES NOT COVER CLAIMS OF DEFECTIVE DESIGN. This warranty also does not cover acts of God, accidental damage, normal wear and tear, abuse or improper handling. This warranty also does not cover any vehicle, component, or part that has been altered structurally, modified, neglected, improperly maintained or used for racing, competition or purposes other than for which it was designed.

This warranty excludes damages or failures resulting from improper lubrication; improper engine timing; improper fuel; surface imperfections caused by external stress, heat, cold or contamination; operator error or abuse; improper component alignment, tension, adjustment or altitude compensation; snow, water, dirt or other foreign substance ingestion/contamination; improper maintenance; modified components; use of aftermarket or unapproved components, accessories, or attachments; use of unapproved software or calibration; unauthorized repairs; or repairs made after the warranty period expires or by an unauthorized repair center.

This warranty excludes damages or failures caused by abuse, accident, fire, or any other cause other than a defect in materials or workmanship and provides no coverage for consumable components, general wear items, or any parts exposed to friction surfaces, stresses, environmental conditions and/or contamination for which they were not designed or not intended, including but not limited to the following items:

- Wheels and tires
- Suspension components
- Brake components
- Seat components
- Clutches and components
- Steering components
- Batteries
- Light bulbs/Sealed beam lamps
- Filters
- Lubricants
- Bushings
- Finished and unfinished surfaces
- Carburetor/Throttle body components
- Engine components
- Drive belts
- Hydraulic components and fluids
- Circuit breakers/Fuses
- Electronic components
- Spark plugs
- Sealants
- Coolants
- Bearings

LUBRICANTS AND FLUIDS

1. Mixing oil brands or using non-recommended oil may cause engine damage. We recommend the use of POLARIS engine oil.
2. Damage or failure resulting from the use of non-recommended lubricants or fluids is not covered by this warranty.

This warranty provides no coverage for personal loss or expense, including mileage, transportation costs, hotels, meals, shipping or handling fees, product pick-up or delivery, replacement rentals, loss of product use, loss of profits, or loss of vacation or personal time.

THE EXCLUSIVE REMEDY FOR BREACH OF THIS WARRANTY SHALL BE, AT POLARIS' OPTION, REPAIR OR REPLACEMENT OF ANY DEFECTIVE MATERIALS, COMPONENTS, OR PRODUCTS. THE REMEDIES SET FORTH IN THIS WARRANTY ARE THE ONLY REMEDIES AVAILABLE TO ANY PERSON FOR BREACH OF THIS WARRANTY. POLARIS SHALL HAVE NO LIABILITY TO ANY PERSON FOR INCIDENTAL, CONSEQUENTIAL OR SPECIAL DAMAGES OF ANY DESCRIPTION, WHETHER ARISING OUT OF EXPRESS OR IMPLIED WARRANTY OR ANY OTHER CONTRACT, NEGLIGENCE, OR OTHER TORT OR OTHERWISE. THIS EXCLUSION OF CONSEQUENTIAL, INCIDENTAL, AND SPECIAL DAMAGES IS INDEPENDENT FROM AND SHALL SURVIVE ANY FINDING THAT THE EXCLUSIVE REMEDY FAILED OF ITS ESSENTIAL PURPOSE.

THE IMPLIED WARRANTY OF FITNESS FOR A PARTICULAR PURPOSE IS EXCLUDED FROM THIS LIMITED WARRANTY. ALL OTHER IMPLIED WARRANTIES (INCLUDING BUT NOT LIMITED TO THE IMPLIED WARRANTY OF MERCHANTABILITY) ARE LIMITED IN DURATION TO THE ABOVE SIX MONTH WARRANTY PERIOD. POLARIS DISCLAIMS ALL EXPRESS WARRANTIES NOT STATED IN THIS WARRANTY. SOME STATES DO NOT PERMIT THE EXCLUSION OR LIMITATION OF INCIDENTAL OR CONSEQUENTIAL DAMAGES OR ALLOW LIMITATIONS ON THE DURATION OF IMPLIED WARRANTIES, SO THE ABOVE LIMITATIONS MAY NOT APPLY TO YOU IF INCONSISTENT WITH CONTROLLING STATE LAW.

WARRANTY

HOW TO OBTAIN WARRANTY SERVICE

If your vehicle requires warranty service, you must take it to a POLARIS Servicing Dealer. When requesting warranty service you must present your copy of the Warranty Registration Form to the dealer. (THE COST OF TRANSPORTATION TO AND FROM THE DEALER IS YOUR RESPONSIBILITY.) POLARIS suggests that you use your original selling dealer; however, you may use any POLARIS Servicing Dealer to perform warranty service.

IN THE COUNTRY WHERE YOUR PRODUCT WAS PURCHASED:

Warranty or Service Bulletin repairs must be done by an authorized POLARIS dealer, or other qualified person. If you move or are traveling within the country where your product was purchased, Warranty and Service Bulletin repairs may be requested from any authorized POLARIS dealer, or other qualified person, that sells the same line as your product.

OUTSIDE THE COUNTRY WHERE YOUR PRODUCT WAS PURCHASED:

If you are traveling temporarily outside the country where your product was purchased, you should take your product to an authorized POLARIS dealer, or other qualified person. You must show the dealer photo identification from the country of the selling dealer's authorized location as proof of residence. Upon residence verification, the servicing dealer will be authorized to perform the warranty repair.

IF YOU MOVE:

If you move to another country, be sure to contact POLARIS Customer Assistance and the customs department of the destination country before you move. Product importation rules vary considerably from country to country. You may be required to present documentation of your move to POLARIS in order to continue your warranty coverage. You may also be required to obtain documentation from POLARIS in order to register your product in your new country. You should warranty register your product at a local POLARIS dealer in your new country immediately after you move to continue your warranty coverage and to ensure that you receive information and notices regarding your product.

IF YOU PURCHASE FROM A PRIVATE PARTY:

If you purchase a POLARIS product from a private party, to be kept and used outside of the country in which the product was originally purchased, all warranty coverage will be denied. You must nonetheless register your product under your name and address with a local POLARIS dealer in your country to ensure that you receive safety information and notices regarding your product.

EXPORTED PRODUCTS

EXCEPT WHERE SPECIFICALLY REQUIRED BY LAW, THERE IS NO WARRANTY OR SERVICE BULLETIN COVERAGE ON THIS PRODUCT IF IT IS SOLD OUTSIDE THE COUNTRY OF THE SELLING DEALER'S AUTHORIZED LOCATION. This policy does not apply to products that have received authorization for export from POLARIS. Dealers may not give authorization for export. You should consult an authorized dealer to determine this product's warranty or service coverage if you have any questions. This policy does not apply to products registered to government officials or military personnel on assignment outside the country of the selling dealer's authorized location. This policy does not apply to Safety Bulletins.

NOTICE

If your product is registered outside of the country where it was purchased and you have not followed the procedure set above, your product will no longer be eligible for warranty or service bulletin coverage of any kind, other than safety bulletins. Products registered to government officials or military personnel on assignment outside of the country where the product was purchased will continue to be covered by the Limited Warranty.

Please work with your dealer to resolve any warranty issues. Should your dealer require any additional assistance, they will contact the appropriate person at POLARIS.

This warranty gives you specific legal rights, and you may also have other rights which vary from state to state or in different countries. If any of the above terms are void because of federal, state, local law, all other warranty terms will remain in effect.

MAINTENANCE LOG

MAINTENANCE LOG

Use the following chart to record periodic maintenance.

DATE	MILES (KM) OR HOURS	TECHNICIAN	SERVICE PERFORMED / COMMENTS

7-Way Trailer Connector 62

A

Active Descent Control (ADC)
System 88
Adding or Changing Coolant 114
Additional Technical Fuel
Requirements 90
Adjustable Steering Wheel 44
Air Filter / Air Box 158
Air Filter Replacement 125
All Wheel Drive/Rear
Differential System 86
Alternator Belt 129
Auxiliary Outlet 50
Axle and Wheel Nut Torque
Specifications 141

B

Battery 150
Charging 154
Battery Charging (Conventional
Battery) 153
Battery Fluid (Conventional
Battery) 150
Battery Installation 152
Battery Removal 151
Battery Storage 153
Battery Trickle-Charging Outlet 50
Belt Inspection 121
Belt Removal 118
Bio-Diesel Fuels 91
Boarding the Vehicle 78
Brake Fluid 137
Brake Inspection 138
Brake Lights 148
Brake Pedal 51
Brakes 137
Braking 80

C

Cab Nets 58

Carbon Dioxide Emissions 95
Chrome Wheel Care (if
equipped) 157
Clean the Exterior 158
Cold Weather Operation 82
Component Locations 43
Console 44
Cooling System 114

D

Declaration of Conformity 11
Demand Change Oil Change 113
Demand Drive Oil Check 113
Diagnostic Display Code
Definitions 172
Drive Belt
Installation 122
Drive Belt Wear/Burn 169
Dumping the Cargo Box 85

E

Electromagnetic Interference 95
Electronic Power Steering 57
Engine and Drivetrain Break-in 77
Engine Doesn't Turn Over 170
Engine Oil 103
Engine Oil / Filter Change 107
Engine Runs Irregularly, Stalls
or Misfires 170
Engine Stops or Loses Power 171
Engine Turns Over, Fails to
Start 170
Exhaust Emission Control
System 95
Exiting the Vehicle 78
Exported Products 179

F

Fan, Cooling 114
Fluid Levels 158
Forestry Application and Crop
Spraying 34

Front Suspension Adjustment	140
Fuel Alert	39
Fuel Cap	57
Fuel Filter / Water Separator	130
Fuel Recommendations	89
Fuel Safety	89
Fuel Stabilizer	158
Fuses	149

G

Gear Selector	45
Gearcase Specification Chart	111
General Alert - Tractor/Zugmaschine	36
Glow Plug Indicator	48
Greasing Points	101

H

Handling Fuel	93
Hazard Switch	48
Headlight Bulb Replacement	144
Headlights Adjustment	146
Heater Control Panel	49
Hitch Removal / Installation	61
Hitches	60
Hood Latches	59
Hot Exhaust Systems	34
How To Obtain Warranty Service	178

I

Idle RPM	133
Ignition Switch / Light Switch	46
Inspect and Lubricate	158
Instrument Cluster Back Light Color	73
Back Light Level	74
Clock	71
Diagnostic Code	76
Display Area 1	65

Display Area 2	66
Indicator Lamps	64
Options Menu	68
Overview	63
Service Hours	75
Unit Selection Distance	69
Unit Selection Temperature	70
Intake Screens	128
Israel Model Differences	15

J

Jacking Points	103
----------------------	-----

L

Labels

Clutch Cover Alert	38
General Alert	35
Greasing Points Alert	36
Hitch Capacity Alert	35
Hot Exhaust System Warning	37
Hot Liquid Warning	35
Jacking Points Alert	36
Load/Passenger/Tire Pressure Alert	40
Owner's Manual Alert	38
Lightning and Powerlines	34
Lights	143-144
Limited Warranty	175
Low Gear	46
Lubrication Recommendations ...	101

M

Maintenance

Shift Cable / Linkage Inspection	139
Maintenance Log	181
Mud Guard	132

N		Rollover Protective Structure (ROPS)..... 59
Near Field Communication (NFC)..... 13		
Nets 58		
Noise Emission Control System 95		
Non-ionizing Radiation..... 95		
Notice 179		
O		S
Oil / Filter Change..... 107		Safe Operating Guidelines Stopping the Engine and Parking the Vehicle..... 81
Oil and Filter..... 158		Safe Operation Practices Driving in Reverse 81
Oil Check..... 104		Safety
Oil Recommendations 104		Driver and Passenger Qualifications 20
Operator Presence Control System 53		Driving Guidelines 26
ORV Certificate of Pre-Delivery Inspection 12		Owner Requirements 19
Overflow Bottle Coolant Level 116		Prepare Yourself, Passengers, and Cargo for the Ride 24
		Safety Symbols 9
		Seat Adjustments 56
		Seat and Storage
		Compartments 54
		Seat Belts 53
		Beeper 53
		Seat Removal 56
		Shift Alert..... 39
		Signal Words 9
		Spark Arrester 95, 127
		Specifications 161
		Specifications - Tractor 164
		Spring Adjustment 140
		Stabilize the Fuel..... 158
		Starting the Engine 79
		Steering Wheel Inspection..... 139
		Storage 158
		Storage Area 159
		Suspension Adjustment 140
		Switches
		ADC Switch..... 48
		T
		Throttle Cable Adjustment..... 134
		Throttle Freeplay 133
		Throttle Freeplay Inspection..... 133
		Throttle Pedal 51
P		
Park Brake Indicator..... 48		
Park Brake Lever..... 52		
Parking Brake 138		
POLARIS PRODUCTS 167		
POLARIS Variable Transmission (PVT) Drying 124		
POLARIS Variable Transmission System..... 117		
Polishing the Vehicle 156		
Power Steering Unit Cleaning..... 142		
Prepare Vehicle for the Ride 21		
R		
Radiator and Cooling Fan..... 114		
Radiator Coolant Level 115		
Rear Hitch..... 60		
Rear Hitch Certification Label 61		
Registration, Warranty 175		
Removal from Storage..... 159		
Removing Corrosion 157		

Adjustment.....	135
Throttle System.....	133
Tire Tread Depth	141
Tires	141
Tools for Safe Riding	8
Towing a RANGER	33
Towing Loads	83-84
Trailer Hitch Bracket.....	59
Transmission Oil Change	112
Transmission Oil Check	111
Transporting the Vehicle.....	32

U

Underseat Storage Box.....	55
USB Port	50

V

Vehicle Break-in	
Brake System Break-in	77
PVT Break-in (Clutches / Belt)...	78
Vehicle Immersion	124

W

Warning Symbols	9
Washing the Vehicle.....	155
Welcome Page	3
Wheel Installation	142
Wheel Removal.....	142

POLARIS
Think Outside

For your nearest Polaris dealer,
visit www.polaris.com

Polaris Sales Europe Sarl
Place de l'Industrie 2
1180 Rolle
Switzerland

Part No. 9940850 R.01
04.2022

