

2024



For Maintenance and Safety

OWNER'S MANUAL

RANGER XP KINETIC

POLARIS
Think Outside



WARNING

Read, understand, and follow all of the instructions and safety precautions in this manual and on all product labels.

Failure to follow the safety precautions could result in serious injury or death.



WARNING

Operating, servicing, and maintaining a passenger vehicle or off-road vehicle can expose you to chemicals including engine exhaust, carbon monoxide, phthalates, and lead, which are known to the State of California to cause cancer and birth defects or other reproductive harm. To minimize exposure, avoid breathing exhaust, do not idle the engine except as necessary, service your vehicle in a well-ventilated area and wear gloves or wash your hands frequently when servicing your vehicle.

For more information go to www.P65Warnings.ca.gov/passenger-vehicle.



*For videos and more information
about a safe riding experience with
your Polaris vehicle, scan this QR
Code® with your smartphone or visit:
www.polaris.com/en-us/safety*

POLARIS
RANGER[®]

2024 Owner's Manual

RANGER XP KINETIC Premium
RANGER XP KINETIC Ultimate

Unless noted, trademarks are the property of Polaris Industries Inc.

Recreational Off-Highway Vehicle Association® and ROHVA® are registered trademarks of Recreational Off-Highway Vehicle Association. BatteryMINDer® is a registered trademark of VDC Electronics Inc. Loctite® is a registered trademark of Henkel Corporation. NYOGEL® is a registered trademark of Nye Lubricants, Inc. WD-40® is registered to WD-40 Manufacturing Company. QR Code® is a registered trademark of DENSO WAVE INCORPORATED. Apple® and APP STORE® are registered trademarks of Apple Inc. ANSI® is a registered trademark of American National Standards Institute, Inc. Bluetooth® is a registered trademark of Bluetooth Sig, Inc. Google Play® is a registered trademark of Google, LLC. Sandisk® is a registered trademark of SANDISK LLC. exFAT® is a registered trademark of Microsoft Corporation. OSHA® is a registered trademark of the Occupational Safety and Health Administration, U. S. Dept. of Labor. Tread Lightly® is a registered trademark of the United States Department of Agriculture.

Copyright 2024 Polaris Industries Inc. All information contained within this publication is based on the latest product information at the time of publication. Due to constant improvements in the design and quality of production components, some minor discrepancies may result between the actual vehicle and the information presented in this publication. Depictions and/or procedures in this publication are intended for reference use only. No liability can be accepted for omissions or inaccuracies. Any reprinting or reuse of the depictions and/or procedures contained within, whether whole or in part, is expressly prohibited.

The original instructions for this vehicle are in English. Other languages are provided as translations of the original instructions.

Printed in U.S.A.

9941433 R01



Thank you for purchasing a POLARIS vehicle, and welcome to our world-wide family of POLARIS enthusiasts. Be sure to visit us online at www.polaris.com for the latest news, new product introductions, upcoming events, career opportunities and more.

Here at POLARIS we proudly produce an exciting line of utility and recreational products. We believe POLARIS sets a standard of excellence for all utility and recreational vehicles manufactured in the world today. Many years of experience have gone into the engineering, design, and development of your POLARIS vehicle.

For safe and enjoyable operation of your vehicle, be sure to follow the instructions and recommendations in this owner's manual. Your manual contains instructions for minor maintenance, but information about major repairs is outlined in the POLARIS Service Manual and can be performed by a factory certified Master Service Dealer (MSD) technician.

Your POLARIS dealer knows your vehicle best and is interested in your total satisfaction. Your POLARIS dealership can perform all of your service needs during and after the warranty period.

For the most up-to-date owner's manual visit
<https://www.polaris.com/en-us/owners-manuals>.

WELCOME

The following signal words and symbols appear throughout this manual and on your vehicle. Your safety is involved when these words and symbols are used. Become familiar with their meanings before reading the manual.

DANGER

DANGER indicates a hazardous situation which, if not avoided, WILL result in death or serious injury.

WARNING

WARNING indicates a hazardous situation which, if not avoided, COULD result in death or serious injury.

CAUTION

CAUTION indicates a hazardous situation which, if not avoided, COULD result in minor to moderate injury.

NOTICE

NOTICE provides key information by clarifying instructions.

IMPORTANT

IMPORTANT provides key reminders during disassembly, assembly, and inspection of components.

The Prohibition Safety Sign indicates an action NOT to take in order to avoid a hazard.



The Mandatory Action Sign indicates an action that NEEDS to be taken to avoid a hazard.



Introduction	7
Safety	11
Introduction to EV	35
Features and Controls	49
Ride Command Display (if equipped)	75
Operation	89
Maintenance	93
Specifications	121
POLARIS Products	125
Troubleshooting	127
Warranty	135
Maintenance Log	141

INTRODUCTION

TOOLS FOR SAFE RIDING

To safely operate this vehicle, it is important to become familiar with its features, controls, and characteristics. Review all items in the Safety chapter for this vehicle that apply to you:

- Operators
- Riders
- Owners
- Trailering the Vehicle
- Maintaining the Vehicle

Additionally, read the product safety labels on the vehicle and follow all rules and regulations concerning the operation of this vehicle in your area.

Polaris recommends anyone who will be operating this vehicle to take a training course. ROHVA® (Recreational Off-Highway Vehicle Association®) provides both an online safety e-course and a hands-on safety course. To access this training, visit www.rohva.org.

Other sources of safety information include the Polaris Safety Video. The Polaris Help Center also has additional information: <https://ranger.polaris.com/en-us/self-help>

INTRODUCTION

VEHICLE TESTING

This Off-Road Vehicle was subjected to the following tests of the National Standard for Recreational Off-Highway Vehicles, ANSI®/ROHVA® 1-2016:

- Maximum Speed Capability
- Service Brake Performance
- Parking Brake/Mechanism Performance
- Lateral Stability
- Pitch Stability
- Vehicle Handling
- Roll Over Protective Structure (ROPS)
- Occupant Retention System (ORS)
- Sound Level Limits

VEHICLE IDENTIFICATION NUMBERS

Record your vehicle's identification numbers and key number in the spaces provided. Remove the spare key and store it in a safe place. An ignition key can be duplicated only by ordering a Polaris key blank (using your key number) and mating it with one of your existing keys. The ignition switch must be replaced if all keys are lost.

NOTICE

The images below are for reference only. Depending on model, your vehicle may differ slightly.

The VIN can be found stamped on a portion of the left rear frame ①, above the wheel well liner. If equipped, the VIN can be found using the NFC emblem at the front of the vehicle. See page 49 for details.

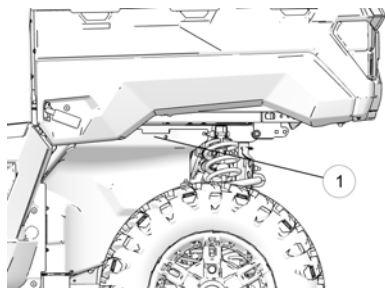

Vehicle Model Number:	
Vehicle Identification Number (VIN):	
Key Number:	
NRMM Reference Number (if applicable):	

SAFETY

OWNER REQUIREMENTS

Improper use, maintenance, or modification of this vehicle can lead to serious injury or death.

Require proper use of your vehicle. Do not allow anyone to operate your vehicle or ride as a passenger unless they are properly instructed and you are sure they are willing to ride responsibly. To prevent unauthorized use, always remove the vehicle key when the vehicle is not in use.



Any modifications or installation of non-Polaris-approved accessories could increase the risk of injury. While you may find aftermarket products similar in design and quality to Polaris accessories, recognize that some aftermarket accessories or modifications are not suitable because of potential safety hazards to you or others. It is never appropriate to install any additional seating.

Check with the manufacturer to determine any potential effect of a modification or accessory on the safe use of your vehicle. You are responsible for injuries related to modifications to the vehicle. Modifications or accessories may:

- Damage machine components - especially modifications that increase speed or power.
- Make the vehicle less stable at higher speeds.
- Add weight, reducing the amount of cargo and total weight you can carry, and raise the vehicle's center of gravity.
- Overload the vehicle's electrical system capacity (see page 121). Blowing a fuse may cause a loss of lights or motor power.
- Reduce the effectiveness of occupant protection systems, including the seatbelts and the Rollover Protective Structure (ROPS).
- Void your warranty.

The vehicle ROPS, when used with the seat belts and doors/nets, provides a structure to help protect occupants. The structure will not protect occupants in all rollovers or accidents.

DRIVER AND PASSENGER QUALIFICATIONS

Make sure operators are 16 or older with a valid driver's license. Just because a teenager has a license does not mean that they will make good judgments about driving and avoid risk taking.

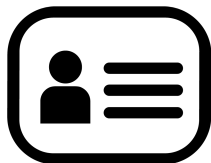

POLARIS recommends that you supervise younger drivers. Set rules and put limits on how, when, and where they are allowed to use this vehicle. For example, young drivers may need to have an adult in the vehicle with them and not be allowed to drive with their friends in the vehicle.

Make sure all riders fit the vehicle. Be sure that the driver and all passengers are able to:

- sit with their backs against their seat,
- adjust the seat belt to fit properly,
- have both feet flat on the floor, and
- have both hands on the steering wheel or on a passenger hand hold.

Do not allow children who need child safety seats or booster seats to ride in the vehicle. The vehicle is not designed to restrain automotive child safety seats.

You are responsible for your passengers. Be sure passengers are seated properly, belted, holding the passenger hand hold, and ready to brace. Unrestrained riders can fall out or be thrown around and from a moving vehicle.

Every person must be properly seated and belted in their own seat. Two people should never be belted into a single seat belt. People belted together can crash into one another in a collision and be seriously injured. Never carry passengers in the cargo bed as they could be thrown against or out of the vehicle or come into contact with moving parts.

Do not let people drive or ride after using alcohol or drugs.

PREPARE VEHICLE FOR THE RIDE

Before starting off, always perform the Pre-Ride Inspection. Failure to inspect and verify that the vehicle is in safe operating condition increases the risk of an accident, which can lead to serious injury or death.



ITEM	REMARK	REFERENCE
Charge Status	Ensure High-Voltage Battery Pack is charged sufficiently	page 37
Brake Fluid	Ensure proper level and condition	page 103
Front and rear suspension	Inspect condition and adjust as necessary	page 105
Steering	Ensure free operation	page 104
Tires	Inspect condition and pressure	page 29 page 106
Wheels/Lug Nuts	Inspect, ensure fastener tightness	page 106
Indicator lights/switches	Ensure proper operation	page 53 page 62
Headlights	Check operation and adjust as needed	page 113
Brake lights/taillights	Check operation	page 113
Seat Belts	Check length of belt for damage, check latches for proper operation	page 58
Vehicle Debris	Remove grass, leaves, and other flammable material or debris.	–
Lock adjustable steering wheel	Do not adjust the steering wheel while the vehicle is moving.	page 56

SAFETY

Improper tire maintenance can lead to loss of control and an accident, which could result in serious injury or death. To reduce your risk of injury:

- Maintain Polaris recommended tire pressure. Check pressure before operating. Even if your vehicle has only been driven a short distance, the tire pressure readings can become higher.
- Make sure tire pressures match the specifications listed in the table below.
- Only use the size and type of tires specified for this vehicle.
- Do not operate your vehicle with worn or damaged tires. See page 106 for details.
- Always follow your tire manufacturer's instructions for maintenance.

MEASUREMENT	SPECIFICATION
Maximum Cargo Box Load	1250 lbs. (567 kg)
Maximum Cargo Load When Trailer Towing	600 lbs. (272 kg)
Tire Pressure in PSI (kPa)	Front - 12 (83) Rear - 14 (97)
Maximum Weight Capacity Includes weight of operator, passenger, cargo, and accessories	1500 lbs (680 kg)

PREPARE YOURSELF, PASSENGERS, AND CARGO FOR THE RIDE

Wear an approved helmet. Riding in this vehicle without wearing an approved helmet increases the risk of serious injury. For example, a helmet reduces your risk of injury from head strikes with the vehicle or other objects even if there is no crash.

Approved helmets in the USA and Canada bear a U.S. Department of Transportation (DOT) label. Approved helmets in Europe, Asia, and Oceania bear the ECE 22.05 label. The ECE mark consists of a circle surrounding the letter E, followed by the distinguishing number of the country which has granted approval. The approval number and serial number will also be displayed on the label.



Use shatterproof goggles or a shatterproof helmet face shield. Such protective eyewear may reduce the risk of foreign material getting in your eyes and help prevent loss of vision.

Polaris recommends wearing approved Personal Protective Equipment (PPE) that have markings indicating they are designed to standards such as:

- VESC 8
- V-8
- Z87.1
- CE



Additional protective clothing and gear that may be appropriate for your riding conditions includes:

- Always wear shoes when operating. Consider wearing sturdy over-the-ankle boots suitable for the terrain you will be riding in.
- Full-finger gloves can protect against wind, sun, cold, and objects. Choose gloves that fit snugly and allow fingers to move freely and grip on the steering wheel or hand holds.
- Consider long sleeves and long pants to help protect arms and legs.
- Long-term exposure to wind can cause permanent hearing loss. Properly worn hearing protective devices such as earplugs can help prevent hearing loss. Check local laws or the rules of the riding area you are in before wearing hearing protection to make sure its use is permitted.

SAFETY

Always stay completely inside the vehicle and hold the steering wheel or hand holds. Body parts outside of the vehicle can be struck by passing objects or crushed during a rollover. Do not put any part of your body outside of the vehicle for any reason. Do not hold onto the ROPS frame or put any part of your body on the door/net.

Riding in this vehicle without closed and latched cab doors or nets increases the risk of serious injury or death in the event of an accident or rollover. Always make sure all cab doors/nets are closed and latched while riding in this vehicle.

Be sure riders pay attention and plan ahead. If you think or feel the vehicle may tip or roll, reduce your risk of injury:

- Keep a firm grip on the steering wheel or hand holds and brace yourself.
- Do not put any part of your body outside of the vehicle for any reason.

This vehicle is not designed to carry unrestrained pets. An unrestrained pet can be thrown about and injure riders, even during normal operation. When transporting pets, use a pet crate suitable for off-road use that is secured to the vehicle.

Fuels such as gasoline can be extremely flammable. To reduce the risk of serious injury or death, never carry fuel or other flammable liquids on this vehicle. Rollovers, crashes, rough riding, or changes in elevation or temperature may lead to fuel spilling or vapor release from portable containers. Hot vehicle parts can cause fires, even after the vehicle is powered off.

Never exceed vehicle weight capacities. The vehicle's maximum weight capacity (including riders, cargo, and accessories) can be found in the Specifications chapter. When more rider weight is added, cargo weight may need to be reduced to stay under the limit. Overloading the vehicle or carrying cargo improperly will cause changes in stability and handling, which could cause loss of control or an accident.

Secure cargo in the cargo box as far forward, centered and as low as possible. When cargo cannot be positioned and secured in this way, operate with extra caution. Unsecured cargo can strike and injure riders, affect vehicle handling, and result in loss of control.

The weight of riders and cargo changes vehicle braking, handling, and stability. To avoid loss of control, turn gradually, operate at slower speeds, and avoid rougher or steeper terrain.

DRIVING GUIDELINES

Drive Responsibly. This vehicle has higher ground clearance and other features to handle rugged terrain. It can be overturned in situations where some other vehicles may not. Abrupt maneuvers or aggressive driving, even on flat, open areas, can cause loss of control, rollovers, severe injury or death. To avoid loss of control and rollovers:



- Avoid abrupt maneuvers, sideways sliding, skidding, or fishtailing, and never do donuts.
- Slow down before entering turn.
- Avoid hard acceleration when turning, even from a stop.

High speed off-road operation

Driving off-road vehicles to test the limits of your skills or abilities can be very dangerous to you, passengers, and bystanders. Basic skills for driving a car, ATV, or other off-road vehicles do not equip drivers to safely attempt high speed off-road operation. Develop your skill gradually through training, practice, and experience with the various driving modes of this vehicle and the terrain in which you are operating. Always do a low speed reconnaissance run (prerun) to become aware of anything you may encounter.

High speed off-road operation can lead to loss of control, crashes, or hard landings that can seriously injure occupants (even without rolling the vehicle or damaging it).

If you plan on using the vehicle for high speed, off-road competition, additional safety equipment may be necessary. Check the rules that apply to your competition.

Do not go over jumps — going airborne can lead to serious injury or death.

Going airborne can cause loss of control, rollovers, or crashing into the ground and may damage the vehicle. Even without crashing, landings can be hard enough to cause any vehicle suspension to fully compress (e.g., bottom out). Serious injuries, including spinal injuries, can occur even if riders are properly harnessed, wearing helmets and the vehicle is not damaged and remains upright.

You may encounter slopes, "jumps", or other terrain features that could send the vehicle airborne, depending on your speed. These may be defectively designed, poorly maintained, or not suitable for this vehicle. Slow down, use extra care, and avoid going airborne. Never take this vehicle over jumps.

SAFETY

Watching someone else go over a jump or go airborne does not mean you can safely do so. Polaris cannot determine whether any jump you may encounter is appropriate for this vehicle. Any jump, even a small one, could be poorly maintained, designed, or not suitable for this vehicle and may cause serious injury or death.



Plan for hills, rough terrain, ruts, and other changes in traction and terrain.

Proceed slowly and with extra care on unfamiliar terrain. Avoid paved surfaces. Sudden changes in terrain such as holes, depressions, banks, softer or harder ground, or other irregularities may cause loss of control or rollover. Give yourself time to react to rocks, bumps, or holes that may be hard to see. Operating in deep snow or tall grass may make it harder to see obstacles.

If you cannot go around an obstacle, such as a fallen tree or a ditch, stop the vehicle in a safe place. Get out to inspect the area thoroughly. Look from both your approach side and exit side. If you are reasonably confident you can continue safely, choose the path that will allow you to go straight over the obstacle to minimize the vehicle tipping sideways. Go only fast enough to maintain your momentum, but still give yourself plenty of time to react to changes in conditions. If there is any question about your ability to maneuver safely over the obstacle, you should turn around if the ground is flat and you have the room, or back up until you find a less difficult path.

Abrupt application of the accelerator pedal can cause the tires to lose traction, reducing control of the vehicle and increasing the possibility of an accident, especially while on sloped terrain or while crossing obstacles such as rocks or logs.

Avoid Operating on Public Roads (Paved or Otherwise). This vehicle does not have highway safety features that on-road vehicles may have (air bags, anti-lock brakes, stability control, etc.). If another vehicle collides with you, the likelihood of a serious injury or death may be greater. Also, you may not be able to avoid a crash or rollover if you make sudden or abrupt maneuvers such as swerving or emergency braking.

While it may be legal locally to drive on some public roads in specific parts of the country, your vehicle was not designed or certified as an on-road motor vehicle. Polaris does not support public road use except as may be necessary to cross roads designated for connecting off highway trail segments. If you must drive on-road, drive slowly and defensively. Your vehicle may lack the features needed to comply with state or local laws that permit limited public road use. Modifications you make to your vehicle to meet these requirements may void the vehicle warranty. In addition, refer to tire manufacturer's instructions or limitations for on-road operation, including speed limits and premature tire wear.

Improperly operating on hills can cause loss of control, rollover, or accident, which can lead to serious injury or death. Use extra care when operating on hills. Plan for rough terrain, ruts, and other changes in traction and terrain.

Driving up hills

Check the terrain before ascending a hill and make sure it is not too slippery or loose. Engage all-wheel drive for hills. Drive straight uphill, keeping speed and accelerator steady. Avoid steep hills which can cause the vehicle to overturn.

Recovering from stalling on a hill

If the vehicle loses forward speed, apply the brakes gradually and stop. Do not attempt to turn the vehicle around. Instead, allow the vehicle to slowly roll straight downhill. Apply light brake pressure to control speed.

Overtopping a hill

Slow down when you reach the crest of a hill. Never blindly go over the crest of a hill or a drop off at high speed. An obstacle, a sharp drop, or another vehicle or person could be on the other side of the hill.

Driving down hills

Check the terrain before descending a hill and make sure it is not too slippery or loose. Engage all-wheel drive and proceed slowly, applying the brakes lightly. Never descend a hill with the transmission in neutral or if the motor is turned off.

Avoid side hilling (riding across slopes)

If unavoidable, proceed slowly and with extra caution. Avoid obstacles and changes in terrain that could cause the vehicle to tip or slide. If it feels like the vehicle begins to tip or slide, immediately turn downhill.

Riding near wooded areas or brush

Use extra caution when operating near trees, particularly when operating on narrow trails. Tree branches or brush can be driven into the cab striking or stabbing occupants.



SAFETY

Riding in snow

Always keep the brake and accelerator pedals free of snow and ice. Apply the brakes frequently to prevent ice or snow accumulation on the brake pads which can reduce brake performance.

Riding on ice

Never operate the vehicle on a frozen body of water unless you have verified that the ice can support the weight of the vehicle. Severe injury or death can result if the vehicle falls through the ice.

Riding in water / Falling into water

Operating through deep or fast-flowing water can cause loss of traction, loss of control, overturning, or being swept away in water. You can be seriously injured or killed from entrapment and drowning. Never operate the vehicle in fast-flowing water or in water that exceeds the floor level of the vehicle. Avoid sharp drop-offs and large rocks. Choose a path that provides an entrance and exit point with gradual inclines. Wet brakes may have reduced stopping ability. After leaving water, test the brakes. Apply them lightly several times while driving slowly. The friction will help dry out the pads.

Riding on sand dunes

Use extra caution when operating on or near dunes. Be alert for changes in terrain. Never blindly go over the crest of a hill or a drop-off at high speed. An obstacle, a sharp drop, or another vehicle or a person could be on the other side of the hill.

Riding in low-visibility conditions

Use extra caution and drive slowly in conditions of reduced visibility such as fog, rain, and darkness.

Plan ahead to avoid the need for evasive maneuvers, such as swerving.

Hitting an obstacle — including wildlife — you are not ready for can be dangerous. Choosing to swerve instead can be even more dangerous because it can lead to loss of control, rollover, or collisions.

When operating in areas with possibility of wildlife appearing in your path, plan ahead to avoid swerving for animals if doing so could result in collisions or rollovers. Go slowly or avoid driving during seasons or times of day when animals such as deer are more likely to cross your path without warning.

Avoid Collisions With Other Vehicles

When following another vehicle or operating in the same area as others, keep a safe distance to avoid collisions. Allow extra space when sight distances are limited by dust, snow, curves, hills, or other conditions. Plan ahead to avoid having to swerve or leave the trail to avoid a collision.

On trails, be prepared to make space for other vehicles to pass. If you need to stop on a trail, move your vehicle to the edge of the path to allow others to pass safely.

Correct a skid by turning the steering wheel in the direction of the skid.

Never apply the brakes during a skid.

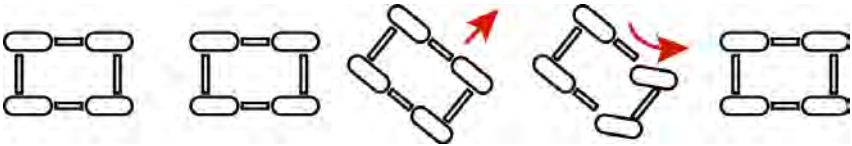

If the vehicle begins to slide downhill or you feel it may tip, turn downhill immediately and stop. Maneuver slowly and carefully until you can drive straight downhill.

Do not continue driving if your vehicle may be damaged or if you were in a crash or rollover.

Operating the vehicle while damaged or after a crash or rollover can cause loss of control, rollover, or accident, which can lead to serious injury or death. If you cannot safely transport the vehicle on your own, contact a recovery and towing service.

After any crash, rollover, or other accident, have a Polaris dealer inspect the vehicle for possible damage, including seat belts, ROPS, brakes, suspension, electrical components, and steering systems.

Be prepared in case your vehicle becomes damaged or disabled, especially in remote areas. Consider in advance how to get help and stay safe until it arrives whenever you ride.

SAFETY

There is a recovery tow point at the front and back of the vehicle to attach a winch or strap.

Use these points at the front^① or rear^② of the vehicle to recover this vehicle if it is stuck, to pull it onto a tow truck, trailer, or to use this vehicle to recover another vehicle. These points are for emergency recovery only and are not for towing vehicles to another location.

Improper recovery may lead to loss of control or vehicle damage. Only attach straps to specified locations. Do not attach to any other point on the vehicle. Only recover a vehicle of equal or lesser size and weight. When recovering a disabled vehicle, place the disabled vehicle's transmission in neutral. Do not move a disabled RANGER faster than 10 mph (16 km/h).

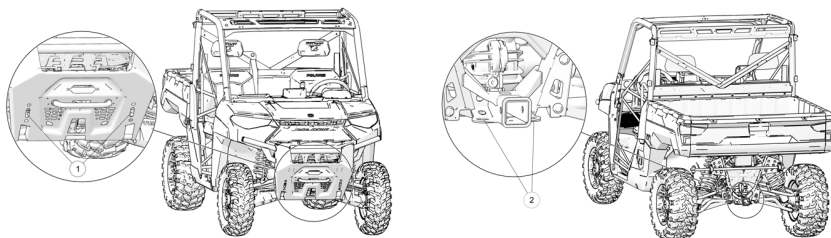

Vehicle rollaway can cause serious injury or death. This vehicle can roll whenever the gear selector is not in the PARK (P) position. Always shift to PARK (P) when stopping the motor or leaving the vehicle. When leaving the vehicle on an incline is unavoidable, use extra care. If leaving the vehicle unattended, block the rear wheels on the downhill side and keep children, pets, and others away from the gear selector.

Before switching to reverse, use extra care to make sure the area is clear of people or obstacles. When it's safe to proceed, back slowly.

After operation, inspect the vehicle for damage and debris to make sure the vehicle can be safely stored and operated again. Some things to inspect include:

- Debris such as mud/grass near the charge port or cooling system
- Damage to the suspension, steering, or any other part of the vehicle
- Tire condition, such as tread and sidewall damage
- Shock absorber assembly condition

Be sure to have any issues checked and problems fixed before operating again.

ELECTRIC VEHICLE SAFETY

This vehicle uses an electric drive system powered by a high-voltage battery pack. There are additional safety precautions for charging, operating, and maintaining the vehicle.

Failure to follow these precautions may cause electric shock, fire, serious injury, or death.

CHARGING SAFETY

Select an appropriate power source

The circuit used to charge the vehicle must:

- Have GFCI protection
- Be rated for at least 15 amps
- Not have other electrical loads

The circuit must also be appropriate for EV charging. Make sure that it is properly grounded and compliant with all local codes and ordinances. If there is doubt as to whether the circuit is appropriate, check with a qualified electrician.

Inspect charging equipment before each use

Make sure the electric vehicle supply equipment (EVSE) connections at the outlet and vehicle charge port are free from dirt and debris. Remove debris with compressed air while wearing eye protection or by rinsing with low pressure water. Do not use tools (e.g., screwdriver) to remove debris.

Before charging, inspect charging components for damage:

- Outlet
- EVSE wall plug
- EVSE cables
- EVSE vehicle plug (J1772)
- Vehicle charge port

If you notice any damage, do not charge until damaged components are replaced.

SAFETY

Properly connect the EVSE

1. Connect the EVSE wall plug directly into the outlet. Never use any device between this connection (e.g., extension cords, grounding adapters, multi-outlet splitters or power strips, surge protectors, timers, or smart home adapters).
2. Position the EVSE cable to keep it from being driven over, stepped on, tripped on, strained, or otherwise damaged.
3. Insert the EVSE charging plug into the charger socket until you hear an audible “click” sound.

Do not charge near flammable materials or vapors. Connecting and disconnecting charging equipment could produce an electric arc.

Additional steps for charging in wet conditions

With the included portable EVSE, the vehicle can be charged in wet conditions if the following precautions are taken:

1. Make sure the EVSE does not become submerged while charging. If the EVSE was submerged while not charging, let it completely dry before using to charge.
2. When connecting to an outdoor power source in wet conditions, only use a weather-resistant outlet (marked with “WR”) with a weatherproof while-in-use cover in the closed position.

The use of international adapters or other 3rd-party charging equipment may affect the ability to charge in wet conditions. Refer to charging equipment manufacturer’s instructions.

Only charge using EVSE

The 12V battery is automatically charged by the high-voltage battery as needed and never requires external charging (e.g., using a trickle charger). If you think there may be a problem with the 12V battery, replace the battery or see your dealer.

To avoid serious injury or death, never attempt to “jump start” this vehicle or connect an external power source directly to the 12V battery. This will not add charge to the high voltage battery. If the vehicle is unresponsive, only charge the high voltage battery using an EVSE.

Using other EVSEs

Polaris recommends using the EVSE provided with the vehicle or other Polaris-approved EVSEs. Other EVSEs may be compatible with this vehicle. Be sure to follow the instructions for any other EVSE used.

ADDITIONAL DRIVING GUIDELINES FOR THIS ELECTRIC VEHICLE

Use extra care when selecting your direction of travel

Failure to select and know your direction of travel can result in the vehicle moving in the opposite direction of what you intend. Each time you enter the vehicle and before you start moving, press the Direction Selector Switch in the forward position (F) to go forward or the reverse position (R) to go rearward. Check the position of the Direction Selector Switch to verify your selection before pressing the accelerator pedal.

Avoid changing the Direction Selector Switch while in motion

If the Direction Selector Switch is changed while the vehicle is traveling above 5 mph (8 km/h), the motor will be de-energized. Once vehicle speed is below 5 mph (8 km/h) and the accelerator pedal is released, the vehicle will respond to the accelerator pedal and move in the selected direction.

Use the brake pedal

The regenerative braking in this vehicle does not allow one-pedal driving (i.e., only using the accelerator pedal). Like most other vehicles, driving this vehicle requires the use of the brake pedal.

Do not store items under the storage bin beneath the seat

Do not store items underneath the storage bin (located under the seat) and on top of the 12V battery. They could contact the battery terminals.

Check for damage to high-voltage components after an accident

Crashes, rollovers, and other impacts can damage the high-voltage battery pack and create a risk of electric shock and fire. The vehicle will indicate that it detects damage through warning lights in the instrument cluster or the Ride Command display, if equipped.

There may also be damage that the vehicle does not detect. After an accident, remove the service disconnect loop (see page 108) and inspect the high-voltage system (e.g., battery, cables, connections, covers). Other signs of damage may include abnormal sounds from the vehicle.

If the high-voltage system is damaged, contact your dealer and do not use the vehicle.

Avoid fire from damaged vehicles

If the vehicle is damaged, shift the vehicle to Neutral (N) and move it outside and away from anything that can burn, if possible. If there are signs of a fire, get away from the vehicle and contact fire emergency responders. Have first responders use a Class D fire extinguisher on electrical components.

SAFETY

IMMEDIATELY RESPOND TO A THERMAL RUNAWAY

Immediately respond to a thermal runaway

If the vehicle detects a thermal runaway, stop and have all occupants move away from the vehicle immediately. Then, contact fire emergency responders. A thermal runaway is an extremely rare event caused by a malfunction or damage to the electronic powertrain system. A thermal runaway occurs when the high-voltage battery rapidly increases in temperature causing additional chemical reactions that continue to increase temperature. This could ultimately result in fire or explosion.

The vehicle will indicate it detects a thermal runaway using the following prompts:

On the Instrument Cluster

The text will scroll the phrase “DANGER EXIT NOW FIRE” and the MIL, AWL, Over Temperature, and high-voltage Battery Pack warning lights will flash. See page 62 for details on Indicator Lamps.



On the Ride Command Display (if equipped)

A red banner will appear on the display screen prompting you to exit the vehicle.



Auditory Alarm

The vehicle will provide an auditory alarm for as long as the vehicle detects a thermal runaway.

Loss of Motor Power

The vehicle will not respond to throttle input and there will be no regenerative engine braking.

No Battery Charge Indicated

The high-voltage battery pack will be disconnected from the motor. Vehicle displays will indicate a state of no charge

MAINTENANCE SAFETY

Do not perform maintenance on high-voltage components

Never try to service high-voltage components. There are no user-serviceable components to the high-voltage system. Always have a qualified technician service high-voltage components.

Do not touch any high-voltage components. High-voltage wiring is orange. Other high-voltage components are labeled.

Do not tamper with or attempt to open the charging equipment or high-voltage battery pack.

Do not remove or dispose of the high-voltage battery pack. Contact an authorized dealer for replacement and disposal.

SAFETY LABELS AND LOCATIONS

Warning labels have been placed on the vehicle for your protection. Read and follow the instructions of the labels on the vehicle carefully. If any of the labels depicted in this manual differ from the labels on your vehicle, always read and follow the instructions of the labels on the *vehicle*.

If an informational or graphic label becomes illegible or comes off, contact your Polaris dealer to purchase a replacement. Replacement *safety* labels are provided by Polaris at no charge. The part number is printed on the label.

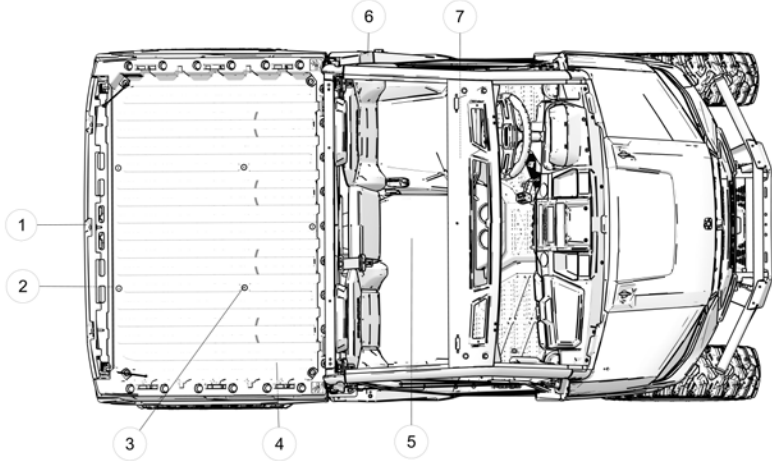

- ① Trailer Weight Maximums (on hitch receiver)
- ② Load/Passenger/Tire Pressure Warning
- ② Maximum Payload Warning
- ③ Component Diagram / Power Wash Warning (under cargo box)
- ④ Fuel Transport Warning
- ⑤ Service Disconnect Warning (under seat)
- ⑥ EVSE Charge Port Warning (inside compartment)
- ⑦ Driver Information Warning (on top ROPS bar)

SAFETY

DRIVER INFORMATION WARNING

WARNING

Improper vehicle use can result in SEVERE INJURY or DEATH.

Be Prepared

- Fasten seat belts.
- Wear an approved helmet and protective gear.
- **ALWAYS** use vehicle cab nets and/or doors.
- Each rider must be able to sit with back against seat, feet flat on the floor, and hands on steering wheel or hand holds. Stay completely inside the vehicle.

Drive Responsibly

Rollovers have caused severe injuries and death, even on flat, open areas.

Avoid loss of control and rollovers:

- Avoid abrupt maneuvers, sideways sliding, skidding or fishtailing, and never do donuts.
- Slow down before entering a turn.
- Avoid hard acceleration when turning, even from a stop.
- Plan for hills, rough terrain, ruts, and other changes in traction and terrain.
- Avoid paved surfaces.
- Avoid side hilling (riding across slopes).

Be Sure Riders Pay Attention and Plan Ahead

If you think or feel the vehicle may tip or roll, reduce your risk of injury:

- Keep a firm grip on the steering wheel or hand holds and brace yourself.
- Do not put any part of your body outside of the vehicle for any reason.

Require Proper Use of Your Vehicle

Do your part to prevent injuries:

- Do not allow careless or reckless driving.
- Make sure operators are 16 or older with a valid driver's license.
- Do not let people drive or ride after using alcohol or drugs.
- Do not allow operation on public roads (unless designated for off-highway vehicle access) - collisions with cars and trucks can occur.
- Do not exceed seating capacity: 3 occupants.

SCAN CODE FOR PRODUCT AND SAFETY INFORMATION. FOLLOW ALL INSTRUCTIONS AND WARNINGS



SERVICE DISCONNECT WARNING

NOTICE

High-Voltage Service Disconnect Located Under Seat Bin

EMERGENCY ONLY

Remove seat bin. Locate service disconnect. Cut wire loop where indicated.

SERVICE

Remove seat bin. Locate service disconnect. Remove by grabbing plastic housing. Do not pull wire loop.

WARNING

Before servicing your vehicle's electrical system, ALWAYS activate the service disconnect.

EVSE CHARGE PORT WARNING

⚠ WARNING

Keep charge port covers closed unless charging. Do not use tools to clean terminals. Remove debris with a cloth or low pressure water.

SAFETY

COMPONENT LOCATION DIAGRAM / POWER WASH WARNING

WARNING

Do not pressure wash electrical components. Reference your owner's manual for cleaning guidelines.



MAXIMUM PAYLOAD WARNING

WARNING

The Maximum Payload Warning label is located on the cargo box.

RANGER XP KINETIC	NEVER EXCEED	IF TOTAL PAYLOAD EXCEEDS
PREMIUM	30 mph (48 kph)	550 lbs (249 kg)
ULTIMATE		

NOTICE

To avoid transmission damage, only shift gears when vehicle is stationary. When the vehicle is stopped, place shifter in PARK position.

TRAILER WEIGHT MAXIMUMS

TRAILER MAX. WEIGHT	2500 lbs. (1134 kg)
HITCH MAX. VERTICAL WEIGHT	250 lbs. (114 kg)

FUEL TRANSPORT WARNING

WARNING

NEVER carry fuel or other flammable liquids on this vehicle.

Failure to follow this instruction could lead to serious burn injuries or death.

Part Number: 7186122 (English) and
7186122-F (French Canadian)



SAFETY

LOAD / PASSENGER / TIRE PRESSURE WARNING

WARNING

- Never carry passengers in cargo box.
- Passengers can be thrown off. This can cause serious injury or death.
- If total payload is greater than 500 lbs. (227 kg), the vehicle must be operated in LOW range.

IMPROPER TIRE PRESSURE OR OVERLOADING CAN CAUSE LOSS OF CONTROL RESULTING IN SERIOUS INJURY OR DEATH.

- Reduce speed and allow greater distance for braking when carrying cargo.
- Overloading or carrying tall, off-center, or unsecured loads will increase your risk of losing control. Loads should be centered and carried as low as possible in box.
- For stability on rough or hilly terrain, reduce speed and cargo.

RANGER XP KINETIC	ULTIMATE	PREMIUM
MAXIMUM CARGO BOX LOAD	1250 lbs. (567 kg)	
MAXIMUM CARGO LOAD WHEN TRAILER TOWING	600 lbs. (272 kg)	
TIRE PRESSURE IN PSI (KPa)	FRONT 12 (83) REAR 14 (97)	
MAXIMUM WEIGHT CAPACITY INCLUDES WEIGHT OF OPERATOR, PASSENGERS, CARGO AND ACCESSORIES	1500 lbs. (680 kg)	
Read Operation and Maintenance Manual for more detailed loading information.		

INTRODUCTION TO EV

ELECTRIC VEHICLE OVERVIEW

Your Polaris electric vehicle (EV) is equipped with an all-electric motor powered by a high-voltage battery pack that can be charged for re-use without the need for fossil fuels or other fluids, filters, and ignition devices associated with internal combustion engines.

The advantages and limitations of EVs should be considered before operating this vehicle. Read the following sections for information on best practices:

- Charging Best Practices(See page 36)
- Weather Best Practices(See page 42)
- Vehicle Range(See page 45)
- Long-term Storage(See page 47)

CHARGING BEST PRACTICES

GOOD CHARGING HABITS

Leave the vehicle plugged in between frequent uses

The vehicle operates best when charged regularly. You do not need to run your battery pack low before charging again as *there is no benefit in letting batteries run low*. Instead of waiting until the State of Charge (SoC) is near empty to recharge the battery pack, take every opportunity to recharge during downtime.

IMPORTANT

If the vehicle is in a “LOW STATE OF CHARGE” (less than 15%), it should be plugged in within 24 hours after being parked to avoid potential damage to the battery and preserve battery health.

NOTE

Charging for frequent use (as described above) and charging for long-term storage require different strategies. For details on long-term storage, see page 47.

Charge in moderate temperatures

Charging in extreme temperatures may limit the rate of charge the battery pack receives. See page 42 for details.

Charge during “off-peak” hours

Peak hours are when electricity demand is the highest amount per kWh. If charging at home, charging the vehicle during off-peak hours will keep charging costs low. Commonly, off-peak hours are at night when electricity consumption is low. Check with your electric companies as some may offer discounts during off-peak hours.

CHARGING YOUR VEHICLE

Follow the procedure below to charge your vehicle.

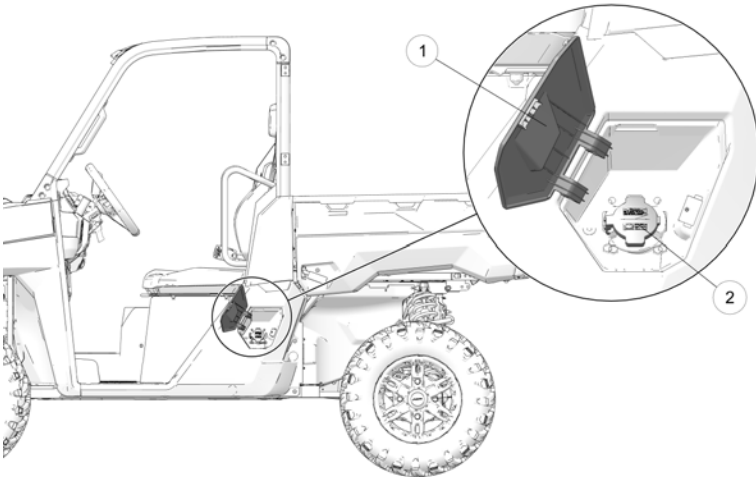

IMPORTANT

Make sure the charge port cover and charge compartment door are fully secured before operating. Operating the vehicle with either left open may allow dirt and debris to damage the terminals.

1. Stop the vehicle on a flat surface.
2. Set the gear selector to PARK (P).
3. Turn the key switch to OFF.
4. Open the charge compartment door ①.

NOTE

Make sure to wipe away any accumulated mud or debris in or around the charge compartment. Do not use tools to clean terminals. Use compressed air, cloth, or (if necessary) low pressure water to clean the charge compartment.

5. Open the charge port cover ②.
6. Insert the EVSE charging plug into the charger socket until you hear an audible “click” sound. Once the vehicle begins charging:
 - The vehicle display will switch to the charging screen.
 - The vehicle will charge continuously until fully charged.

INTRODUCTION TO EV

- The vehicle will not be driveable while EVSE charging plug is connected.
 - Charge performance may vary as a result of ambient temperatures affecting internal battery temperature. See page 42 for details.
7. Once ready to resume operation, remove the EVSE charging plug.
 8. Reattach the charge port cover and close the charge compartment door.

CHARGING COMPONENTS

ELECTRIC VEHICLE SUPPLY EQUIPMENT (EVSE)

Electric Vehicle Supply Equipment (EVSE) is required for charging electric vehicles. The EVSE supplied with your vehicle is a J1772 style port that is Level 1 (120V) and Level 2 (240V) compatible.

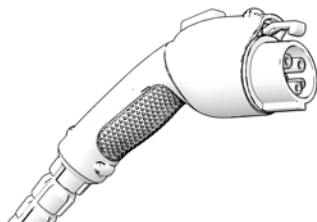

BATTERY PACK ONBOARD CHARGER (OBC)

Onboard Chargers (OBCs) convert AC power to DC voltage that charges the high-voltage battery pack on your vehicle. Electric vehicles can be equipped with different onboard chargers with varying charge rates. For example, a 6 kW onboard charger will charge up to twice as fast as a 3 kW onboard charger when connected to an EVSE with kilowatt output at or above the charger rating.

NOTE

The Battery Pack Onboard Charger does not charge the vehicle without connection to Electric Vehicle Supply Equipment (EVSE) and a power supply.

HIGH-VOLTAGE BATTERY PACK

The high-voltage battery pack carries the energy necessary to operate your vehicle. If you believe there is an issue with the high-voltage battery pack, do not attempt to service. Bring directly to your dealer or other qualified person.

BATTERY MANAGEMENT SYSTEM (BMS)

Your vehicle's high-voltage battery pack is equipped with a Battery Management System (BMS) that monitors the condition of the battery and optimizes charging. Under certain conditions, the BMS will act to prevent damage to the battery, including stopping or slowing the flow of charge.

VEHICLE CHARGE STATUS

Instrument Cluster

When charging the vehicle, the State of Charge (SoC) will be displayed on the instrument cluster and the Ride Command Display (if equipped). Status indicators include:

- ① State of Charge (%)
- ② Battery icon
- ③ Rate of charge (in kW)
- ④ Time until SoC reaches 100%

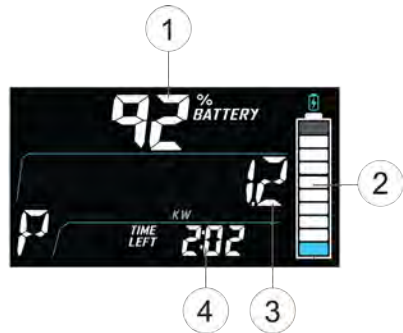

NOTE

If equipped, the Ride Command display will also display charge status while vehicle is charging.

Accent Light Bar

When the accent light switch (see page 54) is in the ON position and the vehicle is charging, the accent light bar ① at the front of the vehicle will pulse as the battery pack charges. Sections of the accent light bar will remain illuminated as a visual representation of State of Charge (SoC) status. When the accent light bar is fully illuminated, the vehicle has reached 100% SoC.

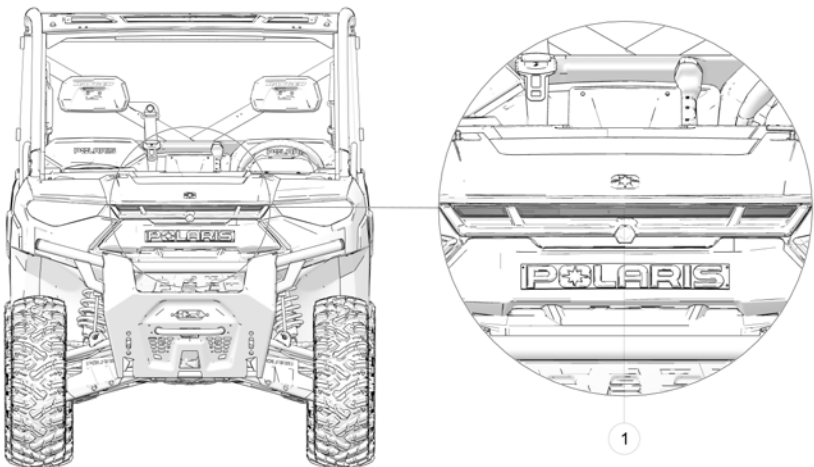

INTRODUCTION TO EV

POWER SOURCES

Your Polaris Electric Vehicle (EV) can receive a charge from multiple kinds of power sources, including:

- 120V home wall outlet
- 240V home wall outlet
- J1772 Level 1 (120V) public charging stations
- J1772 Level 2 (240V) public charging stations
- Type I electrical outlet (Australia and New Zealand)

IMPORTANT

Your vehicle is not compatible with Level 3 public charging stations. Do not attempt to charge your vehicle using a Level 3 charge station.

Not all power sources are equal with regard to charge time. For example, a wall circuit with 120V, 15 amperage service will have a longer charge time than 240V, 40 amperage service.

See the table below for charge time reference. Be sure to understand the voltage service options in your home when charging from home. Consult the Polaris website or your dealer for onboard charger accessory options to reduce charge time.

MODEL	PREMIUM		ULTIMATE	
Battery Pack	14.9 kWh		29.8 kWh	
Power Source	120V Outlet	240V Outlet	120V Outlet	240V Outlet
3 kW Onboard Charger	10 Hours* of Charging (0-100%)	5 Hours* of Charging (0-100%)	N/A	N/A
6kW Onboard Charger	N/A	N/A	20 Hours* of Charging (0-100%)	5 Hours* of Charging (0-100%)
*All charge times shown are approximate				

Power Outlet Types

The EVSE charger supplied with your vehicle includes two attachments for compatibility with 120V and 240V outlets.

- ① NEMA 5-15 (120V)
- ② NEMA 14-50 (240V)

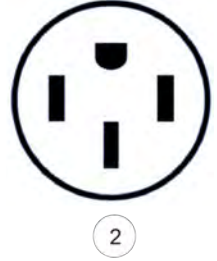

Power Outlet Types (Australia and New Zealand)

The EVSE charger supplied with your vehicle is compatible with Type I electrical outlets.



WEATHER BEST PRACTICES

ELECTRIC VEHICLES AND WATER

Your EV is designed to withstand wet conditions such as rainfall, puddles, snow, or muddy terrain. However, submersion in water past the floor level or the use of high-pressure hoses on inner components will void the warranty and may cause faults or make the vehicle temporarily inoperable. If this happens, have a dealer inspect the vehicle and allow the vehicle components time to dry until the vehicle is operable again.

BATTERY PACK HEATERS

The high-voltage battery pack on your vehicle is equipped with automatic heaters that sense when the battery's internal temperature is below 50° F (10° C). This allows your vehicle to operate normally in below-freezing conditions.

If the battery temperature falls below 50° F (10° C), the battery heaters activate when:

- the vehicle is charging, or
- the key switch is in the ON position

NOTE

If the vehicle's State of Charge (SoC) falls below 5%, the battery pack heaters will not activate in order to conserve energy for driving. If the vehicle's SoC falls below 15%, the battery pack heaters will not activate unless battery internal temperature is below -4° F (-20° C).

In cold conditions, always allow several minutes for the battery pack heaters to warm up before operating. This helps prevent sluggish performance, reduced speed, longer charge times, and shorter vehicle range.

CHARGING IN EXTREME AMBIENT TEMPERATURES

When the vehicle's high-voltage battery pack has an internal temperature outside of the ideal range, the Battery Management System (BMS) will either slow the rate of charge or stop charging altogether until the battery pack temperature has returned to the ideal range. A warning will appear on the Ride Command display (if equipped) and instrument cluster when this occurs.

NOTE

Battery pack internal temperature may differ from ambient temperature.

BATTERY PACK INTERNAL TEMPERATURE	CHARGE PERFORMANCE
Above 122° F (50° C)	No Charge
104° to 122° F (40° to 50° C)	Reduced
50° to 104° F (10° to 40° C)	Normal
-13° to 50° F (-25° to 10° C)	Reduced*
-39° F to -13° F (-40° C to -25° C)	No Charge*
At or Below -40° F (-40° C)	No Charge

*This will be temporary. Allow several minutes for the battery pack heaters to warm up to the point where normal charge performance resumes.

VEHICLE PERFORMANCE IN EXTREME AMBIENT TEMPERATURES

The high-voltage battery pack internal temperature and State of Charge (SoC) can affect performance. A vehicle may experience reduced performance or become inoperable if levels fall outside of a certain range.

The chart below details conditions that may cause reduced performance or vehicle shutdown when the vehicle is not connected to an EVSE charger and power supply.

NOTE
Battery pack internal temperature may differ from ambient temperature.

BATTERY PACK INTERNAL TEMPERATURE	STATE OF CHARGE (SOC)		
	LESS THAN 5%	LESS THAN 15%	GREATER THAN 15%
<i>Below</i> -22° F (-30° C)	Vehicle will not operate.	Vehicle will not operate.	Vehicle will not operate.
<i>Greater than</i> -22° F (-30° C)	Battery heaters inactive. Reduced performance.	Battery heaters* only active if battery temperature is	Allow several minutes for battery heaters*

INTRODUCTION TO EV

BATTERY PACK INTERNAL TEMPERATURE	STATE OF CHARGE (SOC)		
	<i>LESS THAN 5%</i>	<i>LESS THAN 15%</i>	<i>GREATER THAN 15%</i>
		below -4° F (-20° C). Reduced performance.	to warm up. Normal performance.
<i>Greater than 50° F (10° C)</i>	Reduced performance.	Reduced performance likely.	Normal performance.
<i>Greater than 131° F (55° C)</i>	Reduced performance.	Reduced performance.	Reduced performance.
<i>Greater than 140° F (60° C)</i>	Vehicle will not operate.	Vehicle will not operate.	Vehicle will not operate.
*Battery pack heaters will not activate unless the key switch is in the ON position when vehicle is not connected to an EVSE charger and power supply.			

VEHICLE RANGE

FACTORS THAT INFLUENCE VEHICLE RANGE

When estimating the distance your Polaris Electric Vehicle (EV) can travel in a single charge, be sure to take into account the following factors:

Terrain

Hill climbs, mud, and sand put more demand on your vehicle.

Style of Driving

Sporty driving requires more power than conservative driving.

Weather

Strong headwinds, slippery conditions, or extreme ambient temperature can decrease driving range and performance.

Payload

Passengers, cargo, or towing places more demand on your vehicle.

Tire Pressure

Low tire pressure causes increased drag and demand on your vehicle.

Differential Used

2x4, 4x4, or high/low require different levels of motor output and energy consumption.

Frequency of Starts and Stops

More energy is used to accelerate to cruising speed than maintaining cruising speed.

Accessories

Larger tires, cab heater, lighting, and audio can increase energy draw from the high-voltage battery pack.

With low loads, smooth terrain, and a conservative driving style, vehicle range will approximate to the following:

MODEL	RANGE (ON FLAT GROUND)*
RANGER XP KINETIC Premium	Up to 45 mi. (72 km)
RANGER XP KINETIC Ultimate	Up to 80 mi. (129 km)
*Range estimates based on manufacturer data on typical customer driving usage and conditions. Actual range varies based on conditions such as external environment, weather, speed, cargo loads, rates of acceleration, vehicle maintenance, and vehicle usage.	

ESTIMATED REMAINING RANGE

When the vehicle is powered on and not charging, the estimated remaining range (in miles or kilometers) can be found on the instrument cluster or Ride Command display (if equipped). See page 66 for details on instrument cluster navigation.

Your vehicle's displayed range estimate is a calculation based on current State of Charge (SoC) and power consumption data gathered from previous rides. Calculations are made in real-time to provide adaptable estimates for varying driving styles.

Factors from previous rides that affect estimated driving range include:

- Accelerator pedal inputs
- Speeds
- Terrain conditions



NOTE

Power consumption data from previous rides may cause range estimates to vary even when State of Charge (SoC) is at 100%. The displayed range estimate is not an indicator of battery pack condition or degradation.

HIGH-VOLTAGE BATTERY PACK DEGRADATION

All batteries will degrade over time because of their chemical makeup. However, the Lithium-Ion batteries in RANGER XP Kinetic electric vehicles are designed to provide an extremely long, useful life. It could take up to 10 years or 10,000 miles to see a noticeable reduction in battery capacity and resulting range, expected to be about 5-10% at most.

REGENERATIVE BRAKING

Whenever your vehicle is moving and accelerator pedal is released or the brake is applied, the regenerative braking system recaptures surplus kinetic energy for the battery. The vehicle's regenerative braking level is displayed on the instrument cluster. See page 61 for details.

LONG-TERM STORAGE

IDEAL CONDITIONS FOR STORAGE

For planned long-term storage of more than 30 days, follow the recommendations below to create the ideal storage conditions for your Polaris Electric Vehicle (EV) and maintain the lifespan of the high-voltage battery pack.

Store in Cool, Dry Areas

Recommended Storage Temperature Range	32° F to 113° F (0° C to 45° C)
---------------------------------------	------------------------------------

Store When State of Charge (SoC) is at 60%

Putting your EV into storage with 100% charge is *not* recommended, as it may accelerate battery cell aging. Instead, operate the vehicle until SoC has fallen to 60% (or charge until 60% is reached), then place the vehicle in storage.

Check monthly to make sure State of Charge (SoC) does not fall below 30%

While in storage, the SoC will gradually drain. Check the SoC monthly to ensure it has not fallen below 30%. If SoC is below 30%, charge back up to 60%.

NOTE

The battery pack can be discharged to the point where it is no longer able to be charged (also known as non-recoverable). Your vehicle is designed to prevent this and will hibernate after 30 days of non-use with no charging. It is still recommended to charge the vehicle occasionally to ensure the battery pack stays charged.

24-Hour Charge Before Next Use

When the storage period has ended, charge the vehicle for 24 hours before initial use. This will allow enough time for optimal battery cell balance to be restored.

FEATURES AND CONTROLS

NEAR-FIELD COMMUNICATION (NFC) (IF EQUIPPED)

Some Polaris vehicles come equipped with a near-field communication (NFC) chip. The NFC chip is embedded in the Polaris emblem located at the front of the vehicle and seamlessly connects you to a digital platform of vehicle information and tools. See your dealer for more information.

IMPORTANT

Not all devices are equipped with an NFC reader. Additionally, some devices require third party applications to access NFC content. For questions regarding the NFC reader on your device, refer to the device's user manual.

On models equipped with NFC, place your smartphone directly over the Polaris emblem to do the following:

- View vehicle-specific information
- Access your Polaris Garage
- Download and view the owner's manual
- View accessory instructions
- Watch how-to videos
- Access warranty information
- Check for service notifications



RIDE COMMAND WITH NFC

Additional NFC features are available when using the Ride Command mobile app. To access these features, do the following:

1. Download the Ride Command mobile app from the Apple App Store® or Google Play® store.
2. Create or log in to an existing account.
3. From the Ride Command mobile app home screen, select **Add Vehicle**.
4. On the vehicle, tap the NFC-enabled badge with the phone to scan the vehicle.
5. Confirm information, name your vehicle, and tap add to garage.

SYSTEM REQUIREMENTS

Refer to device manufacturer's instructions to verify NFC read capability, and/or NFC-capable add-ons.

COMPONENT LOCATIONS

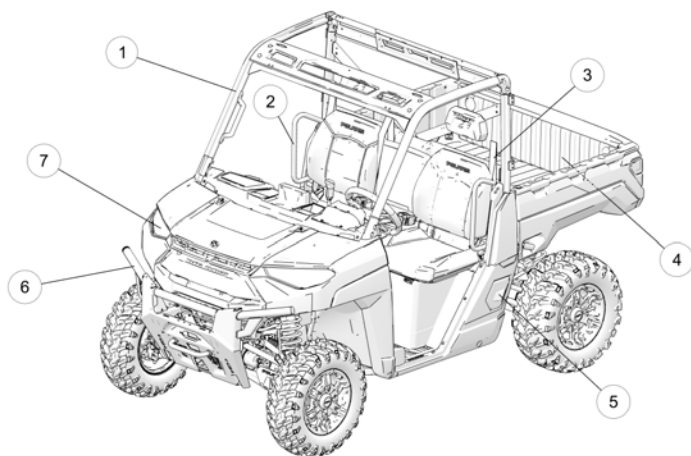

- ① ROPS Frame
 - ② Hip Bar
 - ③ Seat Belt
 - ④ Cargo Box
 - ⑤ Charge Compartment Door
 - ⑥ Front Bumper/Brush Guard
 - ⑦ Headlight
-
- ⑧ Cargo Box Release Lever
 - ⑨ Receiver Hitch
 - ⑩ Tailgate Latch
 - ⑪ Taillight

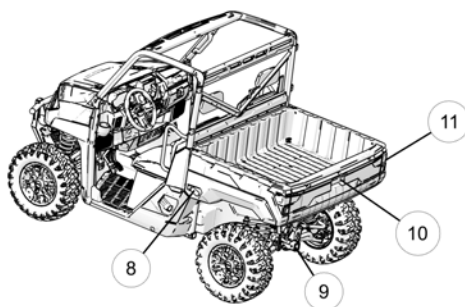

CONSOLE

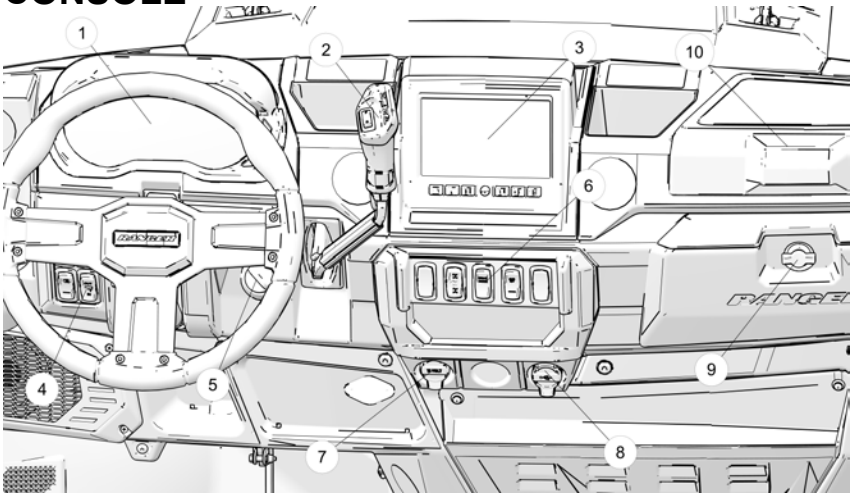

- | | |
|--------------------------------------|-----------------------------|
| ① Instrument Cluster | ⑥ Right-side Switch Cluster |
| ② F/R Switch and Gear Selector | ⑦ 12V Accessory Outlet |
| ③ Ride Command Display (if equipped) | ⑧ USB Outlet |
| ④ Left-side Switch Cluster | ⑨ Lower Storage Compartment |
| ⑤ Key Switch | ⑩ Upper Storage Compartment |

FEATURES AND CONTROLS

AUXILIARY OUTLET

The vehicle is equipped with a 12V–10A accessory outlet on the dash. Use the outlet to power an auxiliary light or other optional accessories or lights. For service, the dash outlet connection is under the dash.



USB PORT

The vehicle is equipped with a USB outlet on the dash. The outlet consists of two USB terminals. For service, the dash outlet connection is under the dash.



SWITCHES

KEY SWITCH

NOTE

Vehicle may be charged with the Key Switch in the ON or OFF position.

Turn the key to the ON position to activate the electrical circuits. Turn the key to the OFF position to disable all electrical circuits. The key can be removed from the switch when it is in the OFF position.

DRIVE MODE SWITCH

The Drive Mode Switch allows for toggling between three different performance settings - **Eco+ Mode**, **Standard Mode**, and **Sport Mode**. The selected mode can be viewed on the instrument cluster when the vehicle is powered on.

Eco+ Mode

Optimizes torque and top speed for maximum range and quiet operation while performing light duty jobs in moderate terrain.

Standard Mode

Optimizes throttle response for full performance and precision needed for toughest jobs and rough terrain.

Sport Mode

Optimizes throttle response for spirited driving and sporty pedal feel for recreational/trail riding.

Press the top of the switch to toggle between Drive Modes. The vehicle can switch between modes while in motion, but the accelerator pedal must be fully released while the switch is pressed.



HEADLIGHT SWITCH

The ignition switch key must be in the ON position to operate the headlights.

- Press the top of the rocker switch to place the headlights on HIGH BEAM.
- Move the rocker switch to the center position to place the headlamps on LOW BEAM.
- Press the bottom of the rocker switch to turn OFF the headlights.



FEATURES AND CONTROLS

ACCENT LIGHT SWITCH

Press the top of the switch to turn the front accent light bar on. Press the bottom of the switch to turn the accent light bar off. The accent light bar can also visually display charge status when the switch is in the ON position while the vehicle is charging. See page 39 for details.



DIRECTION SELECTOR SWITCH

The direction selector switch ① is located on the gear selector. Pressing the accelerator pedal while the vehicle is in HIGH (H) or LOW (L) gear will move the vehicle in the direction indicated by the direction selector switch.

- Press FORWARD (F) to drive the vehicle forward.
- Press REVERSE (R) to drive the vehicle in reverse.

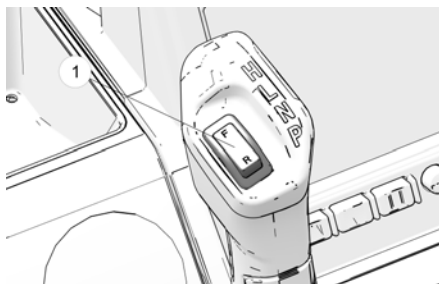

NOTE

Avoid changing vehicle direction while in motion. Bring the vehicle to a complete stop, and then press the switch to the desired setting.

AWD SWITCH

The AWD switch has three positions: All Wheel Drive (AWD), Differential Lock/Two Wheel Drive (2WD) and Off (1WD / Turf Mode).

Press the top of the switch to engage All Wheel Drive (AWD).

Move the switch to the center position to lock the differential and operate in two wheel drive (2WD).

Press the bottom of the switch to unlock the differential and allow the rear drive wheels to operate independently (1WD / Turf Mode). This mode of operation is well suited to turf driving or when active traction is not needed.

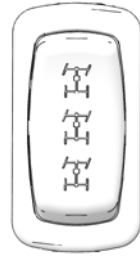

AUX SWITCH

The AUX switch activates power to the rear auxiliary 12V-15A SAE plug. The rear plug is not active/live until the AUX switch is in the ON position.

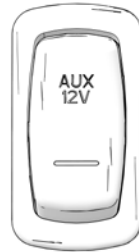

The rear auxiliary 12V-15A SAE port ① is located on the rear driver-side corner of the cargo box.

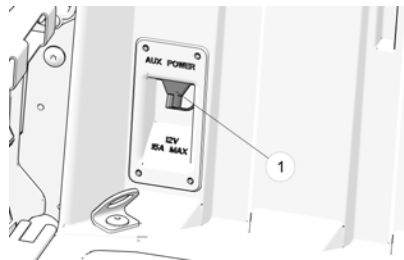

FEATURES AND CONTROLS

GEAR SELECTOR

To change gears, stop the vehicle and move the lever ① to the desired gear. Do not attempt to shift gears while the vehicle is moving.

- H: High Gear
- L: Low Gear
- N: Neutral
- P: Park

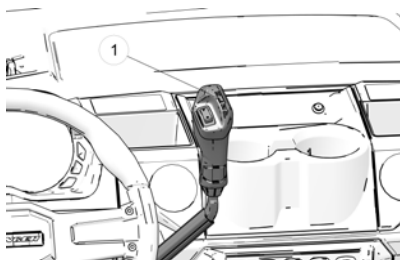

NOTICE

Only change gears when the vehicle is stationary.

STEERING WHEEL

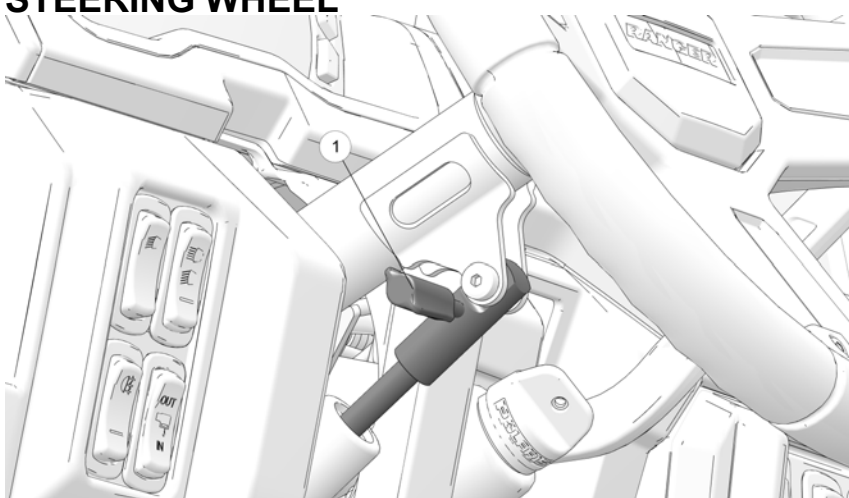

The steering wheel can be tilted upward or downward for rider preference.

Lift and hold the steering wheel adjustment lever while moving the steering wheel upward or downward. Release the lever when the steering wheel is at the desired position.

Always make sure the steering wheel position does not impede proper operation of the brake pedal, accelerator pedal, and all other controls.

FOOT PEDALS

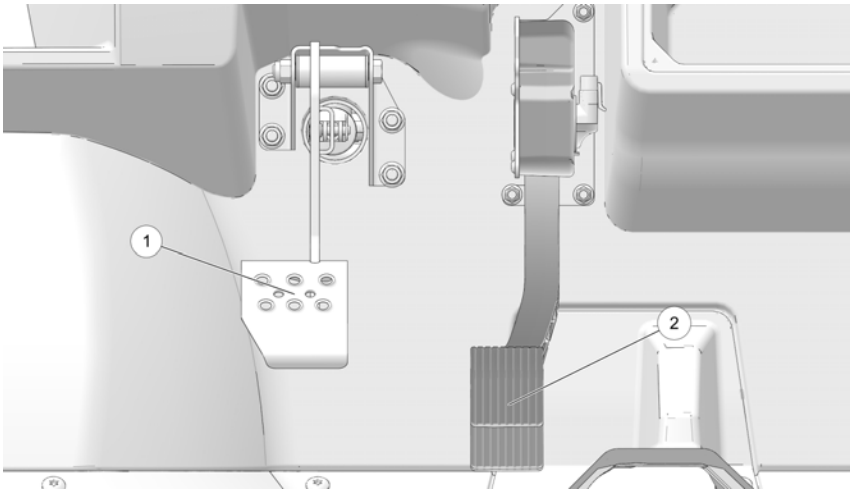

BRAKE PEDAL

Depress the brake pedal ① to slow or stop the vehicle. Regenerative braking will be active whenever the brake pedal is used while vehicle is in motion. See page 46 for details.

When the brake pedal is depressed, the brake light comes on. Check the brake light before each ride.

1. Turn the key switch to the ON position.
2. Apply the brakes. The rear brake lights should come on after about 10 mm (0.4 in.) of pedal travel.

ACCELERATOR PEDAL

Push the accelerator pedal ② down to accelerate the vehicle. Spring pressure returns the pedal to the rest position when released. Always check that the accelerator pedal returns normally before starting the motor.

TIP

If the accelerator pedal and brake pedal are applied simultaneously, motor power may be limited.

SEAT SEAT BELTS

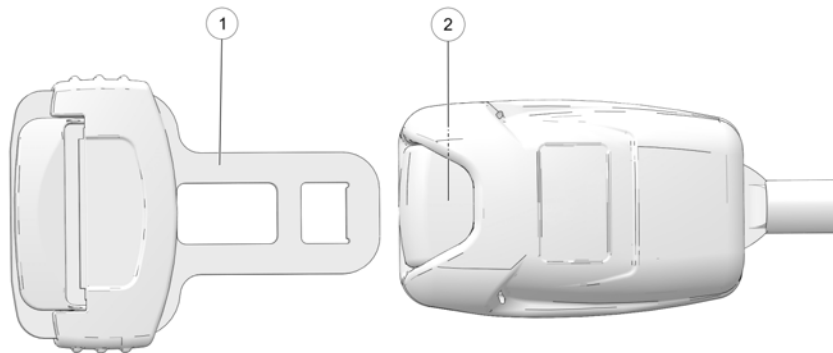

This vehicle is equipped with three-point lap and diagonal seat belts for the operator and any passengers. Always make sure the seat belts are secured for all riders before operating. The driver's seat belt is equipped with a seat belt interlock. Vehicle speed will be limited to 15 MPH (24 km/h) if the seat belt is not secured.

WARNING

Falling from a moving vehicle could result in serious injury or death. Always fasten your seat belt securely before operating or riding in the vehicle.

To wear the seat belt properly, follow this procedure:

1. For 3-point belts, pull the seat belt latch ① downward and across your chest toward the buckle at the inner edge of the seat. The belt should fit snugly across your hips and diagonally across your chest. Make sure the belt is not twisted.
2. Push the latch plate ① into the buckle ② until it clicks.
3. Release the strap, it will self tighten.
4. To release the seat belt, press the square red button in the buckle's center.

SEAT BELT INSPECTION

WARNING

Failure to perform regular inspection can reduce the effectiveness of the seat belt during a crash and could result in serious injury or death.

Inspect all seat belts for proper operation before each use of the vehicle.

1. Push the latch plate into the buckle until it clicks. The latch plate must slide smoothly into the buckle. A click indicates that it's securely latched.
2. Push the red release latch in the middle of the buckle to make sure it releases freely.
3. Pull each seat belt completely out and inspect the full length for any damage, including cuts, wear, fraying or stiffness. If any damage is found, or if the seat belt does not operate properly, have the seat belt system checked and/or replaced by an authorized dealer.
4. To clean dirt or debris from the seat belts, sponge the straps with mild soap and water. Do not use bleach, dye or household detergents. Rinse the entire length of the belt webbing. Use a garden hose to flush out the retractor and latch housings regularly.

SEAT AND STORAGE COMPARTMENTS

The electrical compartment is located under the center rear-most seat. Never use this area for storage. Storage compartments are located under all other seats. Remove the storage bin under the center rear-most seat to access the battery and electrical compartment.

Always make sure all seats are properly installed before operating.

DRIVER'S SEAT (IF EQUIPPED)

To access the storage area under the driver's seat, reach behind the driver's seat and pull up on the latch. Roll the bottom of the seat forward toward steering wheel.

PASSENGER'S SEAT

To access the storage area under the passenger seat, lift up on the front of the passenger seat and raise it to the upright position.

ROLLOVER PROTECTIVE STRUCTURE (ROPS)

The Rollover Protective Structure (ROPS) on this vehicle meets OSHA® 1928.53 rollover performance requirements. Always have your authorized dealer thoroughly inspect the ROPS if it ever becomes damaged in any way.

FEATURES AND CONTROLS

No device can assure occupant protection in the event of a rollover. Always follow all safe operating practices outlined in this manual to avoid vehicle rollover.

WARNING

Vehicle rollover could cause severe injury or death. Always avoid operating in a manner that could result in vehicle rollover.

TRAILER HITCH BRACKET

This vehicle is equipped with a receiver hitch bracket for a trailer hitch. Trailer towing equipment is not supplied with this vehicle.

To avoid injury and property damage, always heed the warnings and towing capacities.

CAB NETS

Always inspect cab nets and latches for tightness, wear and damage before each use of the vehicle. Use the strap adjusters to tighten any loose straps. Promptly replace worn or damaged cab nets and latches with new cab nets and latches. Your Polaris dealer or qualified technician can assist.

SECURING THE NET

1. Position the lower net rod into the mount at floor level.
2. Connect the latch at the top edge of the net to the receiver latch mounted on the front frame.

OPENING THE NET

1. To exit the vehicle, release the top front latch.
2. Rotate the net rearward and slide the lower net rod out of the mount to remove it.
3. Allow the net to hang freely outside the vehicle while dismounting.

INSTRUMENT CLUSTER

NOTICE

High water pressure may damage components. Wash the vehicle by hand or with a garden hose using mild soap. Certain products, including insect repellents and chemicals, will damage the speedometer lens and other plastic surfaces. Do not use alcohol to clean the instrument cluster. Do not allow insect sprays to contact the lens.



- ① Speedometer
- ② Accelerator/Brake Regen Power Level (%)
- ③ Indicator Lamps
- ④ MODE Button
- ⑤ Toggle Buttons
- ⑥ Rider Info Center

SPEEDOMETER

The speedometer displays vehicle speed in either miles per hour (MPH) or kilometers per hour (km/h).

MOTOR POWER LEVEL

The POWER% level displays the percentage (%) of motor power applied as a result of pushing down on the accelerator pedal.

REGENERATIVE BRAKING LEVEL

The REGEN level displays the percentage (%) of available regenerative braking torque applied. See page 46 for details.

MODE AND TOGGLE BUTTONS

Press and hold the MODE button to enter or exit the settings menu. Press and release the MODE button to cycle through Area 1 modes and to select an item. See page 66 for details.





FEATURES AND CONTROLS

Press and release either toggle button to cycle through the options menu or Area 2 modes. Press and hold either toggle button to reset an item.







TIP

With the key switch in the OFF position, pressing the MODE button or either toggle button will power up the Rider Information Center for 10 seconds to allow viewing of the odometer and the clock.





INDICATOR LAMPS

INDICATOR	ICON	FUNCTION
Vehicle Speed	MPH	When standard mode is selected, speed displays in miles per hour.
	km/h	When metric mode is selected, speed displays in kilometers per hour.
High-Voltage Battery Pack		This indicator illuminates when a failure or fault has occurred in the vehicle's high-voltage battery pack.
Check 12V Battery		This indicator illuminates when the 12V battery is exhibiting low voltage.
Over Temperature		This indicator illuminates when components of the electronic powertrain (such as the motor or high-voltage battery) are overheating. Continued operation may result in reduced performance to allow powertrain component temperatures to recover.
EPS Warning (if equipped)		This indicator illuminates briefly when the key is turned to the ON position. If the light remains on, the EPS system is inoperative. See your dealer or other qualified person as soon as possible for repair. Continued operation could result in permanent damage to the EPS unit and increased steering effort.

FEATURES AND CONTROLS

INDICATOR	ICON	FUNCTION
Amber Warning Light (AWL)		This indicator illuminates when an error condition or minor fault has been detected by the vehicle's computer. Consult page 73 and page 130 to identify the condition/fault detected. See your dealer or other qualified person if the condition/fault persists.
Malfunction Indicator Light (MIL)		This indicator illuminates when an error condition or serious fault has been detected by the vehicle's computer. Consult page 73 and page 130 to identify the condition/fault detected. See your dealer or other qualified person if the condition/fault persists.
Helmet/Seat Belt		This indicator illuminates as a reminder to the operator to ensure all riders are wearing helmets and seat belts before operating. The driver's seat belt is equipped with a seat belt interlock. Vehicle speed will be limited to 15 MPH (24 km/h) if the seat belt is not secured.
High Beam		This indicator illuminates when the headlamp switch is set to high beam.
Park Brake (if equipped)		This indicator illuminates when the Park Brake is applied (if equipped).
Speed Limitation Indicator		This indicator illuminates when the Speed Limitation function is active.

FEATURES AND CONTROLS

INDICATOR	ICON	FUNCTION
Active Status Indicator		This indicator illuminates when the vehicle accelerator pedal is active. Pressing on the accelerator pedal when this light appears will result in movement in the direction selected (forward or reverse).
Charging Indicator		This indicator illuminates to confirm the vehicle is connected to a charger. It does not confirm the flow of charge to the vehicle, which is only confirmed by text on the Rider Information Center or the Ride Command display (if equipped). If this light flashes, an error has occurred and the vehicle will not charge.
Brake Failure Indicator (International Models Only)		This indicator illuminates when a brake fault or failure has occurred.
Overspeed Indicator		This indicator illuminates when the vehicle's Speed Limitation function is active and the vehicle travels at speeds in excess of the set limitation (such as when moving downward on a hill).
Cold Temperature Indicator		This indicator illuminates when vehicle components are below their ideal operating temperature; 32° F (0° C). The vehicle may experience reduced performance when this light is active. Allow the battery heaters several minutes to warm up before operating. See page 42 for details on extreme weather operation.

RIDER INFORMATION CENTER

①	Gear Indicator	This indicator displays gear shifter position. H = High Gear L = Low Gear N = Neutral R = Reverse P = Park – = Gear Signal Error (or shifter between gears)
②	Drive Mode Indicator	This indicator shows whether ECO+, STANDARD, or SPORT Mode is active. See page 53 for details.
③	Service Indicator	A flashing wrench symbol alerts the operator that the preset service interval has been reached. Your Polaris dealer, or other qualified person, can provide scheduled maintenance. See page 71 for resetting instructions.
④	Remaining Charge Gauge	The segments of the charge gauge show the level of charge held by the high-voltage battery pack(s). When the last segment clears, a low charge warning is activated. The outline of the charge display will flash. Recharge the vehicle.
⑤	Speed Limitation (if equipped)	This vehicle may be equipped with a maximum speed limitation function. This would be displayed on the screen as "LIM" followed by the speed. "LIM 30" for example.

The rider information center is located in the instrument cluster. All segments will light up for one second at start-up.

The information center is set to display standard units of measurement and a 12-hour clock at the factory. To change to metric and/or a 24-hour clock hold the mode button and cycle to the clock menu. Use the directional arrows to change the clock settings.

If the instrument cluster fails to illuminate, a battery over-voltage may have occurred and the instrument cluster may have shut off to protect the electronic speedometer. If this occurs, your Polaris dealer, or other qualified person, can provide proper diagnosis.



FEATURES AND CONTROLS

MODE INFORMATION DISPLAYS

The rider information center contains three areas that display mode information.



① Area 1 Modes	Description
Battery Pack State of Charge (SoC)	Remaining battery pack charge (%)
Vehicle Speed	Speed of vehicle (MPH/KPH)
Motor Power Level	Motor power applied as a result of pushing down on the accelerator pedal (%)
② Area 2 Modes	Description
Odometer	The odometer records and displays the distance traveled by the vehicle.
Trip Meters (T1/T2)	A trip meter records the distance traveled by the vehicle if reset before each trip. To reset, see page 70.
Ambient Temperature	Displays the ambient temperature sensed by the vehicle. See page 70 to set desired units.
Efficiency (Watt-hours per mile/km)	Displays average battery pack output per mile/km traveled.
Range	Estimated remaining range (miles/km). See page 46 for details on how estimated remaining range is calculated.
Service Interval	A flashing wrench symbol indicates that the preset service interval has been reached. To reset, see page 71.
③ Area 3 Modes	Description
Clock	The clock displays time in a 12-hour or 24-hour format. To reset, see page 69.

ACCESSING MENUS AND OPTIONS

GAUGE SETTINGS MENU

NOTE

Vehicles equipped with a Ride Command display may have fewer selections available through the instrument cluster OPTIONS screen. Certain selections would only be accessible by using the Ride Command display.

Press and release the MODE button to cycle through the Area 1 modes until the desired default mode displays. See the Mode Information Displays section for details.

Press and hold the MODE button to enter the settings menu.

The OPTIONS screen will display for a few seconds.

1. Press and release either toggle button to cycle to the desired option.
2. Press MODE to select the option.
3. Press either toggle button to cycle to the desired setting.
4. Press MODE to save and exit to the settings menu.
5. Press and hold the MODE button to exit the settings menu.



FEATURES AND CONTROLS

EV INFO

Electric vehicle (EV) component details can be viewed using the EV INFO option.

1. Press and hold the MODE button to enter the settings menu.
2. Press either toggle button to cycle to the "EV INFO" option. Press MODE to select.
3. Press either toggle button to cycle to the desired electric component status.
 - Motor Temperature
 - Motor Control Unit (MCU) Temperature
 - Vehicle Dynamics Control (VDC)
 - Battery Pack Life Efficiency (Wh per mile/km)
 - Battery Pack Temperature
4. Press MODE to return to the settings menu.



BACKLIGHT COLOR

The information center backlight can be set to either blue or red.

1. Press and hold the MODE button to enter the settings menu.
2. Press either toggle button to cycle to the "BL COLOR" option. Press MODE to select.
3. Press either toggle button to cycle to the desired setting.
4. Press MODE to save and exit to the settings menu,



BACKLIGHT BRIGHTNESS

The information center backlight can be adjusted to desired brightness.

1. Press and hold the MODE button to enter the settings menu.
2. Press either toggle button to cycle to the "BL LEVEL" option. Press MODE to select.
3. Press "UP" button to increase brightness. Press "DOWN" button to decrease brightness.
4. Press MODE to select and exit to the settings menu.



CLOCK

The clock must be reset any time the battery has been disconnected or discharged.

1. Press and hold the MODE button to enter the settings menu.
2. Press either toggle button to cycle to the "CLOCK" option. Press MODE to select.
3. Press either toggle button to cycle to the desired setting (12H or 24H). Press MODE to select.
4. Press either toggle button to change each segment of the clock. Press MODE to accept a change and advance to the next segment.



PERFORMANCE LIMITATION (IF EQUIPPED)

1. Press and hold the Mode button to enter the settings menu.
2. Use the toggle buttons to find the Speed Limitation screen (SPD LIM). Press the MODE button to select.
3. Choose your desired maximum speed (between 30-85 km/h) by using the toggle buttons.



FEATURES AND CONTROLS

The Speed Limitation feature is disabled automatically when the MODE button is pressed again or ignition switch is in the OFF position.

DISPLAY UNITS (STANDARD/METRIC)



1. Press and hold the MODE button to enter the settings menu.
2. Press either toggle button to cycle to the desired “UNITS” option (distance, temperature or volume). Press MODE to select.
3. Press either toggle button to cycle to the desired setting.
4. Press MODE to save and exit to the settings menu.

TRIP METER

Use a trip meter to track the distance traveled during a specific trip or period of time. Reset the meter to zero before traveling.

1. Press either toggle button to cycle to the desired trip meter option (T1 or T2).
2. Press and hold either toggle button until the meter resets to zero.



TRIP TIME

Use a trip time meter to track the travel time during a specific trip. Reset the meter to zero before traveling.

1. Press either toggle button to cycle to the trip time option (TT).
2. Press and hold either toggle button until the meter resets to zero.



PROGRAMMABLE SERVICE INTERVAL

The service interval counter is programmed to 25 miles at the factory. As vehicle operation increases, the counter decreases. The wrench icon will flash for about 10 seconds when the counter reaches zero (0), and each time the key is turned on thereafter, until the counter is reset.

When this feature is enabled, it provides a convenient reminder to perform routine maintenance. Refer to the Periodic Maintenance Chart for recommended service intervals.

Use the following procedure to reset or change the service interval.

1. Press and hold the MODE button to enter the settings menu.
2. Press either toggle button to cycle to the "SERVICE" option. Press MODE to select.
3. Press MODE to reset the existing value and exit, or press either toggle button to change the value. Press MODE to save and exit to the settings menu.



PIN ACTIVATED SECURITY SYSTEM (P.A.S.S.) (IF EQUIPPED) — INSTRUMENT CLUSTER

The optional PIN Activated Security System (P.A.S.S.) is to prevent unauthorized use. When enabled, the vehicle cannot be operated until a valid passcode has been entered using the Instrument Cluster.

To enable/disable P.A.S.S. using the Instrument Cluster, follow the procedures below.

ENABLE P.A.S.S.

NOTICE

After activating P.A.S.S. for the first time you must power down the vehicle and allow the electronic control module (ECM) to fully shutdown before restarting. This may take up to three minutes.

Once a new passcode has been enabled, it cannot be changed unless you first disable the system. Then you can re-follow the steps outlined in the ENABLE P.A.S.S. section to enter a new passcode.

1. Press and hold the MODE button to enter the "OPTIONS" menu.
2. Use the UP/DOWN toggle buttons to cycle through options until "REQUIRE PIN TO START" appears. Press the MODE button to select.

FEATURES AND CONTROLS

3. If required, "ENTER NEW PIN" will appear. Use the UP/DOWN toggle buttons to cycle to your desired first digit. Press the MODE button to select the digit.
4. Continue until all four digits of your desired passcode have been selected. Once finished, "NEW PIN SET" will flash momentarily and then revert back to the "REQUIRE PIN TO START" screen.

Please record your passcode.

5. To enable your new passcode, use the UP/DOWN toggle buttons to change the flashing "OFF" at bottom of screen to "ON". **If this step is skipped, P.A.S.S. will not be enabled.**
6. Press the MODE button to re-enter the "OPTIONS" menu. The vehicle will now require passcode entry before next startup.

You can exit the "OPTIONS" menu three different ways.

- Toggle to "EXIT" and press the MODE button.
- Hold the MODE button for a few seconds.
- Do nothing, allowing the system to automatically revert back to the main screen.

NOTICE

If the battery becomes low while the P.A.S.S. system is enabled, the gauge may show "New Vehicle Detected" after the battery has been recharged/replaced. Leave the key in the ON position to allow system reconfirmation.

DISABLE P.A.S.S.

1. Press and hold the MODE button to enter the "OPTIONS" menu.
2. Use the UP/DOWN toggle buttons to cycle through options until "REQUIRE PIN TO START" appears. Press the MODE button to select.
3. Enter current passcode.
4. Use the UP/DOWN toggle buttons to change the flashing "ON" at bottom of screen to "OFF".
5. Press the MODE button to re-enter the "OPTIONS" menu. P.A.S.S. is now disabled.

You can exit the "OPTIONS" menu three different ways.

- Toggle to "EXIT" and press the MODE button.
- Hold the MODE button for a few seconds.
- Do nothing, allowing the system to automatically revert back to the main screen.

DIAGNOSTIC TROUBLE CODES

The error screen displays only when the Advanced Warning Light (AWL) indicator is on or when it goes on and off during one startup cycle. Error codes are not stored. When the key switch is in the OFF position, the code and message is lost but will reappear if the fault reoccurs after restarting the vehicle.

Code definitions can be referenced on page 130.

If the Malfunction Indicator Light (MIL) or the EPS lamp illuminates, retrieve the active error codes from the display.

- ① Failure Mode Indicator (FMI)
- ② Suspect Parameter Number (SPN)
- ③ Code Count



1. Press and hold the MODE button to enter the settings menu.
2. Press either toggle button to cycle to the “DIAGCODE” option. Press MODE to select.
3. More than one diagnostic code may be present. Press the toggle UP button to see if more codes are present. Press MODE to select a code.

NOTICE

If the displayed code is an engine fault code, the CHECK ENGINE lamp will blink. If the displayed code is an EPS fault code, the EPS lamp will blink.

4. Record the three (3) numbers displayed.
5. Press MODE to exit to the settings menu.

RIDE COMMAND DISPLAY (IF EQUIPPED)

RIDE COMMAND USER'S GUIDE

Scan the QR Code® to access the Ride Command User's Guide. You will find up-to-date instructions for your Ride Command display's features, including Ride Command+. For more information regarding renewal of your vehicle's Ride Command+ service, visit offroad.polaris.com.



BEFORE YOU RIDE

WARNING

Failure to pay attention to operating your vehicle could result in loss of control, injury, or death. Always concentrate on riding. Do not enter information while operating your vehicle. Some features are limited when vehicle is in motion.

Before riding with your new display, do the following:

- Download the Polaris RIDE COMMAND App from the Apple®/Google Play® store and create your personalized account.
- Check your display to ensure you have the appropriate maps and trails visible for your area. To change or update maps/trails see page 87.
- Trails change often, and the trail data file is only considered valid for 90 days after the release date. Please keep your trail data up to date. Download the latest trails at <http://ridecommand.polaris.com>.

VEHICLE-TO-VEHICLE COMMUNICATION (V2V)

IMPORTANT

For applications that use vehicle-to-vehicle (V2V) communication, radio transmitter IC: 5966A-P001 has been approved by Innovation, Science and Economic Development Canada (ISED) to operate with the Polaris antenna (part number 4018713) with gain of 3 dBi. Any antenna that has a gain greater than 3 dBi is prohibited for use with this device.

DEVICE OPERATING REQUIREMENTS

Phone functionality is dependent on the capabilities of your cell phone.

NOTICE

Some cell phones or operating systems will not work as shown in this manual.

FCC COMPLIANCE STATEMENT

This equipment has been tested and found to comply with the limits for a Class B digital device, pursuant to part 15 of the FCC Rules. These limits are designed to provide reasonable protection against harmful interference in a residential installation. This equipment generates, uses and can radiate radio frequency energy and, if not installed and used in accordance with the instructions, may cause harmful interference to radio communications. However, there is no guarantee that interference will not occur in a particular installation. If this equipment does cause harmful interference to radio or television reception, which can be determined by turning the equipment off and on, the user is encouraged to try to correct the interference by one or more of the following measures:

- Reorient or relocate the receiving antenna.
- Increase the separation between the equipment and receiver.
- Connect the equipment into an outlet on a circuit different from that to which the receiver is connected.
- Consult the dealer or an experienced radio/TV technician for help.

This device complies with FCC RF radiation exposure limits for general population.

DEVICE COMPLIANCE STATEMENTS

USA RADIO COMPLIANCE

This vehicle contains the following radio equipment or components that contain radio equipment:

COMPONENT	COMPONENT ID	MANUFACTURER
9200 Series Display	2AOW7-P001 Z64-2564N Z64-WL18DBMOD	Polaris Inc.
Polaris Plug-in Dongle	2AHPN-HSA-20NP-PB	Harman International Industries

This device complies with part 15 of the FCC Rules. Operation is subject to the following two conditions: (1) This device may not cause harmful interference, and (2) this device must accept any interference received, including interference that may cause undesired operation.

NOTICE

Changes or modifications not expressly approved by the party responsible for compliance could void the user's authority to operate the equipment.

CANADA RADIO COMPLIANCE

This vehicle contains the following radio equipment or components that contain radio equipment:

COMPONENT	COMPONENT ID	MANUFACTURER
9200 Series Display	5966A-P001 4511-2564N 4511-WL18DBMOD	Polaris Inc.
Polaris Plug-in Dongle	6434C-HSA20NPPB	Harman International Industries

This device contains license-exempt transmitter(s)/receiver(s) that comply with Innovation, Science and Economic Development Canada's license-exempt RSS (s). Operation is subject to the following two conditions:

1. This device may not cause interference.
2. This device must accept any interference, including interference that may cause undesired operation of the device.

RIDE COMMAND DISPLAY (IF EQUIPPED)

IMPORTANT

For applications that use vehicle-to-vehicle (V2V) communication, radio transmitter IC 5966A-P001 has been approved by Innovation, Science and Economic Development Canada (ISED) to operate with Polaris antenna (part number 4019300) with gain of 3 dBi. Any antenna that has a gain greater than 3 dBi is prohibited for use with this device.

Pour satisfaire aux exigences en matière d'exposition aux champs RF, cet appareil et ses antennes doivent fonctionner à une distance d'au moins 20 cm de toute personne.

Cet appareil contient des émetteurs/récepteurs exempts de licence qui sont conformes aux CNR exempts de licence d'Innovation, Sciences et Développement économique Canada. Le fonctionnement est sujet aux deux conditions suivantes:

1. L'appareil ne doit pas produire de brouillage.
2. L'appareil doit accepter tout brouillage radioélectrique subi, même si le brouillage est susceptible d'en compromettre le fonctionnement.

IMPORTANT

Pour des applications qui utilisent la communication de véhicule-à-véhicule (V2V), l'IC de l'émetteur radio IC 5966A—P001 a reçu l'autorisation d'Innovation, Sciences et Développement économique Canada (ISED) d'utiliser l'antenne Polaris (numéro de pièce 4019300) avec un gain de 3 dBi. Il est interdit d'utiliser une antenne présentant un gain supérieur à 3 dBi avec cet appareil.

EUROPEAN UNION (EU) RADIO COMPLIANCE

This vehicle contains the following radio equipment or components that contain radio equipment:

Component	9200 Series Display
Component ID	RC-7
Manufacturer	Polaris Inc.
*Transmitting Frequency	2402 - 2480 MHz
Max RF Transmitting PWR	0.2432 W
*Other transmitting radio frequencies may exist outside of EU markets.	

RIDE COMMAND DISPLAY (IF EQUIPPED)

Hereby, Polaris Industries Inc. declares that the above radio equipment is in compliance with Directive 2014/53/EU.

The full text of the EU declaration of conformity is available at the following internet address:

<https://www.polaris.com/en-us/radio-conformity/>

RIDE COMMAND DISPLAY (IF EQUIPPED)

OVERVIEW



① Ride Command Buttons

② Driveline Mode

③ Widgets



④ Settings

⑤ Icon Bar





⑥ Speedometer/Tachometer

⑦ Gear Status

RIDE COMMAND BUTTONS

BUTTON	DESCRIPTION	FUNCTION
	Menu Button	Press the Menu button to access the settings. To reboot the display, press and hold for 5 seconds.
	Gauge Screen Button	Press the Gauge Screen button to select from available screens.

RIDE COMMAND DISPLAY (IF EQUIPPED)

BUTTON	DESCRIPTION	FUNCTION
	Map Button	Press the Map button to access the map, manage your rides and waypoints, and to see your friends on the map with Group Ride.
	Phone Button	Press the Phone button to access your Bluetooth® connected phone, including recent calls, contacts, dialer, and messages.
	Audio Button	Press the Audio button to access the Radio, Weather, USB, and connected Bluetooth® music interface
	Volume Decrease Button	Press the Volume Decrease button to decrease the volume. Press and hold to mute volume.
	Volume Increase Button	Press the Volume Increase button to increase the volume.

RIDE COMMAND DISPLAY (IF EQUIPPED)

PIN ACTIVATED SECURITY SYSTEM (P.A.S.S.) (IF EQUIPPED) — RIDE COMMAND

The optional PIN Activated Security System (P.A.S.S.) is to prevent unauthorized use. When enabled, the vehicle cannot be operated until a valid passcode has been entered using the Ride Command display screen.

ENABLE P.A.S.S.

NOTICE

After activating P.A.S.S. for the first time you must power down the vehicle and allow the electronic control module (ECM) to fully shutdown before restarting. This may take up to three minutes.

1. Go to the settings menu by pressing the Menu button.
2. Select Vehicle Settings from the left toolbar.
3. Select Key Switch Lockout.
4. If this your first time activating P.A.S.S. you will be prompted to enter a new passcode. Enter and verify new passcode.
Please record your passcode.
5. Turn Key Switch Lockout from No to Yes.
6. Turn off the vehicle using the key switch.



NOTICE

If the battery becomes low while the P.A.S.S. system is enabled, the gauge may show "New Vehicle Detected" after the battery has been recharged/replaced. Leave the key in the ON position to allow system reconfirmation.

DISABLE P.A.S.S.

1. Go to the settings menu by pressing the Menu button.
2. Select Vehicle Settings from the left toolbar.
3. Select Key Switch Lockout.
4. Enter passcode to disable P.A.S.S.
5. Turn Key Switch Lockout from Yes to No.

DRIVELINE MODE

ICON	DRIVELINE MODE	DESCRIPTION
	<p>All Wheel Drive (AWD)</p>	<p>When in All-Wheel Drive, the front drive/differential is engaged. This state will apply torque when rear wheel slip is detected. The locked state will increase steering effort and changes the handling characteristics from the 2WD mode. If switched to AWD Lock when vehicle speed, accelerator pedal position, and engine RPM are above activation limits, AWD Lock will not engage until vehicle speed, accelerator pedal position, and engine RPM are decreased.</p>
	<p>Two Wheel Drive (2WD) Locked</p>	<p>Operating in 2WD will lock the rear differential, meaning both rear wheels are powered. In 2WD, both rear wheels will rotate at the same speed. Using 2WD in slippery or low traction conditions helps improve traction when AWD may not be required.</p>
	<p>Differential Unlock (TURF mode)</p>	<p>Operating in Turf Mode unlocks the rear differential and divides power flow between the left and right wheels, while allowing them to rotate at different speeds during cornering where the outside wheel needs to travel further than the inside wheel. This prevents axle torque wind-up that damages the turf. Both wheels will drive with equal torque, but this torque magnitude is limited to the tractive torque available at the wheel with the least traction. For example, if one tire is off the ground and has no traction, all power will flow to that wheel (path of least resistance) causing it to accelerate and spin. No driving torque will go to the other wheel with traction.</p>

RIDE COMMAND DISPLAY (IF EQUIPPED)

ICON BAR

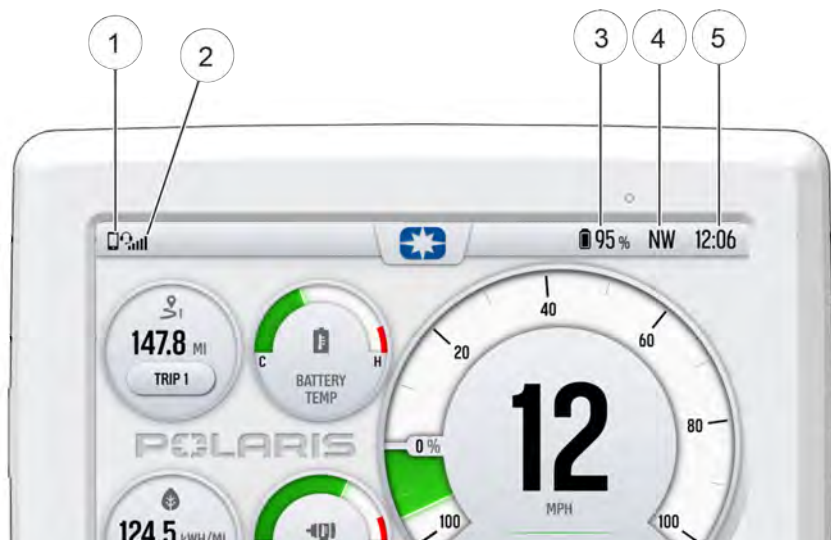

ICON	DESCRIPTION	FUNCTION
①	Headset	Displays icon if headset is connected
②	Signal Strength	Displays current cell signal strength
③	Charge Level	Displays current charge capacity percentage
④	Vehicle Direction	Displays vehicle direction
⑤	Clock	Displays current time

GAUGE SCREENS

Press the Gauge Screen button to toggle between gauge screens. The display comes loaded with two different gauge screens. Additional gauge screens can be added or deleted.

Each gauge screen is customizable and can be set up in the following configurations:

- Four round widgets
- Two round widgets and a list of three data values
- A list of five data values

To customize your gauge screens, press the gear icon located in the lower right corner of the display.



SETTINGS

From the setting menu you can view vehicle information, manage Bluetooth® devices, update display software, and more.

To access the Setting menu, press the Menu button ①.

You can also navigate to the settings menu by pressing the Polaris logo at the top of the display screen ②. This will open the Control Panel. From the Control Panel, select the settings tab, then press the **All Settings** button located in the lower right corner of the display screen.



RIDE COMMAND DISPLAY (IF EQUIPPED)

DISPLAY MODE

From the Menu settings, select the display mode from the available options.

The display mode can be set to Day, Night, or AUTO mode.

Day Mode



Night Mode



USB CABLE LOCATION

For managing updates via USB flash drive, the USB cable is located in the glove box.

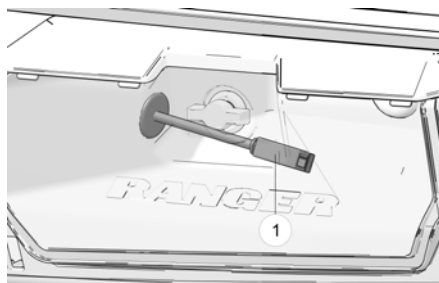

UPDATE SOFTWARE

NOTICE

Before updating the Display, always export your existing rides and waypoints to a USB drive to avoid losing them.

To update the software, do the following:

ON YOUR PERSONAL COMPUTER

1. Go to ridecommand.polaris.com/update.
2. Log into your account, or create a new account.
3. Using the Vehicle Identification Number (VIN), add your new Polaris vehicle to your Garage.
4. Locate and download the latest software to a USB flash drive (8+ GB).

ON YOUR VEHICLE

1. Connect the USB flash drive to the USB cable and power up your vehicle.
2. On the RIDE COMMAND display, select the Settings menu on your display by pressing the POLARIS icon at the top of the screen.
3. Select General Settings, then Update Software.
4. Select the file you wish to load (use date listed in the file name to determine most recent file).
5. Select Yes to restart display (restart required).

ERROR MESSAGES

If an error occurs while updating your software, perform one or all of the following actions to resolve the issue:

1. Remove and reconnect the USB flash drive securely.
2. Make sure the display files are not inside a folder on the flash drive.
3. Make sure only display files are on the flash drive. Remove any other files if necessary.
4. Try using a different USB flash drive.

UPDATE MAPS

To update the maps on your display, do the following:

1. Go to ridecommand.polaris.com/update and download the map update to a USB flash drive.
2. Insert USB flash drive into the USB port on your vehicle.
3. Press the Update maps in the General Settings.
4. Select the file you want to install by pressing the corresponding down arrow icon.
5. This will update the display's map which will automatically restart the display once the update is complete. Do not remove the USB flash drive until the display has fully restarted.

USB HARDWARE

SOFTWARE UPDATES

For software update, POLARIS recommends using a SanDisk® or similar USB flash drive with a minimum of 4GB in available memory, formatted using the FAT32 or exFAT® file systems. For best results remove all files from the flash drive before starting the update process.

RIDE COMMAND DISPLAY (IF EQUIPPED)

MAP UPDATES

For Map updates, a 32GB USB drive is required (USB 3.0 drive is highly recommended) USB drive must be formatted to exFAT® before copying the map file onto it.

TRAIL UPDATES

For Trail updates, a 4GB drive formatted to FAT32 can be used.

RIDE COMMAND+ (IF EQUIPPED)

Your vehicle may come equipped with RIDE COMMAND+ technology, which gives you access to your vehicle's custom information including Vehicle Health, Vehicle Locator and Issue Diagnostics along with a variety of features via the Polaris mobile app. You will need a cellular connection to view these features.

To learn more about RIDE COMMAND+, including equipped or compatible vehicles, specific features, and to access the RIDE COMMAND+ User Guide, visit ridecommand.polaris.com/ridecommand+ or scan the QR code below:



Disclaimer: RIDE COMMAND+ only available in North America.

OPERATION

VEHICLE BREAK-IN

BRAKE SYSTEM BREAK-IN

Apply only moderate braking force for the first 50 stops. Aggressive or overly forceful braking when the brake system is new could damage brake pads and rotors.

OPERATING GUIDELINES

POWERING THE VEHICLE

1. Sit in the driver's seat and fasten the seat belt. Always make sure all cab nets are closed and latched when riding in this vehicle. Do not press the accelerator pedal while starting the vehicle.
2. Shift the gear selector to PARK (P) position.
3. Insert the key and turn the key switch to the ON position.
4. Press the Direction Selector Switch in the FORWARD (F) position to go forward or the REVERSE (R) position to go rearward. Always check the position of the Direction Selector Switch (F/R) before pressing the accelerator pedal.
5. Shift the gear selector to either HIGH (H) or LOW (L) gear.
6. Press the accelerator pedal to move the vehicle.

BRAKING

1. Release the accelerator pedal completely.
2. Press on the brake pedal evenly and firmly.
3. Practice starting and stopping (using the brakes) until you're familiar with the controls.

NOTE
See page 46 for details on the regenerative braking system and its effect on vehicle driving range.

OPERATION

DRIVING IN REVERSE

 WARNING

Before switching to reverse, use extra care to make sure the area is clear of people or obstacles. When it's safe to proceed, back slowly.

Follow these precautions when operating in reverse:

1. Always check for obstacles or people behind the vehicle.
2. Apply pressure to the accelerator pedal *lightly*. Do not press the accelerator pedal suddenly.
3. Back slowly.
4. Apply the brakes *lightly* for stopping.
5. Avoid making sharp turns.

STOPPING THE MOTOR AND PARKING THE VEHICLE

 WARNING

When leaving the vehicle on an incline is unavoidable, use extra care. Vehicle rollaway can cause serious injury or death. This vehicle can roll whenever the gear selector is not in the PARK (P) position. Always shift to PARK (P) when stopping the motor or leaving the vehicle. If leaving the vehicle unattended, block the rear wheels on the downhill side and keep children, pets, and others away from the gear selector.

To park the vehicle:

1. Stop the vehicle on a level surface.
2. Place the transmission in PARK (P). This vehicle can roll whenever the transmission is not in the PARK (P) position.
3. Stop the motor by turning the Key Switch from the ON position to the OFF position..
4. Engage the park brake (if equipped).
5. Remove the key to prevent unauthorized use.

LOW-CHARGE OPERATION

When the high-voltage battery pack reaches 20-25% remaining charge, the vehicle will display LOW CHARGE on the instrument cluster. As the battery pack discharges to a lower remaining charge (e.g. 5%), vehicle performance may gradually decrease in order to conserve power. There will be less available power and torque while operating with low charge.

NOTE

When the vehicle has a low charge, avoid driving at fast speeds or aggressive acceleration to maximize remaining range.

MAINTENANCE

ELEVATING THE VEHICLE FOR SERVICE

 **WARNING**

Improperly jacking or supporting the vehicle can result in the vehicle falling or tipping, which can lead to serious injury or death. When elevating vehicle:

- Move vehicle to a firm level surface.
- Shift to PARK (P).
- Do not leave engine running.
- Prevent the vehicle from moving by chocking the wheels. A chock is a wedge or wheel stop that is designed to keep the vehicle from moving forward or backward and falling off the jack. If jacking the FRONT of the vehicle, then chock front and rear sides of both REAR tires. If jacking the REAR of the vehicle, then chock front and rear sides of both FRONT tires.
- Keep bystanders away and make sure no occupants or cargo are still in the vehicle.
- Use a jack designed for a high ground clearance off-road vehicle (such as the POLARIS Off-Road Utility Jack).
- Follow the jack manufacturer's instructions.
- Do not place any object above or under a jack.
- After lifting vehicle with a jack, never place any part of your body under the vehicle without first properly blocking vehicle using designated support points.

MAINTENANCE OVERVIEW

Any qualified repair shop or person may maintain systems on your vehicle. An authorized Polaris dealer can perform any service that may be necessary for your vehicle.

Owners are responsible for performing the scheduled maintenance identified in this owner's manual.

Careful periodic maintenance will help keep your vehicle in the safest, most reliable condition. Inspection, adjustment and lubrication of important components are explained in the periodic maintenance chart.

Inspect, clean, lubricate, adjust and replace parts as necessary. When inspection reveals the need for replacement parts, genuine Polaris parts are available from your Polaris dealer.

Service and adjustments are important for proper vehicle operation. If you're not familiar with safe service and adjustment procedures, a qualified dealer can perform these operations.

MAINTENANCE

Vehicles subjected to heavy or severe use patterns must be inspected and serviced more frequently.

SEVERE USE DEFINITION

- Frequent exposure to mud, water, or sand
- Racing or race-style use
- Sustained operation at high speeds

POLARIS MAINTENANCE SCHEDULE

The intervals shown in this table are based on vehicles operated under normal conditions. Each interval is given in miles (kilometers) or time intervals. Items should be serviced at whichever interval comes first. Continue to reference the following maintenance schedules at the given intervals as miles (kilometers) or time in use increases on the vehicle.

Vehicles subjected to severe use must be serviced at 50% of the stated interval. Examples of Severe Use: Frequent exposure to mud, water, or sand, prolonged high-speed use, prolonged low-speed heavy load operation.

EVERY 1000 MILES (1600 KM)

Vehicle Body	Clean throughout the vehicle using mild soap and water (such as from a garden hose) to remove dirt and/or debris. Caked-on debris like mud should be removed by hand. Do not use high-pressure water. Allow vehicle to dry before operating..
12V Battery	Check terminals; terminals should be tight and free of corrosion. Clean, test, and replace as necessary.
High-voltage Cables	Visually inspect high-voltage cabling (orange color) for damage to insulation, proper routing, and proper retention. If damage is suspected, have vehicle brought immediately to an authorized dealer.
Front Gearcase Fluid	Change fluid.
Brake System	Inspect for fluid leaks; add lubricant if needed. Inspect brake pad wear.
Wiring	Inspect for wear, routing, and retention.
General Lubrication	Locate all applicable fittings and grease.
Suspension / Steering Components*	Inspect tie rods, wheel bearings, suspension bushings, and ball joints for loose or worn components; replace as needed. Inspect shock absorbers for leaks or damage. Lubricate (if applicable).
Cooling System	Fluid level inspection; inspect for fluid leaks; add coolant if needed. Inspect coolant strength seasonally.

MAINTENANCE

EVERY 1000 MILES (1600 KM)

Transmission Fluid	Change fluid.
Parking Brake (if applicable)	Inspect and adjust as needed.
* It is recommended to have an authorized dealer perform these services.	

Vehicles subjected to severe use must be serviced at 50% of the stated interval. Examples of Severe Use: Frequent exposure to mud, water, or sand, constant high RPM use, prolonged low-speed heavy load operation, extended idle, and short trip cold weather operation.

ADDITIONAL MAINTENANCE INTERVALS

Monthly	Brake Pad Wear	Inspect and replace as needed.
	12V Battery	Check terminals; Test; Clean / Replace as needed.
Every 2000 miles (3200 km) or 24 months	Brake Fluid	Change fluid (DOT 4).
Every 2000 miles (3200 km)	Shock Absorbers*	Replace.
Every 5 years	Cooling System	Replace fluid.
* It is recommended to have an authorized dealer perform these services.		

LUBRICATION RECOMMENDATIONS

Check and lubricate all components at the intervals outlined in the Periodic Maintenance Chart section, or more often under severe use, such as wet or dusty conditions. Items not listed in the chart should be lubricated at the general lubrication interval.

ITEM	LUBE	METHOD
Brake Fluid	DOT 4 Brake Fluid	Maintain level between fill lines. See page 103.
Transmission Gearcase Oil	AGL Gearcase Lubricant	See page 99.
Front Gearcase Oil	Demand Drive Fluid	See page 101.
Prop Shaft	U-Joint Grease	Locate fitting and grease.
Front and Rear Stabilizer Bar Bushings	All Season Grease or grease conforming to NLGI No. 2	Grease one fitting on each side of the vehicle.

Lubrication Points

- ① Prop Shaft
- ② Front Stabilizer Bar (both sides)
- ③ Rear Stabilizer Bar (both sides)

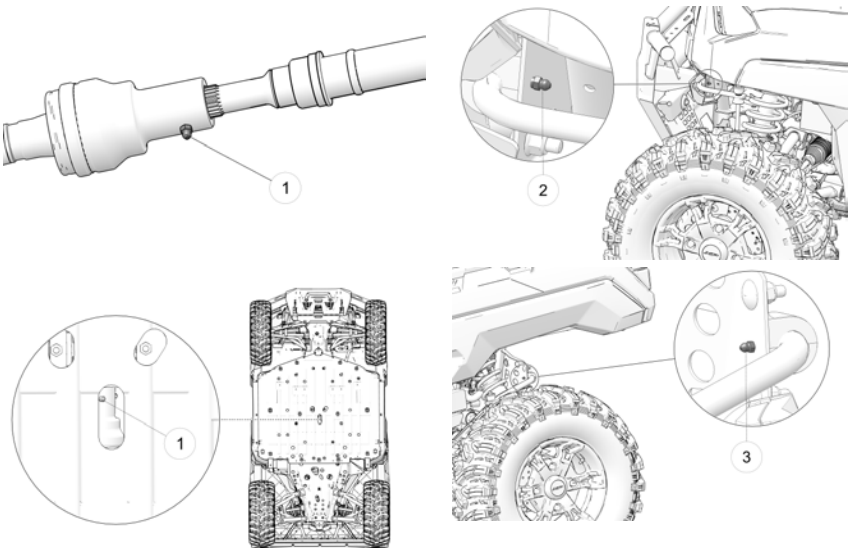

MAINTENANCE

GEARCASES

GEARCASE SPECIFICATION CHART

GEARCASE	LUBRICANT	CAPACITY	FILL PLUG TORQUE	DRAIN PLUG/ LEVEL CHECK PLUG TORQUE
Transmission (Main Gearcase)	AGL Gearcase Lubricant & Transmission Fluid	51 oz. (1500 ml)	10-14 ft. lbs. (14-19 Nm)	10-14 ft. lbs. (14-19 Nm)
Demand Drive Unit (Front Gearcase)	Demand Drive Fluid	6.8 oz. (200 ml)	8-10 ft. lbs. (11-13.6 Nm)	11 ft. lbs. (15 Nm)

TRANSMISSION (MAIN GEARCASE)

TRANSMISSION OIL CHECK

Always check and change the transmission oil at the intervals outlined in the Periodic Maintenance Chart. Maintain the oil level even with the bottom thread of the fill plug hole.

The fill plug is located on the rear of the gearcase. Maintain the fluid level at the bottom of the fill plug hole.

To check the transmission fluid, do the following:

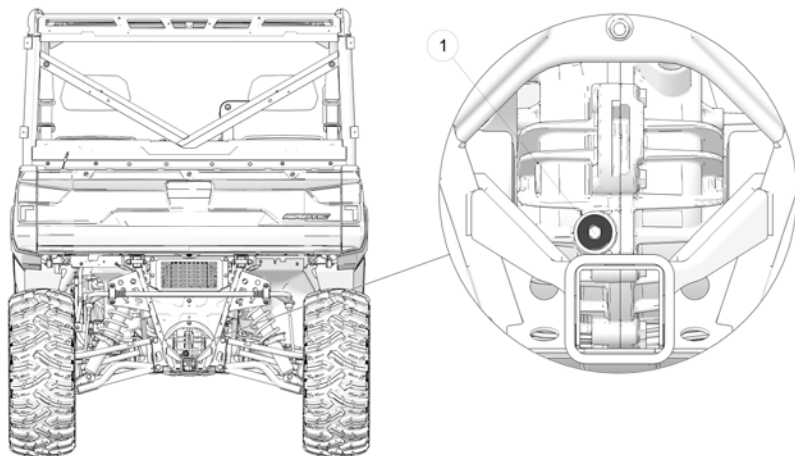

1. Position the vehicle on a level surface.
2. Remove the fill plug ①.
3. Check the fluid level.
4. Add the recommended fluid to the bottom of the fill plug hole. Do not overfill.
5. Reinstall the fill plug. Torque to specification. See the Gearcase Specification Chart section.

MAINTENANCE

TRANSMISSION OIL CHANGE

The drain plug is located on the bottom of the gearcase. Access the drain plug through the hole in the skid plate.

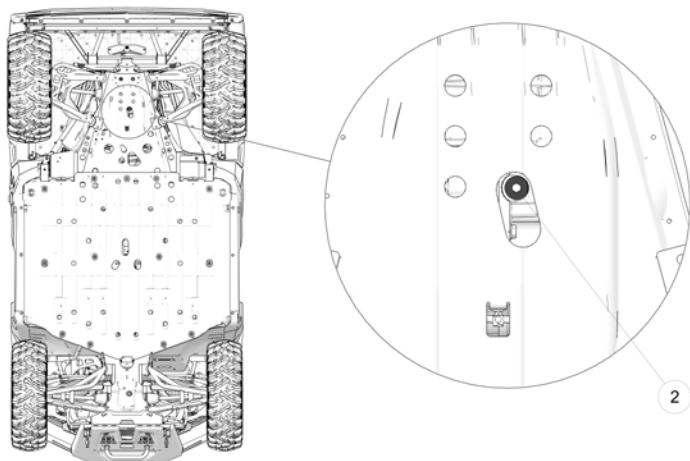

1. Remove the fill plug.
2. Place a drain pan under the drain plug ②.
3. Remove the drain plug. Allow the fluid to drain completely.
4. Clean and reinstall the drain plug. Torque to specification. See the Gearcase Specification Chart section.
5. Add the recommended fluid to the bottom of the fill plug hole. Do not overfill.
6. Reinstall the fill plug. Torque to specification. See the Gearcase Specification Chart section.
7. Check for leaks. Discard used fluid properly.

DEMAND DRIVE (FRONT GEARCASE)

DEMAND DRIVE OIL CHECK

Always check and change the demand drive fluid at the intervals outlined in the Periodic Maintenance Chart. Maintain the oil level even with the bottom thread of the fill plug hole. Refer to the Gearcase Specifications Chart for recommended lubricants, capacities and torque specifications.

The front gearcase fill plug ① is located on the right side of the front gearcase.

1. Position the vehicle on a level surface.
2. Remove the fill plug ①. Check the oil level.
3. Add the recommended oil as needed.
4. Reinstall the fill plug. Torque to specification.

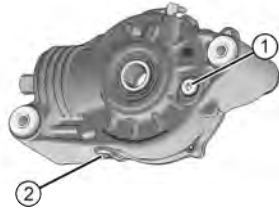

DEMAND DRIVE OIL CHANGE

1. Support the vehicle securely with a jackstand.
2. Remove the front tire on the passenger's side for ease of access (optional).
3. Remove the fill plug.
4. Place a drain pan under the drain plug ② on the bottom right-hand side.
5. Remove the drain plug. Drain the oil.
6. Clean and reinstall the drain plug. Torque to specification.
7. Add the recommended fluid to the bottom of the fill plug hole. Do not overfill.
8. Reinstall the fill plug. Torque to specification.
9. Check for leaks.
10. Discard used oil properly.

RADIATOR COOLANT LEVEL

WARNING

To avoid burns, allow the motor controller and coolant system to cool down before opening the system. Never remove the pressure cap while the motor controller is warm or hot. Escaping steam can cause burns.

The coolant access is located under the cargo box. Check for leaks periodically and add coolant as needed.

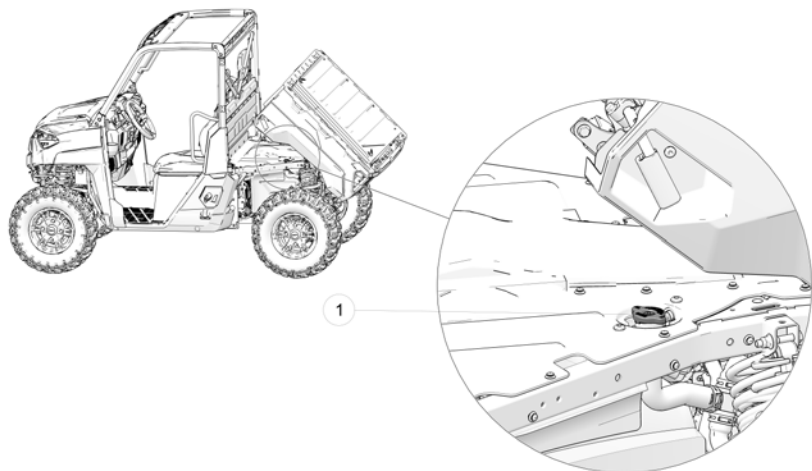

1. Lift the cargo box.
2. Slowly remove the radiator cap ①.
3. View the coolant level through the opening.
4. Use a funnel and slowly add coolant as needed.
5. Reinstall the pressure cap.

BRAKES

The front and rear brakes are hydraulic disc type brakes. Press down on the brake pedal to engage the brakes.

BRAKE FLUID

Inspect the brake system routinely. Inspect the level of the brake fluid before each operation.

WARNING

After opening a bottle of brake fluid, always discard any unused portion. Never store or use a partial bottle. Brake fluid is hygroscopic, meaning it rapidly absorbs moisture from the air. The moisture causes the boiling temperature of the brake fluid to drop, which can lead to early brake fade and the possibility of accident or severe injury.

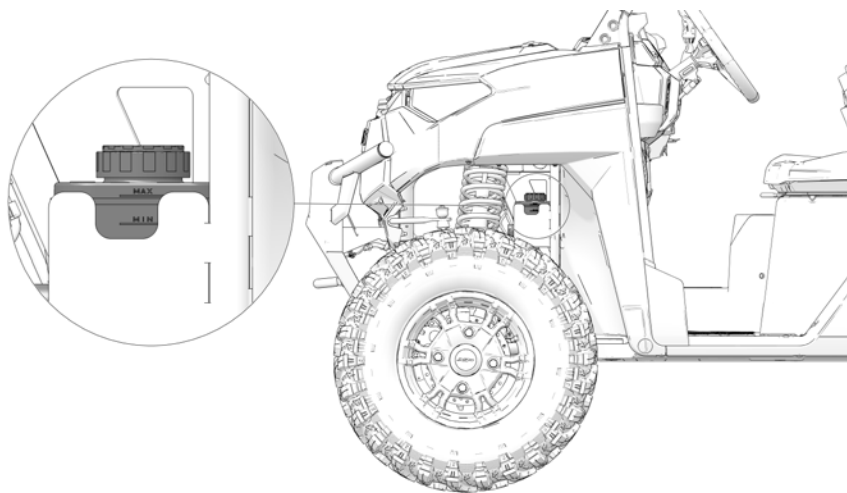

Change the brake fluid every two years and any time the fluid becomes contaminated, the fluid level is below the minimum, or if the type and brand of the fluid in the reservoir are unknown.

1. Position the vehicle on a level surface and turn off the motor.
2. View the brake fluid level at the reservoir in the driver's side wheel well. The level should be between the upper (MAX) and lower (MIN) level lines.
3. If the fluid level is lower than the upper level line, open the hood and add brake fluid to the upper (MAX) line.
4. Apply the brake forcefully for a few seconds and check for fluid leakage around the fittings.

MAINTENANCE

BRAKE INSPECTION

WARNING

Do not apply WD-40® or any petroleum product to brake discs. These types of products are flammable and may also reduce the friction between the brake pad and caliper.

1. Check the brake system for fluid leaks.
2. Check the brake pedal for excessive travel or a spongy feel.
3. Check the friction pads for wear, damage and looseness.
4. Check brake discs for signs of cracks, excessive corrosion, warping or other damage. Clean any grease using an approved brake cleaner or alcohol.
5. Inspect the brake disc spline and pad wear surface  for excessive wear. Change pads when worn to 0.030 in (0.762 mm).

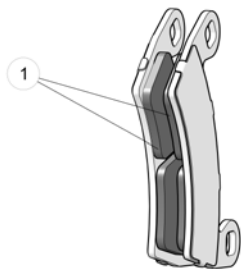

STEERING WHEEL INSPECTION

Check the steering wheel for specified freeplay and smooth operation at the intervals outlined in the Periodic Maintenance Chart section.

1. Position the vehicle on level ground.
2. Lightly turn the steering wheel left and right.
3. There should be 0.8-1.0 in (20-25 mm) of freeplay.
4. If there is excessive freeplay or strange noises, or the steering feels rough or “catchy,” have the steering system inspected by an authorized dealer.

SUSPENSION ADJUSTMENT

NOTICE

The front and rear shocks are located in a fixed position on the vehicle frame. No other adjustment to shock position should be attempted.

CAM ADJUSTMENT

Adjust the front and rear shock absorber springs by rotating the adjustment cam either clockwise or counter-clockwise to increase or decrease spring tension.

① Stiffest Setting

② Softest Setting

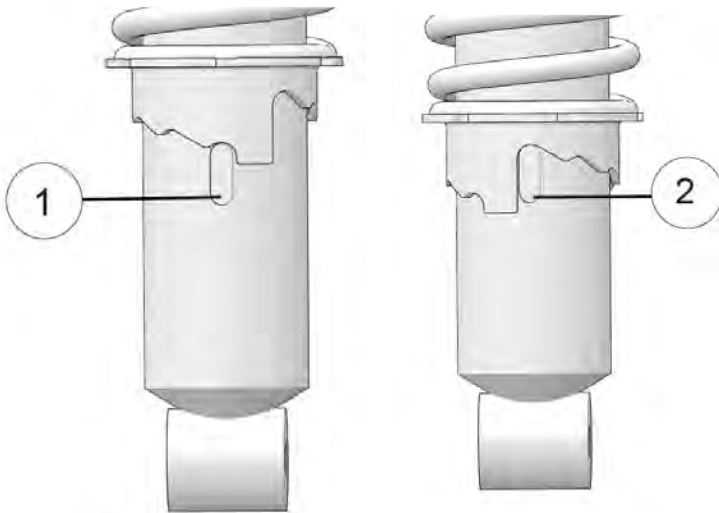

Always heed the following rules if you make adjustments to this suspension.

- Always return the suspension to the lowest (softest) setting after the load is removed from the vehicle. The increased suspension height will negatively impact vehicle stability when operating without a load.
- Always apply the same adjustment setting to both rear wheels.

MAINTENANCE

TIRES

WARNING

Operating your vehicle with worn tires will increase the possibility of skidding, loss of control and an accident, which could result in serious injury or death.

Always replace tires when the tread depth measures 1/8 in (3 mm) or less.

Improper tire inflation or the use of non-standard size or type of tires may adversely affect vehicle handling, which could result in vehicle damage or personal injury. Always maintain proper tire pressure. Always use POLARIS approved size and type of tires for this vehicle when replacing tires.

TIRE TREAD DEPTH

Always replace tires when tread depth is worn to 3 mm (1/8") or less.

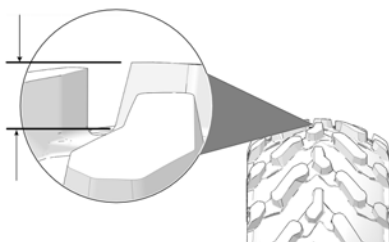

AXLE AND WHEEL NUT TORQUE SPECIFICATIONS

Inspect the following items occasionally for tightness, and if they've been loosened for maintenance service. Do not lubricate the stud or the lug nut.

Lug Nut (Aluminum Wheels)		Front and Rear	120 ft-lbs (163 Nm)
Spindle Nut		Front	180 ft. lbs. (245 N-m)
Hub Retaining Nut		Rear	180 ft. lbs. (245 N-m)

WHEEL REMOVAL

1. Position the vehicle on a level surface.
2. Apply the brakes. Set the park brake. Turn the key off.
3. Loosen the wheel nuts slightly.

4. Elevate the side of the vehicle by placing a suitable stand under the frame.
5. Remove the wheel nuts. Remove the wheel.

WHEEL INSTALLATION

 **WARNING**

Improperly installed wheels can adversely affect tire wear and vehicle handling, which can result in serious injury or death. Always ensure that all nuts are torqued to specification. Do not service axle nuts that have a cotter pin installed. Your dealer can assist.

1. Place the transmission in PARK.
2. Place the wheel on the hub with the valve stem toward the outside and rotation arrows on the tire pointing toward forward rotation.
3. Attach the wheel nuts and finger-tighten.
4. Carefully lower the vehicle to the ground.
5. Torque the wheel nuts to specification.

DISCONNECTING HIGH VOLTAGE POWER

The high-voltage service disconnect ① is located under the passenger-side seat. Lift the seat up and remove the storage bin to access the harness.

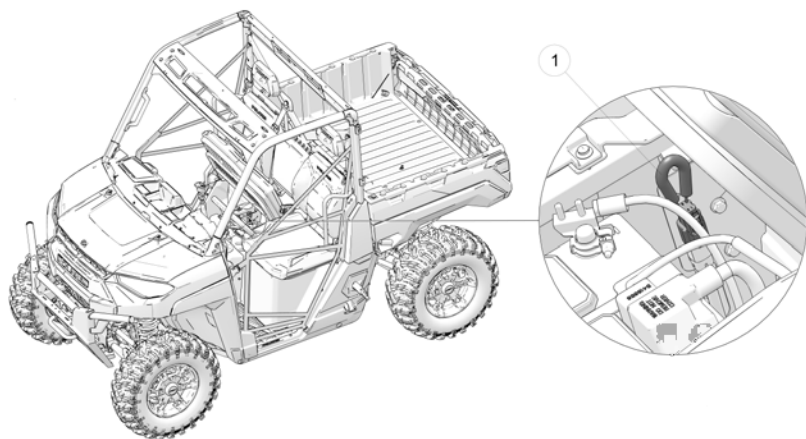

IMPORTANT

To remove the high-voltage service disconnect, grasp the connector by the plastic base. Do not pull the wire loop on top of the service disconnect.



Slide the lock tab ② up, pinch the secondary lock, and then pull the plastic housing from the harness. Reattach the housing to the harness and push the lock tab down when you have finished servicing the 12V battery to resume driving.

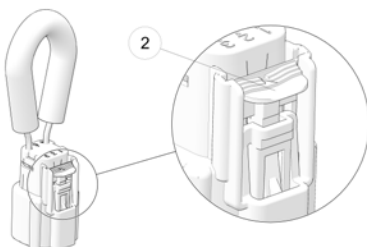

12V BATTERY MAINTENANCE AND CHARGING

WARNING

Battery electrolyte is poisonous. It contains sulfuric acid. Serious burns can result from contact with skin, eyes or clothing.

Antidote:

External: Flush with water.

Internal: Drink large quantities of water or milk. Follow with milk of magnesia, beaten egg, or vegetable oil. Call physician immediately.

Eyes: Flush with water for 15 minutes and get prompt medical attention.

Batteries produce explosive gases. Keep sparks, flame, cigarettes, etc. away. Ventilate when charging or using in an enclosed space. Always shield eyes when working near batteries. **KEEP OUT OF REACH OF CHILDREN.**

Before servicing your vehicle's 12V battery, **ALWAYS** power off the vehicle and remove the key from the key switch. Then, ensure that high-voltage power is turned off by unclasp the high-voltage service disconnect.

Your vehicle has a low-maintenance flooded battery. It does not require refilling.

Always keep battery terminals and connections free of corrosion. If cleaning is necessary, remove the corrosion with a stiff wire brush. Wash with a solution of one tablespoon baking soda and one cup water. Rinse well with tap water and dry off with clean shop towels. Coat the terminals with dielectric grease or petroleum jelly. Be careful not to allow cleaning solution or tap water into a conventional battery.

The sealed battery is already filled with electrolyte and has been sealed and *fully charged* at the factory. *Never* pry the sealing strip off or add any other fluid to this battery.

Your electric vehicle will maintain the charge of the 12V battery whenever the High-Voltage Battery Pack has an adequate State of Charge (SoC). See page 117 for details on long-term vehicle storage.

12V BATTERY REMOVAL

WARNING

Improperly connecting or disconnecting battery cables can result in an explosion and cause serious injury or death. When removing the battery, always disconnect the negative (black) cable first. When reinstalling the battery, always connect the negative (black) cable last.

To remove the battery, do the following:

MAINTENANCE

1. Power off the vehicle and remove the key from the key switch.
2. Lift up the passenger-side seat and remove the storage bin.
3. Remove the high-voltage service disconnect loop. See page 108 for details.
4. Disconnect the black (-) battery cable first. Disconnect the red (+) battery cable last.
5. Remove the battery hold-down strap.
6. Lift the battery out of the vehicle.

NOTICE

If electrolyte spills, immediately wash it off with a solution of one tablespoon baking soda and one cup water to prevent damage to the vehicle.

12V BATTERY INSTALLATION

1. Ensure that the battery is fully charged.
2. Place the battery in the battery holder.
3. Coat the terminals with dielectric grease or petroleum jelly.
4. Connect and tighten the red (positive) cable first.
5. Connect and tighten the black (negative) cable last.
6. Install the battery hold-down strap and tighten the screws.
7. Verify that cables are properly routed.
8. Reconnect the high-voltage service disconnect loop. See page 108 for details.
9. Reinstall the seat and storage bin.

FUSES

If the motor stops or will not start, or if you experience other electrical failures, a fuse may need replacement. Locate and correct any short circuits that may have caused the blown fuse, then replace the fuse. To access the fuse box, lift the passenger-side seat up and remove the storage bin under the seat. Spare fuses are provided in the fuse box. If you suspect that a fuse or relay may not be working properly, your dealer can assist.

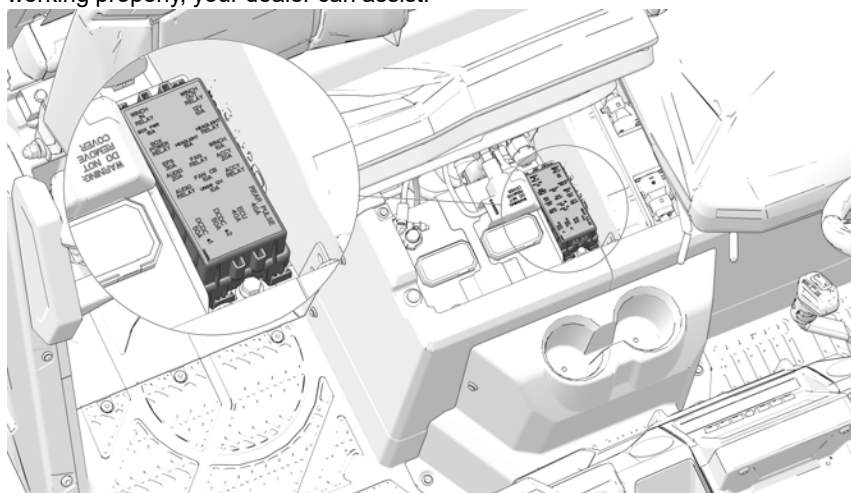

RANGER XP KINETIC

FUSE SIZE	FEATURE SUPPORTED
40A	Rear Pulse Bar
40A	ECU
50A	DCDC Converter (#1)
50A	DCDC Converter (#2)
15A	Box Power
10A	12V Accessory
15A	Headlight
30A	EPS
10A	Winch
20A	Audio

MAINTENANCE

FUSE SIZE	FEATURE SUPPORTED
20A	Accessory
10A	Fan Circuit Breaker
10A	UNSW 12V

LIGHTS

Poor lighting can result in reduced visibility when driving. Headlight and taillight lenses become dirty during normal operation. Clean lights frequently and replace failed (or failing) lights promptly. Do not operate this vehicle at night or in low light conditions until the headlight is replaced. Always make sure lights are adjusted properly for best visibility.

The vehicle is equipped with integrated LED lights. In the event of a failure, the entire assembly^① must be replaced.

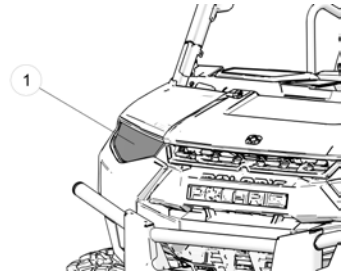

HEADLIGHT BEAM ADJUSTMENT

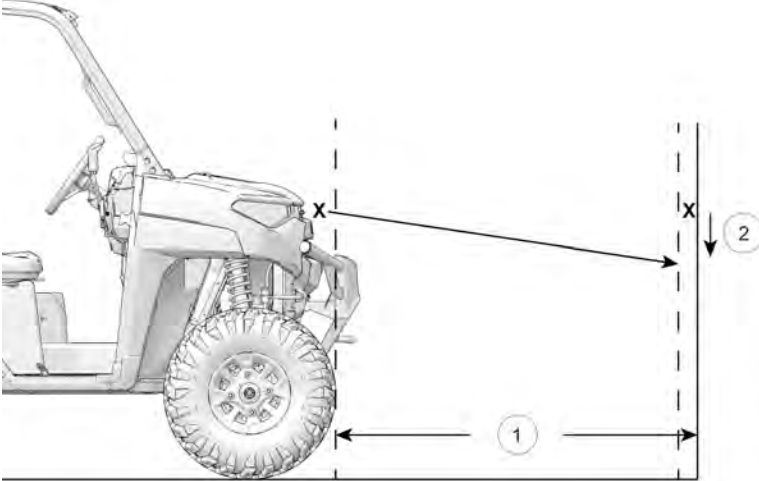

① 25 ft. (7.6 M)

② 8 in. (20 cm)

To adjust the headlight beam, do the following:

1. Ensure the tire pressure of all tires is at recommended levels.
2. Place the vehicle on a level surface with the headlight approximately 25 ft. (7.6 m) from a dark wall.

MAINTENANCE

3. Measure the distance from the floor to the center of the headlight and make a mark on the wall at the same height.
4. Apply the brakes. Turn the key switch to ON position. Turn on the low-beam headlights.
5. Observe the headlight aim. The most intense part of the headlight beam should be aimed 8" (20 cm) below the mark placed on the wall. Include the weight of a rider on the seat while performing this step.
6. If a headlight needs adjustment, locate the three adjustment screws at the back of each headlight (one on top, two on the bottom).
7. Rotate the adjustment screw to adjust the headlight as needed.

BRAKE LIGHTS

When the brake pedal is depressed, the brake light comes on. Check the brake light before each ride.

To check the brake lights, do the following:

1. Turn the key to the ON position.
2. Depress the brake pedal. The brake light should come on after about 0.4 in (10 mm) of pedal travel. If the light doesn't come on, check the bulb.

CLEANING AND STORAGE

WASHING THE VEHICLE

Keeping your POLARIS vehicle clean will not only improve its appearance but it can also extend the life of various components.

NOTICE

High water pressure may damage components. POLARIS recommends washing the vehicle by hand or with a garden hose, using mild soap.

NOTICE

Certain products, including insect repellents and chemicals, will damage plastic surfaces. Do not allow these types of products to contact the vehicle.

The best and safest way to clean your POLARIS vehicle is with a garden hose and a pail of mild soap and water.

1. Use a professional-type washing cloth, cleaning the upper body first and the lower parts last.
2. Rinse with clean water frequently.
3. Dry surfaces with a chamois to prevent water spots.

WASHING TIPS

- Avoid the use of harsh cleaners, which can scratch the finish.
- Do not use medium to heavy duty compounds on the finish.
- Always use clean cloths and pads for cleaning and polishing. Old or reused cloths and pads may contain dirt particles that will scratch the finish.
- Grease all zerk fittings immediately after washing.

If a high pressure water system is used for cleaning, exercise extreme caution. The maximum pressure should not exceed 4000 PSI, 2.5 GPM with a 40° pressure washer nozzle. Make sure to keep the pressure washer nozzle 23.6 in (60 cm) from the vehicle. The water may damage components and could remove paint and labels. Avoid directing the water stream at the following items:

- EVSE charge port
- High-voltage battery pack
- DC-DC converter
- Motor
- Motor control unit
- Onboard charger
- High Voltage Cables/ Battery
- Wheel Bearings
- Main gearcase seals
- Brakes
- Labels and decals
- Switches and controls
- Electrical components and wiring
- Cab and body panels

MAINTENANCE

If an informational or graphic label becomes illegible or comes off, contact your authorized POLARIS dealer, or other qualified person, to obtain a replacement. Replacement safety labels are provided by POLARIS at no charge.

POLISHING THE VEHICLE

POLARIS recommends the use of common household aerosol furniture polish for polishing the finish on your POLARIS vehicle. Follow the instructions on the container.

POLISHING TIPS

- Avoid the use of automotive products, some of which can scratch the finish of your vehicle.
- Always use clean cloths and pads for cleaning and polishing. Old or reused cloths and pads may contain dirt particles that will scratch the finish.

STORING THE VEHICLE

Any time the vehicle will be parked for more than a few days, follow the recommended storage procedures:

1. Make any necessary repairs and clean the vehicle.
2. Store the vehicle out of the sun in a cool, dry place.
3. Be sure the storage area is well ventilated.
4. Turn the key off.
5. *DO NOT* set the park brake (if equipped).
6. Verify that tire pressure is at specification.
7. Block the wheels to prevent rolling.
8. Ensure the high-voltage battery pack(s) have a State of Charge (SoC) of 60%. See page 47 for details.

MAINTENANCE

STORAGE TIPS

CLEAN THE EXTERIOR

Make any necessary repairs and clean the vehicle as recommended.

FLUID LEVELS

Inspect the fluid levels. Add or change fluids as recommended in the Periodic Maintenance Chart.

- Demand drive fluid (front gearcase)
- Rear gearcase fluid (if equipped)
- Brake fluid (change every two years and any time the fluid looks dark or contaminated)

STORAGE AREA / COVERS

Be sure the storage area is well ventilated. Cover the vehicle with a genuine Polaris cover. Do not use plastic or coated materials. They do not allow enough ventilation to prevent condensation, and may promote corrosion and oxidation.

RODENTS / PESTS

Inspect the vehicle interior periodically to remove accumulated pest or rodent debris, such as nests. Check vehicle wiring for damage caused by chewing.

REMOVAL FROM STORAGE

1. Verify that the high-voltage battery pack is fully charged after the 24-hour charging period. See page 47 for details.
2. Verify that tire pressure is at specification.
3. Perform the pre-ride inspection.
4. Inspect and verify the tightness of the bolts, nuts and other fasteners.
5. Lubricate at the intervals outlined in the Periodic Maintenance Chart.
6. Check for rodent damage or nests in flat spaces between components.

TRANSPORTING THE VEHICLE

 **WARNING**

Cargo and other loose vehicle parts may fly off while transporting this vehicle. Secure or remove all cargo, and inspect the unit for loose parts prior to transport.

If transporting the vehicle in a non-enclosed trailer, then the vehicle must FACE FORWARD, or roof must be removed.

Failure to comply may allow airflow, vibration, or other factors to separate the roof from the vehicle and cause an accident, resulting in serious personal injury or death.

Follow these procedures when transporting the vehicle.

1. Apply the brakes.
2. Place the transmission in PARK. Turn the key switch from the ON position to the OFF position.
3. Slowly release the brake pedal and make sure the transmission is in PARK before exiting the vehicle.
4. Remove the key to prevent loss during transporting.
5. Secure the seat. Ensure that the seat is attached correctly and is not loose.
6. Using suitable straps or rope, always secure the vehicle to the trailer using the designated tie down points (front and rear).

MAINTENANCE

Front Tie-Down Location

- ① Front tie-down points

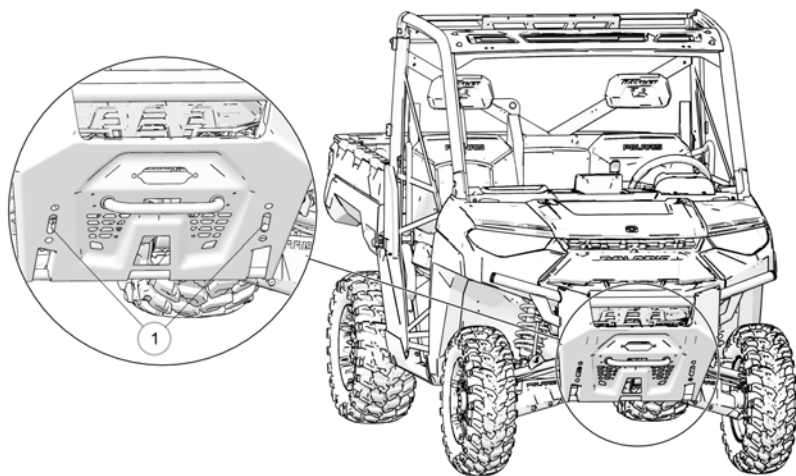

Rear Tie-Down Locations

- ② Rear tie-down points

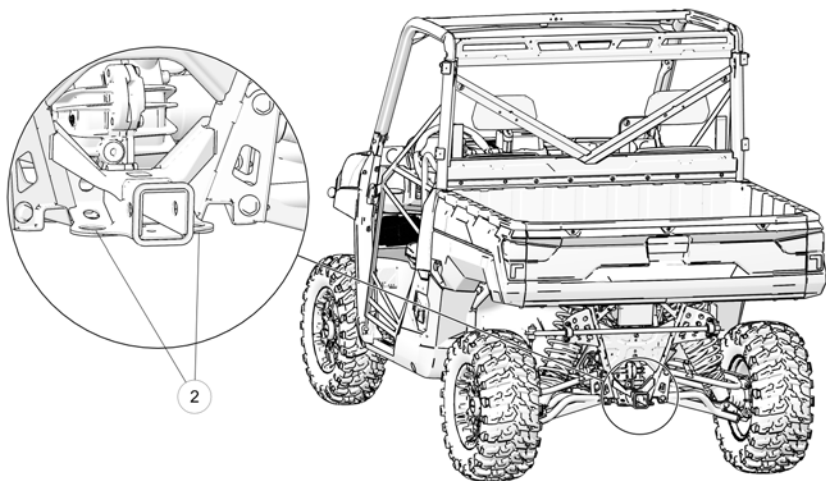

SPECIFICATIONS

RANGER XP KINETIC

DIMENSIONS	
Maximum Weight Capacity (includes weight of operator, passenger, cargo, accessories)	1500 lb (680 kg)
Curb Weight	Premium: 1751 lb (794 kg) Ultimate: 1976 lb (896 kg)
Test GVW - Rollover Protective Structure (ROPS)	3600 lb (1633 kg) per OSHA® 29 CFR 1928.53
Ground Clearance	14 in (36 cm)
Length	120 in (305 cm)
Width	62.5 in (158 cm)
Height	78 in (198 cm)
Wheelbase	81 in (206 cm)
Turning Radius	156 in (396 cm)

LOAD CAPACITY	
Cargo Box Dimensions (Inside)	36.75 x 54.25 x 12.5 in (93 x 138 x 32 cm)
Maximum Cargo Box Capacity	1250 lb (567 kg)
Maximum Cargo Box Capacity When Trailer Towing	600 lb (272 kg)
Payload Capacity	1500 lb (680 kg)
Hitch Towing Capacity	2500 lb (1134 kg)
Hitch Vertical Weight Capacity	250 lb (114 kg)
Hitch Type	Standard 2 in (5 cm) receiver
Seating	3

SPECIFICATIONS

LOAD CAPACITY	
Skid Plate	Plastic
Cargo System	Lock and Ride

PERFORMANCE	
Motor Configuration	AC Permanent Magnet (synchronous), 100V
Motor Performance	Peak Torque: 190 N·m Peak Power: 82 kW @ 5000 RPM 40 kW @ 5000 RPM (30 min. continuous power rating)
Controller	900A
Battery Pack	Traction Battery Premium: 100V 14.9 kWh Lithium-Ion Ultimate: 100V 29.8 kWh Lithium-Ion
DC-DC Power	900W (at peak)
Maximum Speed	High (H): 54 MPH (87 kph) Low (L): 26 MPH (42 kph)
Range (on flat ground))	Premium: Up to 45 mi. (72 km) Ultimate: Up to 80 mi. (129 km) (will vary with driving conditions)
Horsepower	110 HP
Torque	140 ft-lbs (16 N·m)
Accelerator	Redundant, non-contact, inductive-sensing pedal
On-board Charger	Premium: 3 kW Ultimate: 6 kW
Charge Time	See page 40 for details
Cooling	Active air and liquid

SPECIFICATIONS

DRIVELINE	
Primary	Gates synchronous belt drive H/L/N/P (electronic forward/reverse), shaft, 24mm wide, X9N 11mm HTD
Gearcase	2-speed non-synchronous with locking differential (Turf), Neutral, and Park
Drive System Type	High performance on-demand true AWD/2WD/VersaTrac Turf Mode

BRAKE SYSTEM	
Brakes	Foot Activated, 4 wheel hydraulic disc with dual-bore front calipers
Engine Braking System (EBS)	Regenerative braking

SUSPENSION	
Front suspension	Dual A-Arm 10 in (25 cm) Travel
Rear suspension	Dual A-Arm, IRS 10 in (25 cm) Travel
Tires - Front	29 x 9-14; PRO ARMOR X-TERRAIN
Tires - Rear	29 x 11-14; PRO ARMOR X-TERRAIN
Tire pressure	Front: 12 PSI (83 kPa) Rear: 14 PSI (97 kPa)
Tire Ply Rating	8 Ply Rated
Wheels	14 in (36 cm) Aluminum

FEATURES	
Instrumentation	Premium: Instrument Cluster Ultimate: Instrument Cluster + Digital Display
Auxiliary power	12V accessory outlets (one on dash, one in cargo box)
Drive Mode Switch	Sport, Standard, Eco+

SPECIFICATIONS

FEATURES	
Lights	Dual LED Headlamps, 1250 lm low beam, 2300 lm high beam, LED Front Accent Light with Charge Indicator, Dual LED Taillamps
Charging Kit	J1772, Combined Level 1 / Level 2 Mobile

POLARIS PRODUCTS

LUBRICANTS / SERVICE PRODUCTS

PRODUCT	SIZE (QUANTITY)	PART NUMBER
AGL	1 qt (12)	2878068
	1 gal (4)	2878069
Pump for Gallon Jug	3.8 l	2870465
Demand Drive	1 qt (12)	2877922
	2.5 gal (2)	2877923
Antifreeze / Coolant	1 qt (12)	2880514
	1 gal (6)	2880513
Grease Gun Kit, Premium All Season	—	2871312
All Season Grease	Four 3 oz packs (6)	2871322
	14 oz cartridge	2871423
U-Joint Grease	3 oz tube (24)	2871515
	14 oz cartridge	2871551
Dielectric Grease (Nyogel®)	—	2871329
DOT 4 Brake Fluid	—	2872189
Polaris Battery Tender Charger	—	2859044
Loctite® 565 Thread Sealant	—	2871956

TROUBLESHOOTING

VEHICLE WILL NOT OPERATE

POSSIBLE CAUSE	SOLUTION
High-voltage battery pack not charged	Charge the vehicle. See page 37 for details.
Key not properly engaged	Ensure the key is fully inserted into the key switch and turned to the ON position
Low 12V battery voltage	Recharge the battery pack. If problem persists, a replacement 12V battery may be necessary.
Loose 12V battery connections	Check all connections and tighten
Required torque exceeds motor capability	Apply the brakes and select low gear
High-voltage service disconnect removed	Verify high-voltage service disconnect installed correctly. See page 108 for details.
Vehicle in Charging Mode	Verify EVSE charger is disconnected
Invalid gear position	Shift vehicle to Park (P) and cycle Key Switch
PASS security system enabled	Input correct security code. See page 71 for details.
Broken drive belt	Contact your dealer for service.
Fault condition detected	<ul style="list-style-type: none"> • See page 130 if a fault code appears on the instrument cluster or display screen (if equipped). • Water may be present in the vehicle's internal electrical components. Allow some time for drying before attempting to start.

MOTOR STOPS OR LOSES PERFORMANCE

POSSIBLE CAUSE	SOLUTION
High-voltage battery pack not charged	Charge the vehicle. See page 37 for details.
Fault condition detected	<ul style="list-style-type: none"> • See page 130 if a fault code appears on the instrument cluster or display screen (if equipped). • Water may be present in the vehicle's internal electrical components. Allow some time for drying before attempting to start.
Extreme high ambient temperatures	Have the vehicle moved to an area with cooler ambient temperatures (such as indoors) or wait until ambient temperatures have decreased. See page 43 for details on vehicle operability in extreme temperatures.
Extreme low ambient temperatures	The vehicle may cease operating or experience decreased performance when cold ambient temperature is combined with low state of charge. See page 43 for details on vehicle operability in extreme temperatures.

VEHICLE NOT CHARGING

POSSIBLE CAUSE	SOLUTION
Power source malfunction	Verify the EVSE is connected to an active and appropriate power source. If powering from home, check the main breaker box for tripped fuses. See page 40 for details on appropriate power sources.
High-voltage service disconnect removed	Verify high-voltage service disconnect is installed correctly. See page 108 for details.

TROUBLESHOOTING

POSSIBLE CAUSE	SOLUTION
Fault condition detected	<ul style="list-style-type: none">• See page 130 if a fault code appears on the instrument cluster or display screen (if equipped).• Water may be present in the vehicle's internal electrical components. Allow some time for drying before attempting to charge.
Extreme high ambient temperatures	Have the vehicle moved to an area with cooler ambient temperatures (such as indoors) or wait until ambient temperatures have decreased before charging. See page 42 for details on vehicle charging in extreme temperatures.
Extreme low ambient temperatures	<ul style="list-style-type: none">• Allow the high-voltage battery pack heaters several minutes to warm up and charging will resume.• If the high-voltage battery pack heaters do not activate, the vehicle may be at too low state of charge. Move the vehicle to a warmer area (such as indoors) and connect to a charger. <p>See page 42 for details on vehicle charging in extreme temperatures.</p>

TROUBLESHOOTING

DIAGNOSTIC TROUBLE CODES

FAULT CODE	SPN	FMI	DESCRIPTION
B102A	520669	6	Headlight Relay / Rear Running Lights Output Short Circuit to Ground
C0256	516247	3	Winch Out Driver Circuit Voltage High
C0257	516247	1	Winch Out Driver Open Circuit
C0258	516247	4	Winch Out Driver Short to Ground
C0259	516249	16	Plowing in High Range
C025A	516248	3	Autostop Winch Out Signal Fault
C025B	516248	4	Autostop Winch In Signal Fault
C025C	168	1	Battery too Low for Plow Mode Operation
C025D	516246	3	Winch In Driver Circuit Voltage High
C025E	516246	1	Winch In Driver Open Circuit
C025F	516246	4	Winch In Driver Short to Ground
C1051	520222	6	EPS Current Above Normal
C1052	520223	31	EPS Torque Sensor Partial Failure
C1053	520224	31	EPS Torque Sensor Full Failure
C1054	520225	16	EPS Inverter Temperature Above Normal
C1055	520225	0	EPS Inverter Temperature Critical
C1063	168	3	EPS Detected System Voltage High
C1064	168	4	EPS Detected System Voltage Low
C1069	84	19	EPS Detected Vehicle Speed Data Error
C106A	520228	12	EPS Encoder Communications Error
C106B	520228	31	EPS Encoder Variance Error
C106F	520229	31	EPS Boot Count Error
C1070	520229	12	EPS Steering Software Error
C1073	628	12	EPS EEPROM Failure
C1074	630	13	EPS Internal Checksum Error
C108E	516126	18	12V Voltage Input Low

TROUBLESHOOTING

FAULT CODE	SPN	FMI	DESCRIPTION
C109B	520229	13	EPS Software Error - MFX Calibration
C10BF	516868	31	4x4 Switch Input Fault
C10C6	516870	4	Front Accent Light Output Short Circuit to Ground
C10C7	516870	6	Front Accent Light Output Overload
C10C8	516969	6	Chassis Relay Output Short Circuit to Ground
C10CA	516977	6	Instrumentation Output Short Circuit to Ground
C10CE	516975	6	DC/DC Relay Output Short Circuit to Ground
C10D0	516987	6	Driveline VCM Output Short Circuit to Ground
C10D2	520500	31	12V Input Polarity Reversed
C10D3	520500	18	12V Voltage Input Low
C10D4	520500	1	12V Voltage Input Critically Low
C10EE	516987	31	International VCM Output Short Circuit to Ground
C1126	520504	4	Cooling Fan Relay Output Short Circuit to Ground
C11DB	520448	12	EPS Bridge Fault
C11E3	520448	14	MOSFET Bridge Error 3
C11E5	520192	31	Corrupt Configuration Parameters No Sub Type Information
C11E6	520448	31	MOSFET Bridge Error
C11E7	520228	13	Motor encoder error bits set Internal Electronic Failure
C1601	628	13	EPS Checksum Error
C2300	516199	31	Configurable Address Claim Conflict Fault
C230D	516201	31	VCM Failure to Set CAN Address
C2326	520504	6	Cooling Fan Relay Output Overload
P0071	171	2	Ambient Air Temperature Signal Incorrect

TROUBLESHOOTING

FAULT CODE	SPN	FMI	DESCRIPTION
P0914	523	2	Gear Sensor Signal Circuit Fault
P0916	523	4	Gear Sensor Signal Low
P0917	523	3	Gear Sensor Signal High
P0ABA	523920	11	Traction Battery Current Sensor Fault
P1007	1800	16	Traction Battery High Temp Shutdown
P1008	517535	6	Dash Switch Backlight Shorted to Ground
P1026	520207	6	AWD Output Overload
P1027	746	6	Turf Solenoid Output Overload
P1029	8096	31	Traction Battery Isolation Fault
P102A	9059	16	Traction Motor High Temp Warning
P102B	9059	0	Traction Motor High Temp Shutdown
P102C	10216	0	Motor Controller High Temp Warning
P102D	10216	16	Motor Controller High Temp Shutdown
P102E	8098	5	HVIL Open Circuit
P102F	1800	15	Traction Battery High Temp Warning
P1031	1800	18	Traction Battery Low Temp Warning
P1032	4990	31	Battery Charger Not Detected
P1033	4990	12	Battery Charger Error
P1034	7895	18	Battery Low SOC
P1035	8414	31	Traction Battery Awaiting Connection
P1036	8414	12	Traction Battery Disabled
P1037	8414	14	Traction Battery Fail to Connect
P1038	8091	31	Traction Battery Contactor Open
P1039	8091	12	Traction Battery Contactor Fault
P103A	5922	0	Traction Battery Cell high-voltage - Charge Disabled

TROUBLESHOOTING

FAULT CODE	SPN	FMI	DESCRIPTION
P103B	5923	1	Traction Battery Cell Low Voltage - Charge Disabled
P103C	8101	31	Cell Balance Status Timeout
P103D	5919	18	Traction Battery 0% SOC
P103E	5919	1	Traction Battery Voltage Critically Low
P103F	91	15	Throttle Applied when Ineligible
P1040	91	16	Throttle Applied when Ineligible
P1041	91	2	Accelerator Position Inconsistent Or Incorrect
P1042	516967	31	Motor Controller Stopping Fault
P1045	520517	6	Motor Controller Enable Output Short Circuit to Ground
P1047	516982	6	Power Distribution Overcurrent
P1048	516829	1	Traction Battery Fault - Charge Disabled
P1049	516829	12	Charging Fault
P104A	516461	12	Vehicle Battery Discharge Fault
P104B	12931	2	Charge Port Pilot Signal Invalid
P104C	8094	31	Traction Battery Pre-Charge Failure
P104D	1800	2	Traction Battery Temperature Sensor Fault
P104E	523920	31	Traction Battery Internal Logic Fault
P104F	8414	11	Traction Battery State Fault
P1050	8414	2	Traction Battery Minor Logic Fault

WARRANTY

LIMITED WARRANTY

Polaris Industries Inc., 2100 Highway 55, Medina, MN 55340 (Polaris) gives a ONE YEAR LIMITED WARRANTY on all components of your vehicle against defects in material or workmanship. Laws and regulations in your jurisdiction may give extra protection. This ONE YEAR LIMITED WARRANTY covers parts and labor charges for repair or replacement of defective parts and begins on the date of purchase by the original retail purchaser. This warranty is transferable to another owner during the warranty period through an authorized dealer, but any such transfer will not extend the original term of the warranty. The duration of this warranty may vary by international region based upon local laws and regulations.

REGISTRATION

At the time of sale, the Warranty Registration Form must be completed by your dealer and submitted to POLARIS within ten days of purchase. Upon receipt of this registration, POLARIS will record the registration for warranty. No verification of registration will be sent to the purchaser as the copy of the Warranty Registration Form will be your proof of warranty coverage. If you have not signed the original registration and received the customer copy, please contact your dealer immediately. **NO WARRANTY COVERAGE WILL BE ALLOWED UNLESS YOUR VEHICLE IS REGISTERED WITH POLARIS.** Initial dealer preparation and set-up of your vehicle is very important in ensuring trouble-free operation. Purchasing a machine in the crate or without proper dealer set-up will void your warranty coverage.

WARRANTY COVERAGE AND EXCLUSIONS

LIMITATIONS OF WARRANTIES AND REMEDIES

This Polaris limited warranty excludes any failures that are not caused by a defect in material or workmanship. THIS WARRANTY DOES NOT COVER CLAIMS OF DEFECTIVE DESIGN. This warranty also does not cover acts of God, accidental damage, normal wear and tear, abuse or improper handling. This warranty also does not cover any vehicle, component, or part that has been altered structurally or electrically, modified, neglected, improperly maintained or used for racing, competition or purposes other than for which it was designed.

This warranty excludes damages or failures resulting from improper lubrication; surface imperfections caused by external stress, heat, cold or contamination; operator error or abuse; improper component alignment, tension, adjustment; snow, water, dirt or other foreign substance ingestion/contamination; improper maintenance; modified components; use of aftermarket or unapproved components, accessories, or attachments; use of unapproved software or calibration; unauthorized repairs; or repairs made after the warranty period expires or by an unauthorized repair center.

This warranty excludes the expected reduction in range or capacity that the high-voltage battery pack may experience as a result of time and usage. However, a high-voltage battery pack that exhibits a capacity reduction in excess of 20% of the published nominal capacity is covered under the limited warranty. The reduction would need to be verified by an authorized dealer by checking the battery management system (BMS) log data.

This warranty excludes non-recoverable high-voltage battery packs. It is the owner's responsibility to ensure the state of charge (SoC) of the high-voltage battery is maintained properly and never fully depleted. If the high-voltage battery charge becomes fully depleted, the high-voltage battery can cease operating permanently (also known as non-recoverable).

This warranty excludes damages or failures caused by abuse, accident, fire, or any other cause other than a defect in materials or workmanship and provides no coverage for consumable components, general wear items, or any parts exposed to friction surfaces, stresses, environmental conditions and/or contamination for which they were not designed or not intended, including but not limited to the following items:

- Wheels and tires
- Suspension components
- Brake components
- Seat components
- Steering components
- 12-Volt Battery
- Light bulbs/Sealed beam lamps
- Lubricants
- Finished and unfinished surfaces
- Bushings
- Hydraulic components and fluids
- Circuit breakers/Fuses
- Electronic components
- Sealants
- Coolants
- Bearings

LUBRICANTS AND FLUIDS

Damage or failure resulting from the use of non-recommended lubricants or fluids is not covered by this warranty.

This warranty provides no coverage for personal loss or expense, including mileage, transportation costs, hotels, meals, shipping or handling fees, product pick-up or delivery, replacement rentals, loss of product use, loss of profits, or loss of vacation or personal time.

THE EXCLUSIVE REMEDY FOR BREACH OF THIS WARRANTY SHALL BE, AT Polaris' OPTION, REPAIR OR REPLACEMENT OF ANY DEFECTIVE MATERIALS, COMPONENTS, OR PRODUCTS. THE REMEDIES SET FORTH IN THIS WARRANTY ARE THE ONLY REMEDIES AVAILABLE TO ANY PERSON FOR BREACH OF THIS WARRANTY. Polaris SHALL HAVE NO LIABILITY TO ANY PERSON FOR INCIDENTAL, CONSEQUENTIAL OR SPECIAL DAMAGES OF ANY DESCRIPTION, WHETHER ARISING OUT OF EXPRESS OR IMPLIED WARRANTY OR ANY OTHER CONTRACT, NEGLIGENCE, OR OTHER TORT OR OTHERWISE. THIS EXCLUSION OF CONSEQUENTIAL, INCIDENTAL, AND SPECIAL DAMAGES IS INDEPENDENT FROM AND SHALL SURVIVE ANY FINDING THAT THE EXCLUSIVE REMEDY FAILED OF ITS ESSENTIAL PURPOSE.

THE IMPLIED WARRANTY OF FITNESS FOR A PARTICULAR PURPOSE IS EXCLUDED FROM THIS LIMITED WARRANTY. ALL OTHER IMPLIED WARRANTIES (INCLUDING BUT NOT LIMITED TO THE IMPLIED WARRANTY OF MERCHANTABILITY) ARE LIMITED IN DURATION TO THE ABOVE SIX MONTH WARRANTY PERIOD. Polaris DISCLAIMS ALL EXPRESS WARRANTIES NOT STATED IN THIS WARRANTY. SOME STATES DO NOT PERMIT THE EXCLUSION OR LIMITATION OF INCIDENTAL OR CONSEQUENTIAL DAMAGES OR ALLOW LIMITATIONS ON THE DURATION OF IMPLIED WARRANTIES, SO THE ABOVE LIMITATIONS MAY NOT APPLY TO YOU IF INCONSISTENT WITH CONTROLLING STATE LAW.

WARRANTY

HOW TO OBTAIN WARRANTY SERVICE

If your vehicle requires warranty service, you must take it to a POLARIS Servicing Dealer. When requesting warranty service you must present your copy of the Warranty Registration Form to the dealer. (THE COST OF TRANSPORTATION TO AND FROM THE DEALER IS YOUR RESPONSIBILITY.) POLARIS suggests that you use your original selling dealer; however, you may use any POLARIS Servicing Dealer to perform warranty service.

IN THE COUNTRY WHERE YOUR PRODUCT WAS PURCHASED:

Warranty or Service Bulletin repairs must be done by an authorized POLARIS dealer, or other qualified person. If you move or are traveling within the country where your product was purchased, Warranty and Service Bulletin repairs may be requested from any authorized POLARIS dealer, or other qualified person, that sells the same line as your product.

OUTSIDE THE COUNTRY WHERE YOUR PRODUCT WAS PURCHASED:

If you are traveling temporarily outside the country where your product was purchased, you should take your product to an authorized POLARIS dealer, or other qualified person. You must show the dealer photo identification from the country of the selling dealer's authorized location as proof of residence. Upon residence verification, the servicing dealer will be authorized to perform the warranty repair.

IF YOU MOVE:

If you move to another country, be sure to contact POLARIS Customer Assistance and the customs department of the destination country before you move. Product importation rules vary considerably from country to country. You may be required to present documentation of your move to POLARIS in order to continue your warranty coverage. You may also be required to obtain documentation from POLARIS in order to register your product in your new country. You should warranty register your product at a local POLARIS dealer in your new country immediately after you move to continue your warranty coverage and to ensure that you receive information and notices regarding your product.

IF YOU PURCHASE FROM A PRIVATE PARTY:

If you purchase a POLARIS product from a private party, to be kept and used outside of the country in which the product was originally purchased, all warranty coverage will be denied. You must nonetheless register your product under your name and address with a local POLARIS dealer in your country to ensure that you receive safety information and notices regarding your product.

EXPORTED PRODUCTS

EXCEPT WHERE SPECIFICALLY REQUIRED BY LAW, THERE IS NO WARRANTY OR SERVICE BULLETIN COVERAGE ON THIS PRODUCT IF IT IS SOLD OUTSIDE THE COUNTRY OF THE SELLING DEALER'S AUTHORIZED LOCATION. This policy does not apply to products that have received authorization for export from POLARIS. Dealers may not give authorization for export. You should consult an authorized dealer to determine this product's warranty or service coverage if you have any questions. This policy does not apply to products registered to government officials or military personnel on assignment outside the country of the selling dealer's authorized location. This policy does not apply to Safety Bulletins.

NOTICE

If your product is registered outside of the country where it was purchased and you have not followed the procedure set above, your product will no longer be eligible for warranty or service bulletin coverage of any kind, other than safety recalls. Products registered to government officials or military personnel on assignment outside of the country where the product was purchased will continue to be covered by the Limited Warranty.

Please work with your dealer to resolve any warranty issues. Dealership contacts can be found via this website, if needed:

www.polaris.com/en-us/contact

Should your dealer require any additional assistance, they will contact the appropriate person at POLARIS.

This warranty gives you specific legal rights, and you may also have other rights which vary from state to state or in different countries. If any of the above terms are void because of federal, state, local law, all other warranty terms will remain in effect.

For questions call POLARIS Owner Connections:

United States & Canada: 1-800-POLARIS (1-800-765-2747)

French: 1-800-268-6334

To report a safety defect to Transport Canada, you may either fill out an online defect complaint form at their website:

English: <http://www.tc.gc.ca/recalls>

French: <http://www.tc.gc.ca/rappels>

Or contact their Defect Investigations and Recalls Division by calling toll-free 1-800-333-0510 (Canada) or 819-994-3328 (Ottawa-Gatineau area / International).

MAINTENANCE LOG

MAINTENANCE LOG

Use the following chart to record periodic maintenance.

DATE	MILES (KM)	TECHNICIAN	SERVICE PERFORMED / COMMENTS

12V Battery Installation 110

A

Accelerator Pedal 57
Accent Light Switch 54
AUX Switch 55
Auxiliary Outlet 52
AWD Switch 55
Axle and Wheel Nut Torque
Specifications 106

B

Backlight Brightness 69
Backlight Color 68
Battery Maintenance and
Charging (12V) 109
Battery Pack Heaters 42
Battery Removal 109
Before You Ride 75
Brake Lights 114
Brake Pedal 57
Brakes 103
Braking 89

C

Cab Nets 60
Charging Components 38
Charging in Extreme Ambient
Temperatures 42
Charging Your Vehicle 37
Clean the Exterior 118
Clock 69
Component Location Diagram /
Power Wash Warning 32
Component Locations 50
Console 51

D

Demand Change Oil Change 101
Demand Drive Oil Check 101

Device Compliance Statements 77
Diagnostic Trouble Codes 73, 130
Direction Selector Switch 54
Disconnecting Service to 12V
Battery 108
Display Mode 86
Display Units (Standard/Metric) 70
Drive Mode Switch 53
Driver Information Warning 30

E

Electric Vehicle Safety 23
Electric Vehicles and Water 42
Elevating the Vehicle for Service ... 93
Estimated Remaining Range 46
EV Info 68
EVSE Charge Port Warning 31
Exported Products 139

F

Factors that Influence Driving
Range 45
FCC Compliance Statement 76
Fluid Levels 118
Fluid Part Numbers 125
Fuses 111

G

Gauge Settings Menu 67
Gear Selector 56
Gearcase Specification Chart 98
Good Charging Habits 36

H

Headlight Beam Adjustment 113
Headlight Switch 53
High-Voltage Battery Pack
Degradation 46
How To Obtain Warranty
Service 138

I	
Icon Bar	84
Ideal Conditions for Storage	47
Indicator Lamps	62
Instrument Cluster	61

K	
Key Switch	53

L	
Lights	113
Limitations Of Warranties And Remedies	136
Limited Warranty	135
Load / Passenger / Tire Pressure Warning	34
Low-Charge Operation	91
Lubricants / Service Products	125
Lubrication Recommendations	97

M	
Maintenance Log	141
Maintenance Overview	93
Maximum Payload Warning	32
Mode and Toggle Buttons	61
Mode Information Displays	66
Motor Power Level	61
Motor Stops or Loses Performance	128

N	
Near-field Communication (NFC)	49
Notice	139

P	
Part Numbers	125

Performance Limitation (if equipped)	69
PIN Activated Security System (P.A.S.S.) (if equipped) Instrument Cluster	71
Pin Activated Security System (P.A.S.S.) (if equipped) — Ride Command	82
Polaris Products	125
Polishing the Vehicle	116
Power Sources	40
Powering the Vehicle	89
Programmable Service Interval	71

R	
Radiator Coolant Level	102
Regenerative Braking	46
Regenerative Braking Level	61
Registration, Warranty	135
Removal from Storage	118
Ride Command Buttons	80
Driveline Mode	83
Gauge Screens	85
Overview	80
Settings	85
Ride Command User's Guide	75
RIDE COMMAND+	88
Rider Information Center	65
Rodents / Pests	118
Rollover Protective Structure (ROPS)	59

S	
Safe Operating Guidelines Stopping the Motor and Parking the Vehicle	90
Safety Driver and Passenger Qualifications	12
Driving Guidelines	17
Owner Requirements	11
Preprepare Yourself, Passengers, and Cargo for the Ride	15

Prepare Vehicle for the Ride	13
Safety Labels and Locations	29
Fuel Transport Warning.....	33
Safety Symbols	4
Seat and Storage	
Compartments	59
Seat Belt.....	58
Service Disconnect Warning	31
Severe Use Definition	94
Signal Words	4
Specifications	121
Steering Wheel	56
Steering Wheel Inspection	104
Storage Area / Covers	118
Storing the Vehicle	117
Suspension Adjustment	105

T

Tire Tread Depth	106
Tires	106
Tools for Safe Riding	7
Trailer Hitch Bracket	60
Trailer Weight Maximums	33
Transmission Oil Change	100
Transmission Oil Check	99
Transporting the Vehicle.....	119
Trip Meter	70
Trip Time	70

U

Update Maps	87
Update Software	86
USB Dongle Location	86
USB Port	52

V

Vehicle Break-in	
Brake System Break-in	89
Vehicle Charge Status	39
Vehicle Identification Numbers	9
Vehicle Not Charging.....	128

Vehicle Performance in	
Extreme Ambient	
Temperatures	43
Vehicle Range	45
Vehicle Will Not Operate	127
Vehicle-to-Vehicle	
Communication (V2V).....	76

W

Warning Symbols	4
Washing the Vehicle.....	115
Washing Tips.....	115
Welcome Page	3
Wheel Installation	107
Wheel Removal.....	106



For your nearest Polaris dealer,
call 1-800-POLARIS (765-2747)
or visit www.polaris.com

Polaris Inc.
2100 Highway 55
Medina, MN 55340



Part No. 9941433 Rev 01
Printed in USA