

**2021**



For Maintenance and Safety

# **OWNER'S MANUAL**

**RZR Trail 900  
RZR Trail S 900**

**POLARIS**  
Think Outside



## WARNING

Read, understand, and follow all of the instructions and safety precautions in this manual and on all product labels.

Failure to follow the safety precautions could result in serious injury or death.



## WARNING

Operating, servicing, and maintaining a passenger vehicle or off-road vehicle can expose you to chemicals including engine exhaust, carbon monoxide, phthalates, and lead, which are known to the State of California to cause cancer and birth defects or other reproductive harm. To minimize exposure, avoid breathing exhaust, do not idle the engine except as necessary, service your vehicle in a well-ventilated area and wear gloves or wash your hands frequently when servicing your vehicle.

For more information go to [www.P65Warnings.ca.gov/passenger-vehicle](http://www.P65Warnings.ca.gov/passenger-vehicle).



*For videos and more information  
about a safe riding experience with  
your Polaris vehicle, scan this QR Code®  
with your smartphone.*

**POLARIS**

**RZR**

2021 RZR Owner's Manual

**Trail 900**  
**Trail S 900**

Unless noted, trademarks are the property of Polaris Industries Inc.

Sachs® is a registered trademark of ZF Sachs AG Corporation. Recreational Off-Highway Vehicle Association® and ROHVA® are registered trademarks of the Recreational Off-Highway Vehicle Association. Tread Lightly® is a registered trademark of the United States Department of Agriculture. BatteryMINDer® is a registered trademark of VDC Electronics Inc. Loctite® is a registered trademark of Henkel Corporation. NYOGEL® is a registered trademark of Nye Lubricants, Inc. WD-40® is registered to WD-40 Manufacturing Company. QR Code® is a registered trademark of DENSO WAVE INCORPORATED. NGK® is a registered trademark of NGK Spark Plug Co., Ltd. OSHA® is a registered trademark of the Occupational Safety and Health Administration, U. S. Dept. of Labor. FOX® is a registered trademark of Fox Factory Inc.

Copyright 2020 Polaris Industries Inc. All information contained within this publication is based on the latest product information at the time of publication. Due to constant improvements in the design and quality of production components, some minor discrepancies may result between the actual vehicle and the information presented in this publication. Depictions and/or procedures in this publication are intended for reference use only. No liability can be accepted for omissions or inaccuracies. Any reprinting or reuse of the depictions and/or procedures contained within, whether whole or in part, is expressly prohibited.

The original instructions for this vehicle are in English. Other languages are provided as translations of the original instructions.

Printed in U.S.A.

9931539 R01



Thank you for purchasing a POLARIS vehicle, and welcome to our world-wide family of POLARIS enthusiasts. Be sure to visit us online at [www.polaris.com](http://www.polaris.com) for the latest news, new product introductions, upcoming events, career opportunities and more.

Here at POLARIS we proudly produce an exciting line of utility and recreational products. We believe POLARIS sets a standard of excellence for all utility and recreational vehicles manufactured in the world today. Many years of experience have gone into the engineering, design, and development of your POLARIS vehicle, making it the finest machine we've ever produced.

For safe and enjoyable operation of your vehicle, be sure to follow the instructions and recommendations in this owner's manual. Your manual contains instructions for minor maintenance, but information about major repairs is outlined in the POLARIS Service Manual and can be performed by a factory certified Master Service Dealer (MSD) technician.

Your POLARIS dealer knows your vehicle best and is interested in your total satisfaction. Your POLARIS dealership can perform all of your service needs during and after the warranty period.

For the most up-to-date owner's manual visit <https://www.polaris.com/en-us/owners-manuals>.

## SAFETY SYMBOLS AND SIGNAL WORDS

---

The following signal words and symbols appear throughout this manual and on your vehicle. Your safety is involved when these words and symbols are used. Become familiar with their meanings before reading the manual.

### DANGER

DANGER indicates a hazardous situation which, if not avoided, WILL result in death or serious injury.

### WARNING

WARNING indicates a hazardous situation which, if not avoided, COULD result in death or serious injury.

### CAUTION

CAUTION indicates a hazardous situation which, if not avoided, COULD result in minor to moderate injury.

### NOTICE

NOTICE provides key information by clarifying instructions.

### IMPORTANT

IMPORTANT provides key reminders during disassembly, assembly, and inspection of components.

The Prohibition Safety Sign indicates an action NOT to take in order to avoid a hazard.



The Mandatory Action Sign indicates an action that NEEDS to be taken to avoid a hazard.



## TABLE OF CONTENTS

---

<b>Introduction</b> . . . . .	<b>7</b>
<b>Safety</b> . . . . .	<b>9</b>
<b>Features and Controls</b> . . . . .	<b>29</b>
<b>Operation</b> . . . . .	<b>81</b>
<b>Winch Guide</b> . . . . .	<b>101</b>
<b>Emission Control Systems</b> . . . . .	<b>111</b>
<b>Maintenance</b> . . . . .	<b>113</b>
<b>Specifications</b> . . . . .	<b>189</b>
<b>Polaris Products</b> . . . . .	<b>195</b>
<b>Troubleshooting</b> . . . . .	<b>197</b>
<b>Warranty</b> . . . . .	<b>205</b>
<b>Maintenance Log</b> . . . . .	<b>215</b>



# INTRODUCTION

## BEFORE YOU RIDE

 **WARNING**

Failure to heed the warnings and safety precautions contained in this manual can result in severe injury or death. Your POLARIS vehicle is not a toy and can be hazardous to operate. This vehicle handles differently than cars, trucks or other off-road vehicles. A collision or rollover can occur quickly, even during routine maneuvers like turning, or driving on hills or over obstacles, if you fail to take proper precautions.

- Read this owner's manual and review the safety DVD that came with your vehicle. A free extra copy of the DVD can be obtained by contacting your local POLARIS dealer. Understand all safety warnings, precautions and operating procedures before operating the vehicle. Keep this manual with the vehicle.
- This vehicle is an **ADULT VEHICLE ONLY**. You **MUST** be at least age 16 and have a valid driver's license to operate this vehicle.
- All riders must be able to sit with backs against the seat, both feet flat on the floor and both hands on the steering wheel (if driving) or on a passenger hand hold.
- Always use the cab nets (or doors) while riding in this vehicle. Always keep hands, feet and all other body parts inside the vehicle at all times.
- Always wear a seat belt when riding in this vehicle. Always wear a helmet, eye protection, gloves, long-sleeve shirt, long pants and over-the-ankle boots.
- Never operate this vehicle under the influence of drugs or alcohol, as these conditions impair judgement and the operator's ability to react.
- Complete the steps described in the New Operator Driving Procedures section. Never allow a guest to operate this vehicle until the guest has completed the New Operator Driving Procedures.

## INTRODUCTION

---

### EUROPEAN VIBRATION AND NOISE

The driver-perceived noise and hand/arm and whole body vibration levels of this machinery is measured per EN 15997.

The operating conditions of the machinery during testing:

The vehicles were in like-new condition. The environment was controlled as indicated by the test procedure(s).

The uncertainty of vibration exposure measurement is dependent on many factors, including:

- Instrument and calibration uncertainty
- Variations in the machine such as wear of components
- Variation of machine operators such as experience or physique
- Ability of the worker to reproduce typical work during measurements
- Environmental factors such as ambient noise or temperature

### VEHICLE IDENTIFICATION NUMBERS

Record your vehicle's identification number ①, engine serial number ②, and key number ③ in the spaces provided. Remove the spare key and store it in a safe place. An ignition key can be duplicated only by ordering a POLARIS key blank (using your key number) and mating it with one of your existing keys. The ignition switch must be replaced if all keys are lost.

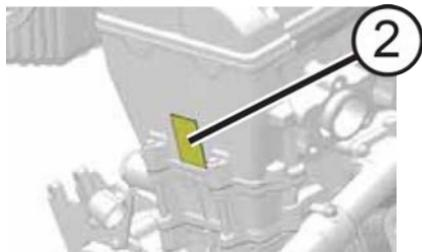
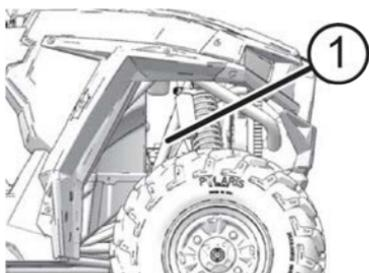
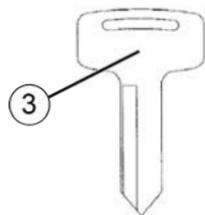

Vehicle Model Number:	
Vehicle Identification Number:	
Engine Serial Number:	
Key Number:	

## SAFETY

### SAFETY TRAINING

Safety training is a top priority for POLARIS. POLARIS strongly encourages you and any family members who will be riding this vehicle to take a training course

ROHVA® (Recreational Off-Highway Vehicle Association®) provides both an online safety e-course and a hands-on safety course. To access this valuable training, visit [www.rohva.org](http://www.rohva.org).

Your POLARIS vehicle is considered an off-road vehicle. Familiarize yourself with all laws and regulations concerning the operation of this vehicle in your area.

We strongly advise you to strictly follow the recommended maintenance program outlined in your owner's manual. This preventive maintenance program is designed to ensure that all critical components on your vehicle are thoroughly inspected at specific intervals.

**For more information about recreational off-road vehicle safety in the United States, visit [www.rohva.org](http://www.rohva.org) or call POLARIS at 1-800-342-3764.**

## SAFETY

---

### SAFE RIDING GEAR

Always wear a helmet, eye protection, gloves, long-sleeve shirt, long pants, over-the-ankle boots and seat belt (if equipped) at all times. Protective gear reduces the chance of injury.

### RIDER COMFORT

Under certain operating conditions, heat generated by the engine and exhaust system can elevate temperatures in the rider cab area. The condition occurs most frequently when a vehicle is being operated in high ambient temperatures at low speeds and/or high load conditions for an extended period of time. The use of certain windshield, roof and/or cab systems may contribute to this condition by restricting airflow.

Any discomfort due to heat buildup in this area can be minimized by wearing proper riding apparel and by varying speeds to increase airflow.

- ① Helmet
- ② Eye Protection
- ③ Long Sleeves
- ④ Gloves
- ⑤ Long Pants
- ⑥ Over-the-Ankle Boots



## HELMET

Wearing a helmet can prevent a severe head injury. Whenever riding this POLARIS vehicle, always wear a helmet that meets or exceeds established safety standards. Clasp the buckle and pull each strap tight to ensure the helmet is properly secured to the head.

Parents and supervising adults should verify that young operators have a helmet that fits, and should obtain one of proper size if it does not fit before allowing operation.

Approved helmets in the USA and Canada bear a U.S. Department of Transportation (DOT) label.



Approved helmets in Europe, Asia and Oceania bear the ECE 22.05 label. The ECE mark consists of a circle surrounding the letter E, followed by the distinguishing number of the country which has granted approval. The approval number and serial number will also be displayed on the label.

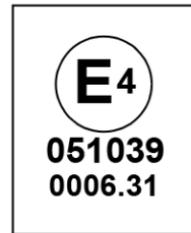

## EYE PROTECTION

Do not depend on eyeglasses or sunglasses for eye protection. Whenever riding this POLARIS vehicle, always wear shatterproof goggles or use a shatterproof helmet face shield. POLARIS recommends wearing approved Personal Protective Equipment (PPE) bearing markings such as VESC 8, V-8, Z87.1, or CE. Make sure protective eye wear is kept clean.

## GLOVES

Wear gloves for comfort and for protection from sun, cold weather and other elements.

## BOOTS

Wear sturdy over-the-ankle boots for support and protection. Never ride a POLARIS vehicle with bare feet or sandals.

## CLOTHING

Wear long sleeves and long pants to protect arms and legs.

## SAFETY

### SAFETY LABELS AND LOCATIONS

Warning labels have been placed on the vehicle for your protection. Read and follow the instructions of the labels on the vehicle carefully. If any of the labels depicted in this manual differ from the labels on your vehicle, always read and follow the instructions of the labels on the vehicle.

If an informational or graphic label becomes illegible or comes off, contact your POLARIS dealer or qualified person to purchase a replacement. Replacement safety labels are provided by POLARIS at no charge. The part number is printed on the label.

- ① Proper Use Warning
- ② Seat Belt Warning
- ③ Payload Warning
- ④ Riders Warning
- ⑤ Drive Responsibly Warning

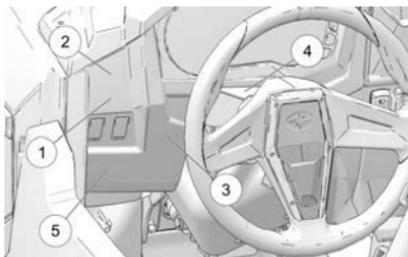

### PROPER USE WARNING

#### WARNING

Require Proper Use of Your Vehicle

Do your part to prevent injuries:

- Do not allow careless or reckless driving.
- Make sure operators are 16 or older with a valid driver's license.
- Do not let people drive or ride after using alcohol or drugs.
- Do not allow operation on public roads (unless designated for off-highway vehicle access) - collisions with cars and trucks can occur.
- **RZR:** Do not exceed seating capacity: 1 passenger.
- **RZR 4:** Do not exceed seating capacity: 3 passengers.

### RIDERS WARNING

#### Be Sure Riders Pay Attention and Plan Ahead

If you think or feel the vehicle may tip or roll, reduce your risk of injury:

- Keep a firm grip on the steering wheel or hand holds and brace yourself.
- Do not put any part of your body outside of the vehicle for any reason.

## PAYLOAD WARNING

### WARNING

MODEL	Never Exceed	If Total Payload Exceeds
RZR	43 MPH (69 kph)	430 lbs. (195 kg)
RZR S	62 MPH (100 kph)	430 lbs. (195 kg)
RZR XC	55 MPH (88 kph)	430 lbs. (195 kg)
RZR 4	68 MPH (110 kph)	860 lbs. (390 kg)

## SEAT BELT WARNING

Improper vehicle use can result in SEVERE INJURY or DEATH.

### Be Prepared

- Fasten seat belts.
- Wear an approved helmet and protective gear.
- ALWAYS use cab nets and/or doors.
- Each rider must be able to sit with back against seat, feet flat on the floor, and hands on steering wheel or hand holds. Stay completely inside the vehicle.



LOCATE AND READ OWNER'S MANUAL. FOLLOW ALL INSTRUCTIONS AND WARNINGS. ALWAYS REVIEW SAFETY VIDEO AND TAKE ROHVA® TRAINING ([rohva.org](http://rohva.org)).

## FUEL TRANSPORT WARNING

NEVER carry fuel or other flammable liquids on this vehicle.  
Failure to follow this instruction could lead to serious burn injuries or death.



# SAFETY

## DRIVE RESPONSIBLY WARNING

### WARNING:

#### Drive Responsibly

Rollovers have caused severe injuries and death, even on flat, open areas.

#### Avoid loss of control and rollovers:

- Avoid abrupt maneuvers, sideways sliding, skidding or fishtailing, and never do donuts.
- Slow down before entering a turn.
- Avoid hard acceleration when turning, even from a stop.
- Plan for hills, rough terrain, ruts and other changes in traction and terrain.
- Avoid paved surfaces.
- Avoid sidehilling (riding across slopes).



## BELT DEBRIS WARNING

### ① Belt Debris Warning

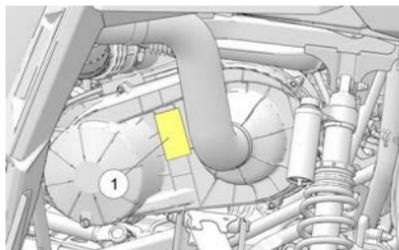

### WARNING

Improper service or maintenance of this PVT system can result in vehicle damage, SEVERE INJURY or DEATH.

Always look for and remove debris inside and around the clutch and vent system when replacing the belt.

Read owner's manual or see your POLARIS dealer or authorized equivalent person.

## AIR BOX AND INTAKE DUCT CAUTIONS

### ⚠ CAUTION

Use a Polaris approved air filter ①. The use of a non-Polaris approved air filter may cause engine damage. Before installing filter, ensure there is no dirt or debris in the clean side of the intake tube. The air filter must be properly seated before the lid is reinstalled. Please reference your owner's manual for additional information regarding air filter service.

### ⚠ CAUTION

Air intake tube ② must be fully seated on air box and throttle body. Inspect full perimeter if serviced. Clamps at air box and throttle body must be torqued to 49 in-lbs (5.5 N·m) or severe engine damage may occur.

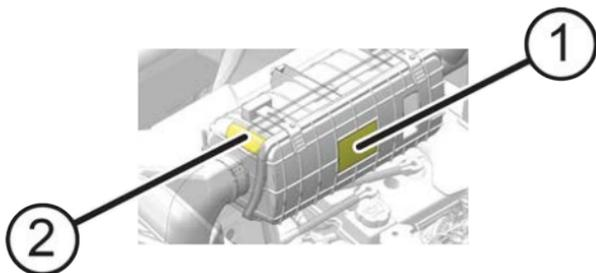

# SAFETY

## LOAD / PASSENGER / TIRE PRESSURE WARNING

① Load / Passenger / Tire Pressure Warning

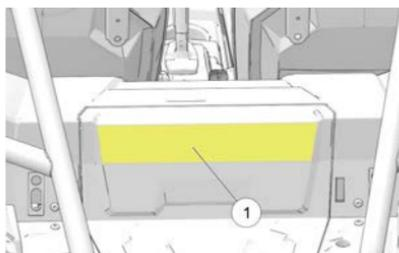

### WARNING

IMPROPER TIRE PRESSURE OR OVERLOADING CAN CAUSE LOSS OF CONTROL RESULTING IN SERIOUS INJURY OR DEATH.

- Reduce speed and allow greater distance for braking when carrying cargo.
- Overloading or carrying tall, off-center, or unsecured loads will increase your risk of losing control. Loads should be centered and carried as low as possible in box.
- For stability on rough or hilly terrain, reduce speed and cargo.
- Never carry passengers in cargo box.
- Passengers can be thrown off. This can cause serious injury or death.

	RZR	RZR S
<b>MAXIMUM CARGO BOX LOAD</b>	300 lbs. (136 kg)	300 lbs. (136 kg)
<b>TIRE PRESSURE IN PSI (KPa)</b>	FRONT 10 (69) REAR 12 (83)	FRONT 10 (69) REAR 14 (97)
<b>MAXIMUM WEIGHT CAPACITY INCLUDES WEIGHT OF OPERATOR, PASSENGERS, CARGO AND ACCESSORIES</b>	740 lbs. (336 kg)	740 lbs. (336 kg)
<b>Read Operation and Maintenance Manual for more detailed loading information.</b>		

## SAFETY WARNINGS

### WARNING

Failure to operate this vehicle properly can result in a collision, loss of control, accident or rollover, which may result in serious injury or death. Heed all safety warnings outlined in this section of the owner's manual and in the safety DVD provided with your vehicle. See the OPERATION section of the owner's manual for proper operating procedures.

## OPERATING WITHOUT INSTRUCTION

Operating this vehicle without proper instruction increases the risk of an accident. The operator must understand how to operate the vehicle properly in different situations and on different types of terrain. Take a training course and complete the steps outlined in the New Operator Driving Procedures section.

All operators must read and understand the owner's manual and all warning and instruction labels before operating the vehicle.

Never allow a guest to operate this vehicle until the guest has completed the steps outlined in the New Operator Driving Procedures section.

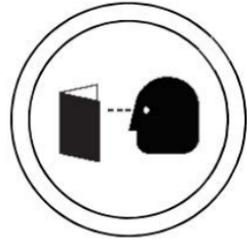

## SAFETY

---

### OPERATOR RESTRICTIONS / AGE RESTRICTIONS

This vehicle is an **ADULT VEHICLE ONLY**. Operation is prohibited for anyone under 16 years of age or anyone without a valid driver's license.

All operators and (if applicable) riders must be able to sit with backs against the seat, both feet flat on the floor and both hands on the steering wheel (if driving) or on a passenger hand hold.



### USING ALCOHOL OR DRUGS

Operating this vehicle after consuming alcohol or drugs could adversely affect operator judgment, reaction time, balance and perception.

Never consume alcohol or drugs before or while operating this vehicle.



### FAILURE TO INSPECT BEFORE OPERATING

#### WARNING

Failure to inspect and verify that the vehicle is in safe operating condition before operating increases the risk of an accident. Always perform the Pre-Ride Inspection outlined in the Operation chapter before each use of your vehicle to make sure it's in safe operating condition. Always follow the inspection and maintenance procedures and schedules described in this owner's manual. See the Periodic Maintenance section of the Maintenance chapter.

### SEAT BELTS

Riding in this vehicle without wearing the seat belt increases the risk of serious injury in the event of rollover, loss of control, other accident or sudden stop. Seat belts may reduce the severity of injury in these circumstances.

All riders *must* wear seat belts at all times.

---

## PROTECTIVE APPAREL

Riding in this vehicle without wearing an approved helmet and protective eyewear increases the risk of a serious injuries in the event of an accident. Operator and all passengers must always wear a helmet, eye protection, gloves, long-sleeve shirt, long pants and over-the-ankle boots.



## CAB DOORS

Riding in this vehicle without closed and latched cab doors increases the risk of serious injury or death in the event of an accident or rollover. Always make sure all cab doors are closed and latched while riding in this vehicle. Cab doors are NOT intended to be used as arm rests. *Keep hands and feet inside the vehicle at all times.*

## CARRYING MULTIPLE PASSENGERS (RZR 2-SEAT)

Never carry a passenger until you have operated this vehicle for at least two hours and have completed the steps in the New Operator Driving Procedures section. A passenger must always be seated in a passenger seat with seat belt secured. Carrying more than one passenger in a 2-seat vehicle can affect the operator's ability to steer and operate the controls, which increases the risk of loss of control and accident or rollover. Never carry more than one passenger in a 2-seat vehicle.



## SAFETY

### CARRYING MULTIPLE PASSENGERS (RZR 4-SEAT)

Never carry a passenger until you have operated this vehicle for at least two hours and have completed the steps in the New Operator Driving Procedures section.

A passenger must always be seated in a passenger seat with seat belt secured.

Never carry more than three passengers in a 4-seat vehicle.

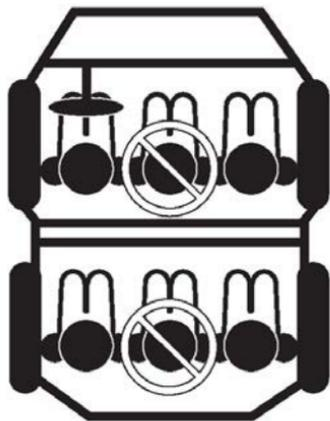

### OPERATING WITH A LOAD ON THE VEHICLE

The weight of both cargo and vehicle occupants impacts vehicle operation and stability. For your safety and the safety of others, carefully consider how your vehicle is loaded and how to safely operate the vehicle. Follow the instructions in this manual for loading, tire pressure, gear selection and speed.

- **Do not exceed vehicle weight capacities.** The vehicle's maximum weight capacity is listed in the specifications section of this manual and on a label on the vehicle. When more passenger weight is added, cargo weight may need to be reduced accordingly.
- The recommended tire pressures are listed in the specifications section of this manual and on a label on the vehicle.

**Always follow these guidelines:**

<b>Under ANY of these conditions:</b>	<b>Do ALL of these steps:</b>
Passenger and/or cargo exceeds half the maximum weight capacity	1. Slow down. 2. Verify tire pressure. 3. Use extra caution when operating.
Operating in rough terrain	
Operating over obstacles	
Climbing an incline	
Towing	

## PASSENGERS IN THE CARGO BOX

Carrying a passenger in the cargo box could result in a fall from the vehicle or contact with moving components. Never allow a passenger to ride in the cargo box. A passenger must always be seated in a passenger seat with seat belt secured.



## OPERATING ON PAVEMENT

This vehicle's tires are designed for off-road use, not for use on pavement. Operating this vehicle on paved surfaces (including sidewalks, paths, parking lots and driveways) may adversely affect the handling of the vehicle and may increase the risk of loss of control and accident or rollover. Avoid operating the vehicle on pavement. If it's unavoidable, travel slowly, travel short distances and avoid sudden turns or stops.

## OPERATING ON PUBLIC ROADS

Operating this vehicle on public streets, roads or highways could result in a collision with another vehicle. Never operate this vehicle on any public street, road or highway, including dirt and gravel roads (unless designated for off-highway use).



## OPERATING AT EXCESSIVE SPEEDS

Operating this vehicle at excessive speeds increases the operator's risk of losing control. Always operate at a speed that's appropriate for the terrain, the visibility and operating conditions, your skills and experience and any passenger's skills and experience.



## SAFETY

---

### TURNING IMPROPERLY

Turning improperly could cause loss of traction, loss of control, accident or rollover. Always follow proper procedures for turning as described in this owner's manual.

Avoid sharp turns. Never turn while applying heavy throttle. Never make abrupt steering maneuvers. Practice turning at slow speeds before attempting to turn at faster speeds.

### JUMPS AND STUNTS

Exhibition driving increases the risk of an accident or rollover. DO NOT do power slides, "donuts", jumps or other driving stunts. Avoid exhibition driving.



### IMPROPER HILL CLIMBING

Improper hill climbing could cause loss of control or rollover. Use extreme caution when operating on hills. Always follow proper procedures for hill climbing as described in this owner's manual. See the Driving Uphill section for details.



### DESCENDING HILLS IMPROPERLY

Improperly descending a hill could cause loss of control or rollover. Always follow proper procedures for traveling down hills as described in this owner's manual. See the Driving Downhill section for details.

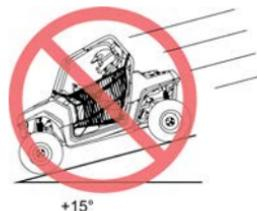

### CROSSING HILLSIDES

Driving on a sidehill is not recommended. Improper procedure could cause loss of control or rollover. Avoid crossing the side of any hill unless absolutely necessary.

If crossing a hillside is unavoidable, always follow proper procedures as described in this owner's manual. See the Driving on a Sidehill (Sidehilling) section for details.

## STALLING WHILE CLIMBING A HILL

Stalling or rolling backwards while climbing a hill could cause a rollover. Maintain a steady speed when climbing a hill.

*If you lose all forward speed:*

Apply the brakes gradually until the vehicle is fully stopped. Place the transmission in reverse and slowly allow the vehicle to roll straight downhill while applying light brake pressure to control speed.



## OPERATING IN UNFAMILIAR TERRAIN

Failure to use extra caution when operating on unfamiliar terrain could result in an accident or rollover. Unfamiliar terrain may contain hidden rocks, bumps, or holes that could cause loss of control or rollover. Travel slowly and use extra caution when operating on unfamiliar terrain. Always be alert to changing terrain conditions.



## OPERATING IMPROPERLY IN REVERSE

Improperly operating in reverse could result in a collision with an obstacle or person. Always follow proper operating procedures as outlined in this manual. See the Driving in Reverse section for details. Before shifting into reverse gear, always check for obstacles or people behind the vehicle. When it's safe to proceed, back slowly.



## IMPROPER TIRE MAINTENANCE

Operating this vehicle with improper tires or with improper or uneven tire pressure could cause loss of control, accident or rollover.

Always use the size and type of tires specified for your vehicle. Always maintain proper tire pressure as described in this owner's manual and on safety labels.

## SAFETY

---

### SKIDDING OR SLIDING

Failure to use extra caution when operating on excessively rough, slippery or loose terrain could cause loss of traction, loss of control, accident or rollover. Do not operate on excessively slippery surfaces. Always slow down and use additional caution when operating on slippery surfaces.

Skidding or sliding due to loss of traction can cause loss of control or rollover (if tires regain traction unexpectedly). Always follow proper procedures for operating on slippery surfaces as described in this owner's manual. See the Driving on Slippery Surfaces section for details.

### OPERATING OVER OBSTACLES

Improperly operating over obstacles could cause loss of control or rollover.

Before operating in a new area, check for obstacles. Never attempt to operate over large obstacles such as large rocks or fallen trees. Always follow the proper procedures outlined in this manual when operating over obstacles. See the Driving Over Obstacles section for details.



### OPERATING THROUGH WATER

Operating through deep or fast-flowing water can cause loss of traction, loss of control, rollover or accident. Never operate in fast-flowing water or in water that exceeds the floor level of the vehicle.

Always follow proper procedures for operating in water as described in this owner's manual. See page 91.



Wet brakes may have reduced stopping ability. After leaving water, test the brakes. Apply them lightly several times while driving slowly. The friction will help dry out the pads.

---

## OPERATING ON FROZEN BODIES OF WATER

Severe injury or death can result if the vehicle and/or the operator fall through the ice. Never operate the vehicle on a frozen body of water unless you have first verified that the ice is sufficiently thick to support the weight and moving force of the vehicle, you and any passengers, and your cargo, together with any other vehicles in your party.



Always check with local authorities and residents to confirm ice conditions and thickness over your entire route. Vehicle operators assume all risk associated with ice conditions on frozen bodies of water.

## OPERATING A DAMAGED VEHICLE

Operating a damaged vehicle can result in an accident. After any rollover or other accident, have a qualified service dealer inspect the entire machine for possible damage, including (but not limited to) seat belts, rollover protection devices, brakes, throttle and steering systems.

## REFUELING

Gasoline is highly flammable and explosive under certain conditions.

- Always exercise extreme caution whenever handling gasoline.
- Always turn off the engine when refueling.
- Always refuel outdoors or in a well ventilated area free of any source of flame or sparks.
- NEVER carry fuel or other flammable liquids on this vehicle. Failure to follow this instruction could lead to serious burn injuries or death.
- Do not smoke or allow open flames or sparks in or near the area where refueling is performed or where gasoline is stored.
- Do not overfill the tank. Do not fill the tank neck.
- If gasoline spills on your skin or clothing, immediately wash it off with soap and water and change clothing.

## EXPOSURE TO EXHAUST

Engine exhaust fumes are poisonous and can cause loss of consciousness or death in a short time. Never start the engine or let it run in an enclosed area.

Operate this vehicle only outdoors or in well-ventilated areas.

## SAFETY

---

### HOT EXHAUST SYSTEMS



Exhaust system components are very hot during and after use of the vehicle. Hot components can cause burns and fire. Do not touch hot exhaust system components. Always keep combustible materials away from the exhaust system.

Use caution when traveling through tall grass, especially dry grass and when traveling through muddy conditions. Always inspect the underside of the vehicle and areas near the exhaust system after driving through tall grass, weeds, brush, other tall ground cover, and muddy conditions. Promptly remove any grass, debris or foreign matter clinging to the vehicle and pay particular attention to the exhaust system area.

### IMPROPER CARGO LOADING

Overloading the vehicle or carrying cargo improperly may cause changes in stability and handling, which could cause loss of control or an accident.



- Always follow the instructions in this owner's manual for carrying cargo. See page 96.
- Never exceed the stated load capacity for this vehicle. See the Load / Passenger / Tire Pressure Warning section for details.
- Cargo should be properly distributed and securely attached. See page 96.
- Reduce speed when carrying cargo. Allow a greater distance for braking.

### UNAUTHORIZED USE OF THE VEHICLE

Leaving the keys in the ignition can lead to unauthorized use of the vehicle by someone under the age of 16, without a drivers license, or without proper training. This could result in an accident or rollover. Always remove the ignition key when the vehicle is not in use.

## EQUIPMENT MODIFICATIONS

Your POLARIS vehicle is designed to provide safe operation when used as directed. Modifications to your vehicle may negatively impact vehicle stability. Failure of critical machine components may result from operation with any modifications, especially those that increase speed or power. This vehicle may become less stable at speeds higher than those for which it is designed. Loss of control may occur at higher speeds.

Do not install any non-POLARIS-approved accessory or modify the vehicle for the purpose of increasing speed or power. Any modifications or installation of non-POLARIS-approved accessories could create a substantial safety hazard and increase the risk of bodily injury.

The POLARIS limited warranty on your POLARIS vehicle will be terminated if any non-POLARIS-approved equipment and/or modifications have been added to the vehicle that increase speed or power.

The addition of certain accessories, including (but not limited to) mowers, blades, tires, sprayers, or large racks, may change the handling characteristics of the vehicle. Use only POLARIS-approved accessories, and familiarize yourself with their function and effect on the vehicle.

The addition of certain accessories, including (but not limited to) overhead audio speakers, may change the forward clearance in the vehicle. Polaris recommends selecting a helmet that is compatible with the equipment on your vehicle and provides the greatest amount of forward clearance. Always wear a helmet that meets or exceeds the specifications in this owner's manual. Refer to the Safe Riding Gear section of this owner's manual for more information. Use only POLARIS-approved accessories.

**FOR MORE INFORMATION ABOUT SAFETY  
call POLARIS at 1-800-342-3764.**



# FEATURES AND CONTROLS

## COMPONENT LOCATIONS

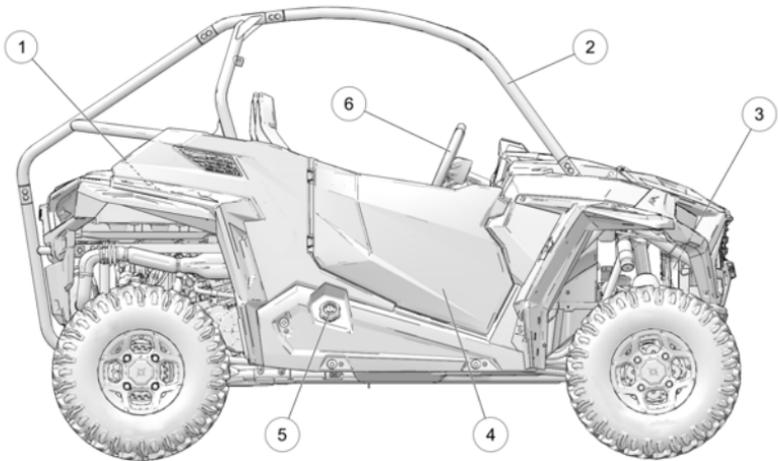

- ① Cargo Box
- ② ROPS Frame
- ③ Radiators

- ④ Cab Door
- ⑤ Fuel Tank Cap
- ⑥ Steering Wheel

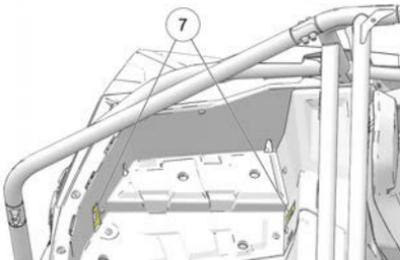

- ⑦ Tie-Down Points (4 corners)

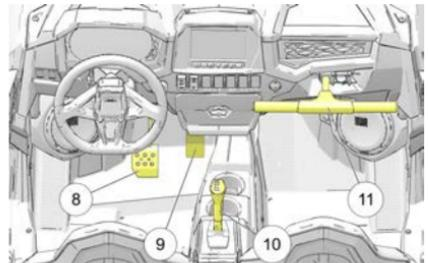

- ⑧ Brake Pedal
- ⑨ Throttle Pedal
- ⑩ Gear Selector
- ⑪ Passenger Hand Hold

### SWITCHES

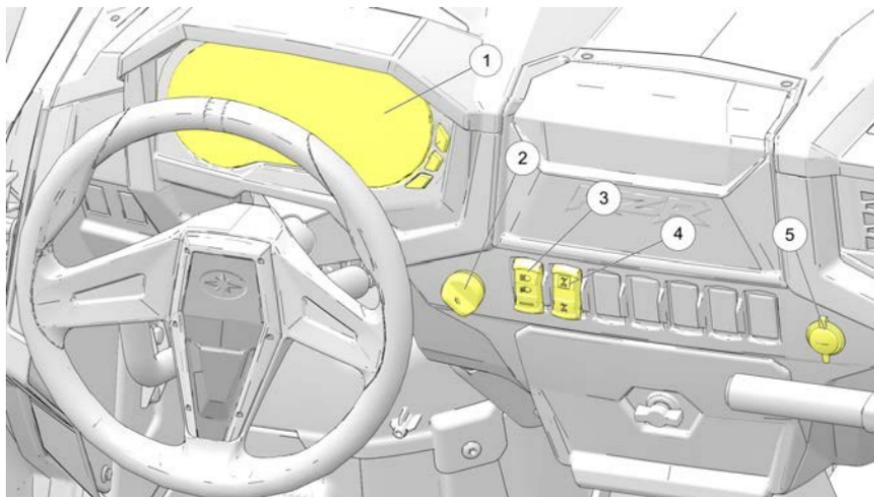

① Instrument Cluster

② Ignition Switch

③ Headlight Switch

④ All Wheel Drive (AWD) Switch

⑤ 12V Accessory Outlet

## IGNITION SWITCH

The ignition switch is a four-position, key-operated switch. Use the ignition switch to start the engine. See page 84 for starting procedures.

POSITION	FUNCTION
OFF	The engine is off. Electrical circuits are off, except accessory 12V.
ACCESSORY	The engine is off. Powers the gauge and terminal block. Check engine and power steering warning indicators will appear on the gauge in this mode but will turn off when the vehicle is started if no issues are present.
ON	Electrical circuits are on. Electrical equipment can be used.
START	Turn the key to the START position to engage the electric starter. The key returns to the ON position when released.

The key can be removed from the switch when it is in the OFF position.

## ALL WHEEL DRIVE (AWD) SWITCH

The AWD Switch has either two or three positions, depending on your model's features:

- ① All Wheel Drive (AWD)
- ② Two Wheel Drive (2WD)
- ③ Turf Mode / Differential Unlocked (1WD)

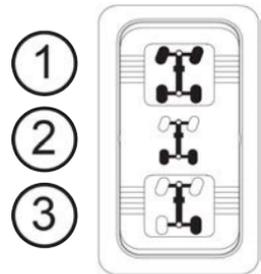

See the All Wheel Drive (AWD) System section for operating instructions.

## FEATURES AND CONTROLS

---

### HEADLIGHT SWITCH

Use the headlight switch to turn the lights on and off and to change the lights from high beam to low beam. The ignition switch must be in the ON position to operate the headlights.

Press the top of the rocker switch toward the dash to place the headlights on high beam ①. Move the rocker switch to the center position to place the headlights on low beam ②. Press the bottom of the rocker switch to turn off the headlights.

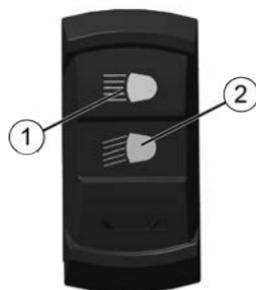

If the headlight switch is ON when the ignition switch is turned off, the lights will remain on for approximately 30 seconds.

### ELECTRONIC POWER STEERING (EPS)

Electronic power steering (if equipped) engages when the ignition key is turned to the ON position. EPS remains engaged whether the vehicle is moving or idle.

The EPS warning indicator briefly illuminates when the key is turned to the ON position. See the Instrument Cluster section for details.

To conserve battery power, the EPS will shut down 5 minutes after the engine is stopped if the key remains in the ON position. The EPS warning indicator will illuminate to indicate the EPS has shut down.

If the light remains on after starting the engine, the EPS system is inoperative. See your POLARIS dealer, or other qualified person, as soon as possible for repair. Continued operation could result in permanent damage to the EPS unit and increased steering effort.

### AUXILIARY OUTLETS

The vehicle is equipped with one or more 12-volt accessory outlets. One outlet is on the dash, a second outlet (if equipped) is in the rear passenger area. Use the outlets to power an auxiliary light or other optional accessories. For service, the dash outlet connection is under the dash. The rear outlet connection is under the rear passenger seats.



### STEERING WHEEL

The steering wheel can be tilted upward or downward for rider preference. Lift and hold the steering wheel adjustment lever ① while moving the steering wheel upward or downward. Release the lever when the steering wheel is at the desired position.

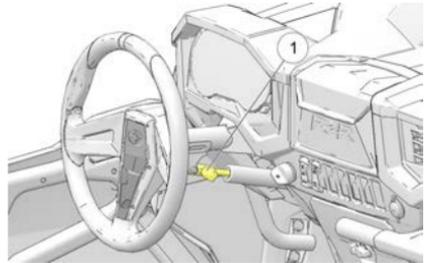

### SEATS

Before operating the vehicle, always push down on all seat backs to ensure the latches are secure.

### SEAT ADJUSTMENTS

On seats equipped with an adjustment lever under the front edge of the seat, pull the lever to the left. Slide the seat forward or rearward to the desired position. Release the lever. The seat will lock into the new position.

For other seat styles, loosen (do not remove) the four screws located on the seat bottom. Slide the seat forward or rearward to the desired position. Tighten the screws to 4 ft-lbs (5.4 N·m). Do not overtighten.

### SEAT REMOVAL

1. Pull up on the seat latch ① lever located under the rear edge of the seat.

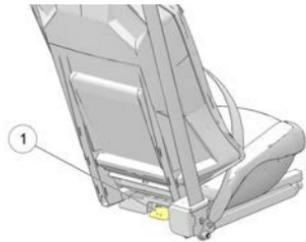

2. Tilt the seat forward.
3. Lift the seat upward to remove it from the vehicle.
4. Reverse this procedure to reinstall the seat. Make sure the seat tabs at the front edge of the seat slide under the seat retainer bar.
5. Press down firmly at the rear of the seat to engage the rear latch.

## FEATURES AND CONTROLS

---

### FUEL CAP

The fuel tank filler cap ① is located on the right-hand side of the vehicle near the passenger seat. When refueling, always use either leaded or unleaded gasoline with a minimum pump octane number of 87 R+M/2 octane. *Do not use fuel with ethanol content greater than 10 percent, such as E-85 fuel.* To close, tighten the fuel cap until it clicks twice.

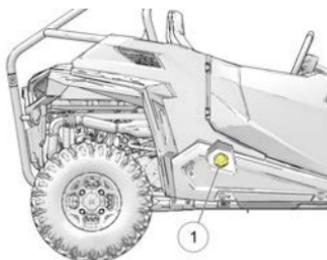

### CAB DOORS

This vehicle is equipped with cab doors. Riding in this vehicle without closed and latched cab doors increases the risk of serious injury or death in the event of an accident or rollover. Always make sure all cab doors are closed and latched when riding in this vehicle.

Always inspect doors and latches for wear and damage before each use of the vehicle.

Promptly replace any worn or damaged parts with new parts available from your authorized POLARIS dealer or qualified person.

### HOOD

Remove the hood to access the radiator pressure cap ② and coolant overflow bottle ③.

1. Turn the hood fasteners ① 1/4 turn.
2. Grasp the upper hood edge and pull upward to disengage the fasteners.
3. Pivot the hood forward and lift upward to disengage the lower hood hooks.
4. Lift the hood away from the vehicle.

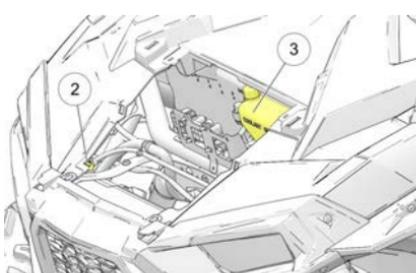
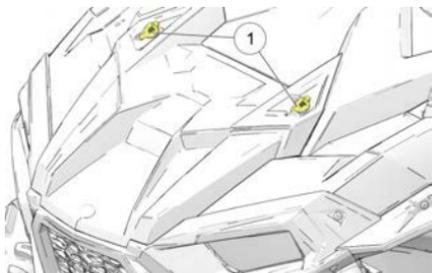

### ROLLOVER PROTECTIVE STRUCTURE (ROPS)

The Rollover Protective Structure (ROPS) on this vehicle meets ISO 3471 rollover performance requirements. Always have your authorized dealer thoroughly inspect the ROPS if it ever becomes damaged in any way.

① ROPS Label (on ROPS or pass. hip bar)

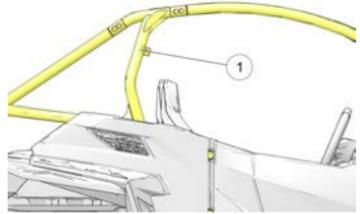

#### WARNING

Never make modifications to the vehicle's ROPS structure.

*No device can assure occupant protection in the event of a rollover.* When used with seat belts and cab nets or doors, the ROPS helps prevent occupants from being ejected from the vehicle. Always follow all safe operating practices outlined in this manual to avoid vehicle rollover.

#### WARNING

Vehicle rollover could cause severe injury or death. Always avoid operating in a manner that could result in vehicle rollover.

### BRAKE AND THROTTLE PEDALS

#### BRAKE PEDAL

Depress the brake pedal ① to slow or stop the vehicle. Apply the brakes while starting the engine.

#### THROTTLE PEDAL

Push the throttle pedal ② down to increase engine speed. Spring pressure returns the pedal to the rest position when released. Always check that the throttle pedal returns normally before starting the engine.

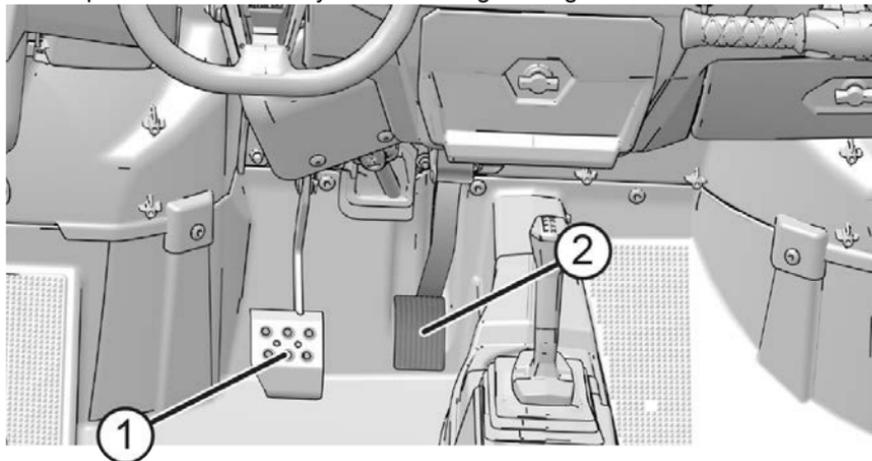

#### TIP

If the throttle pedal and brake pedal are applied simultaneously, engine power may be limited.

### TRAILER RECEIVER HITCH BRACKET

This vehicle is equipped with a receiver hitch bracket for a trailer hitch. Trailer towing equipment is not supplied with this vehicle.

To avoid injury and property damage, always heed the warnings and towing capacities outlined in the Hauling Cargo section or the Towing section.

### GEAR SELECTOR

P: Park

R: Reverse

N: Neutral

L: Low Gear

H: High Gear

To change gears, stop the vehicle, and with the engine idling, move the lever ① to the desired gear. Do not attempt to shift gears with engine speed above idle or while the vehicle is moving.

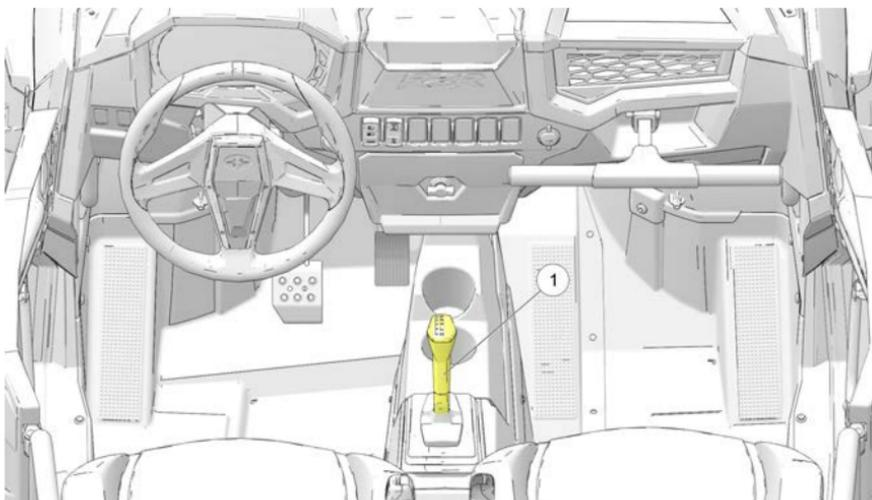

#### TIP

Maintaining shift linkage adjustment is important to assure proper transmission function. Your POLARIS dealer or qualified person can assist in resolving any shifting problems.

#### NOTICE

Do not attempt to shift the transmission while the vehicle is moving or damage to the transmission could result. Always shift when the vehicle is stationary and the engine is at idle.

### USING LOW RANGE

Always shift into low gear for any of the following conditions:

## FEATURES AND CONTROLS

---

- Operating in rough terrain or over obstacles
- Loading the vehicle onto a trailer
- Towing heavy loads

## SERVICE ACCESS PANELS

### ENGINE ACCESS PANEL

The engine access panel is located behind the seats on the frame of the vehicle. Remove the seats and remove the access panel to reach serviceable engine components.

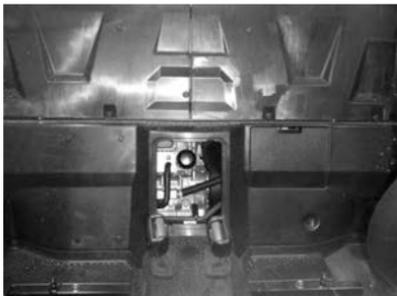

### CARGO BOX ACCESS PANEL

The cargo box access panel is located on the floor of the cargo box. Remove the panel to access the engine oil fill cap, spark plugs and air filter.

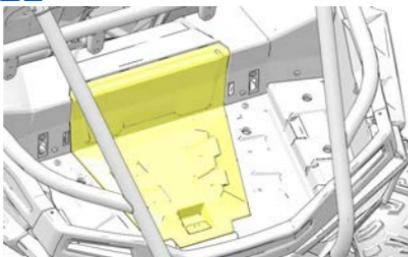

### PASSENGER HAND HOLD

Always adjust the hand hold to a comfortable position for your passenger before operating. Make sure the adjustment pin and retainer are securely installed after making adjustments.

1. Remove the retainer ① from the end of the adjustment pin ②.
2. Remove the pin from the post.
3. Slide the post inward or outward to the desired position.
4. Reinstall the pin through the post mounting hole ③, adapter bushing hole ④, both post adjustment holes ⑤, and lastly through the remaining bushing hole and post mounting hole.

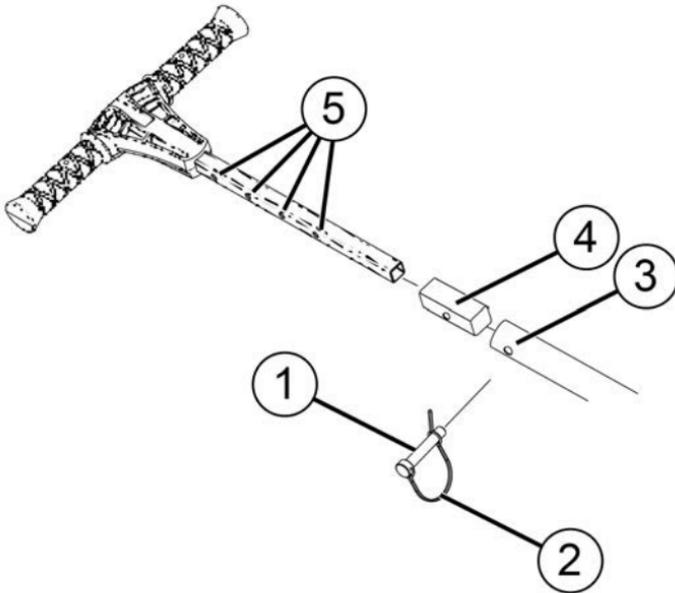

5. Reinstall the retainer to the pin.

### **SEAT BELTS**

This POLARIS vehicle is equipped with seat belts for all riders. Always make sure the seat belts are secured for the operator and all passengers before riding. The driver's seat belt is equipped with a seat belt interlock. Vehicle speed will be limited to 15 mph (24 km/h) if the seat belt is not secured.

#### **3-POINT SEAT BELT**

To wear the 3-point seat belt properly, follow this procedure:

1. Pull the seat belt latch downward and across your chest toward the buckle at the inner edge of the seat. The belt should fit snugly across your hips and diagonally across your chest. Make sure the belt is not twisted.
2. Push the latch plate into the buckle until it clicks. Pull up on the strap to tighten.
3. Press the red release latch on the buckle to release the seat belt.

### SEAT BELT INSPECTION

Inspect all seat belts for proper operation before each use of the vehicle.

1. Push the latch plate into the buckle until it clicks. The latch plate must slide smoothly into the buckle. A click indicates that it's securely latched.
2. Push the red release latch in the middle of the buckle to make sure it releases freely.
3. Pull each seat belt completely out and inspect the full length for any damage, including cuts, wear, fraying or stiffness. If any damage is found, or if the seat belt does not operate properly, have the seat belt system checked and/or replaced by an authorized POLARIS dealer or qualified person.
4. To clean dirt or debris from the seat belts, sponge the straps with mild soap and water. Do not use bleach, dye or household detergents. Rinse the entire length of the belt webbing. Use a garden hose to flush out the latch ① and retractor ② housings regularly.

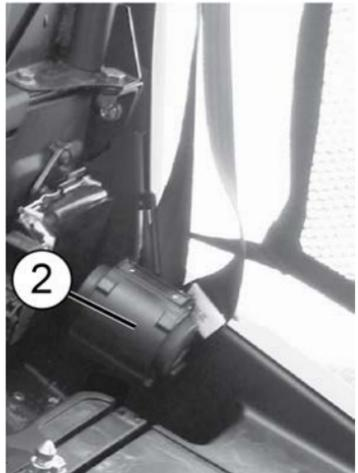

## FEATURES AND CONTROLS

### SEAT BELT HEIGHT ADJUSTER (IF EQUIPPED)

The seat belt height adjuster reduces neck rub and works as a shock absorber for your shoulder. The height adjuster consists of an adjuster ① and a rail ②. Adjustment becomes easier with repeated use. The seat belt height adjuster can be cleaned with water.

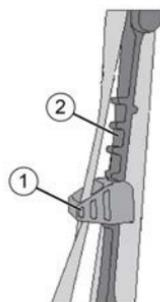

To adjust the height of your seat belt for desired comfort and proper fit, follow this procedure:

1. Stretch the seat belt height adjuster toward the front of the vehicle.
2. While continuing to stretch the seat belt height adjuster, slide the adjuster up or down, rocking it side to side if necessary, until you reach the desired height. This may require both hands. Do not attempt to adjust while vehicle is in motion.

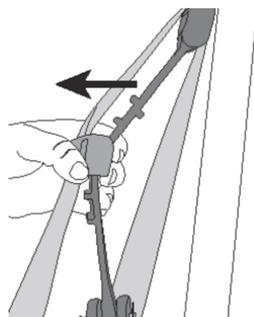

Proper location  
of shoulder belt



Wrong



Wrong

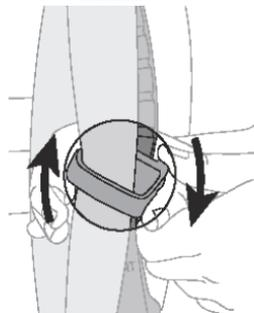

## ALL WHEEL DRIVE (AWD) SYSTEM

The All Wheel Drive system is controlled by the AWD switch. The switch has two positions, AWD (4x4) and 2WD (2x4). The switch on models equipped with a lockable differential has a third position for unlocking the differential. When unlocked, only one rear wheel is a drive wheel.

- ① All Wheel Drive (AWD)
- ② Two Wheel Drive (2WD)
- ③ Turf Mode / Differential Unlocked (1WD)

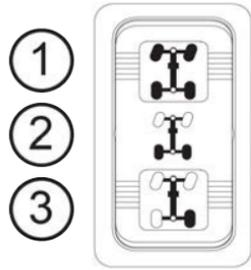

When the switch is on 2X4, the vehicle is in two-wheel drive at all times. When the switch is on AWD, the vehicle is in all wheel drive and the 4X4 indicator in the instrument cluster will be on.

When in AWD, the demand drive unit will automatically engage any time the rear wheels lose traction. When the rear wheels regain traction, the demand drive unit will automatically disengage.

There is no limit to the length of time the vehicle may remain in AWD.

## ENGAGING AWD

The AWD switch may be turned on or off while the vehicle is moving. Initially, the vehicle's electronic system will not enable the AWD until the engine RPM is below 3100. Once enabled, the AWD remains enabled until the AWD switch is turned off. If the switch is turned off while the demand drive unit is moving, it will not disengage until the rear wheels regain traction.

Engage the AWD switch before getting into conditions where front wheel drive may be needed. If the rear wheels are spinning, release the throttle before switching to AWD.

### NOTICE

Switching to AWD while the rear wheels are spinning or slipping may cause severe drive shaft and gearcase damage. Always switch to AWD while the rear wheels have traction or are at rest.

## FEATURES AND CONTROLS

### DISENGAGING AWD

Move the AWD switch to the center or bottom position to disengage AWD. If the switch is turned off while the front hubs are driving, they will not release until the rear wheels regain traction.

In some situations, the front gearcase may remain locked after turning the AWD switch off. If this occurs, you may notice increased steering effort and some vehicle speed restriction. Perform the following procedure to unlock the front gearcase.

1. Stop the vehicle.
2. Operate in reverse for at least 10 ft (3 m).
3. Stop completely.
4. Shift into low gear and drive forward.
5. If the front gearcase remains locked after following these instructions, see your dealer for service.

### LOCKING/UNLOCKING THE DIFFERENTIAL (IF EQUIPPED)

#### NOTICE

Damage to the differential can occur if it is engaged while the vehicle is traveling at high speeds or while the rear wheels are spinning. Slow the vehicle to nearly stopped before engaging the differential.

Locking the differential in slippery or low traction conditions helps improve traction. Move the rocker switch to the center position (2WD) to lock the differential and operate in rear wheel drive.

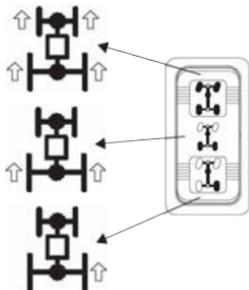

Press the bottom of the switch to unlock the differential and allow the rear drive wheels to operate independently. This mode of operation is well suited to turf driving or whenever aggressive traction is not required.

### **RIDE COMMAND DISPLAY (IF EQUIPPED)** **BEFORE YOU RIDE**

Before riding with your new display, do the following:

- Read this entire manual.
- Familiarize yourself with the features and operations of the Display while the vehicle is stationary.
- Download the Polaris RIDE COMMAND App from the Apple®/Google Play® store and create your personalized account.
- Check your display to ensure you have the appropriate maps and trails visible for your area. To change or update maps/trails see page 54.
- Check <https://www.polaris.com/en-us/owners-manuals/> for the latest updates to the owner's manual.

#### NOTICE

Trails change often, and the trail data file is only considered valid for 90 days after the release date. Please keep your trail data up to date. Download the latest trails at <http://ridecommand.polaris.com>.

#### NOTICE

Using the display for an extended period of time while the vehicle's engine is off can drain the battery.

### **DEVICE OPERATING REQUIREMENTS**

Phone functionality is dependent on the capabilities of your cell phone.

#### NOTICE

Some cell phones or operating systems will not work as shown in this manual.

### **RADIO COMPLIANCE STATEMENTS**

*The following statements apply to radio components offered with this vehicle. These include but may not be limited to the touchscreen display.*

This device complies with part 15 of the FCC Rules. Operation is subject to the following two conditions: (1) This device may not cause harmful interference, and (2) this device must accept any interference received, including interference that may cause undesired operation.

This device complies with FCC RF radiation exposure limits for general population.

## FEATURES AND CONTROLS

---

This device contains license-exempt transmitter(s)/receiver(s) that comply with Innovation, Science and Economic Development Canada's license-exempt RSS (s). Operation is subject to the following two conditions:

1. This device may not cause interference.
2. This device must accept any interference, including interference that may cause undesired operation of the device.

### CAUTION

This equipment complies with part 15 of the Federal Communications Commission (FCC) rules.

These requirements are intended to provide reasonable protection against harmful interference in a residential installation. This equipment generates, uses and can radiate radio frequency energy and, if not installed and used in accordance with the instructions, may cause harmful interference to radio communications. However, there is no guarantee that interference will not occur in a particular installation.

If this equipment does cause harmful interference to radio or television reception, which can be determined by turning the equipment off and on, the user is encouraged to try to correct the interference by one or more of the following measures:

- Reorient or relocate the receiving antenna.
- Increase the separation between the equipment and receiver.
- Connect the equipment into an outlet on a circuit different from that to which the receiver is connected.
- Consult the dealer or an experienced radio/TV technician for help.

Changes or modifications to this equipment not expressly approved by the party responsible for compliance could void the user's authority to operate the equipment.

This vehicle contains the following radio equipment or components that contain radio equipment:

COMPONENT	COMPONENT ID	MANUFACTURER
9200 Series Display	RC7	Polaris Industries Inc.

Hereby, Polaris, Inc. declares that the above radio equipment is in compliance with EU Directive 2014/53/EU.

The full text of the EU declaration of conformity is available at the following internet address:

<https://www.polaris.com/en-us/radio-conformity/>

## VEHICLE-TO-VEHICLE COMMUNICATION (V2V)

### IMPORTANT

For applications that use vehicle-to-vehicle (V2V) communication, radio transmitter IC: 5966A-P001 has been approved by Innovation, Science and Economic Development Canada (ISED) to operate with the Polaris antenna (part number 4018713) with gain of 3 dBi. Any antenna that has a gain greater than 3 dBi is prohibited for use with this device.

## OVERVIEW



- ① Ride Command Buttons
- ② Driveline Mode
- ③ Widgets
- ④ Settings

- ⑤ Icon Bar
- ⑥ Gauge View Mode
- ⑦ Speedometer/Tachometer
- ⑧ Gear Status

## FEATURES AND CONTROLS

### RIDE COMMAND BUTTONS

BUTTON	DESCRIPTION	FUNCTION
	Menu/Power Button	Press the Menu/Power button to access the settings. To reboot the display, press and hold for 5 seconds.
	Gauge Screen Button	Press the Gauge Screen button to select from available screens.
	Map Button	Press the Map button to access the map, manage your rides and waypoints, and to see your friends on the map with Group Ride.
	Phone Button	Press the Phone button to access your Bluetooth® connected phone, including recent calls, contacts, dialer, and messages.
	Audio Button	Press the Audio button to access the Radio, Weather, USB, and connected Bluetooth® music interface

## FEATURES AND CONTROLS

BUTTON	DESCRIPTION	FUNCTION
	Volume Decrease Button	Press the Volume Decrease button to decrease the volume. Press and hold to mute volume.
	Volume Increase Button	Press the Volume Increase button to increase the volume.

## FEATURES AND CONTROLS

### DRIVELINE MODE

INDICATOR	DESCRIPTION	FUNCTION
	2WD	When the switch is on 2X4, the vehicle is in two-wheel drive at all times.
	AWD	When in All-Wheel Drive, the demand drive unit will automatically engage any time the rear wheels lose traction. When the rear wheels regain traction, the demand drive unit will automatically disengage. There is no limit to the length of time the vehicle may remain in 4X4. The vehicle automatically engages 4X4 when operating in reverse if the switch is set to 4X4 position.
	Turf Mode (if equipped)	When operating in TURF mode, the inside rear wheel will rotate independently from the outside wheel during turns. Operate in TURF mode only as needed to protect smooth, level surfaces from tire damage. DO NOT operate in TURF mode when climbing or descending hills, when sidehilling, or when operating on uneven, loose, or slippery terrain such as sand, gravel, ice, snow, obstacles, and water crossings. Always operate in AWD on these types of terrain.

## GAUGE SCREENS

Press the Gauge Screen button to toggle between gauge screens. The display comes loaded with two different gauge screens. Additional gauge screens can be added or deleted.

Each gauge screen is customizable and can be set up in the following configurations:

- Four round widgets
- Two round widgets and a list of three data values
- A list of five data values

To customize your gauge screens, press the gear icon located in the lower right corner of the display.



## SETTINGS

From the setting menu you can view vehicle information, manage Bluetooth® devices, update display software, and more.

To access the Setting menu, press the Menu/Power button ①.

You can also navigate to the settings menu by pressing the POLARIS logo at the top of the display screen ②. This will open the Control Panel. From the Control Panel, select the settings tab, then press the **All Settings** button located in the lower right corner of the display screen.



## FEATURES AND CONTROLS

### GAUGE VIEW MODE

Press ① to toggle between the two available gauge view modes, **Analog** and **Digital**.

While in the digital gauge view mode, press ② to invert the MPH and RPM units.



### ICON BAR



ICON	DESCRIPTION	FUNCTION
①	Headset	Displays icon if headset is connected
②	Signal Strength	Displays current cell signal strength
③	Fuel Level	Displays current fuel capacity percentage
④	Vehicle Direction	Displays vehicle direction

ICON	DESCRIPTION	FUNCTION
⑤	Ambient Temperature	Displays ambient temperature
⑥	Clock	Displays current time

## UPDATE SOFTWARE

### NOTICE

Before updating the Display, always export your existing rides and waypoints to a USB drive to avoid losing them.

To update the software, do the following:

### **ON YOUR PERSONAL COMPUTER**

1. Go to [ridecommand.polaris.com/update](http://ridecommand.polaris.com/update).
2. Log into your account, or create a new account.
3. Using the Vehicle Identification Number (VIN), add your new Polaris vehicle to your Garage.
4. Locate and download the latest software to a USB flash drive (8+ GB).

### **ON YOUR VEHICLE**

1. Connect the USB flash drive to the USB cable and power up your vehicle.
2. On the RIDE COMMAND display, select the Settings menu on your display by pressing the POLARIS icon at the top of the screen.
3. Select General Settings, then Update Software.
4. Select the file you wish to load (use date listed in the file name to determine most recent file).
5. Select Yes to restart display (restart required).

### **ERROR MESSAGES**

If an error occurs while updating your software, perform one or all of the following actions to resolve the issue:

1. Remove and reconnect the USB flash drive securely.
2. Make sure the display files are not inside a folder on the flash drive.
3. Make sure only display files are on the flash drive. Remove any other files if necessary.
4. Try using a different USB flash drive.

## FEATURES AND CONTROLS

---

### UPDATE MAPS

To update the maps on your display, do the following:

1. Go to [ridecommand.polaris.com/update](http://ridecommand.polaris.com/update) and download the map update to a USB flash drive.
2. Insert USB flash drive into the USB port on your vehicle.
3. Press the Update maps in the General Settings.
4. Select the file you want to install by pressing the corresponding down arrow icon.
5. This will update the display's map which will automatically restart the display once the update is complete. Do not remove the USB flash drive until the display has fully restarted.

### USB HARDWARE

#### **SOFTWARE UPDATES**

For software update, POLARIS recommends using a SanDisk® or similar USB flash drive with a minimum of 4GB in available memory, formatted using the FAT32 or exFAT file systems. For best results remove all files from the flash drive before starting the update process.

#### **MAP UPDATES**

For Map updates, a 32GB USB drive is required (USB 3.0 drive is highly recommended) USB drive must be formatted to exFAT before copying the map file onto it.

#### **TRAIL UPDATES**

For Trail updates, a 4GB drive formatted to FAT32 can be used.

## INSTRUMENT CLUSTER

### NOTICE

High water pressure may damage components. Wash the vehicle by hand or with a garden hose using mild soap. Certain products, including insect repellents and chemicals, will damage the speedometer lens and other plastic surfaces. Do not use alcohol to clean the instrument cluster. Do not allow insect sprays to contact the lens. Immediately clean off any gasoline that splashes on the instrument cluster.



- ① Speedometer
- ② Tachometer
- ③ Indicator Lamps

- ④ Mode Button
- ⑤ Toggle Buttons
- ⑥ Rider Information Center

## FEATURES AND CONTROLS

---

### SPEEDOMETER

The speedometer displays vehicle speed in either miles per hour (MPH) or kilometers per hour (km/h).

### TACHOMETER

The tachometer displays engine speed in revolutions per minute (RPM).

### MODE AND TOGGLE BUTTONS

Press and hold the MODE button ④ to enter or exit the settings menu. Press and release the MODE button to cycle through Area 1 modes and to select an item.

Press and release either toggle button ⑤ to cycle through the options menu or Area 2 modes. Press and hold either toggle button to reset an item. See page 60.

#### TIP

With the ignition key off, pressing the MODE button or either toggle button will power up the Rider Information Center for 10 seconds to allow viewing of the odometer and the clock.

## INDICATOR LAMPS

LAMP	INDICATES	CONDITION
	Check Engine	This indicator appears if an EFI related fault occurs. Do not operate the vehicle if this warning appears. Serious engine damage could result. Your authorized dealer can assist.
	EPS Warning (if equipped)	This indicator illuminates briefly when the key is turned to the ON position. If the light remains on, the EPS system is inoperative. See your POLARIS dealer, or another qualified person, as soon as possible for repair. Continued operation could result in permanent damage to the EPS unit and increased steering effort.
	Engine Hot	This lamp illuminates to indicate an overheated engine. If the indicator flashes, a severe overheating condition exists.
	Neutral	This lamp when the transmission is in neutral and the ignition key is on the ON position.
	Helmet / Seat Belt	This lamp flashes for several seconds when the key is turned to the ON position. The lamp is a reminder to wear helmet and seat belt before operating.
	High Beam	This lamp illuminates when the headlamp switch is set to high beam.
	Chassis Fault	Not applicable.
	Performance Limited	Not applicable.

## FEATURES AND CONTROLS

### RIDER INFORMATION CENTER

The rider information center is located in the instrument cluster. All segments will light up for one second at start-up.

If the instrument cluster fails to illuminate, a battery over-voltage may have occurred and the instrument cluster may have shut off to protect the electronic speedometer. If this occurs, your POLARIS dealer can provide proper diagnosis.

The information center is set to display standard units of measurement and a 12-hour clock at the factory. To change to metric and/or a 24-hour clock, see the Clock section.

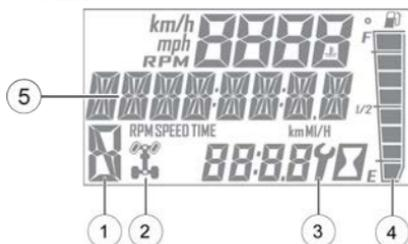

①	Gear Indicator	This indicator displays gear shifter position H = High Gear L = Low Gear N = Neutral R = Reverse Gear P = Park - = Gear Signal Error (or shifter between gears)
②	AWD Indicator	This indicator shows whether 2X4 or AWD is active when the vehicle is in gear.
③	Service Indicator	A flashing wrench symbol alerts the operator that the preset service interval has been reached. Your POLARIS dealer can provide scheduled maintenance. See page 63 for resetting instructions.
④	Fuel Gauge	The segments of the fuel gauge show the level of fuel in the fuel tank. When the last segment clears, a low fuel warning is activated. The outline of the fuel display will flash. Refuel immediately.
⑤	Speed Limitation (if equipped)	This vehicle may be equipped with a maximum speed limitation function. This would be displayed on the screen as "LIM" followed by the speed. "LIM 30" for example.

## MODE INFORMATION DISPLAYS

The rider information center contains three areas that display mode information.



① Area 1 Modes	Description
Engine Temperature	Temperature of engine coolant
Vehicle Speed	Speed of vehicle
Tachometer	Engine speed (RPM)
② Area 2 Modes	Description
Odometer	The odometer records and displays the distance traveled by the vehicle.
Trip Meters (T1/T2)	A trip meter records the distance traveled by the vehicle if reset before each trip. To reset, see page 62.
Engine Hours	Total hours of engine operation since manufacture
Service Hours	A flashing wrench symbol indicates that the preset service interval has been reached. To reset, see page 63.
Trip Time	Time length of vehicle operation since mode was last reset
③ Area 3 Modes	Description
Clock	The clock displays time in a 12-hour or 24-hour format. To reset, see page 61.

## FEATURES AND CONTROLS

---

### ACCESSING MENUS AND OPTIONS

#### **GAUGE SETTINGS MENU**

Press and release the MODE button to cycle through the Area 1 modes until the desired default mode displays. See the Mode Information Displays section for details.

Press and hold the MODE button to enter the settings menu.

*The OPTIONS screen will display for a few seconds.*

1. Press and release either toggle button to cycle to the desired option.
2. Press MODE to select the option.
3. Press either toggle button to cycle to the desired setting.
4. Press MODE to save and exit to the settings menu.
5. Press and hold the MODE button to exit the settings menu.



#### **BACKLIGHT COLOR**

The information center backlight can be set to either blue or red.

1. Press and hold the MODE button to enter the settings menu.
2. Press either toggle button to cycle to the "BL COLOR" option. Press MODE to select.
3. Press either toggle button to cycle to the desired setting.
4. Press MODE to save and exit to the settings menu,



### **BACKLIGHT BRIGHTNESS**

The information center backlight can be set to either blue or red.

1. Press and hold the MODE button to enter the settings menu.
2. Press either toggle button to cycle to the "BL LEVEL" option. Press MODE to select.
3. Press "UP" button to increase brightness. Press "DOWN" button to decrease brightness.
4. Press MODE to select and exit to the settings menu.



### **CLOCK**

The clock must be reset any time the battery has been disconnected or discharged.

1. Press and hold the MODE button to enter the settings menu.
2. Press either toggle button to cycle to the "CLOCK" option. Press MODE to select.
3. Press either toggle button to cycle to the desired setting (12H or 24H). Press MODE to select.
4. Press either toggle button to change each segment of the clock. Press MODE to accept a change and advance to the next segment.



## FEATURES AND CONTROLS

### DISPLAY UNITS (STANDARD/METRIC)



1. Press and hold the MODE button to enter the settings menu.
2. Press either toggle button to cycle to the desired “UNITS” option (distance, temperature or volume). Press MODE to select.
3. Press either toggle button to cycle to the desired setting.
4. Press MODE to save and exit to the settings menu.

### TRIP METER

Use a trip meter to track the distance traveled during a specific trip or period of time. Reset the meter to zero before traveling.

1. Press either toggle button to cycle to the desired trip meter option (T1 or T2).
2. Press and hold either toggle button until the meter resets to zero.



### TRIP TIME

Use a trip time meter to track the travel time during a specific trip. Reset the meter to zero before traveling.

1. Press either toggle button to cycle to the trip time option (TT).
2. Press and hold either toggle button until the meter resets to zero.



### **PROGRAMMABLE SERVICE INTERVAL**

The service interval counter is programmed to 25 hours at the factory. As hours of engine operation increase, the counter decreases. The wrench icon will flash for about 10 seconds when the counter reaches zero (0), and each time the key is turned on thereafter, until the counter is reset.

When this feature is enabled, it provides a convenient reminder to perform routine maintenance. Refer to the Periodic Maintenance Chart for recommended service intervals.

Use the following procedure to reset or change the service interval.

1. Press and hold the MODE button to enter the settings menu.
2. Press either toggle button to cycle to the "Service Hours" option. Press MODE to select.
3. Press MODE to reset the existing value and exit, or press either toggle button to change the value. Press MODE to save and exit to the settings menu.



## FEATURES AND CONTROLS

### ENGINE ERROR CODES

The error screen displays only when the CHECK ENGINE indicator is on or when it goes on and off during one ignition cycle. Error codes are not stored. When the key is turned OFF, the code and message is lost, but will reappear if the fault reoccurs after restarting the engine.

If the CHECK ENGINE lamp or the EPS lamp illuminates, retrieve the active error codes from the display.

- ① Failure Mode Indicator (FMI)
- ② Suspect Parameter Number (SPN)
- ③ Code Count

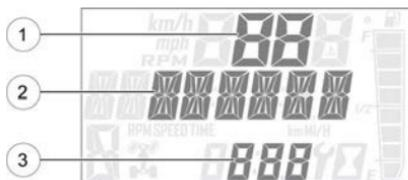

1. Press and hold the MODE button to enter the settings menu.
2. Press either toggle button to cycle to the "DIAGCODE" option. Press MODE to select.
3. More than one diagnostic code may be present. Press the toggle UP button to see if more codes are present. Press MODE to select a code.

#### NOTICE

If the displayed code is an engine fault code, the CHECK ENGINE lamp will blink. If the displayed code is an EPS fault code, the EPS lamp will blink.

4. Record the three (3) numbers displayed.
5. Press MODE to exit to the settings menu.

## DIAGNOSTIC DISPLAY CODE DEFINITIONS

**Open Load:** There is a break in the wires that lead to the item listed in the chart (injector, fuel pump, etc.), or the item has failed.

**Short-to-Ground:** The wire is shorted to ground between the electronic control unit and the item listed in the chart.

**Shorted Load:** The wires leading to the item listed in the chart are shorted together, or the item has shorted internally.

**Short-to-Battery:** The wire leading from the item listed in the chart to the electronic control unit is shorted to a wire at battery voltage.

<b>DIAGNOSTIC CODES</b>			
<b>COMPONENT</b>	<b>CONDITION</b>	<b>SPN</b>	<b>FMI</b>
<b>Engine Control Module</b>			
Accelerator Position 2	Data Erratic, Intermittent Or Incorrect	29	2
	Voltage Above Normal, Or Shorted To High Source	29	3
	Voltage Below Normal, Or Shorted To Low Source	29	4
Throttle Position Sensor 1	Data Valid But Above Normal Operational Range - Most Severe Level	51	0
	Data Valid But Below Normal Operational Range - Most Severe Level	51	1
	Data Erratic, Intermittent Or Incorrect	51	2
	Voltage Above Normal, Or Shorted To High Source	51	3
	Voltage Below Normal, Or Shorted To Low Source	51	4
	Abnormal Rate Of Change	51	10
	Out Of Calibration	51	13

## FEATURES AND CONTROLS

DIAGNOSTIC CODES			
COMPONENT	CONDITION	SPN	FMI
Vehicle Speed Sensor	Data Valid But Above Normal Operational Range - Most Severe Level	84	0
	Data Valid But Below Normal Operational Range - Most Severe Level	84	1
	Data Erratic, Intermittent Or Incorrect	84	2
	Voltage Above Normal, Or Shorted To High Source	84	3
	Voltage Below Normal, Or Shorted To Low Source	84	4
	Abnormal Frequency Or Pulse Width Or Period	84	8
	Abnormal Update Rate	84	9
	Abnormal Rate Of Change	84	10
	Bad Intelligent Device Or Component	84	12
	Received Network Data In Error	84	19
Accelerator Position 1	Data Erratic, Intermittent Or Incorrect	91	2
	Voltage Above Normal, Or Shorted To High Source	91	3
	Voltage Below Normal, Or Shorted To Low Source	91	4

## FEATURES AND CONTROLS

<b>DIAGNOSTIC CODES</b>			
<b>COMPONENT</b>	<b>CONDITION</b>	<b>SPN</b>	<b>FMI</b>
Manifold Absolute Pressure Sensor	Data Erratic, Intermittent Or Incorrect	102	2
	Voltage Above Normal, Or Shorted To High Source	102	3
	Voltage Below Normal, Or Shorted To Low Source	102	4
	Mechanical System Not Responding Or Out Of Adjustment	102	7
	Abnormal Rate Of Change	102	10
Intake Air Temperature Sensor	Data Erratic, Intermittent Or Incorrect	105	2
	Voltage Above Normal, Or Shorted To High Source	105	3
	Voltage Below Normal, Or Shorted To Low Source	105	4
	Abnormal Rate Of Change	105	10
	Data Valid But Above Normal Operating Range - Least Severe Level	105	15

## FEATURES AND CONTROLS

DIAGNOSTIC CODES			
COMPONENT	CONDITION	SPN	FMI
Engine Temperature Sensor	Data Valid But Above Normal Operational Range - Most Severe Level	110	0
	Data Erratic, Intermittent Or Incorrect	110	2
	Voltage Above Normal, Or Shorted To High Source	110	3
	Voltage Below Normal, Or Shorted To Low Source	110	4
	Abnormal Rate Of Change	110	10
	Data Valid But Above Normal Operating Range - Least Severe Level	110	15
	Data Valid But Above Normal Operating Range - Moderately Severe Level	110	16
	Data Valid But Below Normal Operating Range - Least Severe Level	110	17

## FEATURES AND CONTROLS

<b>DIAGNOSTIC CODES</b>			
<b>COMPONENT</b>	<b>CONDITION</b>	<b>SPN</b>	<b>FMI</b>
System Power	Data Valid But Above Normal Operational Range - Most Severe Level	168	0
	Data Valid But Below Normal Operational Range - Most Severe Level	168	1
	Voltage Above Normal, Or Shorted To High Source	168	3
	Voltage Below Normal, Or Shorted To Low Source	168	4
	Data Valid But Above Normal Operating Range - Moderately Severe Level	168	16
	Data Valid But Below Normal Operating Range - Moderately Severe Level	168	18
Engine Speed	Data Valid But Above Normal Operational Range - Most Severe Level	190	0
	Data Valid But Below Normal Operational Range - Most Severe Level	190	1
	Data Erratic, Intermittent Or Incorrect	190	2
	Mechanical System Not Responding Or Out Of Adjustment	190	7
	Received Network Data In Error	190	19
	Condition Exists	190	31

## FEATURES AND CONTROLS

DIAGNOSTIC CODES			
COMPONENT	CONDITION	SPN	FMI
Gear Sensor Signal	Data Erratic, Intermittent Or Incorrect	523	2
	Voltage Above Normal, Or Shorted To High Source	523	3
	Voltage Below Normal, Or Shorted To Low Source	523	4
	Abnormal Update Rate	523	9
ECU Memory	Bad Intelligent Device Or Component	628	12
	Out Of Calibration	628	13
Calibration	Out Of Calibration	630	13
Crankshaft Position Sensor	Data Erratic, Intermittent Or Incorrect	636	2
	Abnormal Frequency Or Pulse Width Or Period	636	8
Injector 1 (Front) (MAG) (SDI Port Injector)	Voltage Above Normal, Or Shorted To High Source	651	3
	Voltage Below Normal, Or Shorted To Low Source	651	4
	Current Below Normal Or Open Circuit	651	5
Fan Relay Driver Circuit	Voltage Above Normal, Or Shorted To High Source	1071	3
	Voltage Below Normal, Or Shorted To Low Source	1071	4
	Current Below Normal Or Open Circuit	1071	5

## FEATURES AND CONTROLS

<b>DIAGNOSTIC CODES</b>			
<b>COMPONENT</b>	<b>CONDITION</b>	<b>SPN</b>	<b>FMI</b>
Ignition Coil Primary Driver 1 (Front) (MAG)	Voltage Above Normal, Or Shorted To High Source	1268	3
	Voltage Below Normal, Or Shorted To Low Source	1268	4
	Current Below Normal Or Open Circuit	1268	5
Fuel Pump Driver Circuit	Voltage Above Normal, Or Shorted To High Source	1347	3
	Voltage Below Normal, Or Shorted To Low Source	1347	4
	Current Below Normal Or Open Circuit	1347	5
Oxygen Sensor 1	Data Erratic, Intermittent Or Incorrect	3056	2
	Voltage Above Normal, Or Shorted To High Source	3056	3
	Voltage Below Normal, Or Shorted To Low Source	3056	4
	Bad Intelligent Device Or Component	3056	12

## FEATURES AND CONTROLS

<b>DIAGNOSTIC CODES</b>			
<b>COMPONENT</b>	<b>CONDITION</b>	<b>SPN</b>	<b>FMI</b>
ECU Output Supply Voltage 1	Data Valid But Above Normal Operational Range - Most Severe Level	3597	0
	Data Valid But Below Normal Operational Range - Most Severe Level	3597	1
	Voltage Above Normal, Or Shorted To High Source	3597	3
	Voltage Below Normal, Or Shorted To Low Source	3597	4
	Data Valid But Above Normal Operating Range - Moderately Severe Level	3597	16
	Data Valid But Below Normal Operating Range - Moderately Severe Level	3597	18

## FEATURES AND CONTROLS

<b>DIAGNOSTIC CODES</b>			
<b>COMPONENT</b>	<b>CONDITION</b>	<b>SPN</b>	<b>FMI</b>
ECU Output Supply Voltage 2	Data Valid But Above Normal Operational Range - Most Severe Level	3598	0
	Data Valid But Below Normal Operational Range - Most Severe Level	3598	1
	Voltage Above Normal, Or Shorted To High Source	3598	3
	Voltage Below Normal, Or Shorted To Low Source	3598	4
	Data Valid But Above Normal Operating Range - Moderately Severe Level	3598	16
	Data Valid But Below Normal Operating Range - Moderately Severe Level	3598	18
ECU Output Supply Voltage 3	Data Valid But Above Normal Operational Range - Most Severe Level	3599	0
	Data Valid But Below Normal Operational Range - Most Severe Level	3599	1
	Voltage Above Normal, Or Shorted To High Source	3599	3
	Voltage Below Normal, Or Shorted To Low Source	3599	4
	Data Valid But Above Normal Operating Range - Moderately Severe Level	3599	16
	Data Valid But Below Normal Operating Range - Moderately Severe Level	3599	18

## FEATURES AND CONTROLS

<b>DIAGNOSTIC CODES</b>			
<b>COMPONENT</b>	<b>CONDITION</b>	<b>SPN</b>	<b>FMI</b>
ETC Accelerator Position Sensor Outputs 1 & 2 Correlation	Data Erratic, Intermittent Or Incorrect	65613	2
Throttle Position Sensor 2	Data Valid But Above Normal Operational Range - Most Severe Level	520198	0
	Data Valid But Below Normal Operational Range - Most Severe Level	520198	1
	Data Erratic, Intermittent Or Incorrect	520198	2
	Voltage Above Normal, Or Shorted To High Source	520198	3
	Voltage Below Normal, Or Shorted To Low Source	520198	4
	Abnormal Rate Of Change	520198	10
	Out Of Calibration	520198	13
Fuel Correction Front	Data Valid But Above Normal Operating Range - Least Severe Level	520204	15
	Data Valid But Below Normal Operating Range - Least Severe Level	520204	17
All Wheel Drive Control Circuit	Voltage Above Normal, Or Shorted To High Source	520207	3
	Voltage Below Normal, Or Shorted To Low Source	520207	4
	Current Below Normal Or Open Circuit	520207	5

## FEATURES AND CONTROLS

<b>DIAGNOSTIC CODES</b>			
<b>COMPONENT</b>	<b>CONDITION</b>	<b>SPN</b>	<b>FMI</b>
Oxygen Sensor Heater 1	Data Erratic, Intermittent Or Incorrect	520209	2
	Voltage Above Normal, Or Shorted To High Source	520209	3
	Voltage Below Normal, Or Shorted To Low Source	520209	4
	Current Below Normal Or Open Circuit	520209	5
Accelerator Position/Brake Position Interaction	Condition Exists	520275	31
Throttle Position Sensor (1 or 2 Indeterminable)	Data Erratic, Intermittent Or Incorrect	520276	2
	Bad Intelligent Device Or Component	520276	12
Throttle Body Control - Power Stage	Data Erratic, Intermittent Or Incorrect	520277	2
	Voltage Above Normal, Or Shorted To High Source	520277	3
	Voltage Below Normal, Or Shorted To Low Source	520277	4
	Abnormal Frequency Or Pulse Width Or Period	520277	8
	Condition Exists	520277	31
Throttle Body Control - Return Spring Check Failed	Condition Exists	520278	31
Throttle Body Control - Adaption Aborted	Condition Exists	520279	31

## FEATURES AND CONTROLS

DIAGNOSTIC CODES			
COMPONENT	CONDITION	SPN	FMI
Throttle Body Control - Limp Home Position Check Failed	Condition Exists	520280	31
Throttle Body Control - Mechanical Stop Adaptation Failure	Condition Exists	520281	31
Throttle Body Control - Repeated Adaptation Failed	Condition Exists	520282	31
Throttle Body Control	Data Erratic, Intermittent Or Incorrect	520283	2
	Voltage Above Normal, Or Shorted To High Source	520283	3
	Voltage Below Normal, Or Shorted To Low Source	520283	4
Throttle Body Control - Position Deviation Fault	Condition Exists	520284	31
ECU Monitoring Error	Condition Exists	520286	31
ECU Monitoring Error (Level 3)	Condition Exists	520287	31
ECU Monitoring of Injection Cut Off (Level 1)	Condition Exists	520288	31
ECU Monitoring of Injection Cut Off (Level 2)	Condition Exists	520289	31
Throttle Body Control - Requested Throttle Angle Not Plausible	Condition Exists	520305	31

## FEATURES AND CONTROLS

<b>DIAGNOSTIC CODES</b>			
<b>COMPONENT</b>	<b>CONDITION</b>	<b>SPN</b>	<b>FMI</b>
ECU ADC Fault - No Load	Condition Exists	520306	31
ECU ADC Fault - Voltage	Condition Exists	520307	31
Accelerator Sensor Sync Fault - Sensor Diff Exceeds Limit	Condition Exists	520308	31
ECU Fault - ICO	Condition Exists	520309	31
ECU Fault - Hardware Disruption	Condition Exists	520311	31
Idle Fuel Correction Bank 1	Data Valid But Above Normal Operating Range - Least Severe	520342	15
	Data Valid But Below Normal Operating Range - Least Severe	520342	17
Adaptive Fuel Correction Bank 1	Data Valid But Above Normal Operating Range - Least Severe	520344	15
	Data Valid But Below Normal Operating Range - Least Severe	520344	17

## FEATURES AND CONTROLS

DIAGNOSTIC CODES			
COMPONENT	CONDITION	SPN	FMI
<b>EPAS Module</b>			
Steering Over Current Shut Down	Current Above Normal Or Grounded Circuit	520221	6
Steering Excessive Current Error	Current Above Normal Or Grounded Circuit	520222	6
Steering Torque Partial Failure	Condition Exists	520223	31
Steering Torque Full Failure	Condition Exists	520224	31
EPAS Inverter Temperature	Data Valid But Above Normal Operational Range - Most Severe	520225	0
	Data Valid But Above Normal Operating Range - Severe		16
EPAS Communications Receive Data Error	Data Erratic, Intermittent Or Incorrect	520226	2
	Condition Exists	520226	31
Position Encoder Error	Root Cause Not Known	520228	11
	Bad Intelligent Device Or Component	520228	12
	Condition Exists	520228	31
EPAS Software Error	Bad Intelligent Device Or Component	520229	12
	Condition Exists	520229	31
EPAS Power Save Condition	Condition Exists	520231	31
EPS SEPIC Voltage Error	Voltage Above Normal, Or Shorted To High Source	524086	3
	Voltage Below Normal, Or Shorted To Low Source	524086	4
Calibration CRC	Checksum/CRC Error	630	13

## FEATURES AND CONTROLS

<b>DIAGNOSTIC CODES</b>			
<b>COMPONENT</b>	<b>CONDITION</b>	<b>SPN</b>	<b>FMI</b>
Steering Torque Full Failure	Torque Sensor Out of Range	520223	31
	Torque Sensor Linearity Error	520224	31
EPS CAN Communications Receive Error	No RX Message for {{cal parameter}} seconds	520226	2
Vehicle Speed	Vehicle Speed Too High	84	0
	Vehicle Speed Implausible		10
	Received Vehicle Speed has Errors		19
Engine Speed	Engine Speed Too High	190	0
	Received Engine Speed has Errors	190	19
Battery Voltage	Too High	168	3
Battery Voltage	Too Low	168	4

## FEATURES AND CONTROLS

<b>DIAGNOSTIC CODES</b>			
<b>COMPONENT</b>	<b>CONDITION</b>	<b>SPN</b>	<b>FMI</b>
Position Encoder Error	Loss of SPI Communication	520228	12
	Encoder Variance Error		31
EPS Software Error	Manufacturing CRC Error	520229	12
	Boot Count Error		31
ICS Communication	Loss of CAN between EPS and Instrument Cluster	520230	31
EPAS Power Save	5 minute time out	520231	31
ECU Memory	EEPROM Communication Error	628	12
	Application CRC Error		13
VGD Low	VGD Low	524086	4
Absolute Position Sensor	Absolute Position Sensor Out of Range	1807	31
	Absolute Position Sensor Not Calibrated	1807	13

## OPERATION

### IMPORTANT INFORMATION

#### WARNING

Failure to operate the vehicle properly can result in a collision, loss of control, accident or rollover, which may result in serious injury or death. Read and understand all safety warnings outlined in the safety section of this owner's manual.

## VEHICLE BREAK-IN PERIOD

The break-in period for your new POLARIS vehicle is the first 25 hours of operation, or the time it takes to use the first two tanks full of gasoline. Clutch and drive belt break-in periods vary depending on operating conditions.

No single action on your part is as important as a proper break-in period. Careful treatment of a new engine and drive components will result in more efficient performance and longer life for these components. Perform the following procedures carefully.

#### NOTICE

Excessive heat build-up during the first three hours of operation will damage close-fitted engine parts and drive components. Do not operate at full throttle or high speeds during the first three hours of use.

Use of any improper oils may cause serious engine damage. POLARIS Premium 4 Synthetic Oil is specifically formulated for your 4-cycle engine

## ENGINE AND DRIVETRAIN BREAK-IN

1. Fill the fuel tank with the recommended fuel. See page 25. Always exercise extreme caution whenever handling gasoline.
2. Check the oil level. See the Oil Check section for details. Add the recommended oil as needed to maintain the oil level in the safe operating range.
3. Complete the New Operator Driving Procedures outlined on page 86.
4. Avoid aggressive use of the brakes.
5. Vary throttle positions. Do not operate at sustained idle.
6. Perform regular checks on fluid levels, controls and areas outlined on the daily pre-ride inspection checklist. See the Pre-Ride Inspection section for details.
7. Carry only light loads.

## OPERATION

---

8. During the break-in period, change both the oil and the filter at 25 hours or one month.
9. Check fluid levels of transmission and all gearcases after the first 25 hours of operation and every 100 hours thereafter.

### BRAKE SYSTEM BREAK-IN

Apply only moderate braking force for the first 50 stops. Aggressive or overly forceful braking when the brake system is new could damage brake pads and rotors.

### PVT BREAK-IN (CLUTCHES / BELT)

A proper break-in of the clutches and drive belt will ensure a longer life and better performance. If a belt fails, always clean any debris from the duct and from the engine compartment.

### STANDARD BREAK-IN

Drive at slower speeds for the first 50 miles (80 km) of operation. Carry only light loads. Avoid aggressive acceleration, high-speed operation and prolonged operation at a specific RPM during this period.

### SAND / DUNE / MUD BREAK-IN

Drive in low gear for the first 5 miles (8 km) of operation. Avoid prolonged low speed operation at high throttle. Avoid aggressive acceleration, high-speed operation and prolonged operation at a specific RPM during this period.

## PRE-RIDE INSPECTION

Failure to inspect and verify that the vehicle is in safe operating condition before operating increases the risk of an accident. Always inspect the vehicle before each use to make sure it's in safe operating condition.

ITEM	REMARKS	REF
Brake system/pedal travel	Ensure proper operation	page 36 page 164
Brake fluid	Ensure proper level	page 166
Front suspension	Inspect, lubricate if necessary	page 139
Rear suspension	Inspect, lubricate if necessary	page 139
Steering	Ensure free operation	page 178
Tires	Inspect condition and pressure	page 16 page 172

ITEM	REMARKS	REF
Wheels/fasteners	Inspect, ensure fastener tightness	page 174
Frame nuts, bolts, fasteners	Inspect, ensure tightness	–
Fuel and oil	Ensure proper levels	page 34 page 142
Coolant level	Ensure proper level	page 154
Coolant hoses	Inspect for leaks	–
Throttle	Ensure proper operation	–
Indicator lights/ switches	Ensure proper operation	page 57
PVT intake pre-filter	Inspect, clean	page 157
Headlights	Check operation	–
Brake light/taillight	Check operation	–
Seat Latches	Push down on both seat backs to ensure the latches are secure	page 33
Seat Belts	Check length of belt for damage, check latches for proper operation	page 41
Cab Doors	Check doors and latches for wear or damage.	page 19
Grass and Leaves	Remove grass, leaves, and other flammable material or debris, especially near the HOT exhaust system.	–

## SAFE OPERATION PRACTICES

1. Visit the Recreational Off-Highway Vehicle Association® web site ([rohva.org](http://rohva.org)) and take the free on-line training course. Complete the steps in the New Operator Driving Procedures section.
2. Do not allow anyone under 16 years of age or without a valid driver's license to operate this vehicle.

## OPERATION

---

3. Never carry a passenger on a 1-seat vehicle. Never carry more than one passenger in a 2-seat vehicle. Never carry more than three passengers in a 4-seat vehicle. Never allow a passenger to ride in the cargo box.
4. Engine exhaust fumes are poisonous. Never start the engine or let it run in an enclosed area.
5. Never operate with accessories not approved by POLARIS for use on this vehicle.
6. Operate this vehicle off-road only. Never operate the vehicle on pavement or on any public street, road or highway, including dirt and gravel roads.
7. Drive in a manner appropriate for your skills and operating conditions. Never operate at excessive speeds. Never attempt wheelies, jumps, or other stunts. Keep both hands on the steering wheel during operation.
8. Never consume alcohol or drugs before or while operating this vehicle.
9. Always use the size and type of tires specified for your vehicle. Always maintain proper tire pressure.
10. Never operate a damaged vehicle. After any rollover or accident, have a qualified service dealer inspect the entire machine for possible damage.
11. Never operate the vehicle on a frozen body of water unless you have first verified that the ice is sufficiently thick to support the weight and moving force of the vehicle, you and any passengers, and your cargo, together with any other vehicles in your party.
12. Do not touch hot exhaust system components. Always keep combustible materials away from the exhaust system.
13. Always remove the ignition key when the vehicle is not in use to prevent unauthorized use.

## STARTING THE ENGINE

### NOTICE

Operating the vehicle immediately after starting could cause engine damage. Allow the engine to warm up for several minutes before operating the vehicle.

1. Position the vehicle on a level surface outdoors or in a well-ventilated area.
2. Sit in the driver's seat and fasten the seat belt. Always make sure all cab doors are closed and latched when riding in this vehicle.
3. Place the transmission in PARK.
4. Apply the brakes. Do not press the throttle pedal while starting the engine.

5. Turn the ignition key past the ON/RUN position to START. Engage the starter for a maximum of five seconds. Release the key when the engine starts.
6. If the engine does not start within five seconds, return the ignition switch to the OFF position and wait five seconds. Repeat steps 5 and 6 until the engine starts.
7. After starting the engine, wait 10 seconds before applying throttle.

## STOPPING THE ENGINE

### WARNING

A rolling vehicle can cause serious injury. Always place the transmission in PARK and engage the park brake (if equipped) when stopping the engine.

1. Release the throttle pedal completely and brake to a complete stop.
2. Place the transmission in PARK.
3. Turn the engine off.
4. Slowly release the brake pedal and make sure the transmission is in PARK before exiting the vehicle.
5. Engage the park brake (if equipped).

## BRAKING

1. Release the throttle pedal completely.

### TIP

When the throttle pedal is released completely and engine speed slows to near idle, the vehicle has no engine braking.

2. Press on the brake pedal evenly and firmly.
3. Practice starting and stopping (using the brakes) until you're familiar with the controls.

## PARKING THE VEHICLE

1. Stop the vehicle on a level surface. When parking inside a garage or other structure, be sure that the structure is well ventilated and that the vehicle is not close to any source of flame or sparks, including any appliance with pilot lights.
2. Place the transmission in PARK.
3. Stop the engine.

## OPERATION

---

4. Slowly release the brake pedal and make sure the transmission is in PARK before exiting the vehicle.
5. Engage the park brake (if equipped).
6. Remove the ignition key to prevent unauthorized use.

## KNOW YOUR RIDING AREA / TREAD LIGHTLY®

Familiarize yourself with all laws and regulations concerning the operation of this vehicle in your area. Respect the environment in which you ride your vehicle. Find out where the designated riding areas are by contacting your POLARIS dealer, a local riding club, or local officials.

Help keep our trails open for recreational vehicle use. As an off-road enthusiast, you represent the sport and can set a good example (or a poor example) for others to follow. Tread lightly®. Operate with respect for the terrain, avoid littering, and always stay on the designated trails.

## TRAIL ETIQUETTE

Always practice good etiquette when riding. Allow a safe distance between your vehicle and other vehicles operating in the same area. Communicate to oncoming operators by signaling the number of vehicles in your group. When stopping, move your vehicle to the edge of the trail as far as possible to allow others to pass safely.

## NEW OPERATOR DRIVING PROCEDURES

1. Read and understand the owner's manual and all warning and instruction labels before operating this vehicle.
2. Visit the Recreational Off-Highway Vehicle Association® web site ([rohva.org](http://rohva.org)) and take the free on-line training course. Hands-on training is also available through ROHVA®.
3. Perform the pre-ride inspection.
4. Do not carry a passenger until you have at least two hours of driving experience with this vehicle.
5. Do not carry cargo during this period.
6. Select an open area that allows room to familiarize yourself with vehicle operation and handling.
7. The driver and all passengers must wear helmet, eye protection, gloves, long-sleeve shirt, long pants, over-the-ankle boots and seat belt at all times.
8. Always make sure all cab doors are closed and latched when riding in this vehicle.
9. Sit in the driver's seat and fasten the seat belt.

10. Place the transmission in PARK.
11. Start the engine.
12. Apply the brakes and shift into low gear.
13. Check your surroundings and determine your path of travel.
14. Keeping both hands on the steering wheel, slowly release the brakes and depress the throttle with your right foot to begin driving.
15. Drive slowly at first. On level surfaces, practice starting, stopping, turning, maneuvering, using the throttle and brakes and driving in reverse. Learn how the vehicle handles when making both left and right turns at a slow speed.
16. Increase speed only after mastering all maneuvers at a slow speed.
17. After you become skilled at making turns and begin to operate at faster speeds, follow these precautions:
  - Avoid sharp turns.
  - Never turn while applying heavy throttle.
  - Never make abrupt steering maneuvers.
  - Operate at speeds appropriate for your skills, the conditions and the terrain.
  - DO NOT do power slides, "donuts", jumps or other driving stunts.

## DRIVING WITH PASSENGERS



1. Complete the New Operator Driving Procedures outlined on page 86.
2. Perform the pre-ride inspection. See the Pre-Ride Inspection section for details.
3. Do not carry more than one passenger in a 2-seat vehicle. Do not carry more than three passengers in a 4-seat vehicle. Additional passengers can affect the operator's ability to steer and operate the controls.
4. All riders must be able to sit with backs against the seat, both feet flat on the floor and both hands on the steering wheel (if driving) or on a passenger hand hold.

## OPERATION

---

5. The driver and all passengers must wear helmet, eye protection, gloves, long-sleeve shirt, long pants, over-the-ankle boots and seat belt at all times. See the Safe Riding Gear section for details.
6. Always make sure all cab doors are closed and latched when riding in this vehicle.
7. Allow a passenger to ride only in a passenger seat.
8. Slow down. Always travel at a speed appropriate for your skills, your passengers' skills and operating conditions. Avoid unexpected or aggressive maneuvers that could cause discomfort or injury to a passenger.
9. Vehicle handling may change with passengers and/or cargo on board. Allow more time and distance for braking.
10. Always follow all operating guidelines as outlined on safety labels and in this manual.

## DRIVING UPHILL

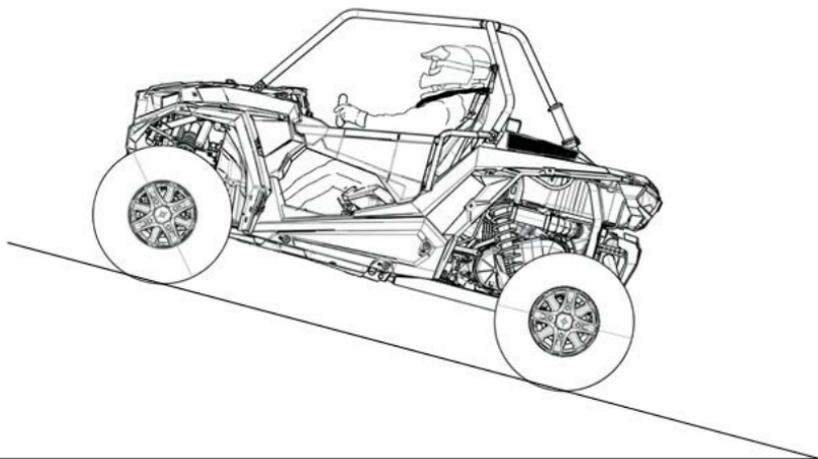

Whenever traveling uphill, follow these precautions:

1. Always check the terrain carefully before ascending a hill. Never drive on hills with excessively slippery or loose surfaces.
2. Avoid excessively steep hills. If ascending a steeper grade is unavoidable, engage all-wheel drive before ascending.
3. Drive straight uphill.

4. Proceed at a steady rate of speed and throttle opening. Never open the throttle suddenly.
5. Avoid unnecessary changes in speed or direction.
6. Never go over the crest of a hill at high speed. An obstacle, a sharp drop, or another vehicle or person could be on the other side of the hill.
7. If the vehicle stalls while climbing a hill, apply the brakes. Place the transmission in reverse and slowly allow the vehicle to roll straight downhill while applying light brake pressure to control speed.

### **DRIVING ON A SIDEHILL (SIDEHILLING)**

Driving on a sidehill is not recommended. Improper procedure could cause loss of control or rollover. Avoid crossing the side of any hill unless absolutely necessary.

If crossing a hill is *unavoidable*, follow these precautions:

1. Engage all-wheel drive.
2. Never operate in TURF mode (if equipped) while operating on a hill or other irregular terrain. Always move the AWD switch to AWD before ascending or descending a hill.
3. Drive slowly and use extreme caution.
4. If the vehicle begins to roll over, or if it feels as if it may roll over, *immediately* turn downhill.
5. Avoid obstacles and changes in terrain that may lower or raise one side of the vehicle or cause the vehicle to slide.
6. If the vehicle begins to slide downhill, immediately turn downhill to stop the slide, or stop the vehicle and maneuver slowly and carefully until the vehicle can be driven straight downhill.

### DRIVING DOWNHILL

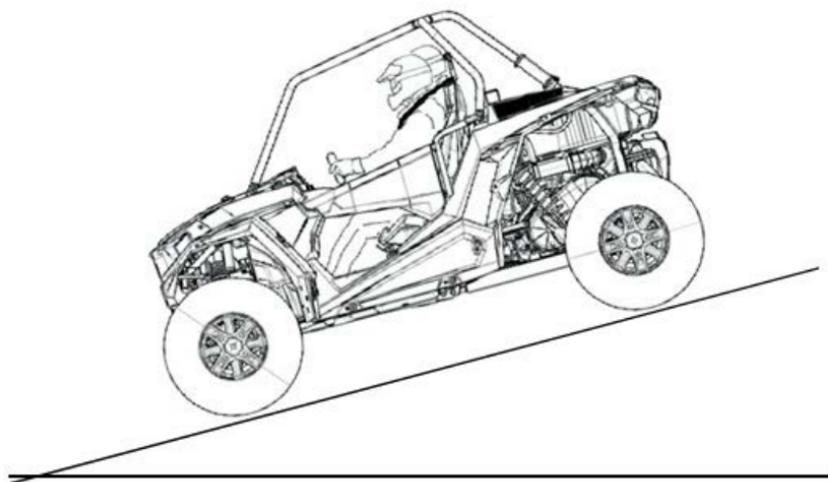

Whenever descending a hill, follow these precautions:

1. Avoid excessively steep hills.
2. Slow down. Never travel down a hill at high speed.
3. Always check the terrain carefully before descending a hill. Never drive on hills with excessively slippery or loose surfaces.
4. Always descend a hill with the transmission in forward gear. *Never descend a hill with the transmission in neutral.*
5. Avoid traveling down a hill at an angle, which would cause the vehicle to lean sharply to one side. Travel straight downhill.
6. Apply the brakes *lightly* to aid in slowing.

## DRIVING THROUGH WATER

Your vehicle can operate through water with a maximum recommended depth equal to floor level. Follow these precautions when operating through water:

1. Determine the water depth and current before entering the water.
2. Choose a crossing where the water level is lowest and where both banks have gradual inclines. Never operate in water that exceeds the maximum recommended depth (floor level) ①.



### WARNING

The large tires on your vehicle may cause the vehicle to float in deep or fast-flowing water, which could result in loss of traction, loss of control, rollover or accident.

3. Wet brakes may have reduced stopping ability. After leaving water, test the brakes. Apply them lightly several times while driving slowly. The friction will help dry out the pads. Avoid applying brake and throttle at the same time.

### NOTICE

Major engine damage can result if the vehicle is not thoroughly inspected after operation in water. Perform the services outlined in the maintenance chart section. Give special attention to engine oil, transmission oil, demand drive fluid, rear gearcase oil, and all grease fittings.

If your vehicle becomes immersed or is operated in water that exceeds the floor level, *service is required before starting the engine*. Your POLARIS dealer or qualified person can provide this service. If it's impossible to bring the vehicle in before starting the engine, perform the service outlined in the Vehicle Immersion section, and take the vehicle in for service at the first opportunity.

### DRIVING ON SLIPPERY SURFACES

When driving on slippery surfaces such as wet trails, loose gravel, or ice, be alert for the possibility of skidding and sliding.

Follow these precautions when encountering slippery conditions:

1. Slow down before entering slippery areas.
2. Maintain a high level of alertness, reading the trail and avoiding quick, sharp turns, which can cause skids.
3. Engage all-wheel drive before wheels begin to lose traction.

#### NOTICE

Severe damage to the drive train may occur if the AWD is engaged while the wheels are spinning. Always allow the wheels to stop spinning before engaging AWD.

4. Correct a skid by turning the steering wheel in the direction of the skid. *Never apply the brakes during a skid.*

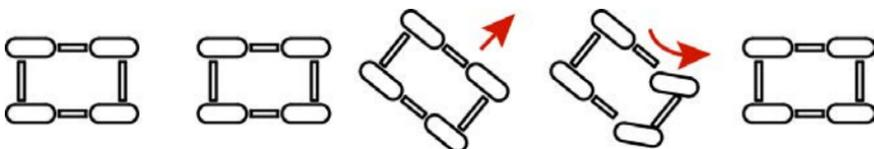

---

## DRIVING OVER OBSTACLES

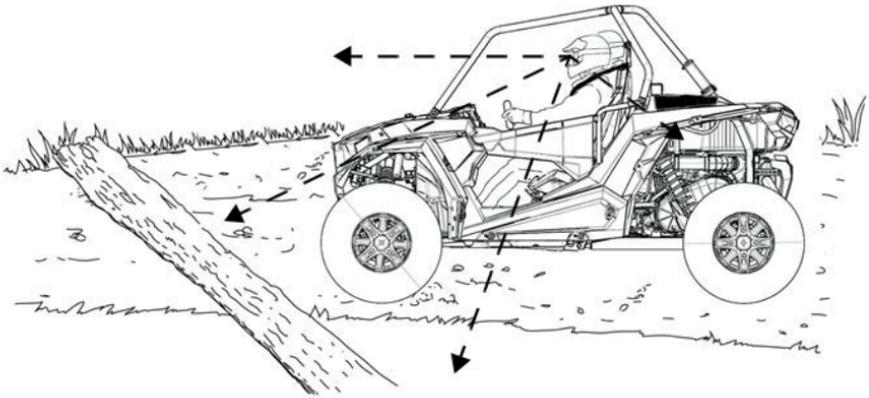

Follow these precautions when operating over obstacles:

1. Always check for obstacles before operating in a new area.
2. Look ahead and learn to read the terrain. Be constantly alert for hazards such as logs, rocks and low hanging branches.
3. Travel slowly and use extra caution when operating on unfamiliar terrain. Not all obstacles are immediately visible.
4. Avoid operating over large obstacles such as large rocks and fallen trees. If unavoidable, use extreme caution and operate slowly.
5. Always have any passengers dismount and move away from the vehicle before operating over an obstacle that could cause a rollover.

### DRIVING IN REVERSE

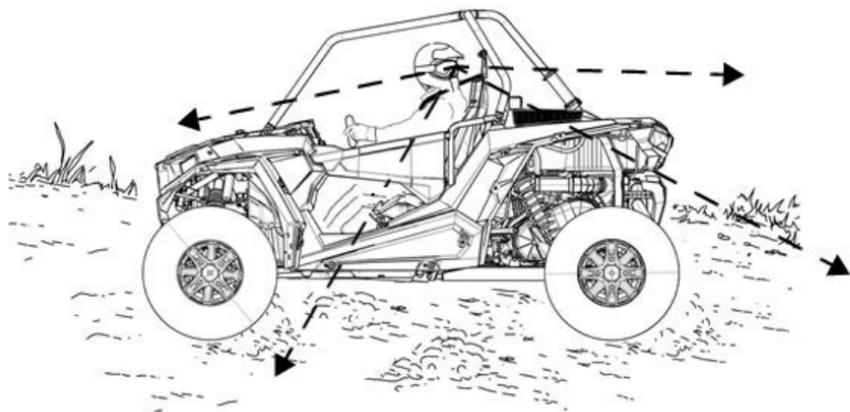

Follow these precautions when operating in reverse:

1. Always check for obstacles or people behind the vehicle.
2. Apply the throttle *lightly*. Never open the throttle suddenly.
3. Back slowly.
4. Apply the brakes *lightly* for stopping.
5. Avoid making sharp turns.

---

## PARKING ON AN INCLINE

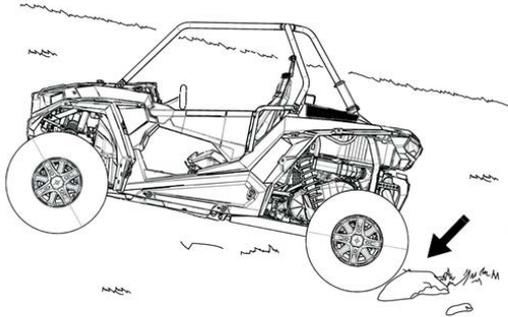

A rolling vehicle can result in serious injury. Avoid parking on an incline. If parking on an incline is *unavoidable*, follow these precautions:

1. Apply the brakes.
2. Place the transmission in PARK.
3. Stop the engine.
4. Slowly release the brake pedal and make sure the transmission is in PARK before exiting the vehicle.
5. Block the rear wheels on the downhill side.

### HAULING CARGO

 **WARNING**

Overloading the vehicle or carrying cargo improperly can alter vehicle handling and may cause loss of control or brake instability. Always follow these precautions when hauling cargo:

Never exceed the stated load capacity for this vehicle.

**REDUCE SPEED AND ALLOW GREATER DISTANCES FOR BRAKING  
WHEN HAULING CARGO.**

**NEVER EXCEED THE MAXIMUM WEIGHT CAPACITY** of the vehicle. When determining the weight you are adding to the vehicle, include the weight of the operator, passengers, accessories and loads in the rack or box. The combined weight of these items must not exceed the maximum weight capacity.

Always load the cargo box with the load as far forward and as low as possible.

When operating over rough or hilly terrain, reduce speed and cargo to maintain stable driving conditions.

Always operate the vehicle with extreme care when hauling cargo. Slow down and drive in the lowest gear available.

**⚠ WARNING**

**SECURE ALL LOADS BEFORE OPERATING.** Unsecured loads can create unstable operating conditions, which could result in loss of control of the vehicle.

**OPERATE ONLY WITH STABLE AND SAFELY ARRANGED LOADS.** When handling off-centered loads that cannot be centered, securely fasten the load and operate with extra caution.

**HEAVY LOADS CAN CAUSE BRAKING AND CONTROL PROBLEMS.** Use extreme caution when applying brakes with a loaded vehicle. Avoid terrain or situations that may require backing downhill.

**USE EXTREME CAUTION** when operating with loads that extend over the rack sides. Stability and maneuverability may be adversely affected, causing a rollover.

**DO NOT TRAVEL FASTER THAN THE RECOMMENDED SPEEDS.** Vehicle should never exceed 10 mph (16 km/h) while cornering or while ascending or descending a hill.

Carrying a passenger in the cargo box could result in a fall from the vehicle or contact with moving components. Never allow a passenger to ride in the cargo box. A passenger must always be seated in a passenger seat with seat belt secured.



Your POLARIS vehicle has been designed to carry a specific capacity. Reduce speed and allow a greater distance for braking when carrying cargo.

Loads should be centered and carried as low as possible in the box. For stability on rough or hilly terrain, reduce both speed and cargo. Exercise caution if the cargo load extends over the side of the box.

## OPERATION

---

Always read and understand the load distribution warnings listed on warning labels and in this manual. Never exceed the maximum capacities specified for your vehicle. See the Load / Passenger / Tire Warning section for details.

### **BELT LIFE**

To extend belt life, use low gear in the following conditions:

- when hauling or towing heavy cargo.
- when consistently operating at speeds less than 35 mph (56 km/h) in hard-pulling terrain, such as mud, rocks or sand/dune environments.

## TOWING A RZR

Towing this vehicle is not recommended. Always transport the vehicle on a trailer or flatbed with all four wheels off the ground. See the Transporting the Vehicle section for details.

If towing a disabled vehicle is unavoidable, place the disabled vehicle's transmission in neutral. Tow the shortest distance possible. Do not operate faster than 10 mph (16 km/h).

## TOWING LOADS



### WARNING

Towing improperly can alter vehicle handling and may cause loss of control or brake instability.

Always follow these precautions when towing:

1. Never load more than 150 lb (68.1 kg) tongue weight on the towing bracket.
2. When transporting heavy loads and/or when towing, always operate the vehicle in low gear.
3. Do not operate the vehicle faster than 10 mph (16 km/h) when towing. See the Hauling Cargo section. Towing a trailer increases braking distance.
4. Do not tow more than the recommended weight for the vehicle. See the Specifications chapter for this vehicle's maximum weight capacity.
5. Attach a trailer to the trailer hitch bracket only. Do not attach a trailer to any other location or you may lose control of the vehicle.
6. Never tow a trailer on a grade steeper than 15°.

TOTAL TOWED LOAD WEIGHT (LEVEL GROUND)	TOTAL TOWED LOAD WEIGHT (15° GRADE)	TOTAL HITCH VERTICAL WEIGHT	MAXIMUM TOWING SPEED
1,500 lb (681 kg)	850 lb (386 kg)	150 lb (68.1 kg)	10 mph (16 km/h)



---

## WINCH GUIDE

### WINCH SAFETY

These safety warnings and instructions apply if your vehicle came equipped with a winch or if you choose to add an accessory winch to your vehicle.

 **WARNING**

Improper winch use can result in **SEVERE INJURY** or **DEATH**. Always follow all winch instructions and warnings in this manual.

Your winch may have a cable made of either wire rope or specially designed synthetic rope. The term “winch cable” will be used for either unless noted otherwise.

### WINCH SAFETY PRECAUTIONS

1. Read all sections of this manual.
2. Never use alcohol or drugs before or while operating the winch.
3. Never allow children under 16 years of age to operate the winch.
4. Always wear eye protection and heavy gloves when operating the winch.
5. Always keep body, hair, clothing and jewelry clear of the winch cable, fairlead and hook when operating winch.
6. Never attempt to “jerk” a load attached to the winch with a moving vehicle. See the *Shock Loading* section on page 109.
7. Always keep the area around the vehicle, winch, winch cable, and load clear of people (especially children) and distractions while operating the winch.
8. Always turn the vehicle ignition power OFF when it and the winch are not being used.
9. Always be sure that at least five (5) full turns of winch cable are wrapped around the winch drum at all times. The friction provided by this wrapped cable allows the drum to pull on the winch cable and move the load.
10. Always apply your vehicle’s park brake and/or park mechanism to hold the vehicle in place during winching. Use wheel chocks if needed.
11. Always align the vehicle and winch with the load directly in front of the vehicle as much as possible. Avoid winching with the winch cable at an angle to the winching vehicle’s centerline whenever possible.

## WINCH GUIDE

---

12. If winching at an angle is unavoidable, follow these precautions:
  - a. Look at the winch drum occasionally. Never let the winch cable “stack” or accumulate at one end of the winch drum. Too much winch cable at one end of the winch drum can damage the winch and the winch cable.
  - b. If stacking occurs, stop winching. Follow step 15 of Winch Operation to feed and rewind the cable evenly before continuing the winch operation.
13. Never winch up or down at sharp angles. This can destabilize the winching vehicle and possibly cause it to move without warning.
14. Never attempt to winch loads that weigh more than the winch’s rated capacity.
15. The winch motor may become hot during winch use. If you winch for more than 45 seconds, or if the winch stalls during operation, stop winching and permit the winch to cool down for 10 minutes before using it again.
16. Never touch, push, pull or straddle the winch cable while winching a load.
17. Never let the winch cable run through your hands, even if wearing heavy gloves.
18. Never release the clutch on the winch when the winch cable is under load.
19. Never use the winch for lifting or transporting people.
20. Never use the winch to hoist or suspend a vertical load.
21. Always inspect your winch and winch cable before each use.
22. Never winch the hook fully into the winch. This can cause damage to winch components.
23. Unplug the remote control from the vehicle when the winch is not in use to prevent inadvertent activation and use by unauthorized persons.
24. Never grease or oil the winch cable. This will cause the winch cable to collect debris that will shorten the life of the cable.



## WINCH OPERATION

Read the Winch Safety Precautions in the preceding pages before using your winch.

### TIP

Consider practicing the operation and use of your winch before you actually need to use it in the field.

### ⚠ WARNING

Improper winch use can result in **SEVERE INJURY** or **DEATH**. Always follow all winch instructions and warnings in this manual.

Each winching situation is unique.

- Take your time to think through the winching you are about to do.
- Proceed slowly and deliberately.
- Never hurry or rush during winching.
- Always pay attention to your surroundings.
- You may need to change your winching strategy if it is not working.
- Always remember that your winch is very powerful.
- There are simply some situations that you and your winch will not be able to deal with. Do not be afraid to ask others to help when this happens.

1. Always inspect the vehicle, winch, winch cable and winch controls for any signs of damage or parts in need of repair or replacement before each use. *Pay particular attention to the first 3 feet (1 meter) of winch cable if the winch is being used (or has been used) for lifting an accessory plow assembly.* Promptly replace any worn or damaged cable.
2. Never operate a winch or a vehicle in need of repair or service.
3. Always apply your vehicle's park brake and/ or park mechanism to hold the vehicle in place during winching. Use wheel chocks if needed.
4. Always use the hook strap when handling the hook.



## WINCH GUIDE

### WARNING

Never put your fingers into the hook. This could lead to SEVERE INJURY.

- Attach the hook itself onto the load or use a tow strap or chain to secure the load to the winch cable.



### TIP

A “tow strap” is NOT intended to stretch. A “recovery strap” is designed to stretch.

### WARNING

Never use a recovery strap when winching due to the excessive energy that can be released if the winch cable breaks. This can result in SEVERE INJURY or DEATH. See the *Shock Loading* section on page 109.

- Never hook the winch cable back onto itself. This will damage the winch cable and may result in winch cable failure.

### WARNING

Replace the winch cable at the first sign of damage to prevent SEVERE INJURY or DEATH in the event of failure. For your safety, always replace POLARIS winch parts (including the cable) with genuine POLARIS replacement parts available at your authorized POLARIS dealer, or other qualified dealer.

- If possible, keep the winch cable aligned with the centerline of the winching vehicle. This will help the spooling of the winch cable and reduce the load on the fairlead.
- If freeing a stuck vehicle by attaching to a tree, use an item such as a tow strap to avoid damaging the tree during winch operation. Sharp cables and chains can damage and even kill trees. Please remember to TreadLightly® (treadlightly.org).
- Before operating the winch, be sure that the safety latch on the winch cable hook is fully seated when the load is attached.
- Never operate your winch with a damaged hook or latch. Always replace damaged parts before using the winch.

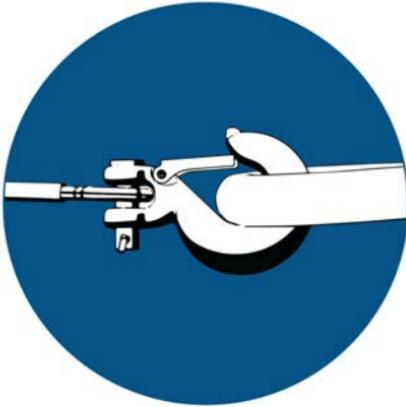

5. Never remove the hook strap from the hook.
6. Release the winch clutch and pull out the winch cable.
7. Pulling out as much cable as possible maximizes the winch's pulling capacity. Always be sure that at least five (5) full turns of winch cable are wrapped around the winch drum at all times. The friction provided by this wrapped cable allows the drum to pull on the winch cable and move the load.
8. Read and adhere to the following information for winch damping to ensure safe winch use.
  - a. In order to absorb energy that could be released by a winch cable failure, always place a "damper" on the winch cable. A damper can be heavy jacket, tarp, or other soft, dense object. A damper can absorb much of the energy released if a winch cable breaks when winching. Even a tree limb can help as a damper if no other items are available to you.
  - b. Lay the damper on top of the mid-point of the winch cable length that is spooled out.

## WINCH GUIDE

---

- c. On a long pull, it may be necessary to stop winching so that the damper can be repositioned to the new mid-point of the winch cable. Always release the tension on the winch cable before repositioning the damper.
  - d. Avoid being directly in line with the winch cable whenever possible. Also, never permit others to stand near or in line with the winch cable during winch operation.
9. Never hook the winch cable back onto itself. This will damage the winch cable and may result in winch cable failure.
10. Never use straps, chains or other rigging items that are damaged or worn.
11. The ONLY time a winch-equipped vehicle should be moving when using the winch is when that vehicle itself is stuck. The winch equipped vehicle should NEVER be in motion to “shock” load the winch cable in an attempt to move a second stuck vehicle. See the Shock Loading section on page 109. For your safety, always follow these guidelines when winching a vehicle free:
- a. Release the winch clutch and spool out the necessary length of winch cable.
  - b. Align the winch cable as close as possible to the winching vehicle's centerline.
  - c. Attach the winch cable hook to the anchor point or the stuck vehicle's frame following instructions in this manual.
  - d. Re-engage the clutch on the winch.
  - e. Slowly winch in the slack in the winch cable.
  - f. Select the proper vehicle gear to propel the stuck vehicle in the direction of winching.
  - g. Shift to the lowest gear available on the stuck vehicle.
  - h. Slowly and carefully apply vehicle throttle and winch together to free the vehicle.
  - i. Stop winching as soon as the stuck vehicle is able to propel itself without the help of the winch.
  - j. Detach the winch cable hook.
  - k. Rewind the winch cable evenly back onto the winch drum following the instructions in this manual.
12. Never attempt to winch another stuck vehicle by attaching the winch cable to a suspension component, brush guard, bumper or cargo rack. Vehicle damage may result. Instead, attach the winch to a strong portion of the vehicle frame or hitch.

13. Extensive winching will run down the battery on the winching vehicle. Let the winching vehicle's engine run while operating the winch to prevent the battery from running low if winching for long periods.
14. The winch motor may become hot during winch use. If you winch for more than 45 seconds, or if the winch stalls during operation, stop winching and permit the winch to cool down for 10 minutes before using it again.
15. After winching is complete, especially if winching at an angle, it may be necessary to re-distribute the winch cable across the winch drum. You will need an assistant to perform this task.
  - a. Release the clutch on the winch.
  - b. Feed out the winch cable that is unevenly bunched up in one area.
  - c. Re-engage the winch clutch.
  - d. Have an assistant pull the winch cable tightly with about 100 lbs. (45 kg) of tension using the hook strap.
  - e. Slowly winch the cable in while your assistant moves the end of the winch cable back and forth horizontally to evenly distribute the winch cable on the drum.
  - f. Doing this reduces the chances of the winch cable "wedging" itself between lower layers of winch cable.

### WINCH CABLE CARE

#### WARNING

Use of worn or damaged cable could lead to sudden failure and SEVERE INJURY.

For your safety, always replace POLARIS winch parts (including the cable) with genuine POLARIS replacement parts available at your authorized POLARIS dealer, or other qualified person.

1. Always inspect your winch before each use. Inspect for worn or loose parts including mounting hardware. Never use the winch if any part needs repair or replacement.
2. Always inspect your winch cable before each use. Inspect for worn or kinked winch cable.

A kinked winch cable made of wire rope is shown at right. Even after being “straightened out,” this cable has already been permanently and severely damaged. Promptly discontinue use of a winch cable in this condition.

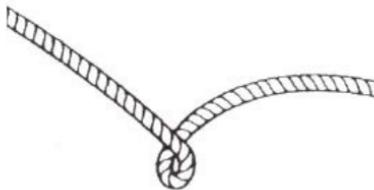

A kinked winch cable made of wire rope that has been “straightened out” is shown at right. Even though it may look usable, the cable has been permanently and severely damaged. It can no longer transmit the load that it could prior to kinking. Promptly discontinue use of a winch cable in this condition.

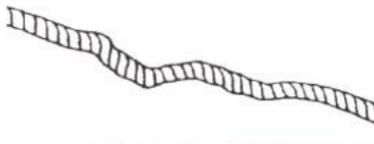

A winch cable made of synthetic rope should be inspected for signs of fraying. Replace the cable if fraying is observed (shown below). Promptly discontinue use of a winch cable in this condition. Also replace the winch cable if there are fused or melted fibers. Such an area of the synthetic rope will be stiff and appear smooth or glazed. Promptly discontinue use of a winch cable in this condition.



---

## SHOCK LOADING

 **WARNING**

Your winch cable is very strong but it is NOT designed for dynamic, or “shock” loading. Shock loading may tension a winch cable beyond its strength and cause the cable to break. The end of a broken winch cable under such high loading can cause SEVERE INJURY or DEATH to you and other bystanders.

*Winch cables are designed to NOT absorb energy. This is true of both wire-rope and synthetic-rope winch cables.*

1. Never attempt to “jerk” a load with the winch. For example, never take up slack in the winch cable by moving the winching vehicle in an attempt to move an object. This is a dangerous practice. It generates high winch cable loads that may exceed the strength of the cable. Even a slowly moving vehicle can create large shock loads in a winch cable.

 **WARNING**

SEVERE INJURY or DEATH can result from a broken winch cable.

2. Never quickly turn the winch ON and OFF repeatedly (“jogging”). This puts extra load on the winch, winch cable, and generates excessive heat from the motor. This is a form of shock loading.
3. Never tow a vehicle or other object with your winch. Towing an object with a winch produces shock loading of the cable even when towing at slow speeds. Towing from a winch also positions the towing force high on the vehicle. This can cause instability of the vehicle and possibly lead to an accident.
4. Never use recovery straps with your winch. Recovery straps are designed to stretch and can store energy. This stored energy in the recovery strap is released if a winch cable fails making the event even more hazardous. Similarly, never use elastic “bungee” cords for winching.
5. Never use the winch to tie down a vehicle to a trailer or other transportation vehicle. This type of use also causes shock loading that can cause damage to the winch, winch cable, or vehicles used.

**Your winch cable is designed and tested to withstand the loads produced by the winch motor when operated from a stationary vehicle. Always remember that the winch and winch cable are NOT designed for shock loading.**

### WINCH MAINTENANCE AND SERVICE SAFETY

 **WARNING**

Improper or lack of winch maintenance and service could lead to **SEVERE INJURY** or **DEATH**. Always follow all winch instructions and warnings in this manual.

1. Always inspect your winch before each use. Inspect for worn or kinked winch cable. Also inspect for worn or loose parts including mounting hardware.
2. Permit your winch motor to cool down prior to servicing your winch.
3. Never work on your winch without first disconnecting the battery connections to prevent accidental activation of the winch.
4. For your safety, always replace POLARIS winch parts (including the cable) with genuine POLARIS replacement parts available at your authorized POLARIS dealer, or other qualified person.
5. Some winch models use wire rope as the winch cable. Other winches use a specially designed synthetic rope as the winch cable.
6. Never replace a synthetic-rope winch cable with a consumer-grade polymer rope such as can be purchased in a hardware store. Although they may look similar, they are **NOT** alike. A polymer rope not designed for winch use will stretch and store excessive energy when winching.

 **WARNING**

Failure of a stretched rope under winching conditions will release all of the stored energy. This will increase the chances of **SEVERE INJURY** or **DEATH**.

# EMISSION CONTROL SYSTEMS

## NOISE EMISSION CONTROL SYSTEM

Do not modify the engine, intake or exhaust components, as doing so may affect compliance with U.S.A. EPA noise control requirements (40 CFR 205) and local noise level requirements.

## OPERATION ON PUBLIC LANDS IN THE U.S.A.

Your POLARIS vehicle has a spark arrester that was tested and qualified to be in accordance with the USFS standard 5100-1C. Federal law requires that this spark arrester be installed and functional when the vehicle is operated on public lands.

Operation of off-road vehicles on public lands in the U.S.A. is regulated by 43 CFR 420. Violations are subject to monetary penalties. Federal regulations can be viewed online at [www.gpoaccess.gov/ecfr/](http://www.gpoaccess.gov/ecfr/).

## CRANKCASE EMISSION CONTROL SYSTEM

This engine is equipped with a closed crankcase system. Blow-by gases are forced back to the combustion chamber by the intake system. All exhaust gases exit through the exhaust system.

## EXHAUST EMISSION CONTROL SYSTEM

Exhaust emissions are controlled by engine design. An electronic fuel injection (EFI) system controls fuel delivery. The engine and EFI components are set at the factory for optimal performance and are not adjustable.

The emissions label is located on the left front frame of the vehicle.

## ELECTROMAGNETIC INTERFERENCE

This spark ignition system complies with Canadian ICES-002.

This vehicle complies with the EMC requirements of European directives 97/24/EC and 2004/108/EC.

**Non-ionizing Radiation:** This vehicle emits some electromagnetic energy. People with active or non-active implantable medical devices (such as heart monitoring or controlling devices) should review the limitations of their device and the applicable electromagnetic standards and directives that apply to this vehicle.



## MAINTENANCE

### PERIODIC MAINTENANCE CHART

Careful periodic maintenance will help keep your vehicle in the safest, most reliable condition. Inspection, adjustment and lubrication of important components are explained in the periodic maintenance chart.

Inspect, clean, lubricate, adjust and replace parts as necessary. When inspection reveals the need for replacement parts, use genuine POLARIS parts available from your POLARIS dealer.

Record maintenance and service in the Maintenance Log at the end of the manual.

Service and adjustments are important for proper vehicle operation. If you're not familiar with safe service and adjustment procedures, have a qualified dealer perform these operations.

Vehicles subjected to heavy or severe use patterns must be inspected and serviced more frequently.

### SEVERE USE DEFINITION

- Frequent immersion in mud, water or sand
- Racing or race-style high RPM use
- Prolonged low speed, heavy load operation
- Extended idle
- Frequent short trip operation in cold weather (engine frequently does not operate long enough to reach full operating temperature)

Pay special attention to the oil level. A rise in oil level during cold weather can indicate contaminants collecting in the oil sump or crankcase. Change oil immediately if the oil level begins to rise. Monitor the oil level, and if it continues to rise, discontinue use and determine the cause or see your authorized dealer.

## MAINTENANCE

---

### MAINTENANCE INTERVALS

The maintenance interval charts outline required maintenance and inspection based on vehicle hours / miles. Each table states the number of hours / miles that service is required on the vehicle. Some items or components may need to be serviced more often due to severe use, such as operation in water or under severe loads. When the vehicle goes beyond 500 hours / 5000 miles (8000 km), return to the 25 hours / 250 miles (400 km) chart and start the interval process over.

#### **25 HOUR / 250 MILES (400 KM) SERVICE**

ITEM		REMARKS
XU / D	Brake Pads / Parking Brake Pads (INT'L)	Inspect pad wear
	Fuel System	Turn key on to pressurize fuel pump; check lines / fittings for leaks and abrasion
XU / D	Parking Brake Cable Adjustment (INT'L)	Inspect; adjust tension after first 25 hours
XU	Engine Breather	Inspect; clean
	Battery	Check terminals; clean; test
XU	Engine Oil & Filter Change (Break-In)	Perform a break-in oil and filter change at 25 hours or one month; perform every 50 hours or 6 months thereafter
XU	Front Gearcase Lubricant	Initial fluid level inspection; add lubricant if needed
XU	Transmission Lubricant (AGL)	Initial fluid level inspection; add lubricant if needed

XU - Perform these procedures more often for vehicles subjected to severe use.

D - Have an authorized Polaris dealer or qualified person perform these services.

**50 HOUR / 500 MILES (800 KM) SERVICE**

ITEM		REMARKS
XU / D	Brake Pads / Parking Brake Pads (INT'L)	Inspect pad wear; replace if worn beyond service limit
	Fuel System	Turn key on to pressurize fuel pump; check lines / fittings for leaks and abrasion
XU / D	Parking Brake Cable Adjustment (INT'L)	Inspect; adjust tension after first 25 hours
XU	Engine Breather	Inspect; clean
	Battery	Check terminals; clean; test
XU	Front Gearcase Lubricant	Inspect / add lubricant if needed
XU	Transmission Lubricant (AGL)	Inspect / add lubricant if needed
XU	General Lubrication	Lubricate all fittings, pivots, cables, etc.
D	Throttle Pedal	Inspect; replace if it sticks
	Throttle Body Intake Ducts/Flange	Inspect ducts for proper sealing / air leaks
	Shift Cable / Linkage	Inspect; adjust as needed
D	Steering	Lubricate (if applicable)
XU	Front / Rear Suspension	Lubricate (if applicable)
D	Cooling System	Inspect coolant strength seasonally; pressure test system yearly
D	Drive Belt	Inspect; replace as needed
D	Clutches (Drive and Driven)	Inspect; clean; replace worn parts
XU	Engine Oil Lines/ Fasteners	Inspect for leaks and loose fittings
XU	Shock Absorbers	Inspect for leaks, loose joints, and wear

XU - Perform these procedures more often for vehicles subjected to severe use.

D - Have an authorized Polaris dealer or qualified person perform these services.

## MAINTENANCE

---

### **75 HOUR / 750 MILES (1200 KM) SERVICE**

ITEM		REMARKS
XU /D	Brake Pads / Parking Brake Pads (INT'L)	Inspect pad wear; replace if worn beyond service limit
	Fuel System	Turn key on to pressurize fuel pump; check lines / fittings for leaks and abrasion
XU /D	Parking Brake Cable Adjustment (INT'L)	Inspect; adjust tension after first 25 hours
XU	Engine Breather	Inspect; clean
	Battery	Check terminals; clean; test
XU	Engine Oil & Filter Change	Change oil and filter, inspect used oil for contaminants
XU	Air Filter	Inspect; replace as needed
XU	Front Gearcase Lubricant	Inspect / add lubricant if needed
XU	Transmission Lubricant (AGL)	Inspect / add lubricant if needed

XU - Perform these procedures more often for vehicles subjected to severe use.

D - Have an authorized Polaris dealer or qualified person perform these services.

**100 HOUR / 1000 MILES (1600 KM) SERVICE**

ITEM		REMARKS
XU / D	Brake Pads / Parking Brake Pads (INT'L)	Inspect pad wear; replace if worn beyond service limit
	Fuel System	Turn key on to pressurize fuel pump; check lines / fittings for leaks and abrasion
XU / D	Parking Brake Cable Adjustment (INT'L)	Inspect; adjust tension after first 25 hours
XU	Engine Breather	Inspect; clean
	Battery	Check terminals; clean; test
XU	General Lubrication	Lubricate all fittings, pivots, cables, etc.
D	Throttle Pedal	Inspect; replace if it sticks
	Throttle Body Intake Ducts/Flange	Inspect ducts for proper sealing / air leaks
	Shift Cable / Linkage	Inspect; adjust as needed
D	Steering	Lubricate (if applicable)
XU	Front / Rear Suspension	Lubricate (if applicable)
D	Cooling System	Inspect coolant strength seasonally; pressure test system yearly
D	Drive Belt	Inspect; replace as needed
XU	Engine Oil Lines/ Fasteners	Inspect for leaks and loose fittings
XU / D	Parking Brake Cable Adjustment (INT'L)	Inspect; adjust tension as needed
XU	Front Gearcase Lubricant	Change lubricant
XU	Transmission Lubricant (AGL)	Change lubricant
D	Fuel System	Check for leaks at fill cap, fuel line / rail, and fuel pump.
D	Spark Plug Inspection	Inspect; replace as needed; torque to specification
XU	Radiator	Inspect; clean external surfaces
XU	Cooling Hoses	Inspect for leaks; pressure test system
XU	Engine Mounts	Inspect, torque to specification
	Exhaust Silencer / Pipe	Inspect

## MAINTENANCE

ITEM		REMARKS
XU	Wiring	Inspect for wear, routing, security; inspect connectors subjected to water, mud, etc.
D	Clutches (Drive and Driven)	Inspect; clean; replace worn parts
D	Front Wheel Bearings	Inspect; replace as needed
	Cam Chain Tensioner	Inspect/clean; replace as needed
XU	Shock Absorbers	Inspect for leaks, loose joints, and wear

XU - Perform these procedures more often for vehicles subjected to severe use.

D - Have an authorized Polaris dealer or qualified person perform these services.

**125 HOUR / 1250 MILES (2000 KM) SERVICE**

ITEM		REMARKS
XU / D	Brake Pads / Parking Brake Pads (INT'L)	Inspect pad wear; replace if worn beyond service limit
	Fuel System	Turn key on to pressurize fuel pump; check lines / fittings for leaks and abrasion
XU / D	Parking Brake Cable Adjustment (INT'L)	Inspect; adjust tension after first 25 hours
XU	Engine Breather	Inspect; clean
	Battery	Check terminals; clean; test
XU	Engine Oil & Filter Change	Change oil and filter, inspect used oil for contaminants
XU	Air Filter	Inspect; replace as needed
XU	Front Gearcase Lubricant	Inspect / add lubricant if needed
XU	Transmission Lubricant (AGL)	Inspect / add lubricant if needed

XU - Perform these procedures more often for vehicles subjected to severe use.

D - Have an authorized Polaris dealer or qualified person perform these services.

## MAINTENANCE

### **150 HOUR / 1500 MILES (2400 KM) SERVICE**

ITEM		REMARKS
XU / D	Brake Pads / Parking Brake Pads (INT'L)	Inspect pad wear; replace if worn beyond service limit
	Fuel System	Turn key on to pressurize fuel pump; check lines / fittings for leaks and abrasion
XU / D	Parking Brake Cable Adjustment (INT'L)	Inspect; adjust tension after first 25 hours
XU	Engine Breather	Inspect; clean
	Battery	Check terminals; clean; test
XU	Front Gearcase Lubricant	Inspect / add lubricant if needed
XU	Transmission Lubricant (AGL)	Inspect / add lubricant if needed
XU	General Lubrication	Lubricate all fittings, pivots, cables, etc.
D	Throttle Pedal	Inspect; replace if it sticks
	Throttle Body Intake Ducts/Flange	Inspect ducts for proper sealing / air leaks
	Shift Cable / Linkage	Inspect; adjust as needed
D	Steering	Lubricate (if applicable)
XU	Front / Rear Suspension	Lubricate (if applicable)
D	Cooling System	Inspect coolant strength seasonally; pressure test system yearly
D	Drive Belt	Inspect; replace as needed
D	Clutches (Drive and Driven)	Inspect; clean; replace worn parts
XU	Engine Oil Lines/ Fasteners	Inspect for leaks and loose fittings
XU	Shock Absorbers	Inspect for leaks, loose joints, and wear

XU - Perform these procedures more often for vehicles subjected to severe use.

D - Have an authorized Polaris dealer or qualified person perform these services.

**175 HOUR / 1750 MILES (2800 KM) SERVICE**

ITEM		REMARKS
XU / D	Brake Pads / Parking Brake Pads (INT'L)	Inspect pad wear; replace if worn beyond service limit
	Fuel System	Turn key on to pressurize fuel pump; check lines / fittings for leaks and abrasion
XU / D	Parking Brake Cable Adjustment (INT'L)	Inspect; adjust tension after first 25 hours
XU	Engine Breather	Inspect; clean
	Battery	Check terminals; clean; test
XU	Engine Oil & Filter Change	Change oil and filter, inspect used oil for contaminants
XU	Air Filter	Inspect; replace as needed
XU	Front Gearcase Lubricant	Inspect / add lubricant if needed
XU	Transmission Lubricant (AGL)	Inspect / add lubricant if needed

XU - Perform these procedures more often for vehicles subjected to severe use.

D - Have an authorized Polaris dealer or qualified person perform these services.

## MAINTENANCE

### **200 HOUR / 2000 MILES (3200 KM) SERVICE**

ITEM		REMARKS
XU / D	Brake Pads / Parking Brake Pads (INT'L)	Inspect pad wear; replace if worn beyond service limit
	Fuel System	Turn key on to pressurize fuel pump; check lines / fittings for leaks and abrasion
XU / D	Parking Brake Cable Adjustment (INT'L)	Inspect; adjust tension after first 25 hours
XU	Engine Breather	Inspect; clean
	Battery	Check terminals; clean; test
XU	General Lubrication	Lubricate all fittings, pivots, cables, etc.
D	Throttle Pedal	Inspect; replace if it sticks
	Throttle Body Intake Ducts/Flange	Inspect ducts for proper sealing / air leaks
	Shift Cable / Linkage	Inspect; adjust as needed
D	Steering	Lubricate (if applicable)
XU	Front / Rear Suspension	Lubricate (if applicable)
D	Cooling System	Inspect coolant strength seasonally; pressure test system yearly
D	Drive Belt	Inspect; replace as needed
D	Clutches (Drive and Driven)	Inspect; clean; replace worn parts
XU	Engine Oil Lines/ Fasteners	Inspect for leaks and loose fittings
XU / D	Parking Brake Cable Adjustment (INT'L)	Inspect; adjust tension as needed
XU	Front Gearcase Lubricant	Change lubricant
XU	Transmission Lubricant (AGL)	Change lubricant
D	Fuel System	Check for leaks at fill cap, fuel line / rail, and fuel pump.
D	Spark Plug Inspection	Inspect; replace as needed; torque to specification
XU	Radiator	Inspect; clean external surfaces
XU	Cooling Hoses	Inspect for leaks; pressure test system
XU	Engine Mounts	Inspect, torque to specification

## MAINTENANCE

ITEM		REMARKS
	Exhaust Silencer / Pipe	Inspect
XU	Wiring	Inspect routing and for wear; inspect connectors subjected to water/mud.
D	Front Wheel Bearings	Inspect; replace as needed
D	Brake Fluid	Change every two years (DOT 4)
	Spark Arrestor	Clean daily if driven in mud / water; replace a damaged arrestor before operating
	Cam Chain Tensioner	Inspect/clean; replace as needed
D	Valve Clearance	Inspect; adjust as needed
XU	Shock Absorbers	Inspect for leaks, loose joints, and wear

XU - Perform these procedures more often for vehicles subjected to severe use.

D - Have an authorized Polaris dealer or qualified person perform these services.

## MAINTENANCE

---

### **225 HOUR / 2250 MILES (3600 KM) SERVICE**

ITEM		REMARKS
XU / D	Brake Pads / Parking Brake Pads (INT'L)	Inspect pad wear; replace if worn beyond service limit
	Fuel System	Turn key on to pressurize fuel pump; check lines / fittings for leaks and abrasion
XU / D	Parking Brake Cable Adjustment (INT'L)	Inspect; adjust tension after first 25 hours
XU	Engine Breather	Inspect; clean
	Battery	Check terminals; clean; test
XU	Engine Oil & Filter Change	Change oil and filter, inspect used oil for contaminants
XU	Air Filter	Inspect; replace as needed
XU	Front Gearcase Lubricant	Inspect / add lubricant if needed
XU	Transmission Lubricant (AGL)	Inspect / add lubricant if needed

XU - Perform these procedures more often for vehicles subjected to severe use.

D - Have an authorized Polaris dealer or qualified person perform these services.

**250 HOUR / 2500 MILES (4000 KM) SERVICE**

ITEM		REMARKS
XU / D	Brake Pads / Parking Brake Pads (INT'L)	Inspect pad wear; replace if worn beyond service limit
	Fuel System	Turn key on to pressurize fuel pump; check lines / fittings for leaks and abrasion
XU / D	Parking Brake Cable Adjustment (INT'L)	Inspect; adjust tension after first 25 hours
XU	Engine Breather	Inspect; clean
	Battery	Check terminals; clean; test
XU	Front Gearcase Lubricant	Inspect / add lubricant if needed
XU	Transmission Lubricant (AGL)	Inspect / add lubricant if needed
XU	General Lubrication	Lubricate all fittings, pivots, cables, etc.
D	Throttle Pedal	Inspect; replace if it sticks
	Throttle Body Intake Ducts/Flange	Inspect ducts for proper sealing / air leaks
	Shift Cable / Linkage	Inspect; adjust as needed
D	Steering	Lubricate (if applicable)
XU	Front / Rear Suspension	Lubricate (if applicable)
D	Cooling System	Inspect coolant strength seasonally; pressure test system yearly
D	Drive Belt	Inspect; replace as needed
D	Clutches (Drive and Driven)	Inspect; clean; replace worn parts
XU	Engine Oil Lines/ Fasteners	Inspect for leaks and loose fittings
XU / D	Shock Absorbers	Replace or rebuild (if applicable)

XU - Perform these procedures more often for vehicles subjected to severe use.

D - Have an authorized Polaris dealer or qualified person perform these services.

## MAINTENANCE

---

### **275 HOUR / 2750 MILES (4400 KM) SERVICE**

ITEM		REMARKS
XU /D	Brake Pads / Parking Brake Pads (INT'L)	Inspect pad wear; replace if worn beyond service limit
	Fuel System	Turn key on to pressurize fuel pump; check lines / fittings for leaks and abrasion
XU /D	Parking Brake Cable Adjustment (INT'L)	Inspect; adjust tension after first 25 hours
XU	Engine Breather	Inspect; clean
	Battery	Check terminals; clean; test
XU	Engine Oil & Filter Change	Change oil and filter, inspect used oil for contaminants
XU	Air Filter	Inspect; replace as needed
XU	Front Gearcase Lubricant	Inspect / add lubricant if needed
XU	Transmission Lubricant (AGL)	Inspect / add lubricant if needed

XU - Perform these procedures more often for vehicles subjected to severe use.

D - Have an authorized Polaris dealer or qualified person perform these services.

**300 HOUR / 3000 MILES (4800 KM) SERVICE**

ITEM		REMARKS
XU / D	Brake Pads / Parking Brake Pads (INT'L)	Inspect pad wear; replace if worn beyond service limit
	Fuel System	Turn key on to pressurize fuel pump; check lines / fittings for leaks and abrasion
XU / D	Parking Brake Cable Adjustment (INT'L)	Inspect; adjust tension after first 25 hours
XU	Engine Breather	Inspect; clean
	Battery	Check terminals; clean; test
XU	General Lubrication	Lubricate all fittings, pivots, cables, etc.
D	Throttle Pedal	Inspect; replace if it sticks
	Throttle Body Intake Ducts/Flange	Inspect ducts for proper sealing / air leaks
	Shift Cable / Linkage	Inspect; adjust as needed
D	Steering	Lubricate (if applicable)
XU	Front / Rear Suspension	Lubricate (if applicable)
D	Cooling System	Inspect coolant strength seasonally; pressure test system yearly
D	Drive Belt	Inspect; replace as needed
D	Clutches (Drive and Driven)	Inspect; clean; replace worn parts
XU	Engine Oil Lines/ Fasteners	Inspect for leaks and loose fittings
XU / D	Parking Brake Cable Adjustment (INT'L)	Inspect; adjust tension as needed
XU	Front Gearcase Lubricant	Change lubricant
XU	Transmission Lubricant (AGL)	Change lubricant
D	Fuel System	Check for leaks at fill cap, fuel line / rail, and fuel pump.
D	Spark Plug Inspection	Inspect; replace as needed; torque to specification
XU	Radiator	Inspect; clean external surfaces
XU	Cooling Hoses	Inspect for leaks; pressure test system
XU	Engine Mounts	Inspect, torque to specification

## MAINTENANCE

ITEM		REMARKS
	Exhaust Silencer / Pipe	Inspect
XU	Wiring	Inspect for wear, routing, security; inspect connectors subjected to water, mud, etc.
D	Front Wheel Bearings	Inspect; replace as needed
	Cam Chain Tensioner	Inspect/clean; replace as needed
XU	Shock Absorbers	Inspect for leaks, loose joints, and wear

XU - Perform these procedures more often for vehicles subjected to severe use.

D - Have an authorized Polaris dealer or qualified person perform these services.

**325 HOUR / 3250 MILES (5200 KM) SERVICE**

ITEM		REMARKS
XU / D	Brake Pads / Parking Brake Pads (INT'L)	Inspect pad wear; replace if worn beyond service limit
	Fuel System	Turn key on to pressurize fuel pump; check lines / fittings for leaks and abrasion
XU / D	Parking Brake Cable Adjustment (INT'L)	Inspect; adjust tension after first 25 hours
XU	Engine Breather	Inspect; clean
	Battery	Check terminals; clean; test
XU	Engine Oil & Filter Change	Change oil and filter, inspect used oil for contaminants
XU	Air Filter	Inspect; replace as needed
XU	Front Gearcase Lubricant	Inspect / add lubricant if needed
XU	Transmission Lubricant (AGL)	Inspect / add lubricant if needed

XU - Perform these procedures more often for vehicles subjected to severe use.

D - Have an authorized Polaris dealer or qualified person perform these services.

## MAINTENANCE

### **350 HOUR / 3500 MILES (5600 KM) SERVICE**

ITEM		REMARKS
XU /D	Brake Pads / Parking Brake Pads (INT'L)	Inspect pad wear; replace if worn beyond service limit
	Fuel System	Turn key on to pressurize fuel pump; check lines / fittings for leaks and abrasion
XU /D	Parking Brake Cable Adjustment (INT'L)	Inspect; adjust tension after first 25 hours
XU	Engine Breather	Inspect; clean
	Battery	Check terminals; clean; test
XU	Front Gearcase Lubricant	Inspect / add lubricant if needed
XU	Transmission Lubricant (AGL)	Inspect / add lubricant if needed
XU	General Lubrication	Lubricate all fittings, pivots, cables, etc.
D	Throttle Pedal	Inspect; replace if it sticks
	Throttle Body Intake Ducts/Flange	Inspect ducts for proper sealing / air leaks
	Shift Cable / Linkage	Inspect; adjust as needed
D	Steering	Lubricate (if applicable)
XU	Front / Rear Suspension	Lubricate (if applicable)
D	Cooling System	Inspect coolant strength seasonally; pressure test system yearly
D	Drive Belt	Inspect; replace as needed
D	Clutches (Drive and Driven)	Inspect; clean; replace worn parts
XU	Engine Oil Lines/ Fasteners	Inspect for leaks and loose fittings
XU	Shock Absorbers	Inspect for leaks, loose joints, and wear

XU - Perform these procedures more often for vehicles subjected to severe use.

D - Have an authorized Polaris dealer or qualified person perform these services.

**375 HOUR / 3750 MILES (6000 KM) SERVICE**

ITEM		REMARKS
XU / D	Brake Pads / Parking Brake Pads (INT'L)	Inspect pad wear; replace if worn beyond service limit
	Fuel System	Turn key on to pressurize fuel pump; check lines / fittings for leaks and abrasion
XU / D	Parking Brake Cable Adjustment (INT'L)	Inspect; adjust tension after first 25 hours
XU	Engine Breather	Inspect; clean
	Battery	Check terminals; clean; test
XU	Engine Oil & Filter Change	Change oil and filter, inspect used oil for contaminants
XU	Air Filter	Inspect; replace as needed
XU	Front Gearcase Lubricant	Inspect / add lubricant if needed
XU	Transmission Lubricant (AGL)	Inspect / add lubricant if needed

XU - Perform these procedures more often for vehicles subjected to severe use.

D - Have an authorized Polaris dealer or qualified person perform these services.

## MAINTENANCE

### **400 HOUR / 4000 MILES (6400 KM) SERVICE**

ITEM		REMARKS
XU /D	Brake Pads / Parking Brake Pads (INT'L)	Inspect pad wear; replace if worn beyond service limit
	Fuel System	Turn key on to pressurize fuel pump; check lines / fittings for leaks and abrasion
XU /D	Parking Brake Cable Adjustment (INT'L)	Inspect; adjust tension after first 25 hours
XU	Engine Breather	Inspect; clean
	Battery	Check terminals; clean; test
XU	General Lubrication	Lubricate all fittings, pivots, cables, etc.
D	Throttle Pedal	Inspect; replace if it sticks
	Throttle Body Intake Ducts/Flange	Inspect ducts for proper sealing / air leaks
	Shift Cable / Linkage	Inspect; adjust as needed
D	Steering	Lubricate (if applicable)
XU	Front / Rear Suspension	Lubricate (if applicable)
D	Cooling System	Inspect coolant strength seasonally; pressure test system yearly
D	Drive Belt	Inspect; replace as needed
D	Clutches (Drive and Driven)	Inspect; clean; replace worn parts
XU	Engine Oil Lines/ Fasteners	Inspect for leaks and loose fittings
XU /D	Parking Brake Cable Adjustment (INT'L)	Inspect; adjust tension as needed
XU	Front Gearcase Lubricant	Change lubricant
XU	Transmission Lubricant (AGL)	Change lubricant
D	Fuel System	Check for leaks at fill cap, fuel line / rail, and fuel pump.
D	Spark Plug Inspection	Inspect; replace as needed; torque to specification
XU	Radiator	Inspect; clean external surfaces
XU	Cooling Hoses	Inspect for leaks; pressure test system
XU	Engine Mounts	Inspect, torque to specification

## MAINTENANCE

ITEM		REMARKS
	Exhaust Silencer / Pipe	Inspect
XU	Wiring	Inspect for wear, routing, security; inspect connectors subjected to water, mud, etc.
D	Front Wheel Bearings	Inspect; replace as needed
D	Brake Fluid	Change every two years (DOT 4)
	Spark Arrestor	Clean daily if driven in mud / water; replace a damaged arrestor before operating
	Cam Chain Tensioner	Inspect/clean; replace as needed
D	Valve Clearance	Inspect; adjust as needed
XU	Shock Absorbers	Inspect for leaks, loose joints, and wear

XU - Perform these procedures more often for vehicles subjected to severe use.

D - Have an authorized Polaris dealer or qualified person perform these services.

## MAINTENANCE

---

### **425 HOUR / 4250 MILES (6800 KM) SERVICE**

ITEM		REMARKS
XU /D	Brake Pads / Parking Brake Pads (INT'L)	Inspect pad wear; replace if worn beyond service limit
	Fuel System	Turn key on to pressurize fuel pump; check lines / fittings for leaks and abrasion
XU /D	Parking Brake Cable Adjustment (INT'L)	Inspect; adjust tension after first 25 hours
XU	Engine Breather	Inspect; clean
	Battery	Check terminals; clean; test
XU	Engine Oil & Filter Change	Change oil and filter, inspect used oil for contaminants
XU	Air Filter	Inspect; replace as needed
XU	Front Gearcase Lubricant	Inspect / add lubricant if needed
XU	Transmission Lubricant (AGL)	Inspect / add lubricant if needed

XU - Perform these procedures more often for vehicles subjected to severe use.

D - Have an authorized Polaris dealer or qualified person perform these services.

**450 HOUR / 4500 MILES (7200 KM) SERVICE**

ITEM		REMARKS
XU / D	Brake Pads / Parking Brake Pads (INT'L)	Inspect pad wear; replace if worn beyond service limit
	Fuel System	Turn key on to pressurize fuel pump; check lines / fittings for leaks and abrasion
XU / D	Parking Brake Cable Adjustment (INT'L)	Inspect; adjust tension after first 25 hours
XU	Engine Breather	Inspect; clean
	Battery	Check terminals; clean; test
XU	Front Gearcase Lubricant	Inspect / add lubricant if needed
XU	Transmission Lubricant (AGL)	Inspect / add lubricant if needed
XU	General Lubrication	Lubricate all fittings, pivots, cables, etc.
D	Throttle Pedal	Inspect; replace if it sticks
	Throttle Body Intake Ducts/Flange	Inspect ducts for proper sealing / air leaks
	Shift Cable / Linkage	Inspect; adjust as needed
D	Steering	Lubricate (if applicable)
XU	Front / Rear Suspension	Lubricate (if applicable)
D	Cooling System	Inspect coolant strength seasonally; pressure test system yearly
D	Drive Belt	Inspect; replace as needed
D	Clutches (Drive and Driven)	Inspect; clean; replace worn parts
XU	Engine Oil Lines/ Fasteners	Inspect for leaks and loose fittings
XU	Shock Absorbers	Inspect for leaks, loose joints, and wear

XU - Perform these procedures more often for vehicles subjected to severe use.

D - Have an authorized Polaris dealer or qualified person perform these services.

## MAINTENANCE

---

### **475 HOUR / 4750 MILES (7600 KM) SERVICE**

ITEM		REMARKS
XU /D	Brake Pads / Parking Brake Pads (INT'L)	Inspect pad wear; replace if worn beyond service limit
	Fuel System	Turn key on to pressurize fuel pump; check lines / fittings for leaks and abrasion
XU /D	Parking Brake Cable Adjustment (INT'L)	Inspect; adjust tension after first 25 hours
XU	Engine Breather	Inspect; clean
	Battery	Check terminals; clean; test
XU	Engine Oil & Filter Change	Change oil and filter, inspect used oil for contaminants
XU	Air Filter	Inspect; replace as needed
XU	Front Gearcase Lubricant	Inspect / add lubricant if needed
XU	Transmission Lubricant (AGL)	Inspect / add lubricant if needed

XU - Perform these procedures more often for vehicles subjected to severe use.

D - Have an authorized Polaris dealer or qualified person perform these services.

**500 HOUR / 5000 MILES (8000 KM) SERVICE**

ITEM		REMARKS
XU / D	Brake Pads / Parking Brake Pads (INT'L)	Inspect pad wear; replace if worn beyond service limit
	Fuel System	Turn key on to pressurize fuel pump; check lines / fittings for leaks and abrasion
XU / D	Parking Brake Cable Adjustment (INT'L)	Inspect; adjust tension after first 25 hours
XU	Engine Breather	Inspect; clean
	Battery	Check terminals; clean; test
XU	General Lubrication	Lubricate all fittings, pivots, cables, etc.
D	Throttle Pedal	Inspect; replace if it sticks
	Throttle Body Intake Ducts/Flange	Inspect ducts for proper sealing / air leaks
	Shift Cable / Linkage	Inspect; adjust as needed
D	Steering	Lubricate (if applicable)
XU	Front / Rear Suspension	Lubricate (if applicable)
D	Cooling System	Inspect coolant strength seasonally; pressure test system yearly
D	Drive Belt	Inspect; replace as needed
XU	Engine Oil Lines/ Fasteners	Inspect for leaks and loose fittings
XU / D	Parking Brake Cable Adjustment (INT'L)	Inspect; adjust tension as needed
XU	Front Gearcase Lubricant	Change lubricant
XU	Transmission Lubricant (AGL)	Change lubricant
D	Fuel System	Check for leaks at fill cap, fuel line / rail, and fuel pump.
D	Spark Plug Inspection	Inspect; replace as needed; torque to specification
XU	Radiator	Inspect; clean external surfaces
XU	Cooling Hoses	Inspect for leaks; pressure test system
XU	Engine Mounts	Inspect, torque to specification
	Exhaust Silencer / Pipe	Inspect

## MAINTENANCE

ITEM		REMARKS
XU	Wiring	Inspect for wear, routing, security; inspect connectors subjected to water, mud, etc.
D	Clutches (Drive and Driven)	Inspect; clean; replace worn parts
D	Front Wheel Bearings	Inspect; replace as needed
D	Brake Fluid	Change every two years (DOT 4)
	Spark Arrestor	Clean daily if driven in mud / water; replace a damaged arrestor before operating
	Cam Chain Tensioner	Inspect; replace as needed
D	Valve Clearance	Inspect; adjust as needed
D	Spark Plug Replacement	Replace; torque to specification
XU	Coolant	Replace coolant
D	Toe Adjustment	Inspect periodically; adjust when parts are replaced
	Cam Chain Tensioner	Inspect/clean; replace as needed
XU / D	Shock Absorbers	Replace or rebuild (if applicable)

XU - Perform these procedures more often for vehicles subjected to severe use.

D - Have an authorized Polaris dealer or qualified person perform these services.

When the vehicle goes beyond 500 hours / 5000 miles (8000 km), return to the 25 hours / 250 miles (400 km) chart and start the interval process over.

## LUBRICATION RECOMMENDATIONS

Check and lubricate all components at the intervals outlined in the Periodic Maintenance Chart section, or more often under severe use, such as wet or dusty conditions. Items not listed in the chart should be lubricated at the general lubrication interval.

ITEM	LUBE	METHOD
Engine Oil	PS-4 5W-50 4-Cycle Oil and PS-4 Extreme Duty 10W-50 4-Cycle Oil	See page 143
Brake Fluid	DOT 4 Brake Fluid	Maintain level between fill lines. See page 166
Transmission Oil (Main Gearcase)	AGL Gearcase Lubricant & Transmission Fluid	See page 145.
Front Gearcase Fluid (Demand Drive)	Demand Drive Fluid	See page 147.
Prop Shaft	U-Joint Grease	Grease the middle and rear fittings.
Stabilizer Bar Bushings	All Season Grease or grease conforming to NLGI No. 2	Grease 2 fittings on front (if applicable) and 2 fittings on rear.

Lubricate as recommended.

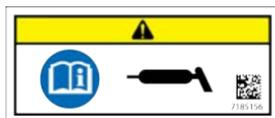

# MAINTENANCE

---

① Middle Prop Shaft Grease Fitting

② Rear Prop Shaft Grease Fitting

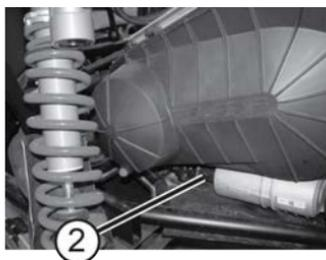
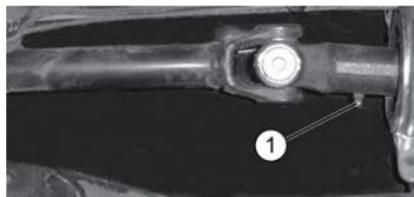

③ Rear Stabilizer Bar Grease Fitting

④ Front Stabilizer Bar Grease Fitting

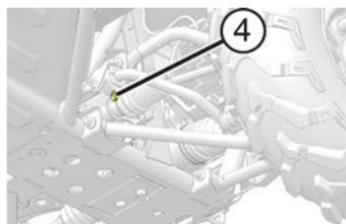
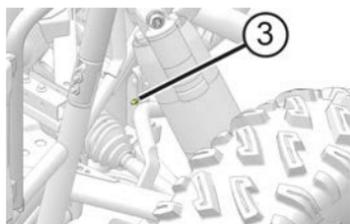

## ENGINE OIL

### OIL RECOMMENDATIONS

 **WARNING**

Vehicle operation with insufficient, deteriorated, or contaminated engine oil will cause accelerated wear and may result in engine seizure, accident, and injury. Always perform the maintenance procedures as outlined in the Periodic Maintenance Chart.

Ambient Temperature Range	Recommended Oil
-35 °F to +100 °F (-37 °C) to (+38 °C)	PS-4 5W-50 4-Cycle Oil
0 °F to 120 °F (-18 °C) to (+49 °C)	PS-4 Extreme Duty 10W-50 4-Cycle Oil

Oil may need to be changed more frequently if POLARIS oil is not used. Do not use automotive oil. Follow the manufacturer's recommendations for ambient temperature operation. Part numbers can be found in the POLARIS Products chapter.

**NOTICE**

Mixing brands or using a non-recommended oil may cause serious engine damage. Always use the recommended oil. Never substitute or mix oil brands.

Always check and change the oil at the intervals outlined in the Periodic Maintenance Chart. Always use the recommended engine oil.

## MAINTENANCE

---

### OIL CHECK

Always check the oil when the engine is cold. If the engine is hot when the oil is checked, the level will appear to be overfull.

Access the oil filter ① and oil check dipstick ② through the engine access panel located behind the seats.

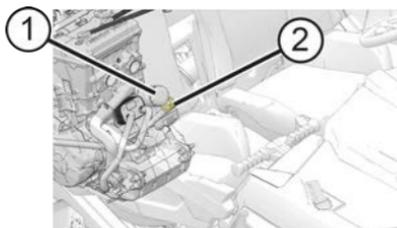

1. Position the vehicle on a level surface.
2. Place the transmission in PARK.
3. Engage the park brake.

#### NOTE

Always check the oil when the engine is cold.

4. Remove the seats and remove the engine access panel.
5. Remove the dipstick . Wipe it dry with a clean cloth.
6. Reinstall the dipstick completely. Remove the dipstick and check the oil level.
7. Remove the oil fill cap ③ to add the recommended oil as needed. Maintain the oil level between the minimum and maximum marks on the dipstick. Do not overfill.

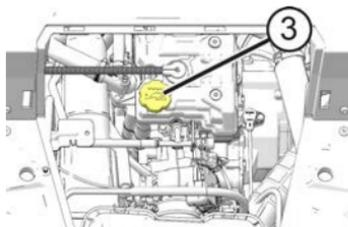

8. Reinstall the fill cap. Reinstall the dipstick.

## OIL AND FILTER CHANGE

Always change the oil and filter at the intervals outlined in the Periodic Maintenance Chart section. Always change the oil filter whenever changing oil.

Access the oil check dipstick and oil filter through the engine access panel located behind the seats.

The crankcase drain plug is located on the bottom of the crankcase. Access the drain plug through the access hole under the crankcase.

1. Position the vehicle on a level surface. Place the transmission in PARK.
2. Engage the park brake.
3. Clean the area around the crankcase drain plug.

### CAUTION

Hot oil can cause burns to skin. Do not allow hot oil to contact skin.

4. Place a drain pan under the engine crankcase and remove the drain plug. Allow the oil to drain completely.
5. Remove the seats and remove the engine access panel.
6. Using an oil filter wrench, turn the filter ① counterclockwise to remove it.

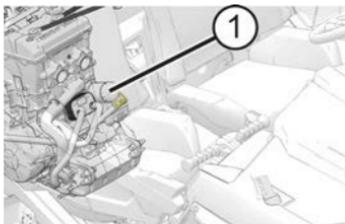

7. Using a clean dry cloth, clean the filter sealing surface on the crankcase.
8. Lubricate the o-ring on the new filter with a film of fresh engine oil. Check to make sure the o-ring is in good condition.
9. Install the new filter and turn by hand until the filter gasket contacts the sealing surface, then turn an additional 3/4 turn.
10. Reinstall the crankcase drain plug. Torque to 12 ft-lbs (16 N·m).
11. Remove the oil fill cap and add 2.5 qt (2.4 L) of recommended oil (listed in the Oil Recommendations section). Reinstall the fill cap.
12. Start the engine and check for leaks.
13. Stop the engine and wait 15 seconds before removing the dipstick.

## MAINTENANCE

---

14. Remove the dipstick. Wipe it dry with a clean cloth.
15. Reinstall the dipstick completely. Remove the dipstick and check the oil level.
16. Add oil as necessary to bring the level to the upper mark on the dipstick. Do not overfill.
17. Reinstall the dipstick.
18. Reinstall the oil fill cap.
19. Dispose of used filter and oil properly.

## TRANSMISSION (MAIN GEARCASE)

Always check and change the fluid at the intervals outlined in the Periodic Maintenance Chart section. Refer to the Gearcase Specifications Chart section for recommended lubricants, capacities and torque specifications.

### FLUID CHECK

The fill plug ① is located on the rear of the gearcase. Maintain the fluid level at the bottom of the fill plug hole.

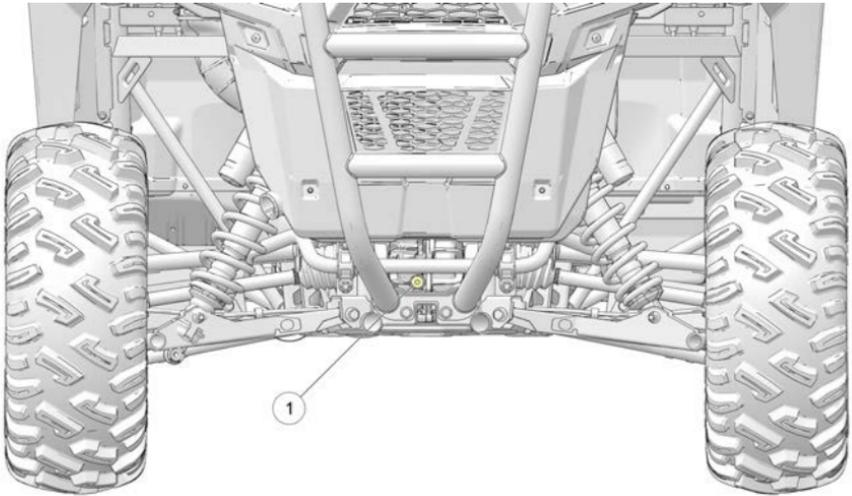

1. Position the vehicle on a level surface.
2. Remove the fill plug.
3. Check the fluid level.
4. Add the recommended fluid (listed in the Gearcase Specifications Chart section of this manual) to the bottom of the fill plug hole. Do not overfill.
5. Reinstall the fill plug. Torque to specification (listed in the Gearcase Specifications Chart).

## MAINTENANCE

---

### FLUID CHANGE

The drain plug ① is located on the bottom of the gearcase. Access the drain plug through the drain hole in the skid plate.

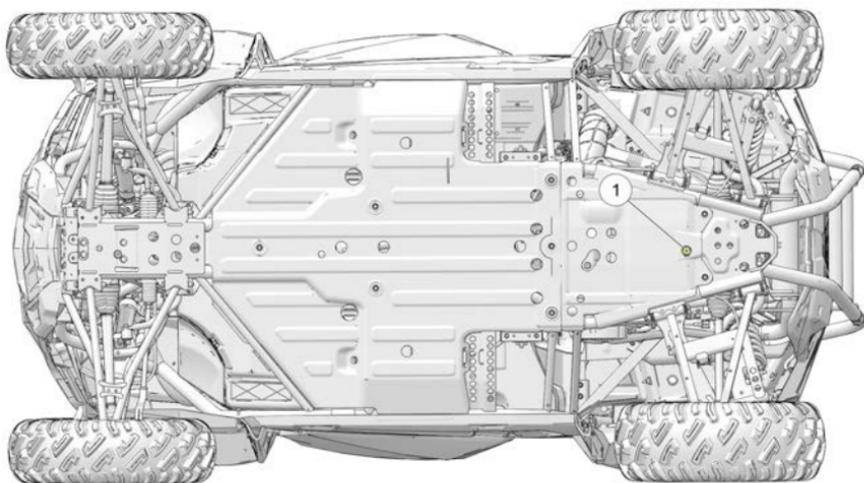

1. Remove the fill plug.
2. Place a drain pan under the drain plug.
3. Remove the drain plug. Allow the fluid to drain completely.
4. Clean the drain plug.
5. Reinstall the drain plug. Torque to specification (listed in the Gearcase Specification Chart of this manual).
6. Add the recommended fluid (listed in the Gearcase Specification Chart) to the bottom of the fill plug hole. Do not overfill.
7. Reinstall the fill plug. Torque to specification (listed in the Gearcase Specification Chart).
8. Check for leaks. Discard used fluid properly.

## DEMAND DRIVE UNIT (FRONT GEARCASE)

Always check and change the fluid at the intervals outlined in the Periodic Maintenance Chart. Refer to the Gearcase Specifications Chart section for recommended lubricants, capacities and torque specifications.

### DEMAND DRIVE FLUID CHECK

The fill plug ① is located on the bottom right side of the demand drive unit. Maintain the fluid level even with the bottom thread of the fill plug hole.



1. Position the vehicle on a level surface.
2. Remove the fill plug. Check the fluid level.
3. Add the recommended fluid (listed in the Gearcase Specification Chart of this manual) to the bottom thread of the fill plug hole.
4. Reinstall the fill plug. Torque to specification (listed in the Gearcase Specification Chart).

### DEMAND DRIVE FLUID CHANGE

The demand drive drain plug ① is located on the bottom of the gearcase.

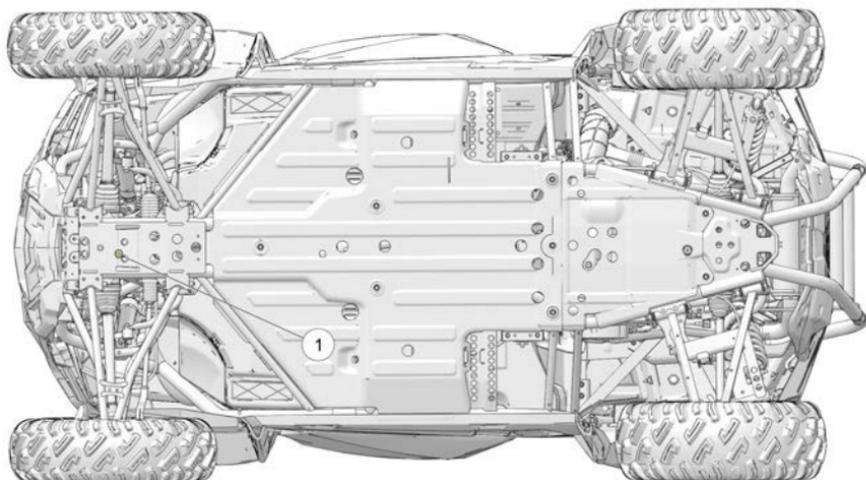

1. Remove the fill plug.
2. Place a drain pan under the drain plug.
3. Remove the drain plug. Allow the fluid to drain completely.
4. Clean the drain plug.
5. Reinstall the drain plug. Torque to specification (listed in the Gearcase Specification Chart of this manual).
6. Add the recommended fluid (listed in the Gearcase Specification Chart) to the bottom thread of the fill plug hole.
7. Reinstall the fill plug. Torque to specification listed in the Gearcase Specification Chart).
8. Check for leaks. Discard used fluid properly.

## GEARCASE SPECIFICATION CHART

Use of other fluids may result in improper operation of components. See the Polaris Products section for the part numbers.

<b>Gearcase</b>	<b>Lubricant</b>	<b>Capacity</b>	<b>Fill Plug Torque</b>	<b>Drain Plug Torque</b>
Transmission (Main Gearcase)	AGL Gearcase Lubricant & Transmission Fluid	44 fl oz (1300 mL)	10-14 ft-lbs (14-19 N·m)	10-14 ft-lbs (14-19 N·m)
Demand Drive Unit (Front Gearcase)	Demand Drive Fluid	7.5 fl oz (222 mL)	8-10 ft-lbs (11-14 N·m)	8-10 ft-lbs (11-14 N·m)

# SPARK PLUGS

## SPARK PLUG GAP / TORQUE

Electrode Gap	Spark Plug Torque
0.028-0.031 in (0.7-0.8 mm)	7 ft-lbs (10 N·m)

### NOTICE

Using non-recommended spark plugs can result in serious engine damage. Always use POLARIS-recommended spark plugs or their equivalent. Refer to the Specifications section for details.

Spark plug condition is indicative of engine operation. The spark plug firing end condition should be read after the engine is warmed up and the vehicle is driven at higher speeds. Immediately check the spark plug for correct color.

### CAUTION

A hot exhaust system and engine can cause burns. Wear protective gloves when removing a spark plug for inspection.

## SPARK PLUG REMOVAL AND REPLACEMENT

1. Remove the cargo box access panel to access the spark plugs ①.

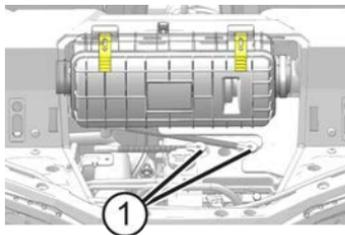

2. Clean the area around the spark plugs before removing the plugs.
3. Remove the spark plug caps.
4. Using the spark plug wrench provided in the tool kit, remove the plugs by rotating them counterclockwise.
5. Reverse the procedure for spark plug installation. Torque to specification.

## SPARK PLUG CONDITION

### ***NORMAL PLUG***

The normal insulator tip is gray, tan or light brown. There will be few combustion deposits. The electrodes are not burned or eroded. This indicates the proper type and heat range for the engine and the service.

<i>NOTICE</i>
The tip should not be white. A white insulator tip indicates overheating, caused by use of an improper spark plug or incorrect throttle body adjustments.

### ***WET FOULED PLUG***

The wet fouled insulator tip is black. A damp oil film covers the firing end. There may be a carbon layer over the entire nose. Generally, the electrodes are not worn. Fouling may be caused by excessive oil or by frequent short trips, especially in cold weather.

## FUSE / RELAY CENTER

If the engine stops or will not start, if the power steering stops working (if equipped), or if you experience other electrical failures, a fuse may need replacement. Locate and correct any short circuits that may have caused the blown fuse, then replace the fuse. The fuse/relay center ① is located near the driver's left knee.

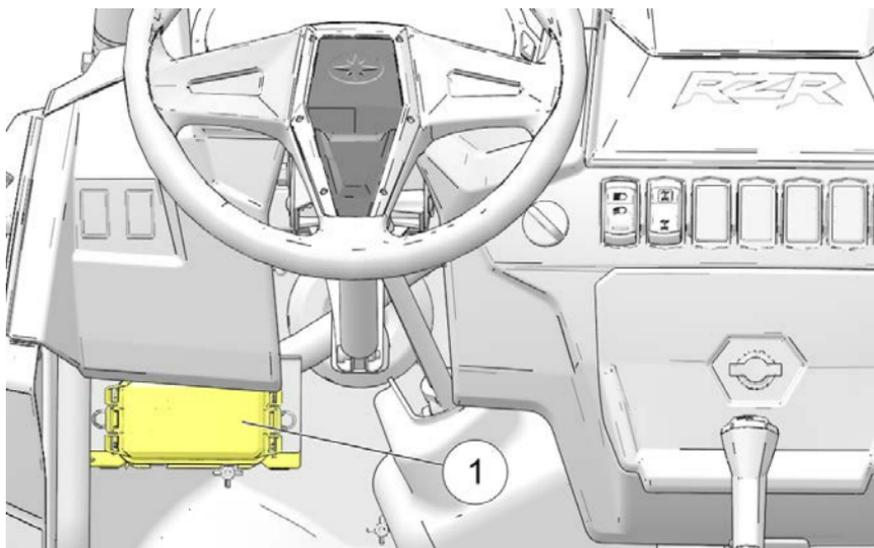

LABEL	VALUE	FUNCTION
FAN	20A Circuit Breaker	Fan
EFI	10A Fuse	EFI Relay, Injectors, Coil, ECM, Chassis Relay Coil, Fan Relay Coil, Fuel Pump Relay Coil
KEY	10A Fuse	Gauge, EFI Relay Coil, EPS Relay Coil, Key Switch
TERM	10A Fuse	Under Hood Terminal Block, Interior LED
EPS	20A Fuse	Power Steering (optional)
LIGHTS	15A Fuse	Headlights, Taillights, Dash Lights

## MAINTENANCE

LABEL	VALUE	FUNCTION
DRIVE	10A Fuse	All-Wheel Drive, TURF (optional)
ACCESSORY	10A Fuse (RZR) 15A Fuses (2) (RZR S4)	12V Receptacle

### COOLING SYSTEM

The engine coolant level is maintained by the recovery system. The recovery system components are the overflow bottle, radiator vent fitting, radiator pressure cap and connecting hose.

As coolant operating temperature increases, the expanding (heated) excess coolant is forced out of the radiator, past the pressure cap, and into the overflow bottle. As engine coolant temperature decreases, the contracting (cooled) coolant is drawn back up from the tank, past the pressure cap, and into the radiator.

#### TIP

Some coolant level drop on new vehicles is normal as the system is purging itself of trapped air. Observe coolant levels and maintain as recommended by adding coolant to the overflow bottle.

### ADDING OR CHANGING COOLANT

POLARIS recommends the use of POLARIS Antifreeze 50/50 Premix. This antifreeze is already premixed and ready to use. Do not dilute with water. See the Polaris Products section for the part numbers.

To ensure that the coolant maintains its ability to protect the engine, we recommend that the system be completely drained every five (5) years and fresh Antifreeze 50/50 Premix added.

Any time the cooling system has been drained for maintenance or repair, replace the coolant with fresh Antifreeze 50/50 Premix.

### RADIATORS AND COOLING FAN

Always check and clean the screens and radiator fins at the intervals outlined in the Periodic Maintenance Chart section. Do not obstruct or deflect air flow through the radiators by installing unauthorized accessories in front of the radiators or behind the cooling fan. Interference with radiator air flow can lead to overheating and consequent engine damage.

#### NOTICE

Washing the vehicle with a high-pressure hose could damage radiator fins and impair a radiator's effectiveness. Using a high-pressure system is not recommended.

## RADIATOR COOLANT LEVEL / CHANGING COOLANT

This procedure is required only if the cooling system has been drained for maintenance and/or repair. If the overflow bottle ③ has run dry, the level in the radiator should also be inspected.

### CAUTION

Escaping steam can cause burns. Never remove the pressure cap while the engine is warm or hot. Always allow the engine to cool before removing the pressure cap.

1. Remove the hood. See the Hood section for details.
2. Slowly remove the radiator pressure cap ②.
3. View the coolant level through the opening.
4. Use a funnel and slowly add coolant as needed.
5. Before reinstalling the pressure cap, bleed the system of trapped air. Remove the engine access panel behind the seats and use a flat-blade screwdriver to turn the bleed screw ① slightly, allowing the air to escape. Slowly add additional coolant to the radiator until air no longer escapes and only coolant flows from the bleed hole, then tighten the bleed screw.
6. Reinstall the pressure cap.

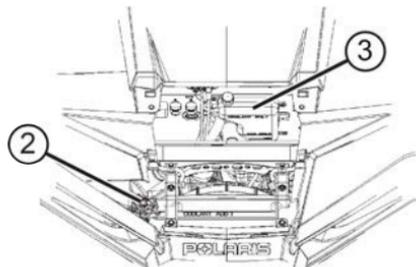
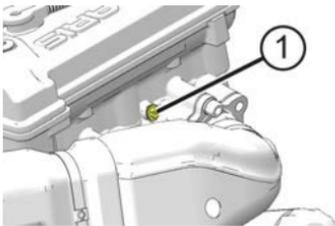

### TIP

Use of a non-standard pressure cap will not allow the recovery system to function properly. See your dealer for the correct replacement part.

## MAINTENANCE

---

### OVERFLOW BOTTLE COOLANT LEVEL

Always check and change the coolant at the intervals outlined in the Periodic Maintenance Chart section. Maintain the coolant level between the minimum and maximum marks on the bottle (when the fluid is cool). If the overflow bottle has run dry, the level in the radiator should also be inspected.

1. Position the vehicle on a level surface.
2. Remove the hood. See the Hood section for details.
3. View the coolant level in the overflow bottle ①.

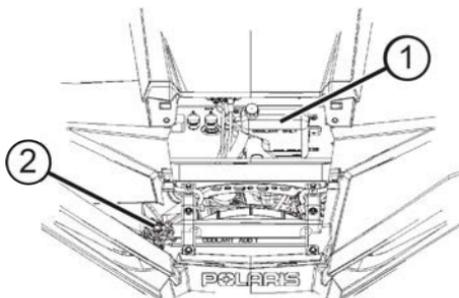

4. Remove the cap ② and use a funnel to add coolant as needed to maintain the level between the two marks.
5. Reinstall the cap.

#### TIP

If coolant must be added often, or if the overflow bottle runs completely dry, there may be a leak in the system. Have the cooling system inspected by your POLARIS dealer or authorized person.

## POLARIS VARIABLE TRANSMISSION (PVT) SYSTEM

### WARNING

Failure to comply with the instructions in this warning can result in severe injury or death.

Do not modify any component of the PVT system. Doing so may reduce its strength so that a failure may occur at a high speed. The PVT system has been precision balanced. Any modification will cause the system to be out of balance, creating vibration and additional loads on components.

The PVT system rotates at high speeds, creating large amounts of force on clutch components. As the owner, you have the following responsibilities for your own safety and the safety of others:

- Always follow all recommended maintenance procedures. Always look for and remove debris inside and around the clutch and vent system when replacing the belt.
- See your dealer or other qualified service person as recommended in the owner's manual and on safety labels.
- This PVT system is intended for use on POLARIS products only. Do not install it in any other product.
- Always make sure the PVT housing is securely in place during operation.

Belt slip is responsible for creating excessive heat that destroys belts, wears clutch components and causes outer clutch covers to fail. Switch to low range while operating at slower speeds to extend the life of the PVT components (belt, cover, etc.).

### BELT REPLACEMENT / DEBRIS REMOVAL

**⚠ WARNING**

Failure to remove ALL debris when replacing the belt could result in vehicle damage, loss of control and severe injury or death.

If a belt fails, always clean any debris from the duct and from the clutch and engine compartments when replacing the belt.



1. Allow hot components to cool before performing this procedure.
2. Remove the engine access cover and thoroughly clean all debris from the aluminum debris basket ① and from the engine compartment.

3. Remove the clutch cover screws and open the clutch cover. (It does not have to be removed from the vehicle.) Remove all debris wrapped in and around the PVT system.

### TIP

Use the shock/clutch tool from the tool kit to slightly open the sheaves to aid in debris removal and belt installation.

Insert hooked end of tool



Apply force to opposite end of tool to spread sheaves



4. Remove ALL DEBRIS from the entire clutch air duct passage ②.

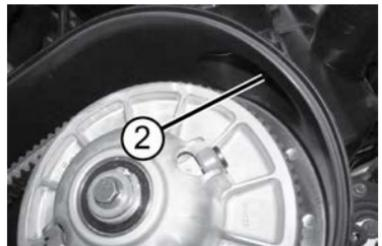

5. Check for signs of damage to seals on the transmission and engine. See your dealer promptly for service if any seals appear to be damaged.

### TIP

Belt slip is responsible for creating excessive heat that destroys belts, wears clutch components and causes outer clutch covers to fail. Switch to low range while operating at slower speeds to extend the life of the PVT components (belt, cover, etc.).

## MAINTENANCE

---

### PVT DRYING

There may be some instances when water is accidentally ingested into the PVT system. Use the following instructions to dry it out before operating.

#### NOTICE

When washing the vehicle, always avoid spraying water directly toward the PVT intake duct. See the Washing the Vehicle section for details.

1. Remove the clutch cover drain plug.
2. Allow the water to drain. Reinstall the drain plug.
3. Place the transmission in PARK. Apply the brakes.
4. Start the engine.
5. Apply varying throttle for 10-15 seconds to expel the moisture and air-dry the belt and clutches. Do not hold the throttle wide open for more than 10 seconds.
6. Allow the engine RPM to settle to idle speed. Apply the brakes. Shift the transmission to the lowest available range.
7. Test for belt slippage. If the belt slips, repeat the process.
8. Your vehicle requires service as soon as possible. Your POLARIS dealer or authorized person can assist.

## FILTER SYSTEMS

### AIR FILTER

Always change the air filter at the intervals outlined in the Periodic Maintenance Chart section.

1. Remove the cargo box access panel.
2. Clean all dirt and debris from the air box area.
3. Unlatch the two (2) air box cover straps ① and carefully remove the air box cover.

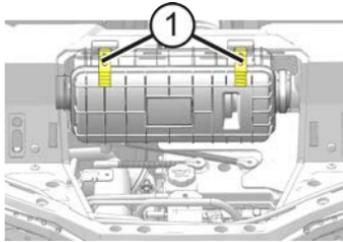

4. Inspect the air filter ② and air box for dirt, debris or water.

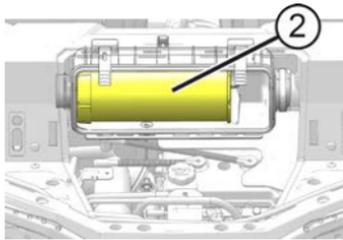

5. To remove the filter, slide the filter toward the passenger's side of the vehicle.
6. With the filter removed, clean the intake tube and air box thoroughly. Wipe well with a clean, dry cloth.

#### NOTICE

Dirt or debris in the intake tube could result in severe engine damage. Always clean all dirt and debris from the intake tube before installing the filter.

## MAINTENANCE

---

7. Reinstall the air filter (if clean) or install a new air filter (if soiled). Do not attempt to clean the air filter.

### NOTICE

Use of a non-POLARIS-approved air filter may cause engine damage. Always use a POLARIS-approved replacement filter. Please see your POLARIS dealer or authorized person.

8. Make sure that there are no gaps between the filter and the driver's side of the air box.
9. Reinstall the air box cover. Make sure the tabs are properly positioned into the hinge.
10. Secure the two (2) cover straps.
11. Reinstall the cargo box access panel.

## SPARK ARRESTER

### WARNING

Failure to heed the following warnings while servicing the spark arrester could result in serious injury or death.

- Do not perform clean-out immediately after the engine has been run, as the exhaust system becomes very hot. Serious burns could result from contact with the exhaust components. Allow components to cool sufficiently before proceeding.
- Wear eye protection and gloves.
- Never operate without the spark arrester.
- Never run the engine in an enclosed area. Exhaust contains poisonous carbon monoxide gas that can cause loss of consciousness or death in a very short time.

Periodically clean the spark arrester to remove accumulated carbon. A plugged spark arrester will affect engine performance. Clean daily when driving in mud and water. Replace a cracked or damaged arrester before operating.

1. Remove the arrester retaining bolt ① and nut ②.
2. Remove the arrester from the end of the muffler ③.

3. Use a non-synthetic brush to clean the arrester screen ④. A synthetic brush may melt if components are warm. If necessary, blow debris from the screen with compressed air.

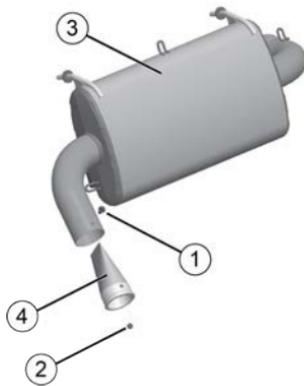

4. Inspect the screen for wear and damage. Replace a worn or damaged screen.
5. Reinstall the arrester. Torque bolt to 9-11 ft-lbs (12-15 N·m).

### BRAKES

 **WARNING**

Operating the vehicle with a spongy brake pedal can result in loss of braking, which could cause an accident resulting in severe injury or death. Never operate the vehicle with a spongy-feeling brake pedal.

The front and rear brakes are hydraulic disc type brakes activated by the brake pedal.

 **CAUTION**

Brake discs can become extremely hot after operation. Allow the discs to cool before performing maintenance to prevent risk of burns.

Always check brake pedal travel and the brake fluid reservoir level before each use of the vehicle. When applied, the brake pedal should feel firm. Any sponginess would indicate a possible fluid leak or low brake fluid level, which must be corrected before riding. See the Brake Fluid section for further details.

If you discover any irregularities in brake system operation, including excessive pedal travel, contact your dealer for proper diagnosis and repairs.

## BRAKE INSPECTION

### WARNING

Do not apply WD-40® or any petroleum product to brake discs. These types of products are flammable and may also reduce the friction between the brake pad and caliper.

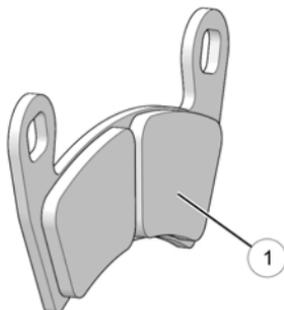

1. Check the brake system for fluid leaks.
2. Check the brake pedal for excessive travel or a spongy feel.
3. Check the friction pads for wear, damage and looseness.
4. Check brake discs for signs of cracks, excessive corrosion, warping or other damage. Clean any grease using an approved brake cleaner or alcohol.
5. Inspect the brake disc spline and pad wear surface for excessive wear. Change pads ① when worn to 0.040 in (1.0 mm).

### BRAKE FLUID

#### WARNING

After opening a bottle of brake fluid, always discard any unused portion. Never store or use a partial bottle. Brake fluid is hygroscopic, meaning it rapidly absorbs moisture from the air. The moisture causes the boiling temperature of the brake fluid to drop, which can lead to early brake fade and the possibility of accident or severe injury.

Inspect the level of the brake fluid before each operation. If the fluid level is low add DOT 4 brake fluid only. See the Polaris Products section for the part numbers.

Change the brake fluid every two years and any time the fluid becomes contaminated, the fluid level is below the minimum, or if the type and brand of the fluid in the reservoir are unknown. Access the brake fluid reservoir through the left front wheel well.

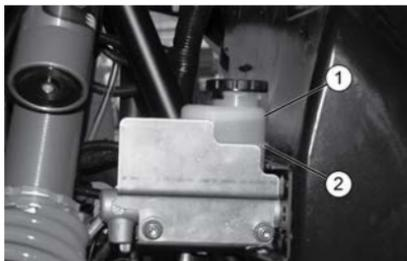

1. Position the vehicle on a level surface.
2. Place the transmission in PARK.
3. View the brake fluid level in the reservoir. The level should be between the maximum ① and minimum ② level lines.
4. If the fluid level is lower than the lower level line, add brake fluid to the upper line.
5. Apply the brake forcefully for a few seconds and check for fluid leakage around the fittings.

## SUSPENSION SETTINGS

### SACHS® SHOCKS (IF EQUIPPED)

The front and rear preloads are adjustable.

The suspensions are set on the lowest setting at the factory. This setting is appropriate for nearly all riding conditions.

If desired, the suspension may be adjusted to maintain vehicle clearance height when carrying loads. Elevate the vehicle slightly for easier adjustment.

*Always heed the following rules if you make adjustments to this suspension.*

- Always return the suspension to the lowest setting after the load is removed from the vehicle. The increased suspension height will negatively impact vehicle stability when operating without a load.
- Always apply the same adjustment setting to *all four wheels*.
- Never operate the vehicle on the highest or second highest preload settings without a total combined payload in the vehicle of 450 lb (204 kg) or more. Payload includes the driver, passenger, POLARIS-approved accessories and cargo. Never exceed the stated load capacity for the vehicle.

- ① Adjustment Cam
- ② Highest (Stiffest) Setting
- ③ Lowest (Softest) Setting

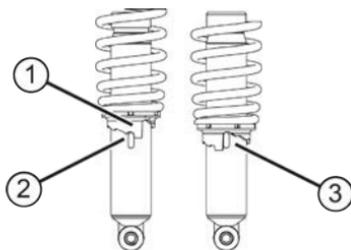

## MAINTENANCE

### FOX® SHOCKS (IF EQUIPPED)

#### Spring Preload Adjustment

The factory setting is appropriate for nearly all riding conditions. If desired, the suspension may be adjusted to maintain ground clearance when carrying additional weight.



To adjust the preload, do the following:

1. Elevate the vehicle to allow the suspension to fully extend.
2. Loosen the jam nut and back it away from the adjusting ring.
3. Turn the adjusting ring to the left to add preload. Turn the adjusting ring to the right to remove preload.
4. Tighten the jam nut firmly against ring.

LOCATION	TRAIL 900	TRAIL S 900
Front	7.94 in (202 mm)	4.41 in (112 mm)
Rear	3.31 in (84 mm)	0.74 in (19 mm)

*Follow these guidelines if you make adjustments to this suspension.*

- Always return the suspension to the factory setting after the load is removed from the vehicle. The increased suspension height will negatively impact vehicle stability when operating without a load.
- Always apply the same adjustment setting to all four wheels.

Do not increase the spring preload by more than 1 in (25.4 mm) over the factory setting.

## FOX® SHOCK COMPRESSION ADJUSTMENT (IF EQUIPPED)

The compression damping clicker knob is located at the top of the shock reservoir.

1. Turn the clicker clockwise to increase compression damping.
2. Turn the clicker counter-clockwise to decrease compression damping.



FACTORY PRELOAD SETTINGS	
Setting	Compression Damping
Softest	Full counter-clockwise position (24 clicks)
Factory	Center position (12 Clicks)
Firmest	Full clockwise position (0 clicks)

**⚠ WARNING**

Uneven adjustment may cause poor handling of the vehicle, which could result in an accident. Always adjust both the left and right spring preloads equally or have your POLARIS dealer/authorized person perform the adjustments.

## MAINTENANCE

### WALKER EVANS SHOCKS (IF EQUIPPED)

The factory setting is appropriate for nearly all riding conditions. If desired, the suspension may be adjusted to maintain vehicle clearance height when carrying loads.

To adjust the preload, do the following:

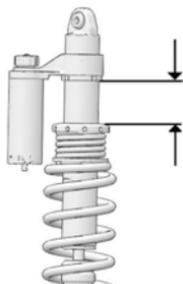

1. Elevate the vehicle to allow the suspension to fully extend.
2. Turn the adjusting ring to the left to increase preload for a higher ride height.  
Turn the adjusting ring to the right to decrease preload for a lower ride height.

LOCATION	MEASUREMENT
Front	6.10 in (155 mm)
Rear	3.31 in (84 mm)

*Follow these guidelines if you make adjustments to this suspension.*

- Always return the suspension to the factory setting after the load is removed from the vehicle. The increased suspension height will negatively impact vehicle stability when operating without a load.
- Always apply the same adjustment setting to all four wheels.

Do not increase the spring preload by more than 1 in (25.4 mm) over the factory setting.

## WALKER EVANS SHOCK COMPRESSION ADJUSTMENT (IF EQUIPPED)

The compression damping clicker knob is located at the top of the shock reservoir.

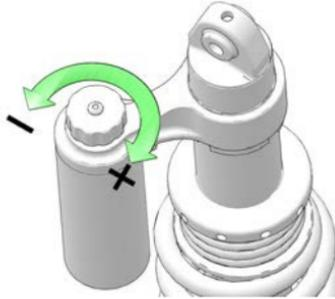

1. Turn the clicker clockwise to increase compression damping.
2. Turn the clicker counter-clockwise to decrease compression damping.

FACTORY PRELOAD SETTINGS	
Setting	Compression Damping
Softest	Full counter-clockwise position (16 clicks)
Factory	Center position (8 Clicks)
Firmest	Full clockwise position (0 clicks)

## TIRES

### WARNING

Operating your vehicle with worn tires will increase the possibility of skidding, loss of control and an accident, which could result in serious injury or death. Always replace tires when the tread depth measures 1/8 in (3 mm) or less.

Improper tire inflation or the use of non-standard size or type of tires may adversely affect vehicle handling, which could result in vehicle damage or personal injury. Always maintain proper tire pressure. Always use POLARIS-approved size and type of tires for this vehicle when replacing tires.

## TIRE TREAD DEPTH

Always replace tires when tread depth is worn to 1/8 in (3 mm) ① or less.

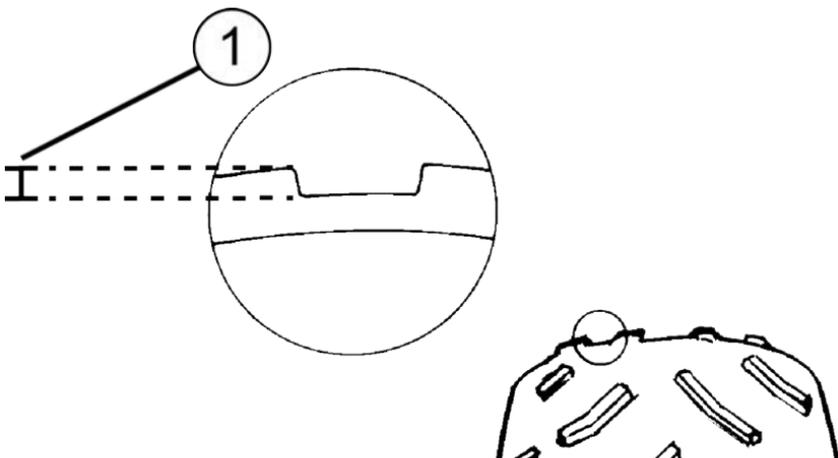

## AXLE AND WHEEL NUT TORQUE SPECIFICATIONS

Inspect the following items occasionally for tightness, and if they've been loosened for maintenance service. *Do not lubricate the stud or the lug nut.*

Lug Nut (Aluminum Wheels) 	Front and Rear	120 ft-lbs (162.7 N·m)
Lug Nut (Steel Wheels)	Front and Rear	60 ft-lbs (81.3 N·m)
Hub Retaining Nut	Front and Rear	110 ft-lbs (149 N·m)

## MAINTENANCE

---

### WHEEL REMOVAL

1. Position the vehicle on a level surface.
2. Place the transmission in PARK. Stop the engine.
3. Engage the park brake.
4. Loosen the wheel nuts slightly.
5. Elevate the side of the vehicle by placing a suitable stand under the frame.
6. Remove the wheel lug nuts. Remove the wheel.

### WHEEL INSTALLATION

#### WARNING

Improperly installed wheels can adversely affect tire wear and vehicle handling, which can result in serious injury or death. Always ensure that all nuts are torqued to specification. Do not service axle nuts that have a cotter pin installed. Your POLARIS dealer can assist.

1. Place the transmission in PARK.
2. Place the wheel in the correct position on the wheel hub. Be sure the valve stem ① is toward the outside and rotation arrows on the tire point toward forward rotation.
3. Attach the wheel nuts and finger tighten.
4. Carefully lower the vehicle to the ground.
5. Torque the wheel nuts to specification. See the Axle and Wheel Nut Torque Specifications section for details.



Right Rear Wheel  
(type varies by model)

## LIGHTS

Headlight and taillight lenses become dirty during normal operation. Clean all lights frequently to ensure a clear field of vision as well as visibility to other vehicles.

### TIP

#### LED LAMPS

If an LED headlamp appears to have moisture or fogging *inside* the lens, disconnect the wiring harness from the headlamp(s) for a few days to allow the moisture to clear out.

### TIP

#### HALOGEN LAMPS

When servicing a halogen lamp, don't touch the lamp with bare fingers. Oil from your skin leaves a residue, causing a hot spot that will shorten the life of the lamp.

## TAILLIGHT / BRAKE LIGHT / TURN SIGNAL LAMP REPLACEMENT

The taillight assembly is not serviceable. If the taillight or brake light fails to operate properly, replace the entire taillight assembly.

## HEADLIGHT REPLACEMENT

If a headlight becomes damaged or inoperable, the entire headlight assembly must be replaced. Do not operate this vehicle at night or in low light conditions until the headlight is replaced. Always make sure lights are adjusted properly for best visibility.

## MAINTENANCE

---

### HEADLIGHT BEAM ADJUSTMENT

The headlight beam can be adjusted slightly upward or downward and to the left or right.

1. Position the vehicle on a level surface. The headlight should be approximately 25 ft (7.6 m) from a wall.

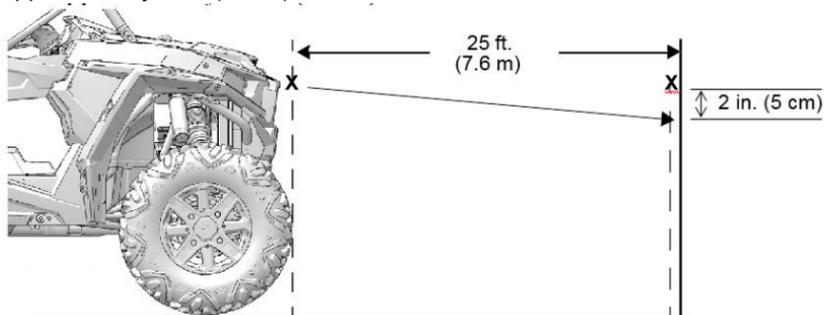

2. Place the transmission in PARK.
3. Measure the distance from the floor to the center of the headlight and make a mark on the wall at the same height.
4. Apply the brakes. Start the engine. Turn the headlights to high beam.

5. Include the weight of a rider on the seat while performing this step. Observe the headlight aim. As a starting point, the most intense part of the headlight beam should be 2 in (5 cm) below the mark on the wall. Adjust to operator preference.
6. Tighten or loosen the three (3) headlight screws ① on the rear of the headlight to adjust the beam upward or downward or to the left or right.

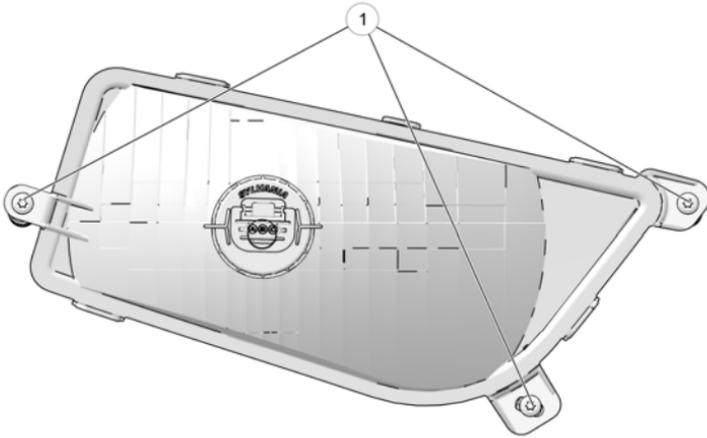

## VEHICLE IMMERSION

### NOTICE

If your vehicle becomes immersed, major engine damage can result if the machine is not thoroughly inspected. Take the vehicle to your dealer before starting the engine.

If it's impossible to take your vehicle to a dealer before starting it, follow the steps outlined below.

1. Move the vehicle to dry land.
2. Check the air box. See the Air Filter section for details. If water is present, dry the air box and replace the filter with a new filter.
3. Dry the spark plug wells with a clean cloth, then remove the spark plugs.
4. Turn the engine over several times.
5. Dry the spark plugs and reinstall them, or install new plugs.
6. Attempt to start the engine. If necessary, repeat the drying procedure.

## MAINTENANCE

---

7. Take the vehicle to your dealer for service as soon as possible, whether you succeed in starting it or not.
8. If water has been ingested into the PVT follow the procedures in the PVT Drying section.

## STEERING WHEEL INSPECTION

Check the steering wheel for specified freeplay and smooth operation at the intervals outlined in the Periodic Maintenance Chart.

1. Position the vehicle on level ground.
2. Lightly turn the steering wheel left and right.
3. There should be 0.8-1.0 in (20-25 mm) of freeplay.
4. If there is excessive freeplay or strange noises, or if the steering feels rough or “catchy,” have the steering system inspected by an authorized POLARIS dealer or other qualified personnel.

---

## BATTERY

 **WARNING**

Improperly connecting or disconnecting battery cables can result in an explosion and cause serious injury or death. When removing the battery, always disconnect the negative (black) cable first. When reinstalling the battery, always connect the negative (black) cable last.

Your vehicle has a low-maintenance battery. Always keep battery terminals and connections free of corrosion. If cleaning is necessary, remove the corrosion with a stiff wire brush. Wash with a solution of one tablespoon baking soda and one cup water. Rinse well with tap water and dry off with clean shop towels. Coat the terminals with dielectric grease or petroleum jelly.

### BATTERY REMOVAL

1. Remove the driver's seat (RZR) or the left rear passenger seat (RZR 4). See the Seats section for details.
2. Disconnect the black (negative) battery cable first.
3. Disconnect the red (positive) battery cable last.
4. Remove the battery hold-down strap.
5. Lift the battery out of the vehicle.

### BATTERY INSTALLATION

Using a new battery that has not been fully charged can damage the battery and result in a shorter life. It can also hinder vehicle performance. Follow the instructions in the Battery Charging section before installing the battery.

1. Ensure that the battery is fully charged.
2. Place the battery in the battery holder.
3. Coat the terminals with dielectric grease or petroleum jelly.
4. Secure the battery hold-down strap.
5. Connect and tighten the red (positive) cable first.
6. Connect and tighten the black (negative) cable last.
7. Verify that cables are properly routed.
8. Reinstall the seat.

## MAINTENANCE

### BATTERY MAINTENANCE AND CHARGING

#### WARNING

An overheated battery may explode, causing severe injury or death. Always watch charging times carefully. Stop charging if the battery becomes very warm to the touch. Allow it to cool before resuming charging.

The sealed battery is already filled with electrolyte and has been sealed and *fully charged* at the factory. *Never* pry the sealing strip off or add any other fluid to this battery.

The single most important thing about maintaining a sealed battery is to keep it fully charged. Check the battery voltage with a voltmeter or multimeter. A fully charged battery will register 12.8 V or higher. If the voltage falls below 12.5V, charge it immediately, or the battery runs the risk of sulfation and reduced battery life.

If you do not drive the vehicle for more than TWO WEEKS, Polaris recommends using a BatteryMINDER® 2012 AGM - 2 AMP charger (PN 2830438), which can be ordered through your dealer. During charging, place the charger outside of the vehicle and protect it from moisture.

Polaris provides a charging accessory<sup>②</sup> with your vehicle that allows easy connection to the battery through the 12V auxiliary outlet<sup>①</sup>, located on the dash. During charging, place the charger outside of the vehicle and protect it from moisture.

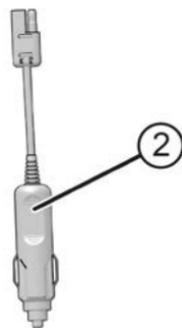
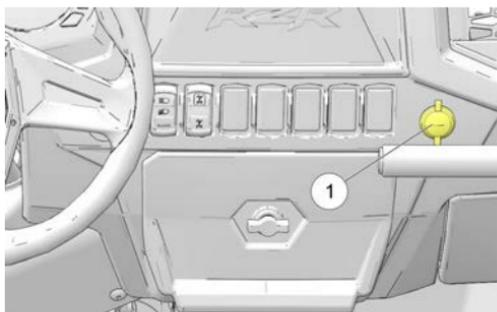

#### IMPORTANT

The 12V socket located in the rear of 4 seat vehicles is powered after key-on and **CANNOT** be used for charging.

If you plan to store the vehicle for ONE MONTH or longer, remove the battery from the vehicle, then store the battery in a cool and dry location. Continue to maintain the battery with the BatteryMINDER® 2012 AGM - 2 AMP charger.

When using an automatic charger other than a BatteryMINDER® 2012-AGM - 2 AMP charger, refer to the charger manufacturer's instructions for recharging.

If using a **constant current charger** (instead of BatteryMINDER® 2012 AGM - 2 AMP charger), use the guidelines below. Always verify battery condition before and 1-2 hours after the end of charging.

State of Charge	Voltage (DC)	Action	Charge Time*
100%	12.8-13.0 volts	None, check monthly	None required
75%-100%	12.6-12.8 volts	May need slight charge, if no charge given, check in 2 weeks	3-6 hours
50%-75%	12.3-12.6 volts	Needs charge	5-11 hours
25%-50%	12.0-12.3 volts	Needs charge	At least 13 hours
0%-25%	12.0 volts or less	Needs charge	At least 20 hours
* Using AGM specific charger at standard amps specified on top of battery			

# CLEANING AND STORAGE

## WASHING THE VEHICLE

Keeping your POLARIS vehicle clean will not only improve its appearance but it can also extend the life of various components.

### NOTICE

Water in the PVT system could cause the drive belt to become wet and slip in the clutches. When washing the vehicle, always avoid spraying water directly toward the PVT intake duct ①.

High water pressure may damage the radiator fins and impair the radiator's effectiveness. High pressure may also damage other vehicle components.

Certain products, including insect repellents and chemicals, will damage plastic surfaces. Do not allow these types of products to contact the vehicle.

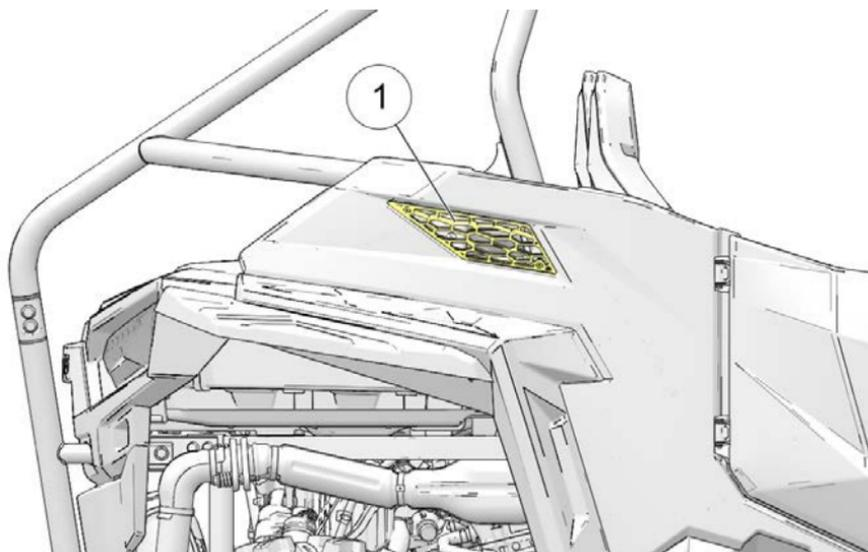

The best and safest way to clean your POLARIS vehicle is with a garden hose and a pail of mild soap and water.

1. Use a professional-type washing cloth, cleaning the upper body first and the lower parts last.
2. Rinse with clean water frequently.
3. Dry surfaces with a chamois to prevent water spots.

## WASHING TIPS

- Avoid the use of harsh cleaners, which can damage the finish.
- Do not use a power washer to clean the vehicle.
- Do not use medium to heavy duty compounds on the finish.
- Always use clean cloths and pads for cleaning and polishing. Old or reused cloths and pads may contain dirt particles that will scratch the finish.

If a high pressure water system is used for cleaning (not recommended), exercise extreme caution. The water may damage components and could remove paint and labels. Avoid directing the water stream at the following items:

- Wheel bearings
- Radiator
- Transmission seals
- Brakes
- Cab and body panels
- Labels and decals
- Electrical components and wiring
- Air intake components

If warning and safety labels are damaged, contact your POLARIS dealer for free replacement.

Grease all zerk fittings immediately after washing. Allow the engine to run for a while to evaporate any water that may have entered the engine or exhaust system.

## POLISHING THE VEHICLE

POLARIS recommends the use of common household aerosol furniture polish for polishing the finish on your POLARIS vehicle. Follow the instructions on the container.

## POLISHING TIPS

- Avoid the use of automotive products, some of which can scratch the finish of your vehicle.
- Always use clean cloths and pads for cleaning and polishing. Old or reused cloths and pads may contain dirt particles that will scratch the finish.

## STORAGE TIPS

### NOTICE

Starting the engine during the storage period will disturb the protective film created by fogging and damage could occur. Never start the engine during the storage period.

## MAINTENANCE

---

### ***CLEAN THE EXTERIOR***

Make any necessary repairs and clean the vehicle as recommended. See the Washing the Vehicle section for details.

### ***STABILIZE THE FUEL***

1. Fill the fuel tank.
2. Add POLARIS Carbon Clean Fuel Treatment or POLARIS Fuel Stabilizer or equivalent fuel treatments or stabilizers. Follow the instructions on the container for the recommended amount. Carbon Clean removes water from fuel systems, stabilizes fuel and removes carbon deposits from pistons, rings, valves and exhaust systems.
3. Allow the engine to run for 15-20 minutes to allow the stabilizer to disperse through the entire fuel delivery system.

### ***OIL AND FILTER***

Change the oil and filter. See the Oil and Filter Change section for details.

### ***AIR FILTER / AIR BOX***

Replace the air filter. See the Air Filter section for details. Clean the air box.

### ***FLUID LEVELS***

Inspect the fluid levels. Add or change fluids as recommended in the Periodic Maintenance Chart.

- Demand drive fluid (front gearcase)
- Rear gearcase fluid (if equipped)
- Transmission fluid
- Brake fluid (change every two years and any time the fluid looks dark or contaminated)
- Coolant (test strength/fill)

### ***INSPECT AND LUBRICATE***

Inspect all cables and lubricate all areas of the vehicle as recommended in the Periodic Maintenance Chart.

## FOG THE ENGINE

1. Treat the fuel system with POLARIS Carbon Clean or other equivalent fuel treatment. Follow the instructions on the container. Start the engine. Allow it to idle for several minutes so the Carbon Clean reaches the injectors. Stop the engine.
2. Remove the spark plugs and add 2-3 tablespoons of engine oil. To access the plug holes, use a section of clear 1/4 in (6.35 mm) hose and a small plastic squeeze bottle filled with the pre-measured amount of oil. *Do this carefully! If you miss the plug holes, oil will drain from the spark plug cavities into the hole at the front of the cylinder head, and appear to be an oil leak.*
3. Reinstall the spark plugs. Torque to specification. See the Spark Plug Gap / Torque section for details.
4. Apply dielectric grease to the inside of each spark plug cap. *Do not reinstall the caps onto the plugs at this step.*
5. Turn the engine over several times. Oil will be forced in and around the piston rings and ring lands, coating the cylinder with a protective film of fresh oil.
6. If POLARIS fuel system additive is not used, fuel tank, fuel lines, and injectors should be completely drained of gasoline.
7. Reinstall the spark plug caps to the spark plugs.

## BATTERY MAINTENANCE

See the Battery section for storage and charging procedures.

## STORAGE AREA / COVERS

Be sure the storage area is well ventilated. Cover the vehicle with a genuine POLARIS cover. Do not use plastic or coated materials. They do not allow enough ventilation to prevent condensation, and may promote corrosion and oxidation.

## REMOVAL FROM STORAGE



**WARNING**

Engine exhaust contains poisonous carbon monoxide and can cause loss of consciousness or death. Never run an engine in an enclosed area.

1. Charge the battery if necessary.
2. Make sure the spark plug is tight. Reinstall the fuse box cover if it was removed for storage.
3. Fill the fuel tank with fuel.

## MAINTENANCE

---

4. Check all the points listed in the Daily Pre-Ride Inspection section. Tightness of the bolts, nuts and other fasteners should be checked by an authorized POLARIS dealer or other qualified service facility.
5. Lubricate at the intervals outlined in the Periodic Maintenance Chart section.

## TRANSPORTING THE VEHICLE

Follow these procedures when transporting the vehicle.

1. Place the transmission in PARK. Stop the engine.
2. Slowly release the brake pedal and make sure the transmission is in PARK before exiting the vehicle
3. Remove the key to prevent loss during transporting.
4. Secure the fuel cap and seats. Ensure that the seats are attached correctly and are not loose.

### WARNING

Cargo and other loose vehicle parts may fly off while transporting this vehicle. Secure or remove all cargo, and inspect the unit for loose parts prior to transport.

If transporting the vehicle in a non-enclosed trailer, then the vehicle must FACE FORWARD, or roof must be removed.

Failure to comply may allow airflow, vibration, or other factors to separate the roof from the vehicle and cause an accident, resulting in serious personal injury or death.

5. Always tie the frame of the POLARIS vehicle to the transporting unit securely with suitable straps or rope. Do not attach tie straps to the front control arm bolt pockets.



① Two Front Tie-Down Points



② Two Rear Tie-Down Points (or tow loop)



## SPECIFICATIONS

## TRAIL 900 SPECIFICATIONS

TRAIL 900	
Gross Vehicle Weight	SPORT: 2062 lb (935 kg) PREMIUM: 2080 lb (943 kg) ULTIMATE: 2117 lb (960 kg)
Dry Weight Dry weight can also be found on the manufacture's statement of origin (MSO).	SPORT: 1238 lb (562 kg) PREMIUM: 1260 lb (572 kg) ULTIMATE: 1297 lb (588 kg)
Test GVW - Rollover Protection System (ROPS)	2300 lb (1043 kg) per OSHA® 29 CFR 1928.53
Rear Cargo Box Capacity	300 lb (136 kg)
Maximum Weight Capacity (Payload)	740 lb (336.4 kg) (riders, cargo, accessories, tongue weight)
Towing Capacity	1500 lb (682 kg)
Hitch Tongue Capacity	150 lb (68 kg)
Fuel Capacity	9.5 gal (36 L)
Engine Oil Capacity	2.5 qt (2.4 L)
Coolant Capacity	5 qt (4.7 L)
Demand Drive Fluid Capacity	7.5 fl oz (222 mL)
Transmission Oil Capacity	44 fl oz (1300 mL)
Overall Dimensions	107 in (271.8 cm) long, 50 in (127 cm) wide, 69.5 in (176.5 cm) high
Wheelbase	79 in (200 cm)
Ground Clearance	10 in (25.4 cm)
Engine	4-Stroke DOHC Twin Cylinder
Displacement	875 cc
Bore x Stroke	93 mm x 64.4 mm

## SPECIFICATIONS

<b>TRAIL 900</b>	
Alternator Output	560 W @ 3000 RPM
Compression Ratio	10.5:1
Starting System	Electric
Fuel System	Electronic fuel injection
Ignition System	Electronic
Spark Plug / Gap	NGK® MR7F / 0.028-0.031 in (0.7-0.8 mm)
Front Suspension	Independent double a-arm with 10 in (25.4 cm) of travel
Rear Suspension	Independent double a-arm with 10 in (25.4 cm) of travel
Lubrication System	Wet Sump
Driving System Type	Automatic POLARIS Variable Transmission EPS: Lockable Differential
Shift Type	Dual Range P/R/N/L/H
Tires / Tire Pressure - Front	26x8-12 / 10 psi (69 kPa)
Tires / Tire Pressure - Rear	26x9-12 / 12 psi (83 kPa)
Brakes, Front/Rear	Foot Activated, 4-wheel hydraulic disc
Headlights	2 Dual Beam Halogen or LED
Taillights	2 LED cluster
Brake Lights	2 LED cluster
Instrument Cluster	Analog and LCD
Auxiliary DC Outlet	12V

## OUTPUT GEAR RATIOS

OUTPUT GEAR RATIOS		
<b>Rear</b>		
High Gear	10.73	
Low Gear	18.77	
Reverse	20.41	
<b>Front (including front drive)</b>		
	<b>Non-EPS</b>	<b>EPS</b>
High Gear	13.71	11.88
Low Gear	23.94	20.74
Reverse	26.07	22.59
Drive Ratio - Front	3.82	3.31

## CLUTCHING

Please see your authorized dealer for clutching specifications

## SPECIFICATIONS

### TRAIL S 900 SPECIFICATIONS

TRAIL S 900	
Gross Vehicle Weight	2103 lb (954 kg)
Dry Weight Dry weight can also be found on the manufacture's statement of origin (MSO).	1283 lb (582 kg)
Test GVW - Rollover Protection System (ROPS)	2300 lb (1043 kg) per OSHA® 29 CFR 1928.53
Rear Cargo Box Capacity	300 lb (136 kg)
Maximum Weight Capacity (Payload)	740 lb (336.4 kg) (riders, cargo, accessories, tongue weight)
Towing Capacity	1500 lb (682 kg)
Hitch Tongue Capacity	150 lb (68 kg)
Fuel Capacity	9.5 gal (36 L)
Engine Oil Capacity	2.5 qt (2.4 L)
Coolant Capacity	5 qt (4.7 L)
Demand Drive Fluid Capacity	7.5 fl oz (222 mL)
Transmission Oil Capacity	44 fl oz (1300 mL)
Overall Dimensions	108 in (274.3 cm) long, 60 in (152.4) wide, 72 in (182.9 cm) high
Wheelbase	79 in (200 cm)
Ground Clearance	12.5 in (31.75 cm)
Engine	4-Stroke DOHC Twin Cylinder
Displacement	875 cc
Bore x Stroke	93 mm x 64.4 mm
Alternator Output	560 W @ 3000 RPM
Compression Ratio	10.5:1

## SPECIFICATIONS

<b>TRAIL S 900</b>	
Starting System	Electric
Fuel System	Electronic fuel injection
Ignition System	Electronic
Spark Plug / Gap	NGK® MR7F / 0.028-0.031 in (0.7-0.8 mm)
Front Suspension	Independent double a-arm with 12.25 in (31.1 cm) of travel
Rear Suspension	Independent double a-arm with 13.2 in (33.5 cm) of travel
Lubrication System	Wet Sump
Driving System Type	Automatic POLARIS Variable Transmission EPS: Lockable Differential
Shift Type	Dual Range P/R/N/L/H
Tires / Tire Pressure - Front	27x9-12 / 10 psi (69 kPa)
Tires / Tire Pressure - Rear	27x11-12 / 14 psi (97 kPa)
Brakes, Front/Rear	Foot Activated, 4-wheel hydraulic disc
Headlights	2 Dual Beam Halogen or LED
Taillights	2 LED cluster
Brake Lights	2 LED cluster
Instrument Cluster	Analog and LCD
Auxiliary DC Outlet	12V

## SPECIFICATIONS

---

### OUTPUT GEAR RATIOS

OUTPUT GEAR RATIOS		
<b>Rear</b>		
High Gear	10.73	
Low Gear	18.77	
Reverse	20.41	
<b>Front (including front drive)</b>		
	<b>Non-EPS</b>	<b>EPS</b>
High Gear	13.71	11.88
Low Gear	23.94	20.74
Reverse	26.07	22.59
Drive Ratio - Front	3.82	3.31

### CLUTCHING

Please see your authorized dealer for clutching specifications

# POLARIS PRODUCTS

## LUBRICANTS / SERVICE PRODUCTS

PART NUMBER	DESCRIPTION
<b>Engine Lubricant</b>	
2870791	Fogging Oil — 12 fl oz (355 mL) Aerosol
2876244	PS-4 Full Synthetic 5W-50 4-Cycle Oil — 1 qt (0.95 L)
2876245	PS-4 Full Synthetic 5W-50 4-Cycle Oil — 1 gal (3.8 L)
2878920	PS-4 Extreme Duty Synthetic 10W-50 4-Cycle Oil — 1 qt (0.95 L)
2878919	PS-4 Extreme Duty Synthetic 10W-50 4-Cycle Oil — 1 gal (3.8 L)
<b>Gearcase / Transmission Lubricants</b>	
2878068	AGL Full Synthetic Gearcase Lubricant & Transmission Fluid — 1 qt (0.95 L)
2878069	AGL Full Synthetic Gearcase Lubricant & Transmission Fluid — 1 gal (3.8 L)
2877922	Demand Drive Fluid — 1 qt (0.95 L)
2877923	Demand Drive Fluid — 1 gal (3.8 L)
2870465	Pump for 1 gal (3.8 L) Jug
<b>Coolant</b>	
2880514	Antifreeze 50/50 Premix — 1 qt (0.95 L)
2880513	Antifreeze 50/50 Premix — 1 gal (3.8 L)
<b>Grease / Specialized Lubricants</b>	
2871312	Grease Gun Kit, All Season Grease
2871322	All Season Grease — 3 fl oz (89 mL) Cartridge
2871423	All Season Grease — 14 fl oz (414 mL) Cartridge
2876160	ATV Angle Drive Fluid — 1 qt (0.95 L)

## POLARIS PRODUCTS

<b>PART NUMBER</b>	<b>DESCRIPTION</b>
2872276	ATV Angle Drive Fluid — 2.5 gal (9.5 L)
2871460	Premium Starter Grease
2871515	U-Joint Grease — 3 fl oz (89 mL) Cartridge
2871551	U-Joint Grease — 14 fl oz (414 mL) Cartridge
2871329	Dielectric Grease (Nyogel®)
<b>Additives / Miscellaneous</b>	
2871326	Carbon Clean
2870652	Fuel Stabilizer
2872189	DOT 4 Brake Fluid
2871956	Loctite® 565 Thread Sealant
2859044	POLARIS Battery Tender Charger

## TROUBLESHOOTING

### DRIVE BELT WEAR / BURN

POSSIBLE CAUSE	SOLUTION
Driving onto a pickup or tall trailer in high range	Use low range during loading.
Starting out going up a steep incline	Use low range. See the Low Range section for details.
Driving at low RPM or ground speed 3-7 mph (5-11 km/h)	Drive at a higher speed or use low range more frequently. See the Low Range section for details.
Insufficient warm-up at low ambient temperatures	Warm the engine at least 5 minutes. With the transmission in neutral, advance the throttle to about 1/8 throttle in short bursts, 5 to 7 times. The belt will become more flexible and prevent belt burning.
Slow/easy clutch engagement	Use the throttle quickly and effectively.
Hauling heavy cargo/ pushing at low RPM/low ground speed	Use low range only.
Utility use/plowing	Use low range only.
Stuck in mud or snow	Shift the transmission to low range and carefully use fast, aggressive throttle application to engage clutch. <b>WARNING!</b> Excessive throttle may cause loss of control and vehicle rollover.
Climbing over large objects from a stopped position	Shift the transmission to low range and carefully use fast, brief, aggressive throttle application to engage clutch. <b>WARNING!</b> Excessive throttle may cause loss of control and vehicle rollover.
Belt slippage from water or snow ingestion into the PVT system	Dry out the PVT. Prevent water from entering the PVT outlet duct (see the Washing the Vehicle section for details). Inspect clutch seals for damage if repeated leaking occurs.
Clutch malfunction	See your dealer.

## TROUBLESHOOTING

POSSIBLE CAUSE	SOLUTION
Poor engine performance	Check for fouled plugs or foreign material in gas tank or fuel lines. See your dealer.
Slippage from failure to warm up belt	Always warm up the belt by operating below 30 mph (48 km/h) for 1 miles (1.5 km) and for 5 miles (8 km) or more when temperature is below freezing.
Wrong or missing belt	Install the recommended belt.
Improper break-in	Always break in a new belt and/or clutch. See the Vehicle Break-in Period section for details.
Failed belt	Remove the belt and clean away any debris from the clutch box, clutch duct and engine compartment. Install a new belt. <b>WARNING!</b> Failure to remove ALL debris when replacing the belt could result in vehicle damage and severe injury or death. See the Belt Replacement / Debris Removal section for details.

## ENGINE DOESN'T TURN OVER

POSSIBLE CAUSE	SOLUTION
Low battery voltage	Recharge the battery to 12.8 VDC
Loose battery connections	Check all connections and tighten
Loose solenoid connections	Check all connections and tighten
Loose electronic control box connections	Inspect, clean, reinstall connectors; blow on EFI fuse to remove impurities
Mechanical failure	Your POLARIS dealer or other qualified person can assist.

**ENGINE TURNS OVER, FAILS TO START**

<b>POSSIBLE CAUSE</b>	<b>SOLUTION</b>
Out of fuel	Refuel
Clogged fuel filter	Your POLARIS dealer or other qualified person can assist.
Water is present in fuel	Drain the fuel system and refuel
Old or non-recommended fuel	Replace with fresh recommended fuel
Fouled or defective spark plugs	Inspect plugs and replace if necessary
No spark to spark plug	Inspect plugs and replace if necessary
Water or fuel in crankcase	Your POLARIS dealer or other qualified person can assist.
Low battery voltage	Recharge the battery to 12.8 VDC
Loose ignition connections	Check all connections and tighten
Mechanical failure	Your POLARIS dealer or other qualified person can assist.

**ENGINE BACKFIRES**

<b>POSSIBLE CAUSE</b>	<b>SOLUTION</b>
Out of fuel	Refuel
Weak spark from spark plug	Inspect, clean and/or replace spark plugs
Incorrect spark plug gap or heat range	Set gap to specs or replace plugs
Old or non-recommended fuel	Replace with fresh recommended fuel
Incorrectly installed spark plug wires	Your POLARIS dealer or other qualified person can assist.

## TROUBLESHOOTING

<b>POSSIBLE CAUSE</b>	<b>SOLUTION</b>
Incorrect ignition timing	Your POLARIS dealer or other qualified person can assist.
Loose ignition connections	Check all connections and tighten
Water present in fuel	Replace with fresh recommended fuel
Exhaust leak	Check all connections
Mechanical failure	Your POLARIS dealer or other qualified person can assist.

---

**ENGINE PINGS OR KNOCKS**

<b>POSSIBLE CAUSE</b>	<b>SOLUTION</b>
Poor quality or low octane fuel	Replace with recommended fuel
Incorrect ignition timing	Your POLARIS dealer or other qualified person can assist.
Incorrect spark plug gap or heat range	Set gap to specs or replace plugs

## TROUBLESHOOTING

### ENGINE RUNS IRREGULARLY, STALLS, OR MISFIRES

POSSIBLE CAUSE	SOLUTION
Fouled or defective spark plugs	Inspect, clean and/or replace spark plugs
Worn or defective spark plug wires	Your POLARIS dealer or qualified person can assist
Incorrect spark plug gap or heat range	Set gap to specs or replace plugs
Loose ignition connections	Check all connections and tighten
Water present in fuel	Replace with new fuel
Low battery voltage	Recharge battery to 12.8 VDC
Kinked or plugged fuel tank vent line or filter	Inspect and replace
Kinked idle air control lines	Inspect; rotate lines to remove kink
Incorrect fuel	Replace with recommended fuel
Clogged air filter	Inspect and replace
Clogged intake pre-filter	Inspect and clean (with soapy water) or replace
Other mechanical failure	See your dealer

POSSIBLE LEAN FUEL CAUSE	SOLUTION
Low or contaminated fuel	Add or change fuel, clean the fuel system
Low octane fuel	Replace with recommended fuel
Clogged fuel filter	See your dealer
Low fuel pressure	See your dealer

**ENGINE STOPS OR LOSES POWER**

<b>POSSIBLE CAUSE</b>	<b>SOLUTION</b>
Out of fuel	Refuel
Kinked or plugged fuel tank vent line or filter	Inspect and replace
Water is present in fuel	Replace with new fuel
Fouled or defective spark plugs	Inspect, clean and/or replace spark plug
Worn or defective spark plug wires	See your dealer
Incorrect spark plug gap or heat range	Set gap to specs or replace plug
Loose ignition connections	Check all connections and tighten
Low battery voltage	Recharge the battery to 12.8 VDC
Incorrect fuel	Replace with fresh recommended fuel
Clogged air filter	Inspect and replace
Clogged intake pre-filter	Inspect and clean (with soapy water) or replace
Other mechanical failure	See your dealer
Overheated engine	Clean radiator screen and core, clean engine exterior, check coolant level, see your dealer if condition persists



## WARRANTY

### LIMITED WARRANTY

POLARIS Industries Inc., 2100 Highway 55, Medina, MN 55340 (POLARIS) gives a SIX MONTH LIMITED WARRANTY on all components of your POLARIS vehicle against defects in material or workmanship. POLARIS further warrants that the spark arrester in this product will meet the efficiency requirements of USFS standard 5100-1C for at least 1000 hours when subjected to normal use and when maintenance and installation are in accordance with POLARIS recommendations.

This warranty covers parts and labor charges for repair or replacement of defective parts and begins on the date of purchase by the original retail purchaser. This warranty is transferable to another owner during the warranty period through a POLARIS dealer, but any such transfer will not extend the original term of the warranty. The duration of this warranty may vary by international region based upon local laws and regulations.

### REGISTRATION

At the time of sale, the Warranty Registration Form must be completed by your dealer and submitted to POLARIS within ten days of purchase. Upon receipt of this registration, POLARIS will record the registration for warranty. No verification of registration will be sent to the purchaser as the copy of the Warranty Registration Form will be your proof of warranty coverage. If you have not signed the original registration and received the customer copy, please contact your dealer immediately. **NO WARRANTY COVERAGE WILL BE ALLOWED UNLESS YOUR VEHICLE IS REGISTERED WITH POLARIS.** Initial dealer preparation and set-up of your vehicle is very important in ensuring trouble-free operation. Purchasing a machine in the crate or without proper dealer set-up will void your warranty coverage.

# WARRANTY COVERAGE AND EXCLUSIONS

## LIMITATIONS OF WARRANTIES AND REMEDIES

This POLARIS limited warranty excludes any failures that are not caused by a defect in material or workmanship. THIS WARRANTY DOES NOT COVER CLAIMS OF DEFECTIVE DESIGN. This warranty also does not cover acts of God, accidental damage, normal wear and tear, abuse or improper handling. This warranty also does not cover any vehicle, component, or part that has been altered structurally, modified, neglected, improperly maintained or used for racing, competition or purposes other than for which it was designed.

This warranty excludes damages or failures resulting from improper lubrication; improper engine timing; improper fuel; surface imperfections caused by external stress, heat, cold or contamination; operator error or abuse; improper component alignment, tension, adjustment or altitude compensation; snow, water, dirt or other foreign substance ingestion/contamination; improper maintenance; modified components; use of aftermarket or unapproved components, accessories, or attachments; unauthorized repairs; or repairs made after the warranty period expires or by an unauthorized repair center.

This warranty excludes damages or failures caused by abuse, accident, fire, or any other cause other than a defect in materials or workmanship and provides no coverage for consumable components, general wear items, or any parts exposed to friction surfaces, stresses, environmental conditions and/or contamination for which they were not designed or not intended, including but not limited to the following items:

- Wheels and tires
- Suspension components
- Brake components
- Seat components
- Clutches and components
- Steering components
- Batteries
- Light bulbs/Sealed beam lamps
- Filters
- Lubricants
- Bushings
- Finished and unfinished surfaces
- Carburetor/Throttle body components
- Engine components
- Drive belts
- Hydraulic components and fluids
- Circuit breakers/Fuses
- Electronic components
- Spark plugs
- Sealants
- Coolants
- Bearings

## LUBRICANTS AND FLUIDS

1. Mixing oil brands or using non-recommended oil may cause engine damage. We recommend the use of POLARIS engine oil.
2. Damage or failure resulting from the use of non-recommended lubricants or fluids is not covered by this warranty.

This warranty provides no coverage for personal loss or expense, including mileage, transportation costs, hotels, meals, shipping or handling fees, product pick-up or delivery, replacement rentals, loss of product use, loss of profits, or loss of vacation or personal time.

THE EXCLUSIVE REMEDY FOR BREACH OF THIS WARRANTY SHALL BE, AT POLARIS' OPTION, REPAIR OR REPLACEMENT OF ANY DEFECTIVE MATERIALS, COMPONENTS, OR PRODUCTS. THE REMEDIES SET FORTH IN THIS WARRANTY ARE THE ONLY REMEDIES AVAILABLE TO ANY PERSON FOR BREACH OF THIS WARRANTY. POLARIS SHALL HAVE NO LIABILITY TO ANY PERSON FOR INCIDENTAL, CONSEQUENTIAL OR SPECIAL DAMAGES OF ANY DESCRIPTION, WHETHER ARISING OUT OF EXPRESS OR IMPLIED WARRANTY OR ANY OTHER CONTRACT, NEGLIGENCE, OR OTHER TORT OR OTHERWISE. THIS EXCLUSION OF CONSEQUENTIAL, INCIDENTAL, AND SPECIAL DAMAGES IS INDEPENDENT FROM AND SHALL SURVIVE ANY FINDING THAT THE EXCLUSIVE REMEDY FAILED OF ITS ESSENTIAL PURPOSE.

THE IMPLIED WARRANTY OF FITNESS FOR A PARTICULAR PURPOSE IS EXCLUDED FROM THIS LIMITED WARRANTY. ALL OTHER IMPLIED WARRANTIES (INCLUDING BUT NOT LIMITED TO THE IMPLIED WARRANTY OF MERCHANTABILITY) ARE LIMITED IN DURATION TO THE ABOVE SIX MONTH WARRANTY PERIOD. POLARIS DISCLAIMS ALL EXPRESS WARRANTIES NOT STATED IN THIS WARRANTY. SOME STATES DO NOT PERMIT THE EXCLUSION OR LIMITATION OF INCIDENTAL OR CONSEQUENTIAL DAMAGES OR ALLOW LIMITATIONS ON THE DURATION OF IMPLIED WARRANTIES, SO THE ABOVE LIMITATIONS MAY NOT APPLY TO YOU IF INCONSISTENT WITH CONTROLLING STATE LAW.

### HOW TO OBTAIN WARRANTY SERVICE

If your vehicle requires warranty service, you must take it to a POLARIS Servicing Dealer. When requesting warranty service you must present your copy of the Warranty Registration Form to the dealer. (THE COST OF TRANSPORTATION TO AND FROM THE DEALER IS YOUR RESPONSIBILITY.) POLARIS suggests that you use your original selling dealer; however, you may use any POLARIS Servicing Dealer to perform warranty service.

***In the Country where your product was purchased:***

Warranty or Service Bulletin repairs must be done by an authorized POLARIS dealer. If you move or are traveling within the country where your product was purchased, Warranty and Service Bulletin repairs may be requested from any authorized POLARIS dealer that sells the same line as your product.

***Outside the Country where your product was purchased:***

If you are traveling temporarily outside the country where your product was purchased, you should take your product to an authorized POLARIS dealer. You must show the dealer photo identification from the country of the selling dealer's authorized location as proof of residence. Upon residence verification, the servicing dealer will be authorized to perform the warranty repair.

***If you move:***

If you move to another country, be sure to contact POLARIS Customer Assistance and the customs department of the destination country before you move. Product importation rules vary considerably from country to country. You may be required to present documentation of your move to POLARIS in order to continue your warranty coverage. You may also be required to obtain documentation from POLARIS in order to register your product in your new country. You should warranty register your product at a local POLARIS dealer in your new country immediately after you move to continue your warranty coverage and to ensure that you receive information and notices regarding your vehicle.

***If you purchase from a private party:***

If you purchase a POLARIS product from a private party, to be kept and used outside of the country in which the product was originally purchased, all warranty coverage will be denied. You must nonetheless register your product under your name and address with a local POLARIS dealer in your country to ensure that you receive safety information and notices regarding your product.

## EXPORTED PRODUCTS

EXCEPT WHERE SPECIFICALLY REQUIRED BY LAW, THERE IS NO WARRANTY OR SERVICE BULLETIN COVERAGE ON THIS PRODUCT IF IT IS SOLD OUTSIDE THE COUNTRY OF THE SELLING DEALER'S AUTHORIZED LOCATION. This policy does not apply to products that have received authorization for export from POLARIS. Dealers may not give authorization for export. You should consult an authorized dealer to determine this product's warranty or service coverage if you have any questions. This policy does not apply to products registered to government officials or military personnel on assignment outside the country of the selling dealer's authorized location. This policy does not apply to Safety Bulletins.

## NOTICE

If your product is registered outside of the country where it was purchased and you have not followed the procedure set above, your product will no longer be eligible for warranty or service bulletin coverage of any kind, other than safety bulletins. Products registered to government officials or military personnel on assignment outside of the country where the product was purchased will continue to be covered by the Limited Warranty.

Please work with your dealer to resolve any warranty issues. Dealership contacts can be found via this website, if needed:

**[www.polaris.com/en-us/contact](http://www.polaris.com/en-us/contact)**

Should your dealer require any additional assistance, they will contact the appropriate person at POLARIS.

This warranty gives you specific legal rights, and you may also have other rights which vary from state to state or in different countries. If any of the above terms are void because of federal, state, local law, all other warranty terms will remain in effect.

### ***For questions call POLARIS Owner Connections:***

United States & Canada: 1-800-POLARIS (1-800-765-2747)

French: 1-800-268-6334

To report a safety defect to Transport Canada, you may either fill out an online defect complaint form at their website:

English: <http://www.tc.gc.ca/recalls>

French: <http://www.tc.gc.ca/rappels>

Or contact their Defect Investigations and Recalls Division by calling toll-free 1-800-333-0510 (Canada) or 819-994-3328 (Ottawa-Gatineau area / International).

## WARRANTY

---

### **U.S.A. EPA EMISSIONS LIMITED WARRANTY**

This emissions limited warranty is in addition to the POLARIS standard limited warranty for your vehicle. POLARIS Industries Inc. warrants that at the time it is first purchased, this emissions-certified vehicle is designed, built and equipped so it conforms with applicable U.S. Environmental Protection Agency emission regulations. POLARIS warrants that the vehicle is free from defects in materials and workmanship that would cause it to fail to meet these regulations.

The warranty period for off road vehicles 100cc or greater emissions-certified vehicles starts on the date of purchase by original retail purchaser and continues for a period of 500 hours of engine operation, 3100 miles (5000 km) of vehicle travel, or 30 calendar months from the date of purchase, whichever comes first. The warranty period for ATVs less than 100cc emissions-certified vehicles starts on the date of purchase by original retail purchaser and continues for a period of 250 hours of engine operation, 1550 miles (2500 km) of vehicle travel, or 30 calendar months from the date of purchase, whichever comes first. This EPA emissions warranty period is extended for at least as long as the standard factory warranty that Polaris provides on the vehicle as a whole. The EPA emissions warranty period does not further extend if you purchase additional warranty coverage in the form of a service contract or other paid warranty extension, but emission-related parts may be covered subject to the terms of any such paid service contract or paid warranty extension.

This emissions limited warranty covers components whose failure increases the vehicle's regulated emissions, and it covers components of systems whose only purpose is to control emissions. Repairing or replacing other components not covered by this warranty is the responsibility of the vehicle owner. This emissions limited warranty does not cover components whose failure does not increase the vehicle's regulated emissions.

For exhaust emissions, emission-related components include any engine parts related to the following systems:

- Air-induction system
- Fuel System
- Ignition system
- Exhaust gas recirculation systems

The following parts are also considered emission-related components for exhaust emissions:

- After treatment devices
- Crankcase ventilation valves
- Sensors
- Electronic control units

The following parts are considered emission-related components for evaporative emissions:

- Fuel Tank
- Fuel Cap
- Fuel Line
- Fuel Line Fittings
- Clamps\*
- Pressure Relief Valves\*
- Control Valves\*
- Control Solenoids\*
- Electronic Controls
- Vacuum Control Diaphragms\*
- Control Cables\*
- Control Linkages\*
- Purge Valves
- Vapor Hoses
- Liquid/Vapor Separator
- Carbon Canister
- Canister Mounting Brackets
- Carburetor Purge Port Connector

\*As related to the evaporative emission control system.

Emission-related components also include any other part whose only purpose is to reduce emissions or whose failure will increase emissions without significantly degrading engine/equipment performance. The exclusive remedy for breach of this limited warranty shall be, at the exclusive option of POLARIS, repair or replacement of any defective materials, components or products. THE REMEDIES SET FORTH IN THIS LIMITED WARRANTY ARE THE ONLY REMEDIES AVAILABLE TO ANY PERSON FOR BREACH OF THIS WARRANTY. POLARIS SHALL HAVE NO LIABILITY TO ANY PERSON FOR INCIDENTAL, CONSEQUENTIAL OR SPECIAL DAMAGES OF ANY DESCRIPTION, WHETHER ARISING OUT OF EXPRESS OR IMPLIED WARRANTY OR ANY OTHER CONTRACT, NEGLIGENCE OR OTHER TORT OR OTHERWISE. THIS EXCLUSION OF CONSEQUENTIAL, INCIDENTAL, AND SPECIAL DAMAGES IS INDEPENDENT FROM AND SHALL SURVIVE ANY FINDING THAT THE EXCLUSIVE REMEDY FAILED OF ITS ESSENTIAL PURPOSE.

ALL IMPLIED WARRANTIES (INCLUDING BUT NOT LIMITED TO ANY IMPLIED WARRANTIES OF MERCHANTABILITY AND FITNESS FOR A PARTICULAR PURPOSE) ARE LIMITED IN DURATION TO THE WARRANTY PERIOD DESCRIBED HEREIN. POLARIS DISCLAIMS ALL EXPRESS WARRANTIES NOT STATED IN THIS WARRANTY. Some states do not allow limitations on how long an implied warranty lasts, so the above limitation may not apply if it is inconsistent with the controlling state law.

This limited warranty excludes failures not caused by a defect in material or workmanship. This limited warranty does not cover damage due to accidents, abuse or improper handling, maintenance or use. This limited warranty also does not cover any engine that has been structurally altered, or when the vehicle has been used in racing competition. This limited warranty also does not cover physical damage, corrosion or defects caused by fire, explosions or other similar causes beyond the control of POLARIS.

## WARRANTY

---

Owners are responsible for performing the scheduled maintenance identified in the owner's manual. POLARIS may deny warranty claims for failures that have been caused by the owner's or operator's improper maintenance or use, by accidents for which POLARIS has no responsibility, or by acts of God.

Any qualified repair shop or person may maintain, replace, or repair the emission control devices or systems on your vehicle. An authorized POLARIS dealer can perform any service that may be necessary for your vehicle. POLARIS also recommends POLARIS parts, however equivalent parts may be used for such service. It is a potential violation of the Clean Air Act if a part supplied by an aftermarket parts manufacturer reduces the effectiveness of the vehicle's emission controls. Tampering with emission controls is prohibited by federal law.

## CALIFORNIA RESIDENTS

Certain POLARIS Off-Road Vehicles are available in 49-state and 50-state versions. Only the 50-state models are certified for sale in California. The 50-state models available for sale in California are identified by the letter "B" in the ninth position of the model number (e.g., R16RTE87B). The POLARIS 50-state models are designed and built with features such as a reduced cargo box capacity. Any modifications to these features may be a violation of the applicable California regulations and may void this limited emissions warranty offered by the manufacturer.

The California evaporative emissions control system limited warranty statement below applies to your Off Highway Recreational Vehicle in California if the vehicle is equipped with an evaporative emission control system and is labeled with a Vehicle Evaporative Emissions Control Information label indicating that the vehicle conforms to California evaporative emissions regulations applicable to new off-road sport vehicles, all-terrain vehicles, or off-road utility vehicles. These vehicles are referred to as "OHRV-EVAP" below.

### **CALIFORNIA EMISSION CONTROL WARRANTY STATEMENT YOUR WARRANTY RIGHTS AND OBLIGATIONS**

The California Air Resources Board and Polaris Inc. are pleased to explain the emission control system warranty on your model year 2018 and newer Off Highway Recreational Vehicle. In California, new off-highway recreational vehicles must be designed, built and equipped to meet the State's stringent anti-smog standards. Polaris must warrant the emission control system on your OHRV-EVAP for the periods of time listed below provided there has been no abuse, neglect or improper maintenance of your OHRV-EVAP.

Your emission control system may include parts such as the carburetor or fuel injection system, fuel tank, fuel hoses, carbon canister, engine computer and Evaporative Emissions Control System parts listed in the U.S.A. EPA Emissions Limited Warranty. Also included may be hoses, belts, connectors and other emission-related assemblies. Where a warrantable condition exists, Polaris will repair your OHRV-EVAP at no cost to you including diagnosis, parts and labor.

#### **MANUFACTURER'S WARRANTY COVERAGE:**

For model year 2018 and newer OHRV-EVAP models.

For 30 months, or 2500 miles (4023 km), or 250 hours, whichever comes first, except for evaporative components over the OHRV high-priced warranty value, which is covered for 60 months, or 5000 miles (8047 km), or 500 hours, whichever comes first.

If any emission-related part on your OHRV-EVAP is defective, the part will be repaired or replaced by Polaris.

## WARRANTY

---

### OWNER'S WARRANTY RESPONSIBILITIES:

As the OHRV-EVAP owner, you are responsible for the performance of the required maintenance listed in your owner's manual. Polaris recommends that you retain all receipts covering maintenance on your OHRV-EVAP, but Polaris cannot deny warranty solely for the lack of receipts or for your failure to ensure the performance of a scheduled maintenance.

As an owner you are responsible for presenting your OHRV-EVAP to a Polaris dealer as soon as a problem exists. The warranty repairs should be completed in a reasonable amount of time, not to exceed 30 days.

As an OHRV-EVAP owner, you should also be aware that Polaris may deny you warranty coverage if your OHRV-EVAP or a part has failed due to abuse, neglect, improper maintenance or unapproved modifications.

### ADD-ON OR MODIFIED PARTS

An add-on or modified part must be compliant with applicable CARB emission control standards. A violation of this requirement is punishable by civil and/or criminal punishment.

If you have any questions regarding your warranty rights and responsibilities, you should contact Polaris Customer Assistance at 1-800-POLARIS (1-800-765-2747) or the California Air Resources Board at 9528 Telstar Avenue, El Monte, CA 91731.

United States & Canada: 1-800-POLARIS (1-800-765-2747)

French: 1-800-268-6334





---

3-Point Seat Belt ..... 40

## A

Adding or Changing Coolant ..... 154  
Air Box and Intake Duct  
  Cautions ..... 15  
Air Filter..... 161  
All Wheel Drive (AWD) Switch ..... 31  
All Wheel Drive (AWD) System ..... 43  
Auxiliary Outlets ..... 32  
Axle and Wheel Nut Torque  
  Specifications..... 173

## B

Battery ..... 179  
Battery Charging ..... 180  
Battery Installation ..... 179  
Battery Removal..... 179  
Before You Ride ..... 45  
Belt Debris Warning ..... 14  
Belt Replacement / Debris  
  Removal ..... 158  
Boots ..... 11  
Brake and Throttle Pedals ..... 36  
Brake Fluid..... 166  
Brake Inspection ..... 165  
Brakes ..... 164  
Braking ..... 85

## C

Cab Doors ..... 19, 34  
California Residents ..... 213  
Carrying Multiple Passengers  
  (4-Seat) ..... 20  
Carrying Multiple Passengers  
  (RZR 2-Seat)..... 19  
Check Engine Indicator ..... 64  
Clothing..... 11  
Clutching ..... 191, 194  
Component Locations..... 29  
Coolant  
  Adding or Changing ..... 154

Cooling System..... 154  
Crankcase Emission Control  
  System ..... 111  
Crossing Hillside..... 22

## D

Demand Drive Fluid Check ..... 147  
Demand Drive Unit (Front  
  Gearcase) ..... 147  
Descending Hills Improperly ..... 22  
Diagnostic Display Code  
  Definitions ..... 65  
Disengaging AWD ..... 44  
Display Units, Standard/Metric ..... 62  
Drive Belt Wear / Burn ..... 197  
Drive Responsibly Warning..... 14  
Driving Downhill ..... 90  
Driving in Reverse ..... 94  
Driving on a Sidehill (Sidehilling) ... 89  
Driving on Slippery Surfaces ..... 92  
Driving Over Obstacles ..... 93  
Driving Through Water..... 91  
Driving Uphill ..... 88  
Driving With Passengers ..... 87

## E

Electromagnetic Interference ..... 111  
Electronic Power Steering (EPS)... 32  
Engaging AWD ..... 43  
Engine Backfires ..... 199  
Engine Doesn't Turn Over ..... 198  
Engine Pings or Knocks ..... 201  
Engine Runs Irregularly, Stalls,  
  or Misfires ..... 202  
Engine Stops or Loses Power .... 203  
Engine Turns Over, Fails to  
  Start..... 199  
Equipment Modifications ..... 27  
Error Codes, Engine..... 64  
Exhaust Emission Control  
  System ..... 111  
Exported Products ..... 209  
Exposure to Exhaust ..... 25  
Eye Protection ..... 11

---

**F**

Failure to Inspect Before Operating .....	18
Fluid Change .....	146, 148
Fluid Check .....	145
FOX® Shock Compression Adjustment .....	169
FOX® Shocks .....	168
Fuel Cap .....	34
Fuel Transport Warning .....	13
Fuse / Relay Center .....	152

**G**

Gear Selector .....	37
Gearcase Specification Chart .....	149
Gloves .....	11

**H**

Hauling Cargo .....	96
Headlight Beam Adjustment .....	176
Headlight Replacement .....	175
Headlight Switch .....	32
Helmet .....	11
Hood .....	34
Hot Exhaust Systems .....	26
How To Obtain Warranty Service .....	208

**I**

Ignition Switch .....	31
Improper Cargo Loading .....	26
Improper Hill Climbing .....	22
Improper Tire Maintenance .....	23
Indicator Lamps .....	57
Instrument Cluster .....	55

**J**

Jumps and Stunts .....	22
------------------------	----

**K**

Know Your Riding Area / Tread Lightly® .....	86
--	----

**L**

Lights .....	175
Limited Warranty .....	205
Load / Passenger / Tire Pressure Warning .....	16
Locking/Unlocking the Differential (if equipped) .....	44
Lubrication Recommendations ...	139

**M**

Maintenance Intervals .....	114
Maintenance Log .....	215
Metric Display .....	62
Mode Button .....	56

**N**

New Operator Driving Procedures .....	86
Noise Emission Control System ...	111
Notice .....	209

**O**

Oil and Filter Change .....	143
Oil Check .....	142
Oil Recommendations .....	141
Operating on Pavement .....	21
with a Load on the Vehicle .....	20
Operating a Damaged Vehicle .....	25
Operating at Excessive Speeds ...	21
Operating Improperly in Reverse ...	23
Operating in Unfamiliar Terrain ...	23
Operating on Frozen Bodies of Water .....	25
Operating on Public Roads .....	21
Operating Over Obstacles .....	24

Operating Through Water .....	24
Operation on Public Lands in the U.S.A.....	111
Operator Restrictions/ Age Restrictions .....	18
Output Gear Ratios .....	191, 194
Overflow Bottle Coolant Level ....	156

## P

Parking on an Incline .....	95
Parking the Vehicle .....	85
Passenger Hand Hold .....	39
Passengers in the Cargo Box .....	21
Payload Warning .....	13
Periodic Maintenance Chart .....	113
Polaris Products .....	195
POLARIS Variable Transmission (PVT) System .....	157
Polishing the Vehicle .....	183
Pre-Ride Inspection .....	82
Programmable Service Interval .....	63
Proper Use Warning .....	12
Protective Apparel .....	19
PVT Drying .....	160

## R

Radiator Coolant Level / Changing Coolant .....	155
Radiators and Cooling Fan .....	154
Radio Compliance Statements .....	45
Refueling .....	25
Registration .....	205
Ride Command Buttons .....	48
Driveline Mode .....	50
Gauge Screens .....	51
Gauge View Mode .....	52
Icon Bar .....	52
Overview .....	47
Settings .....	51
Rider Information Center .....	58
Riders Warning .....	12
Rollover Protective Structure (ROPS).....	35

## S

Sachs® Shocks (if equipped) .....	167
Safe Operation Practices .....	83
Safe Riding Gear .....	10
Safety Labels and Locations .....	12
Safety Symbols .....	4
Safety Training .....	9
Safety Warnings .....	17
Safety, Winch Maintenance.....	110
Seat Belt Height Adjuster .....	42
Seat Belt Inspection .....	41
Seat Belt Warning .....	13
Seat Belts .....	18, 40
Seats .....	33
Service Access Panels .....	38
Service Intervals Maintenance .....	114
Severe Use Definition .....	113
Shock Loading the Winch .....	109
Signal Words .....	4
Skidding or Sliding .....	24
Spark Arrester .....	162
Spark Plug Condition.....	151
Spark Plug Gap / Torque .....	150
Spark Plug Removal and Replacement .....	150
Stalling While Climbing a Hill.....	23
Starting the Engine .....	84
Steering Wheel .....	33
Steering Wheel Inspection.....	178
Stopping the Engine.....	85
Storage Tips.....	183
Switches.....	30
Mode Button.....	56

## T

Tachometer .....	56
Taillight / Brake Light / Turn Signal Lamp Replacement .....	175
Tires .....	172
Towing a RZR .....	99
Towing Loads .....	99
Trail 900 Specifications .....	189
Trail Etiquette .....	86
Trail S 900 Specifications .....	192

---

Trailer Receiver Hitch Bracket .....	36
Transmission (Main Gearcase) ...	145
Transporting the Vehicle.....	187
Turning Improperly.....	22

## U

U.S.A. EPA Emissions Limited Warranty .....	210
Unauthorized Use of the Vehicle ...	26
Update Maps .....	54
Update Software .....	53
Using Alcohol or Drugs .....	18

## V

Vehicle Break-in Period.....	81
Vehicle Identification Numbers .....	8
Vehicle Immersion .....	177
Vehicle-to-Vehicle Communication (V2V).....	47

## W

Walker Evans Shock Compression Adjustment.....	171
Walker Evans Shocks.....	170
Warning Symbols .....	4
Warranty Coverage and Exclusions.....	206
Washing the Vehicle.....	182
Welcome Page .....	3
Wheel Installation .....	174
Wheel Removal.....	174
Winch Winch Operation .....	103
Winch Safety Precautions .....	101
Winch Cable Care .....	108
Winch Maintenance and Service Safety .....	110
Winch Shock Loading.....	109





For your nearest Polaris dealer,  
call 1-800-POLARIS (765-2747)  
or visit [www.polaris.com](http://www.polaris.com)

Polaris Industries Inc.  
2100 Highway 55  
Medina, MN 55340



Part No. 9931539 Rev 01  
Printed in USA